



NW-C1218

PROJECT MANUAL

FOR

NEW FULL SERVICE PARK – PHASE 2

AT

NISQUALLY STATE PARK

IN

PIERCE COUNTY

BID OPENING: 1:00 P.M., THURSDAY, MAY 16, 2024

**WASHINGTON STATE PARKS & RECREATION COMMISSION
1111 ISRAEL ROAD SW
TUMWATER, WA 98501-6512
POST OFFICE BOX 42650
OLYMPIA, WASHINGTON 98504-2650**



PROJECT MANUAL
FOR
NEW FULL SERVICE PARK – PHASE 2
AT
NISQUALLY STATE PARK
IN
PIERCE COUNTY

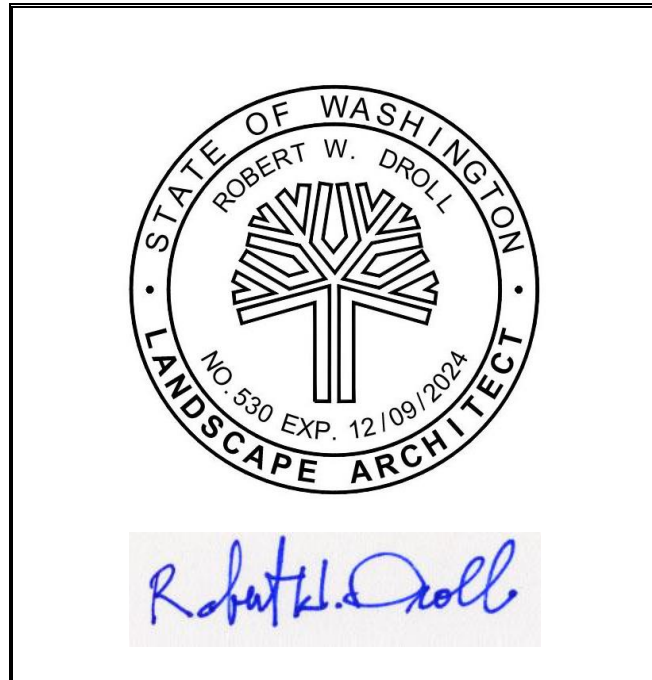

Approved for Construction *Heather Saunders*
Heather Saunders, Director of Parks Development

WASHINGTON STATE PARKS AND RECREATION COMMISSION
1111 ISRAEL ROAD SW
TUMWATER, WASHINGTON 98501-6512
P.O. BOX 42650
OLYMPIA, WASHINGTON 98504-2650

Diana Dupuis,
Director



STATE OF WASHINGTON
WASHINGTON STATE PARKS AND RECREATION COMMISSION

1111 Israel Road SW • PO Box 42650 • Olympia, WA 98504-2650 • (360) 902-8500
Internet Address: <http://www.parks.wa.gov>

April 10, 2024

Re: **Letter of Advertisement – Nisqually State Park – New Full Service Park
Phase 2 – NW-C1218**

To whom it may concern:

Please publish the following legal advertisement under your "Advertisement for Bid" section for two (2) consecutive days beginning on **Thursday, April 11, 2024, or at your earliest possible convenience**. An Affidavit of Publication will be required by this office. A voucher form is enclosed for your convenience in billing.

ADVERTISEMENT FOR BID

Sealed proposals will be received for the following project:

Nisqually State Park – New Full Service Park Phase 2

PROJECT DESCRIPTION:	This project includes a new Administration Building, new Staff Residence, and Roadway Improvements to the Nisqually River and Ohop Creek. Work includes, but is not limited to, site preparation, erosion control, excavation, utility improvements, construction of buildings and structures, aggregates, cast-in-place concrete, asphalt paving, catch basins and subsurface drainage, topsoil, restoration plantings and miscellaneous site improvements.
PROJECT LOCATION:	The project is located in Pierce County at the crossroads of SR7 and Mashel Prairie Road E, approximately 1-mile south along Mashel Prairie Road E on the west.
ESTIMATED BID RANGE:	\$ 8,770,000.00 - \$ 10,330,000.00
BID OPENING TIME:	1:00 PM on Thursday, May 16, 2024
PREBID WALKTHROUGH:	10:00 AM Thursday, May 02, 2024. Meet at Nisqually State Park Maintenance Building. From SR 7, turn down Mashel Prairie Road. Drive 1 mile down the road and the Maintenance Building will be on your right.

PLANS, SPECIFICATIONS, ADDENDA, AND PLAN HOLDERS LIST: Are available on-line through Builders Exchange of Washington, Inc. at <http://www.bxwa.com>. Click on: "bxwa.com"; "Posted Projects"; "Public Works", "Washington State Parks & Recreation", and "**DATE**". (Note: Bidders are encouraged to "Register as a Bidder", in order to receive automatic email notification of future addenda and to be placed on the "Bidders List". This service is provided free of charge to Prime Bidders, Subcontractors, and Vendors bidding this project.)

"PLANS MAY ALSO BE VIEWED THROUGH: Builders Exchange, Everett WA; Associated Builders And Contractors, Spokane WA; Tri City Construction Council, Kennewick WA; Daily Journal of Commerce, Seattle WA; Weekly Construction Reporter, Bellingham WA; Daily Journal Of Commerce Plan Center, Portland OR; Southwest Washington Contractors Association, Vancouver WA; Lower Columbia Contractor Plan Center, Longview WA.

Alternatively, bidders have the option to access Bid Documents, including Specifications and Drawings, at www.parks.wa.gov/contracts by clicking on the Construction Projects link for reference purposes. However, the official channel for notifications is through the Builders Exchange of Washington.

Technical questions regarding this project shall be directed to: Bob Droll, PLA, ASLA, *Owner's Representative at telephone: (360-456-3813), email: bob@rwdroll.com,*

Bid Results will be published on the State Parks Builders Exchange of Washington webroom and in the Construction Projects section at www.parks.wa.gov/contracts after the bid opening. This practice ensures that those involved and interested can readily view bid outcomes, enhancing transparency and efficiency in the bidding process.

The State of Washington prevailing wage rates are applicable for this public works project. Bidders are responsible to verify and use the most recent prevailing wage rates. The "Effective Date" for this project is the bid submittal time and date above.

Bidder Responsibility will be evaluated for this project. In determining bidder responsibility, the Owner shall consider an overall accounting of the criteria set forth in Division 00 – Instructions To Bidders. Please direct questions regarding this subject to the office of the Project Engineer.

Mandatory 15% apprentice labor hours of the total labor hours are a requirement of this construction contract. Voluntary workforce diversity goals for this apprentice participation are identified in the Instructions to Bidders. Bidders may contact the Department of Labor & Industries, Apprenticeship Section, to obtain information on available apprenticeship programs.

Per RCW 39.30.060, when the base bid combined with any alternates totals one million dollars or more, the Bidder must list the Subcontractors they intend to use for structural

steel, rebar installation, heating, ventilation, and air conditioning (HVAC), plumbing, and electrical work on the Subcontractor Utilization List form for this project.

The successful Bidder is required to complete their vendor registration in Access Equity, a secure B2GNow online vendor management system. Prime Contractors already registered with B2GNow for any public entity must ensure their information is up to date. The system can be accessed either directly at <https://omwbe.diversitycompliance.com/> or via the Office of Minority and Women's Business Enterprises (OMWBE) website at <https://omwbe.wa.gov/>.

For this project, voluntary diversity goals have been set: 10% for Minority Business Enterprises (MBE), 6% for Women's Business Enterprises (WBE), 5% for Washington Small Businesses, and 5% for Veteran-owned businesses. While meeting these goals is not mandatory, it is strongly encouraged to promote diversity in business participation.

Bidders may contact the Office of Minority and Women's Business Enterprise (OMWBE) at <http://omwbe.wa.gov/> to obtain information on certified firms. Bidders may also utilize Washington Small Businesses registered in WEBS at <https://pr-webs-vendor.des.wa.gov/> and Veteran-owned Businesses at <https://www.dva.wa.gov/veterans-their-families/veteran-ownedbusinesses/vob-search>.

Washington State Parks reserves the right to accept or reject any or all proposals and to waive informalities.

Sincerely,



Brett Taylor, Contracts Specialist
Contracts and Grants Program

BAT

cc: Stephanie Semek, Region Manager
Kyle Murphy, Capital Program Manager
Brian Yearout, Project Representative
Park Manager
OWMBE

**NISQUALLY STATE PARK
NEW FULL SERVICE PARK – PHASE 2**

"ADVERTISEMENT FOR BID" LETTERS

INVITATION TO BID	3 pages
INSTRUCTIONS TO BIDDERS	14 pages
SUPPLEMENTAL BIDDER CRITERIA.....	10 pages
SUMMARY OF PAY ITEMS AND QUANTITIES	3 pages
BID PROPOSAL FORM.....	4 pages
GENERAL CONDITIONS	41 pages
PREVAILING WAGE STATEMENT	1 page

AVAILABLE INFORMATION

Appendix A - Geotechnical Report.....	190 pages
Appendix B - Earthwork Calculations	9 pages
Appendix C - Diamond Pier Foundation Installation Manual	23 pages
Appendix D – Lead Assessment of Borrow Pit.....	111 pages

DIVISION 1 - GENERAL REQUIREMENTS

Section 010000 – General Requirements.....	5 pages
Section 010099 – Surveying	2 pages
Section 012300 – Alternate Bid Items	2 pages
Section 013000 – Administrative Procedures.....	3 pages
Section 013300 – Submittal Procedures	3 pages
Section 013500 – Project Meetings	3 pages
Section 013501 – Inadvertent Discoveries Of Cultural Resources And Human Skeletal Remains.....	5 pages
Section 013600 – Digital File Request Form.....	1 page
Section 014000 – Quality Requirements	7 pages
Section 014100 – Regulatory Requirements.....	2 pages
Section 014200 – References.....	3 pages
Section 014300 – Inspections and Tests	2 pages
Section 015000 – Temporary Facilities and Controls.....	7 pages
Section 015100 – Field Engineering.....	1 page
Section 015526 – Traffic Control	2 pages
Section 015639 – Temporary Tree and Plant Protection	7 pages
Section 015713 – Temporary Erosion and Sedimentation Control	7 pages
Section 016000 – Product Requirements	4 pages
Section 017329 – Cutting and Patching.....	4 pages
Section 017419 – Construction Waste Management and Disposal	2 pages
Section 017700 – Closeout Procedures.....	3 pages
Section 017839 – Project As-Built Documents	2 pages

**NISQUALLY STATE PARK
NEW FULL SERVICE PARK – PHASE 2**

DIVISION 3 – CONCRETE

Section 031000 – Concrete Forming and Accessories.....	6 pages
Section 032000 – Concrete Reinforcing	5 pages
Section 033000 – Cast-in-Place Concrete.....	36 pages
Section 033010 – Cement Concrete Paving	9 pages
Section 033020 – LithoMosaic	7 pages
Section 033543 – Polished Concrete Finishing	9 pages
Section 033900 – Concrete Curing and Sealing	2 pages

DIVISION 4 – MASONRY

Section 042613 – Masonry Veneer.....	15 pages
Section 043000 – Gate Plinths	11 pages

DIVISION 5 – METALS

Section 051200 – Structural Steel Framing	11 pages
Section 053100 – Steel Decking	3 pages
Section 055000 – Metal Fabrications	9 pages
Section 055200 – Pipe Handrail	4 pages

DIVISION 6 – WOOD PLASTICS AND COMPOSITES

Section 060573 – Wood Treatment	3 pages
Section 061000 – Rough Carpentry	13 pages
Section 061316 – Pole Construction.....	5 pages
Section 061600 – Sheathing.....	6 pages
Section 061753 – Shop-Fabricated Wood Trusses	8 pages
Section 061800 – Glue-Laminated Construction.....	5 pages
Section 062013 – Exterior Finish Carpentry.....	5 pages
Section 062023 – Interior Finish Carpentry.....	4 pages
Section 064100 – Architectural Wood Casework.....	14 pages
Section 064800 – Wood Frames	7 pages
Section 066400 – Plastic Paneling.....	3 pages
Section 067413 – Ecograte	5 pages

DIVISION 7 – THERMAL AND MOISTURE PROTECTION

Section 071113 – Bituminous Dampproofing	3 pages
Section 072100 – Thermal Insulation	9 pages
Section 072715 – Nonbituminous Self-Adhering Sheet Air Barriers.....	7 pages
Section 073013 – Roof Underlayments	4 pages
Section 074113.16 – Standing-Seam Metal Roof Panels.....	13 pages
Section 074293 – Soffit Panels	5 pages
Section 074646 – Fiber-Cement Panel Siding	8 pages
Section 076200 – Sheet Metal Flashing and Trim.....	14 pages
Section 076500 – Flexible Flashing.....	4 pages
Section 079200 – Joint Sealants	14 pages
Section 079219 – Acoustical Joint Sealants	4 pages

**NISQUALLY STATE PARK
NEW FULL SERVICE PARK – PHASE 2**

DIVISION 8 – OPENINGS

Section 081113 – Hollow Metal Doors & Frames.....	10 pages
Section 081416 – Flush Wood Doors	8 pages
Section 083613 – Sectional Doors.....	9 pages
Section 084213 – Aluminum-Framed Entrances.....	11 pages
Section 084313 – Aluminum-Framed Storefronts.....	12 pages
Section 085313 – Vinyl Windows	7 pages
Section 087100 – Door Hardware.....	20 pages
Section 088000 – Glazing.....	12 pages

DIVISION 9 – FINISHES

Section 092900 – Gypsum Board	8 pages
Section 093013 – Ceramic Tiling	7 pages
Section 095100 – Acoustical Ceilings	9 pages
Section 095426.13 – Surface Mounted Wood Ceilings.....	5 pages
Section 096513 – Resilient Base and Accessories.....	4 pages
Section 096516 – Resilient Sheet Flooring.....	6 pages
Section 096813 – Tile Carpeting	6 pages
Section 097413 – Wood Wall Coverings.....	5 pages
Section 098100 – Acoustical Insulation.....	4 pages
Section 098431 – Sound-Absorbing Wall and Ceiling Units	7 pages
Section 099000 – Painting and Coating.....	9 pages
Section 099300 – Staining and Transparent Finishing	5 pages
Section 099600 – High-Performance Coatings.....	7 pages
Section 099623 – Graffiti-Resistant Coatings	6 pages

DIVISION 10 – SPECIALTIES

Section 101100 – Visual Display Units.....	7 pages
Section 101401 – Regulatory Signage.....	5 pages
Section 101423 – Panel Signage.....	6 pages
Section 101423.16 – Room-Identification Panel Signage	6 pages
Section 102613 – Corner Guards.....	4 pages
Section 102813 – Toilet and Bath Accessories.....	6 pages
Section 103500 – Flagpole.....	4 pages
Section 104413 – Fire Protection Cabinets.....	5 pages
Section 104416 – Fire Extinguishers	4 pages
Section 105123 – Plastic-Laminate-Clad Lockers.....	7 pages

DIVISION 11 – EQUIPMENT

Section 113013 – Residential Appliances.....	10 pages
Section 115233 – Display Monitor Mounts.....	2 pages
Section 118129 – Facility Fall Protection.....	9 pages

DIVISION 12 – FURNISHINGS

Section 121200 – Wall Decorations.....	8 pages
Section 122113 – Horizontal Louver Blinds.....	5 pages

**NISQUALLY STATE PARK
NEW FULL SERVICE PARK – PHASE 2**

Section 122413 – Roller Window Shades..... 7 pages
Section 123623.13 Plastic-Laminate-Clad Countertops 7 pages

DIVISION 13 – SPECIAL CONSTRUCTION

Section 133470 – Prefabricated Restroom..... 11 pages
Section 133700 – Boardwalk 9 pages
Section 136000 – Kiosks 6 pages
Section 137000 – Diamond Pier Foundation 3 pages
Section 138000 – Horse Mounting Block..... 4 pages

DIVISION 21 – FIRE SUPPRESSION

Section 210500 – General Fire Suppression Requirements..... 11 pages
Section 211000 – Fire Sprinkler System..... 7 pages

DIVISION 22 – PLUMBING

Section 220500 – General Plumbing Requirements 11 pages
Section 220510 – Excavation & Backfill..... 6 pages
Section 220519 – Piping Specialties..... 2 pages
Section 220520 – Pipe & Pipe Fittings 4 pages
Section 220529 – Piping Hangers & Support 4 pages
Section 220530 – Pipe Sleeves & Seals..... 2 pages
Section 220548 – Piping Vibration & Seismic Control..... 2 pages
Section 220700 – Piping Insulation 5 pages
Section 221100 – Domestic Water Piping System 6 pages
Section 221123 – Pumps..... 2 pages
Section 221300 – Soil Waste & Vent Piping..... 5 pages
Section 221350 – Onsite Septic System 3 pages
Section 224000 – Plumbing Fixtures & Trim 10 pages
Section 224010 – Pumphouse Plumbing 6 pages

DIVISION 23 – HEATING VENTILATING AND AIR CONDITIONING (HVAC)

Section 230500 – General HVAC Requirements 10 pages
Section 230529 – HVAC Hangers & Supports..... 4 pages
Section 230548 – HVAC Vibration & Seismic Control 2 pages
Section 230593 – Air & Hydronic Balancing..... 6 pages
Section 230700 – HVAC Insulation 4 pages
Section 230900 – HVAC Controls 6 pages
Section 233100 – Ductwork..... 4 pages
Section 233300 – Air Duct Accessories 2 pages
Section 233400 – Fans..... 3 pages
Section 233700 – Air Outlets & Inlets 4 pages
Section 237200 – Heat Recovery Units 4 pages
Section 238100 – Air Conditioning Equipment..... 4 pages
Section 238300 – Electric Space Heating Equipment..... 3 pages

**NISQUALLY STATE PARK
NEW FULL SERVICE PARK – PHASE 2**

DIVISION 26 – ELECTRICAL

Section 260126 – Maintenance Testing for Electrical Systems.....	3 pages
Section 260500 – Common Work Results for Electrical Systems.....	16 pages
Section 260519 – Low Voltage Electrical Power Conductors and Cables	5 pages
Section 260526 – Grounding and Bonding for Electrical Systems.....	3 pages
Section 260533 – Raceway and Boxes for Electrical Systems	8 pages
Section 262413 – Switchboards.....	4 pages
Section 262416 – Panelboards	3 pages
Section 265000 – Lighting.....	8 pages

DIVISION 27 – COMMUNICATIONS

Section 271000 – Telecommunications Cabling	19 pages
---	----------

DIVISION 28 – ELECTRONIC SAFETY AND SECURITY

Section 282300 – IP Security Video Alarm.....	16 pages
Section 283100 – Fire Detection and Alarm.....	9 pages

DIVISION 31 – EARTHWORK

Section 311100 – Clearing and Grubbing.....	5 pages
Section 312000 – Earth Moving	11 pages
Section 312100 – Borrow Pit.....	3 pages
Section 316216 – Steel Piles.....	2 pages

DIVISION 32 – EXTERIOR IMPROVEMENTS

Section 321216 – Asphalt Paving	4 pages
Section 321500 – Crushed Rock Surfacing	3 pages
Section 321600 – Curbs and Gutters	3 pages
Section 321713 – Wheel Stops	3 pages
Section 321723 – Pavement Markings	3 pages
Section 321726 – Detectible Warning Surfacing.....	4 pages
Section 323100 – Landscape Logs	2 pages
Section 323113 – Chain Link Fencing.....	5 pages
Section 323116 – Security Cantilevered Slide Gate	8 pages
Section 323119 – Privacy Fence.....	4 pages
Section 323123 – Post and Rail Fence.....	4 pages
Section 323253 – Landscape Boulders	3 pages
Section 323300 – Site Furnishings	5 pages
Section 323303 – Keypad Island	3 pages
Section 323913 – Bollards.....	2 pages
Section 329113 – Mulch & Wood Chips.....	2 pages
Section 329119 – Topsoil Placement & Grading.....	5 pages
Section 329200 – Seed Mix	11 pages
Section 329300 – Plants.....	9 pages

**NISQUALLY STATE PARK
NEW FULL SERVICE PARK – PHASE 2**

DIVISION 33 – UTILITIES

Section 331300 – Water Distribution.....	5 pages
Section 333300 – Sanitary Sewers.....	2 pages
Section 334210 – Trench Drain	3 pages
Section 334600 – Stormwater Utilities	5 pages

DIVISION 46 – WATER AND WASTEWATER EQUIPMENT

Section 462010 – Water Treatment Equipment.....	5 pages
---	---------

END OF SECTION

**NISQUALLY STATE PARK
NEW FULL SERVICE PARK – PHASE 2**

INVITATION TO BID

1.1 SPECIAL NOTICE(S)

- A. Project work included in this bid will overlap and occur simultaneously with separately bid, adjacent, projects onsite. The Contractor shall schedule work to accommodate others' work onsite.
- B. Bidders are reminded that workers who work on construction, alteration, repair, improvement, or maintenance of park ranger residences are covered by the residential scopes for work on or in the residence itself only. Residential prevailing wage rates are not applicable to sidewalks, driveways, patios, detached garages, other outbuildings, and any other work not in or on the residence itself. The bidder must use commercial prevailing wage rates for work not on or in the residence itself.

1.2 DESCRIPTION OF WORK

- A. This project includes a new Administration Building, new Staff Residence, and Roadway Improvements to the Nisqually River and Ohop Creek. Work includes, but is not limited to, site preparation, erosion control, excavation, utility improvements, construction of buildings and structures, aggregates, cast-in-place concrete, asphalt paving, catch basins and subsurface drainage, topsoil, restoration plantings and miscellaneous site improvements.

1.3 LOCATION OF PROJECT

- A. The project is located at the crossroads of SR7 and Mashel Prairie Road E, approximately 1-mile south along Mashel Prairie RD E on the west. The addresses associated with the project include:

Administration Building: 44280 Mashel Prairie RD E Eatonville, WA 98328

Staff Residence: 44276 & 44278 Mashel Prairie RD E Eatonville, WA 98328

1.4 TECHNICAL QUESTIONS

- A. Direct project questions to:

Bob Droll, PLA, ASLA, Owner's Representative at:
Robert W. Droll, Landscape Architect, PS
4405 7th Avenue SE
Lacey, WA 98503
Phone: (360) 456-3813,
e-mail: bob@rwdroll.com

**NISQUALLY STATE PARK
NEW FULL SERVICE PARK – PHASE 2**

1.5 PRE-BID PROJECT SITE TOUR

DATE:	Thursday, May 2 nd , 2024
TIME:	10:00 AM
LOCATION:	Nisqually State Park – Maintenance Building. From SR 7, turn down Mashel Prairie Road. Drive 1 mile down the road. The Maintenance Building will be on your right.

1.6 BID OPENING

- A. Bid responses will only be accepted electronically via email/email attachment BidBox@parks.wa.gov. See Section 7.1 of the Instructions to Bidders for expanded details. Subject line shall read, NW-C1218 [YOUR COMPANY NAME], Bids are due at 1:00 p.m., Thursday, May 16, 2024.
- B. Bid result notification is made by e-mail within two (2) days of the bids due date. Bid results can be obtained on the State Parks webpage at www.parks.wa.gov/contracts or through Builders Exchange of Washington at www.bxwa.com
- C. The Commission reserves the right to accept or reject all bids and to waive informalities. No bidder may withdraw their bid after the bid deadline, or before award of contract, unless award is delayed over thirty (30) days.

1.7 COVID 19

- A. COVID-19 Refer to the Department of Labor & Industries website for requirements regarding any safety plans needed. [Novel Coronavirus Outbreak \(COVID-19\) Resources \(wa.gov\)](http://www.wa.gov/Novel-Coronavirus-Outbreak-(COVID-19)-Resources)

1.8 FOR INFORMATION ON:

- A. Reciprocal Preference, see Instructions to Bidders 2.1 Reciprocal Preference for Resident Contractors.
- B. Apprenticeship Requirements, For projects estimated at or over \$1,000,000, Apprenticeship Participation, Mandatory 15 percent apprentice labor, see Instructions to Bidders 4.1B Apprenticeship Participation.
- C. MWBE goals, see Instructions To Bidders 3.1 Minority And Women's Business Enterprise (MWBE) Utilization
- D. Modification of Bid, see Instructions to Bidders 8.1 Modification of Bid.
- E. Bid Security, see Instructions to Bidders 11.1 Bid Bond. No particular bid bond form is required.

**NISQUALLY STATE PARK
NEW FULL SERVICE PARK – PHASE 2**

1.9 ACCESSIBILITY

- A. Sites may not be fully accessible to people with disabilities. Please contact the Project Representative at least five (5) days prior to scheduled pre-bid tour if special accommodations are required for your attendance.

END OF SECTION

**WASHINGTON STATE PARK AND RECREATION COMMISSION
PUBLIC WORKS PROJECT**

1.1 BIDDER DEFINED

- A. A "*Bidder*" is an entity or person who submits a bid proposal for the work described in the contract documents.
- B. The Bidder must be registered by the Washington State Department of Labor and Industries in accordance with RCW 18.27.020. Insert the contractor registration number, expiration date, Uniform Business Identifier (UBI) number, and federal tax identification number on the Bid Proposal Form in the applicable spaces.

2.1 RECIPROCAL PREFERENCE FOR RESIDENT CONTRACTORS

- A. In accordance with RCW 39.04.380 the State of Washington is enforcing a Reciprocal Preference for Resident Contractors. Any public works bid received from a nonresident contractor from a state that provides an in-state percentage bidding preference, a comparable percentage disadvantage must be applied to the bid of that nonresident contractor.

A nonresident contractor from a state that provides a percentage bid preference means a contractor that:

- a) is from a state that provides a percentage bid preference to its resident contractors bidding on public works contracts.
- b) at the time of bidding on a public works project, does not have a physical office located in Washington.

The state of residence for a nonresident contractor is the state in which the contractor was incorporated or, if not a corporation, the state where the contractor's business entity was formed, and for an individual, the individual's state of residence.

All nonresident contractors will be evaluated for out of state bidder preference. If the state of the nonresident contractor provides an in-state contractor preference, a comparable percentage disadvantage will be applied to their bid prior to contract award.

This section does not apply to public works procured pursuant to RCW 39.04.155, 39.04.280, or any other procurement exempt from competitive bidding.

- B. A Comparable Percentage Disadvantage (CPD) will be applied to the bid of that nonresident contractor. The CPD is the in-state contractor percent advantage provided by the contractor's home state. For the purpose of determining the successful bidder, multiply the Nonresident Contractor bid amount by the CPD. The "bid amount" is be the total of the base bid and all accepted alternate bid items. The CPD is added to the Nonresident Contractor bid amount which equates to the Nonresident Disadvantage Total. The Nonresident Disadvantage Total is compared to the Washington contractor bid amounts. The bidder with the lowest total is the successful bidder.

See example below.

EXAMPLE: Alaska Nonresident Contractor Bid Amount \$100,000
Multiplied by the Alaska CPD x 0.05
Alaska CPD Total \$ 5,000
Alaska Nonresident Contractor Bid Amount \$100,000
Alaska CPD Total \$ 5,000
Nonresident Disadvantage Total \$105,000*

**WASHINGTON STATE PARK AND RECREATION COMMISSION
PUBLIC WORKS PROJECT**

* Note – If the Nonresident Disadvantage Total is lower than all other Washington contractor bid amounts, the Alaska Nonresident Contractor is the successful bidder and will be awarded a contract for the bid amount of \$100,000.

If the Nonresident Disadvantage Total is higher than a Washington contractor bid amount, the successful Washington bidder will be awarded a contract for the bid amount.

3.1 MINORITY AND WOMEN'S BUSINESS ENTERPRISE (MWBE) UTILIZATION

In accordance with the legislative findings and policies set forth in Chapter 39.19 RCW, the State of Washington encourages participation in contracts by MWBE firms certified by the Office of Minority and Women's Business Enterprises (OMWBE). Participation may be either on a direct basis in response to this solicitation/invitation or as a subcontractor to a Bidder. However, unless required by federal statutes, regulations, grants, or contract terms referenced in the contract documents, no preference will be included in the evaluation of bids, no minimum level of MWBE participation is required as a condition for receiving an award, and bids will not be rejected or considered non-responsive on that basis. Any affirmative action requirements set forth in federal regulations or statutes included or referenced in the contract documents will apply.

3.2 VETERAN-OWNED BUSINESS AND SMALL, MINI, AND MICRO BUSINESS UTILIZATION

The State of Washington encourages participation in all of its contracts by Veteran-owned businesses (defined in RCW 43.60A.010) and located at <http://www.dva.wa.gov/program/certified-veteran-and-servicemember-owned-businesses> and Small, Mini and Micro businesses (defined in RCW 39.26.010) which have registered in WEBS at <https://pr-webs-vendor.des.wa.gov/>.

4.1 REQUIREMENTS FOR PROJECTS ESTIMATED AT \$1,000,000 OR MORE

A. Pursuant to [RCW 39.30.060](#), if the base bid combined with the sum of the alternates exceeds one million dollars (\$1,000,000.00) or more for the construction, alteration, or repair of any public building or public work of the state shall require each Bidder to submit as part of the bid the names of subcontractors with whom the Bidder, if awarded the contract, will subcontract for performance of the work of heating, ventilation and air conditioning, plumbing, and electrical, structural steel installation, rebar installation or to name itself for the work. The Bidder shall not list more than one subcontractor for each category of work identified, unless subcontractors vary with bid alternates, in which case the Bidder must indicate which subcontractor will be used for which alternate. **Failure of the Bidder to submit as part of the bid, the names of such subcontractors, or to name itself to perform such work, or the naming of two or more subcontractors to perform the same work, shall render the bid as non-responsive and therefore void.**

B. APPRENTICESHIP PARTICIPATION

In projects estimated to cost One Million Dollars or more, be aware that the following requirements will be part of the resulting contract.

In accordance with [RCW 39.04.320](#) (Apprenticeship Training Programs), for all public works estimated by the WSPRC Project Engineer to cost **one million dollars or more**, the state of Washington requires no less than **15% of the labor hours be performed by apprentices**. A contractor or subcontractor may not be required to exceed the 15% requirement. The bid advertisement and Bid Proposal Form shall establish a minimum required percentage of apprentice labor hours compared to the total labor hours.

**WASHINGTON STATE PARK AND RECREATION COMMISSION
PUBLIC WORKS PROJECT**

1. **Incentives** - The Contractor who meets or exceeds this utilization requirement on eligible contracts, will be awarded a monetary incentive described in the Apprentice Utilization Requirements section of the Bid Form.
 2. **Penalties** - The Contractor who fails to meet the utilization requirement and fails to demonstrate a Good Faith Effort, as outlined below, is subject to penalties described in the Apprentice Utilization Requirements section of the contract Bid Form. Contractor will receive an invoice payable to the Owner within 30 days.
 3. **Cost Value** - The expected cost value associated with meeting the goal is included in the Base Bid as described on the Bid Form.
 4. **Utilization Plan** - The Contractor shall provide an Apprentice Utilization Plan (Plan) demonstrating how and when they intend to achieve the Apprenticeship Utilization Requirement. The Plan shall have enough information to track the Contractor's progress in meeting the utilization requirement. The Contractor shall submit the Plan on the Apprentice Utilization Plan template within 10 business days of Notice to Proceed of the contract and prior to submitting the first invoice. The Contractor shall provide an updated Plan during the course of construction when there are significant changes to the Plan which may affect their ability to meet the requirement.
 - a) The Plan shall be uploaded to the Department of Labor & Industries' (L&I): ***Prevailing Wage Intents and Affidavit (PWIA) system on L&I's website.***
 - b) The Plan is not submitted for approval.
 - c) It is expected that the Contractor will actively seek out opportunities to meet the Apprentice Utilization Requirement during construction even if the Plan indicates a shortfall in meeting the requirement.
 - d) If the Plan indicates that the Contractor will not attain the Apprentice Utilization Requirement, then Contractor must submit "Good Faith Effort" (GFE) documentation with their Plan to L&I's PWIA system.
- C. APPRENTICESHIP - GOOD FAITH EFFORT (GFE)
1. **Good Faith Effort (GFE)** documentation shall describe in detail why the Contractor is not or was not able to attain the Apprentice Utilization Requirement.
 - a) Contractors may submit Good Faith Effort (GFE) documentation at any time during the construction.
 - b) All GFE documentation must be submitted no later than 30 days before substantial completion.
 - c) Good Faith Effort (GFE) documentation must be in signed letter format uploaded to the PWIA system and include:
 1. The contract number, title and the apprentice utilization requirements,
 2. The amount of apprentice labor hours the contract can or did attain along with the percentage of labor hours,
 3. Contractors may receive a GFE credit for graduated Apprentice hours through the end of the calendar year for all projects worked on as long as the Apprentice remains continuously employed with the same Contractor they were working for when they graduated. If an Apprentice graduates during employment on a project of significant duration, they may be counted towards a GFE credit for up to one year after their graduation or until the end of the project (whichever comes first). Determination of whether or not Contract requirements were met in good faith will be made by subtracting the hours from the journeyman total reported hours for the project and adding them to the apprentice hour total. If the new utilization percentage meets the Contract requirement, the Contractor will be reported as meeting the requirement in good faith,

**WASHINGTON STATE PARK AND RECREATION COMMISSION
PUBLIC WORKS PROJECT**

4. Anticipated or actual shortfall (in apprentice labor hours and percentage) and the reason(s) for not attaining the required apprentice labor hours,
5. Information from one or more of the following areas:
 - (a) Names of any State-Approved Apprentice Training Programs contacted with the name(s) of person(s) contacted and dates of contacts, and a copy of each response from the Training Program(s),
 - (b) Reference Contract Specifications or documents that affected the Contractor's ability to attain apprentice utilization,
 - (c) Discuss efforts the Contractor has taken to require Subcontractors to solicit and employ apprentices,
6. Backup documentation to the letter consisting of the following:
Letters, emails, phone logs including names dates and outcomes, posters, photos, payrolls, time cards, schedules, copies or references to other contract specifications or documents.

Additional Resource Information

- (a) For questions regarding how to complete the Apprentice Utilization Plan template or Good Faith Effort documentation, please contact the Project Manager listed in the Bid Advertisement.
- (b) Step-by-step instructions on how to access and navigate the L&I's PWIA system, including uploading required documents can be found on the L&I website.
- (c) Additional information about apprentice utilization on Public Works Project can be found on the L&I website.

5.1 EXAMINATION OF THE WORK SITE AND BIDDING DOCUMENTS

- A. Bidder acknowledges that it has taken steps necessary to ascertain the nature and location of the work, and that it has investigated and satisfied itself as to the general and local conditions which can affect the work or its cost, including but not limited to (1) conditions bearing upon transportation, disposal, handling, and storage of materials; (2) the availability of labor, water, electric power, and road; (3) uncertainties of weather, river stages, tides, or similar physical conditions at the site; (4) the conformation and conditions of the ground; and (5) the character of equipment and facilities needed preliminary to and during the work. The bidder also acknowledges that it has satisfied itself as to character, quality, and quantity of surface and subsurface materials or obstacles to be encountered insofar as this information is reasonably ascertainable from an inspection of the site, including exploratory work done by the Owner, as well as from the drawings and specifications made a part of this contract. Any failure of the Bidder to take the actions described and acknowledged in this paragraph will not relieve the Bidder from responsibility for estimating properly the difficulty and cost of successfully performing the work.
- B. No statement by any officer, agent, or employee of the Agency pertaining to the physical conditions of the site of the work will be binding on the Agency other than those statements issued in the contract documents.
- C. Bidders shall promptly notify the Agency of ambiguities, inconsistencies, or errors, if any, which they may discover upon examination of the Bidding Documents or of the site and local conditions.
- D. Interpretations and Clarifications

**WASHINGTON STATE PARK AND RECREATION COMMISSION
PUBLIC WORKS PROJECT**

- 1) Every request for interpretation or clarification should be submitted to the project representative as listed in the Invitation to Bid. If a Bidder does not have on-line capability, then submit in writing, addressed to the project representative at the address as listed in the Invitation to Bid. To be given consideration the request must be received seven (7) working days prior to the date fixed for the opening of the bids.
- 2) The Agency's responses, if there are any, which do not change the Scope of Work described in the contract documents may be mailed, delivered, faxed, or by other electronic means, to all planholders of record, at the respective address furnished for such purposes, prior to the date fixed for the receipt of bids. Such letters of clarification shall not be considered part of the contract documents and therefore need not be acknowledged by the Bidders as part of the Bid Form. The Agency will determine at its sole discretion whether or not any clarification or interpretation changes the Scope of Work and should be included in the Contract Documents.
- 3) Clarifications, interpretations, or supplemental instructions which do change the Scope of Work and or schedule described in the contract documents, will be issued only in the form of written ADDENDA.
- 4) Oral interpretations or clarifications will be without legal effect.

E. Substitutions

- 1) The product, equipment, materials, or methods described or noted within the Bidding Documents, whether currently available or not, are to establish a standard of quality, function, appearance and dimension. A proposed substitution shall have equal attributes in all respects.
- 2) No substitution will be considered unless a written request for approval is submitted by the Contractor, after Award, in accordance with the applicable provisions of Section 012500 of the specifications. If no Section 012500 is available, then see section 016000 Product Requirements, sub-section 1.5. Each such request shall describe the proposed substitution in its entirety including name of the material or equipment, drawings, catalog cuts, performance or test data and all other information required for an evaluation. The submittal shall also include a statement noting all changes required in adjoining, dependent or other interrelated work necessitated by the incorporation of the proposed substitute. The Bidder shall bear the burden of proof of merit of the proposed substitution. The Project Representative's decision of approval or disapproval of a proposed substitution shall be final.

6.1 BID PROPOSAL

- A. The Bidder shall submit its bid on the forms included with these instructions. All blank spaces in the Bid Proposal Form must be properly filled in. If the bid is made by a partnership or co-partnership, it must be so stated and it must be signed in the firm's name, followed by the written signature of the signing partner. If the bid is made by a corporation, it must be signed in the name of the corporation, followed by the written signature of the officer signing, and the printed or typewritten designation of their office within the corporation. The full and complete address of the Bidder must be typed or printed on the bid in the spaces provided. The bid must be a scan of the original bid, complete with an original signature (pen to paper).

**WASHINGTON STATE PARK AND RECREATION COMMISSION
PUBLIC WORKS PROJECT**

- B. Except as otherwise provided in these instructions, bid proposals that are incomplete, or that are conditioned in any way, or that contain erasures, alterations, or items not called for in the contract documents, or that do not conform to the call for bids, may be rejected as non-responsive at the discretion of the Agency unless the law requires that the omission be deemed non-responsive, in which case the bid will be rejected as non-responsive. Only the amounts and information asked for on the Bid Proposal Form and the plans and specifications furnished will be considered as the bid. Bid amounts include all taxes imposed by law, **except** for Washington Sales Tax unless noted otherwise.
- C. Each Bidder shall bid upon the work exactly as specified and as provided in the Bid Proposal Form. The Bidder shall bid upon all alternates if alternates are indicated on the Bid Proposal Form. When bidding on alternates for which there is no charge, the Bidder shall write the words "no charge" in the space provided on the Bid Proposal Form.
- D. Bidders shall acknowledge receipt of any ADDENDA to the solicitation for bids on the Bid form.

7.1 SUBMISSION OF BID

- A. Bid responses will only be accepted electronically via email/email attachment BidBox@parks.wa.gov.
- B. Marking of The Bid Response (Email Subject Line):

Subject line should include the bid's identification number, "Bid" and Company name.

- Example email subject line: NW-C9999 Bid John Smith Construction LLC
- Example email subject line: EW-C9999 Bid Sunshine Construction Corp.

- C. Signature (what is acceptable):

The purpose of a signature is to ensure a manifestation of asset by the signer and to legally bind the signer to the documents submitted.

In 2020 Washington State enacted law allowing for alternatives to hardcopy original wet-ink signatures. While the Bidder cannot force any process upon the Agency, the Agency can mandate and accept alternatives to an original wet-ink signature.

The Agency will accept a picture of an original wet-ink signature, such as a PDF scan. .JPG, TIFF-Group 4 (or similar technology). These three (3) technologies are known to work. The Bidder's use of other technology is at the Bidder's risk and peril. Bids or bid formats that the Agency cannot open and view shall be deemed non-responsive.

For clarity: Print out the competition document, review it, include any other required document(s) (such as the Bid Bond if required), complete where necessary, sign where indicated with a pen onto the paper, when you believe your bid response is ready to be submitted to the Agency, scan it as a PDF file, check the PDF file to make sure all pages are legible, then attach the file to your business email and send it to BidBox@parks.wa.gov.

It is the Agency's expectation that the Bidder's bid response email will contain a PDF attachment with all of the required documents scanned as a PDF, including any required signatures.

**WASHINGTON STATE PARK AND RECREATION COMMISSION
PUBLIC WORKS PROJECT**

7.2 Bid Clock:

After the bid opening (due date deadline), Agency staff will review the bids. The email's date and timestamp that is visible on the email, from the Agency's perspective, shall serve as the bid clock and it is this information that will be used to determine if the bid was timely.

CAUTION: Submit your bid response early as a safeguard against any technological slow-down or delays and/or malfunctions. Bids received after the deadline for any reason, no matter the cause, regardless of responsibility, will be rejected. When and whatever time the email comes in, the Procurement Coordinator will reference the email's timestamp to determine responsiveness.

You are welcome to follow up with an email to contracts@parks.wa.gov and ask confirmation of receipt and the Procurement Coordinator can send a reply to the sender of the bid response. However, our ability to respond is not instantaneous, not guaranteed, and works best if there's at least three (3) business days of time to respond.

8.1 MODIFICATION OF BID

A. Modifying And Supplementing Prior To Bid Opening:

Modifying: Modifying refers to a bid that has already been submitted to the Agency. Modifying means altering information already contained in the Bidder's bid response that has already been submitted to the Agency.

Supplementing: Supplementing refers to a bid that has already been submitted to the Agency. Supplementing means adding to the bid response for materials, documents, or information not already in the Bidder's bid response.

HOW: Bidder may modify or supplement its bid prior to the bid due date by sending a replacement bid by email to: BidBox@parks.wa.gov. In the body of the email clearly explain that this bid response is replacing an earlier one. Follow the example subject line.

Example email subject line: SWR-SW-C9999 Replacement Bid ACME Construction Inc.

Do not send in a piece of a bid response asking the Agency to link it up with the earlier bid response. Send in a full and complete replacement.

9.1 WITHDRAWAL OF BID

A. Withdrawal refers to a bid that has already been submitted to the Agency. A bid response may be withdrawn by a Bidder before the Bid Opening (due date deadline) for the bid. The FAILURE TO WITHDRAW a bid prior to the bid due date deadline exposes the Bidder to the possibility that the Agency will make a demand against the Bidders bid bond.

B. HOW: Bidder may withdraw its bid prior to the bid due date by sending an email to: BidBox@parks.wa.gov. In the body of the email clearly explain that the earlier bid submission is being withdrawn. Follow the example subject line.

Example email subject line: SWR-SW-C9999 Withdraw Bid ACME Construction Inc.

**WASHINGTON STATE PARK AND RECREATION COMMISSION
PUBLIC WORKS PROJECT**

10.1 REJECTION OF BID

- A. The Agency reserves the right to reject any or all bids and to waive informalities in connection with the bids.

11.1 BID BOND

- A. When the total bid amount is \$35,000 or less, a bid bond is not required. When the sum of the base bid plus all additive bid alternates is \$35,000.00 or less, bid security is not required.
- B. When the sum of the base bid plus all additive alternates is greater than \$35,000.00, a bid guarantee in the amount of 5% of the base bid amount is required. Failure of the Bidder to provide bid guarantee when required shall render the bid non-responsive.
- C. Acceptable forms of bid guarantee are: A bid bond. A copy of the bid bond must be included along with your bid response to the Agency. See also, Section 7.1 SUBMISSION OF BIDS – SECTION A.
- D. Should the successful Bidder fail to enter into a contract and furnish a satisfactory performance bond within 15 days after receiving properly prepared contract forms from the Agency, the bid bond may be forfeited as liquidated damages for advertisements and administration of bid procedures.
- E. Bid bonds must be held for the three low bids for 30 days or until a contract is executed with the successful Bidder. All other bid bonds will be returned to the Bidders within 15 days of the bid opening.

12.1 BID EVALUATION AND AWARD OF CONTRACT

- A. Award of contract will be made by the Agency based upon any combination of the base bid and alternates that, in the Agency's sole discretion, is in the Agency's best interest considering price, schedule, and other factors. The numbering of the alternates in the bid proposal bears no relationship to the order in which the alternates may be selected by the Agency. Additionally, the Agency reserves the right to negotiate base bid prices (including changes to the contract plans and specifications) with the low responsive, responsible Bidder to bring the final contract amount within the funds available.

- B. BID TABULATION AND ANNOUNCEMENT OF APPARENT LOW BID:

DON'T CALL STATE PARKS TO OBTAIN BID RESULTS.

The Agency does not guarantee when the Bid results will be released to the public. The bid results are usually released within three business days of the bid opening and often the same day. Bid results can be obtained by accessing the Washington State Parks webpage at www.parks.wa.gov/contracts (see "Construction Projects- Public works bid results"). The Bid Tabulation results may also be released through Builders Exchange of Washington at www.bxwa.com. But, Bidders are cautioned that the Washington State Parks website is the official release point for the Bid Tabulation for this competition.

The bid tabulation will identify all bids received by the Agency. Bids that were not rejected and not withdrawn prior to the bid opening will be ranked by base bid price. The first three lowest base bids will reflect detailed pricing information. The remaining Bidders will reflect only the base bid pricing. Bids that were rejected for any reason will reflect **Non-Responsive** in the bid tabulation but may include its total pricing.

**WASHINGTON STATE PARK AND RECREATION COMMISSION
PUBLIC WORKS PROJECT**

Release of the Bid Tabulation information that a Firm was identified as the apparent low base bid simply means that at this point in time the Agency believes the subject bid was the lowest cost responsive bid, but designation as the apparent low responsive bid is not a guarantee of a contract with the Agency. The Agency reserves the right to consider Alternate Bid Items in any combination. The Agency reserves the right to reevaluate the bid and determine whether the bid was responsive and responsible and successful as first thought. The Bidder identified as the apparent low responsive bid is cautioned not to commit funds, resources, and effort prior to receiving an actual executed contract. The Bidder identified as the apparent low responsive bid that commit funds, resources, and effort prior to a contract do so at its own risk and peril.

BID TABULATION & PROTEST: Within two (2) business days following the day of the release of the Bid Tabulation/Announcement of the Apparent Low bid (on the Washington State Parks website), the Bidder may file a Protest (Protest procedures are outlined in Section 13.1).

- C. **REJECTION LETTER & PROTEST:** No matter the phase of the evaluation, if the Agency determines that the bid is not responsive or the Bidder is not responsible, the Agency will reject the bid/bidder, and send the bidder a Rejection Letter explaining why the bid/bidder was rejected. Within two (2) business days following the day of the release of the Rejection Letter, the Bidder may file a Protest, provided it meets one of the three (3) protest grounds (Protest procedures are outlined in Section 13.1). The Rejection Letter will be sent by email/email attachment to the email address provided by the Bidder in the Bidder's bid response.
- D. The intent of the Agency is to award a contract to the low responsive, responsible bidder by considering the following:

Responsible - A Bidder must meet the following mandatory responsibility criteria under RCW 39.04.350 (1) to be considered a responsible Bidder and qualified to be awarded a public works project. The Bidder must:

1. At the time of bid submittal, have a certificate of registration in compliance with Chapter 18.27 RCW;
2. Have a current state Unified Business Identifier (UBI) number;
3. If applicable, have industrial insurance coverage for the Bidder's employees working in Washington as required in Title 51 RCW; an employment security department number as required in Title 50 RCW; and a state excise tax registration number as required in Title 82 RCW;
4. Not be disqualified from bidding on any public works contract under RCW 39.06.010 or 39.12.065(3);
5. If bidding on a public works project subject to the apprenticeship utilization requirements in RCW 39.04.320, not have been found out of compliance by the Washington State Apprenticeship and Training Council for working apprentices out of ratio, without appropriate supervision, or outside their approved work processes as outlined in their standards of apprenticeship under Chapter 49.04 RCW for the one-year period immediately preceding the date of the bid solicitation; and
6. Public Works and Prevailing Wage Training/Exemption. Bidders shall have received training on the requirements related to public works and prevailing wage under this chapter and chapter 39.12 RCW. The bidder must designate a person or persons to be trained on these requirements. The training must be provided by the department of labor and industries or by a training provider whose curriculum is approved by the department. The

**WASHINGTON STATE PARK AND RECREATION COMMISSION
PUBLIC WORKS PROJECT**

department, in consultation with the prevailing wage advisory committee, must determine the length of the training. Bidders that have completed three or more public works projects and have had a valid business license in Washington for three or more years are exempt from this subsection. The department of labor and industries must keep records of entities that have satisfied the training requirement or are exempt and make the records available on its website. Responsible parties may rely on the records made available by the department regarding satisfaction of the training requirement or exemption. <https://lni.wa.gov/licensing-permits/public-works-projects/contractors-employers/contractor-training>

7. Within the three-year period immediately preceding the bid solicitation, not have been determined by a final binding citation and notice of assessment issued by the department of labor and industries or through a civil judgment entered by a court of limited or general jurisdiction to have willfully violated, as defined in RCW 49.48.082, any provision of Chapters 49.46, 49.48, or 49.52 RCW. By signing the Bid Proposal Form, the bidder verifies under penalty of perjury, pursuant to RCW 9A.72.085. that the bidder is in compliance with this subsection
8. Supplemental Responsibility Criteria: In addition to the mandatory Bidder responsibility, the Agency may adopt relevant supplemental criteria for determining Bidder responsibility applicable to a particular project which the Bidder must meet (RCW 39.04.350 (3)).
 - a. If applicable, the Agency shall consider an overall accounting of the attached supplemental criteria for determining Bidder responsibility "DIVISION 00 SUPPLEMENTAL RESPONSIBILITY CRITERIA".
 - b. At least seven (7) days prior to the bid submittal deadline, a potential Bidder may request that the Agency modify the supplemental responsibility criteria. The Agency will evaluate the information submitted by the potential Bidder and respond before the bid submittal deadline. If the evaluation results in a change of the criteria, the Agency will issue an ADDENDA to the bidding documents identifying the new criteria.
 - c. Upon the Agency's request, the apparent low Bidder must supply the requested responsibility information within two (2) business days of request by the Agency. Withholding information or failure to submit all the information requested within the time provided may render the bid non-responsive and the bid/Bidder may be rejected by Rejection Letter.

Responsive - A bid will be considered responsive if its electronic response meets the following requirements:

1. It is received at the proper time and place.
2. It meets the stated requirements of the Bid Proposal Form.
3. It meets the requirements as stated in section 6.1.A of the Instructions To Bidders.
4. It is submitted by a licensed/registered contractor within the state of Washington at the time of bid opening.
5. It is accompanied by a bid guarantee, if required.

If inconsistencies or errors are noted in the bid proposal prices, **prices shown in words have precedence over prices shown in figures.** The **unit and lump sum prices have precedence over their total amounts;** and the **total amounts have precedence over the total bid.**

**WASHINGTON STATE PARK AND RECREATION COMMISSION
PUBLIC WORKS PROJECT**

The apparent low Bidder, for purpose of award, is the responsive and responsible Bidder offering the low aggregate amount for the base bid plus selected additive or deductive bid alternates and meeting all other bid submittal requirements.

13.1 PROTEST PROCEDURES

A. GENERAL:

This protest process is a courtesy provided by the Agency and it is not governed by Washington's Administrative Procedures Act (APA), RCW 34.05, nor does it confer any additional rights above and beyond what the Bidder already enjoys as a taxpayer. The purpose of this process is to allow the Agency to correct evaluation process errors and problems before a contract is executed.

Only a Bidder may file a protest regarding this competition.

The Bidder must strictly adhere to the protest process as set forth herein, the failure of which may result in a summary determination that the protest is without merit without an opportunity to cure.

B. FORM AND CONTENT:

All protests must:

- Be in writing.
- The protest must state and clearly articulate the grounds for the protest with specific facts and complete statements of the action(s) being protested.
- A description of the relief or corrective action being requested should also be included.
- All protests shall be addressed to the Procurement Coordinator.

C. CONTENT LIMITATIONS:

The Agency does not currently mandate any page limitation. However, the protest must be clearly articulated, succinct, organized, logical, and professional.

The Agency will reject protests that:

- fail to state and clearly articulate at least one of the three GROUNDS;
- contain rants, attacks, and/or disparaging or abusive remarks;
- include multiple attachments or references (document dumping, document overload); or,
- appear to require the reader piece together voluminous amounts of material to decipher the argument being made.

D. SUBMISSION OF PROTEST:

- All protests must be submitted within two (2) business days following the day of the release of the Bid Tabulation/Announcement of the Apparent Low bid or after the formal Rejection Letter is sent. For purposes of timing the day of the release of the Bid Tabulation or the day of the Rejection Letter is sent to the Bidder shall not count.
- Bidders must send all protests to: contracts@parks.wa.gov. See also Subject Line.
- SUBJECT LINE: Must include the competition's Number Identifier and "PROTEST" in the subject line. Failure by the Bidder to include this information in the subject line may result in Bidder's protest not being timely recognized.

**WASHINGTON STATE PARK AND RECREATION COMMISSION
PUBLIC WORKS PROJECT**

E. GROUNDS WHICH MAY BE PROTESTED:

- Conflict of Interest on the part of Agency staff.
- Errors in computing the score.
- Non-compliance with procedures described in the procurement document.

Protests will be rejected as without merit if they do not clearly and convincingly meet one of the GROUNDS above and/or seems to address issues such as:

- An evaluator's professional judgment on the quality of a response, or
- The Agency's assessment of its own and/or other agencies' needs or requirements, or,
- Issues, concerns, objections, or requests for changes that were or could have been addressed prior to the bids due date deadline.

Protests that do not clearly and convincingly meet the requirements and standards described herein are without merit and may be rejected.

F. MANAGER ASSIGNMENT AND REVIEW:

Upon receipt of a protest that meets the requirements described herein, a protest review will be held by the Agency. The Agency will assign a Manager. The Manager is responsible for reviewing and investigating the Bidder's written protest and may meet with agency staff or the agency program that was involved in the competition. The Manager may consider the record and all reasonably available facts and will issue a protest determination in writing within fifteen (15) business days from receipt of the protest. If additional time is needed, the Manager will notify the protesting party of the need for additional time within 15 business days from receipt of the protest.

In the event a protest may affect the interest of another Bidder that submitted a response, the Agency may reach out to that Bidder, may provide an unedited copy of the protest to that Bidder, and may invite that Bidder to submit its views and any relevant information on the protest to the Manager.

G. PROTEST DETERMINATION AND FINDINGS AND DISSEMINATION:

The Manager's protest determination may:

- Find the protest lacking in merit and reject the protest;
- Find only technical or harmless errors in the Agency's acquisition process and determine the Agency to be in substantial compliance and reject the protest; OR
- Find merit in the protest and provide THE AGENCY options which may include:
 - Correcting the errors and re-evaluating all responses;
 - Canceling the competition and possibly for a new competition to take place; OR
 - Making other findings and determining other courses of action as appropriate.

If the Agency rejects the protest, the Agency will enter into a contract with the Apparent Successful Bidder no sooner than two business days after issuance of the protest determination by email to the protesting party at the email address indicated on the party's bid documents. For the purposes of timing, the date the protest determination is sent to the protesting party shall not count.

**WASHINGTON STATE PARK AND RECREATION COMMISSION
PUBLIC WORKS PROJECT**

Dissemination: The Agency will disseminate the decision to all interested Bidders via email/email attachment to the email address provided by the Bidder in the Bidder's bid response.

H. AGENCY DECISION IS FINAL:

The Manager's protest determination constitutes the agency's final decision regarding the protest. If the protesting party disagrees with the protest determination, the Bidder may seek judicial relief in the Washington Superior Court for Thurston County within 2 business days of the issuance of the protest determination.

I. STRICT COMPLIANCE

Strict compliance with these protest procedures is essential in furtherance of the public interest. Any aggrieved party that fails to comply strictly with these protest procedures is deemed, by such failure, to have waived and relinquished forever any right or claim with respect to alleged irregularities in connection with the solicitation or award of the Contract. No person or party may pursue any judicial or administrative proceedings challenging the solicitation or award of this Contract, without first exhausting the administrative procedures specified herein.

J. REPRESENTATION

An aggrieved party may participate personally or, if a corporation or other artificial person, by a duly authorized representative. Whether or not participating in person, an aggrieved party may be represented, at the party's own expense, by counsel.

K. COMPUTATION OF TIME

In computing any period of time prescribed by this procedure, the day of the act or event from which the designated period of time begins to run is not included. The last day of the period is included. The term "business day" does not include Sunday, Saturday, or Washington State recognized holiday.

L. ACKNOWLEDGEMENT

By submitting a bid in response to this solicitation, the Bidder acknowledges that it has reviewed and acquainted itself with the bid protest procedures herein and agrees to be bound by such procedures as a condition of submitting a bid.

14.1 EXECUTION OF CONTRACT

- A. The successful bidder will be required to execute the contract and furnish performance bond and insurance certificate satisfactory to the Agency within 15 days after receiving properly prepared contract documents from the Agency.

15.1 SUBCONTRACTOR PARTICIPATION MONITORING AND REPORTING

- A. Once a contract is awarded through the solicitation or proposal process, the awarded Prime Contractor is obligated to complete the vendor registration in Access Equity. Access Equity is a secure online vendor management system (B2GNow). Confidential information (Tax ID, etc.) will not be published. Prime Contractors that have previously registered with B2Gnow for any public entity, must verify the system has updated information. Contractors can access the system at <https://omwbe.diversitycompliance.com/> or through a direct link on the Office of Minority and Women's Business Enterprises (OMWBE) website at: <https://omwbe.wa.gov/>.

**WASHINGTON STATE PARK AND RECREATION COMMISSION
PUBLIC WORKS PROJECT**

- B. Each month during the contract, the Prime Contractor will report payments to ALL Subcontractors through the Access Equity system. This monthly reporting information includes total payment in dollars made to the Subcontractor, payment dates, and any additional information required to verify payment to Subcontractors. The Prime Contractor will enter this payment information into the Access Equity system, and the Subcontractors will verify this payment information in the system. Online training is available through the Access Equity/B2Gnow system. This requirement applies to both Prime Contractors and Subcontractors.

END OF INSTRUCTIONS TO BIDDERS

/ / / / /

NISQUALLY STATE PARK
NEW FULL SERVICE PARK Phase 2

SUPPLEMENTAL BIDDER RESPONSIBILITY CRITERIA
WITH INCLUSION PLAN AND APPRENTICESHIP REQUIREMENTS

Low Responsible Bidder

It is the intent of the Owner to award a contract to the lowest responsive and responsible Bidder. In determining the Bidder's responsibility, the Owner shall consider an overall accounting of the items listed below. Potential Bidders may request the Owner modify the Bidder responsibility criteria. The request must be in writing and submitted at least 7 days prior to the bid opening.

The apparent low bidder shall submit the required information within **two (2)** business days of receiving request from Owner. This request may be made in the form of a telephone call or email message. The required information shall be provided on the referenced forms bound herein. Electronic copies may be made available upon request. Failure to submit such information to the satisfaction of the Owner within the time provided may render the Bidder as not responsible.

1.1 REQUIRED INFORMATION/CRITERIA

- A. For the purposes of the Supplemental Bidder Responsibility evaluation process, the scope of this project generally involves, but is not limited to: site preparation, erosion control, excavation, utility improvements, construction of buildings and structures, aggregates, cast-in-place concrete, asphalt paving, catch basins and subsurface drainage, topsoil, restoration plantings and miscellaneous site improvements.
- B. Experience Of Contractor On Projects Of Similar Size And Complexity: Contractor is required to have successfully completed at least _____ projects of similar type, size and complexity to this project, each with a contract amount of at least \$ _____, within the last _____ years.
- C. List of Completed Projects (Use Form 1, Contractor Experience Detail): Provide a list of all the construction contracts \$ _____ and above your firm has completed within the past _____ years, giving the name of the project; name, address, and phone numbers of Owner and architect representatives; final contract amount; date of completion; and percentage of the cost of the work performed with your firm's own forces. This information will be used for reference reviews.

2.1 EXPERIENCE OF KEY PERSONNEL

- A. Experience of Project Manager (Use Form 2, Résumé of Key Personnel for Proposed Contract): Submit resume and references for the proposed Project Manager. This person shall have managed, as lead project manager, a minimum of _____ projects of similar type, size and complexity to this project, and successfully completed those projects within the last _____ years.
- B. Experience of Superintendent (Use Form 2, Résumé of Key Personnel for Proposed Contract): Submit resume and references for the proposed project Superintendent. This person shall have performed as the lead Superintendent for a minimum of _____ projects of similar type, size and complexity to this project, and successfully completed those projects within the last _____ years.

NISQUALLY STATE PARK
NEW FULL SERVICE PARK Phase 2

3.1 DIVERSE BUSINESS INCLUSION PLAN (USE FORM 3)

- A. Washington state goals are: Minority Business Enterprise (MBE) 10%, Women’s Business Enterprise (WBE) 6%, WA Small Business 5% and WA Veterans 5%. The apparent low bidder is required to submit a Diverse Businesses Inclusion Plan for all projects with a Maximum Allowable Construction Cost (MACC) over \$1M.

The Diverse Business Inclusion plan shall include the apparent low bidder’s anticipated participation goals, the subcontractors anticipated to be used on this project, a list of diverse businesses near the project, the project’s diverse expert, and past performance using diverse businesses.

4.1 APPRENTICESHIP (USE FORMS 1 & 4)

- A. For each public works project with an apprenticeship utilization goal that was completed by the Bidder within three (3) years of the bid submittal date for this project, the Bidder shall submit the following:

- A list of such projects;
- The owner and contact information for the owner’s representative;
- The apprenticeship utilization percentage goal for the project;
- The actual utilization percentage by the Bidder; and
- An explanation of any extenuating circumstances that contributed to the Bidder not meeting the goals.

(Use Form 4 for projects not listed on Form 1)

The Owner may contact previous owners to validate the information provided by the Bidder and shall consider whether the goals were mandatory or voluntary, and the validity of any explanation of extenuating circumstances.

5.1 REFERENCES FROM OWNERS AND ARCHITECTS FOR PREVIOUS PROJECTS
(OWNER USES FORM 5, REFERENCE EVALUATION QUESTIONNAIRE)

- A. The Owner may check references by contacting owners and architects of the bidder’s previous projects regarding the bidder’s performance and that of key staff. A reference score sheet will be utilized and the rating shall be satisfactory or better on a five-category scale with “satisfactory” at mid-scale.

6.1 OVERALL SCORING (FORM 6, RESPONSIBILITY CRITERIA EVALUATION SCORE SHEET)

- A. The Owner will use this form to complete and document the overall evaluation process.

END OF SECTION

Nisqually State Park New Full Service Park Phase 2

Supplemental Bidder Responsibility Form 1 - Contractor Experience Detail

Contractor Information:		
Contractor Legal Name:		Contact Person and their Position/Title:
Project Superintendent:		Project Manager:
Physical Address (Physical and Mailing Addresses are the Same <input type="checkbox"/>):		Mailing Address:
Telephone:	Cell Phone:	Email Address:

Project Information: Is this project relevant to the proposed project? Yes <input type="checkbox"/> No <input type="checkbox"/>	
Project:	Location:
Project Description:	As Prime: <input type="checkbox"/> As Sub: <input type="checkbox"/>
Original Contract Amount: \$ Final Contract Amount: \$	Original Contract Days: Final Contract Days:

Owner Information:	
Owner's Business Name:	Contact Person and their Position/Title:
Mailing Address :	Telephone: Email Address:

Architect/Engineering Information:	
Owner's Business Name:	Contact Person and their Position/Title:
Mailing Address :	Telephone: Email Address:

**Nisqually State Park
New Full Service Park Phase 2**

**Supplemental Bidder Responsibility
Form 2 - Resume of Key Personnel**

Name:	Role in this Contract:	Years Experience	
		Total	With Current Firm
Firm Name and Location (City and State):			
Training/Education/Specialization:			
Years of Experience in the Proposed Role:			

RELEVANT PROJECTS			
Project Title:		Year Completed	
Project Owner:			
Brief Description (Brief scope, size, cost, etc.) and specific role:		Check if project performed with current firm. <input type="checkbox"/>	
		If performed with different firm list the firm name	
Reference Name & Contact Information:			
Project Owner:		Project Architect:	
Name:		Name:	
Phone:		Phone:	
E-mail		E-mail:	

RELEVANT PROJECTS			
Project Title:		Year Completed	
Project Owner:			
Brief Description (Brief scope, size, cost, etc.) and specific role:		Check if project performed with current firm. <input type="checkbox"/>	
		If performed with different firm list the firm name	
Reference Name & Contact Information:			
Project Owner:		Project Architect:	
Name:		Name:	
Phone:		Phone:	
E-mail		E-mail:	

RELEVANT PROJECTS			
Project Title:		Year Completed	
Project Owner:			
Brief Description (Brief scope, size, cost, etc.) and specific role:		Check if project performed with current firm. <input type="checkbox"/>	
		If performed with different firm list the firm Name	
Reference Name & Contact Information:			
Project Owner:		Project Architect:	
Name:		Name:	
Phone:		Phone:	
E-mail		E-mail:	

**Nisqually State Park
New Full Service Park Phase 2**

RELEVANT PROJECTS		
Project Title:	Year Completed	
Project Owner:		
Brief Description (Brief scope, size, cost, etc.) and specific role:	Check if project performed with current firm. <input type="checkbox"/> If performed with different firm list the firm Name	
Reference Name & Contact Information:		
Project Owner:		Project Architect:
Name:		Name:
Phone:		Phone:
E-mail		E-mail:

RELEVANT PROJECTS		
Project Title:	Year Completed	
Project Owner:		
Brief Description (Brief scope, size, cost, etc.) and specific role:	Check if project performed with current firm. <input type="checkbox"/> If performed with different firm list the firm Name	
Reference Name & Contact Information:		
Project Owner:		Project Architect:
Name:		Name:
Phone:		Phone:
E-mail		E-mail:

RELEVANT PROJECTS		
Project Title:	Year Completed	
Project Owner:		
Brief Description (Brief scope, size, cost, etc.) and specific role:	Check if project performed with current firm. <input type="checkbox"/> If performed with different firm list the firm Name	
Reference Name & Contact Information:		
Project Owner:		Project Architect:
Name:		Name:
Phone:		Phone:
E-mail		E-mail:

**Nisqually State Park
New Full Service Park Phase 2**

**Supplemental Bidder Responsibility
Form 3 - Prime Contractor Diverse Business Inclusion Plan**

Prime Contractor Name: _____

For the purposes of this form, Washington State-certified diverse businesses are defined as follows:

- *Minority Business Enterprise (MBE)*, *Women’s Business Enterprise (WBE)*, or combination of the two. Certified by the Office of Minority and Women’s Business Enterprises (OMWBE): <http://omwbe.wa.gov/>
- *Veteran-owned Business*. Certified by the Department of Veteran’s Affairs (DVA): <http://dva.wa.gov/>
- *Small Business* (includes Mini and Micro businesses). Certified through the Washington Electronic Business Solution (WEBS): <https://fortress.wa.gov/ga/webs/home.html>

Anticipated Certified Diverse Business Participation Goals

Subcontracting means direct performance of commercially useful work through subcontracting as part of the proposed project team. Of the total contract work, what are the diverse business participation goals proposed for subcontracting on your team? Please only include the above-listed Washington State certification types in your “Contractor-defined Anticipated Percent of Contract Amount (Goals)” estimate. Zero percent (0%) is not a goal.

Anticipated Certified Diverse Business Participation Goals	Washington State Goals	Contractor-defined Anticipated Percent of Contract Amount (Goals)
Minority-owned business (MBE)	10%	%
Women-owned business (WBE)	6%	%
Veteran-owned business (DVA)	5%	%
Small business	5%	%

Subcontracting Team

List the names of the diverse businesses you anticipate using on this project. Generally describe the work you expect the diverse business to perform and identify the percent of total contract value intended for each diverse business. Please include the above-listed Washington State certification types. *If necessary, add more rows below.*

Name of Diverse Business	Specify Diverse Business Certification (circle one or more)	Describe Trade or Task	Anticipated Percent of Contract Amount
	MBE, WBE, DVA, Small		%
	MBE, WBE, DVA, Small		%
	MBE, WBE, DVA, Small		%
	MBE, WBE, DVA, Small		%
	MBE, WBE, DVA, Small		%

Attach a list of diverse businesses near the project location to this form:

1. Go to <https://omwbe.wa.gov/directory-certified-firms>
2. Click on “OMWBE DIRECTORY”
3. Click on “Search Certified Firm Directory”
4. Select MBE, MWBE, SBE, and WBE certifications.
5. Enter a City, Zip Code, or County near the project site address and then press “Search” at the bottom of the page. If you do not have many results, please expand your search to include nearby locations.
6. Print and attach the results to this form with your submittal

Diverse Expert:

Diverse Expert responsibilities would typically include, but are not limited to:

- Outreach to qualified diverse businesses.
- Submit and discuss updates on a regular basis to the state project manager regarding Diverse Business utilization and progress.

Nisqually State Park New Full Service Park Phase 2

- Ongoing outreach to diverse businesses for required contract work, including any changes in scope.
- Assist diverse businesses with successful contract performance.

A qualified Diverse Expert brings knowledge of the identity, capabilities and capacities of diverse business subcontractors and suppliers; experience recruiting and working with diverse businesses for construction; and assisting diverse businesses to develop working relationships with contractors.

Identify the person within your team to manage your diverse inclusion responsibility.

Diverse Expert Name: _____

Diverse Expert Contact Information: _____

Diverse Expert Firm (if another firm is managing participation): _____

Past Performance

Please select **five (5) of your projects** with Washington State-certified diverse business participation (MBE, WBE, DVA, and/or Small/Mini/Micro) and list them below **for the last five (5) years**. If you do not have any projects that tracked or reported diverse business participation, you may leave this section blank. In that case, please attach an additional sheet with explanation.

You may have projects with diverse business participation for an organization or entity that required *different* diverse business categories (including self-certification). If so, please attach a sheet with the same column data and information, but include percentages for the categories that were tracked during the project.

Contract Name	Contracting Agency or Entity	Contract Amount	Year	Percent of Contract Amount	
				Minority-owned business:	%
				Women-owned business:	%
				Veteran-owned business:	%
				Small/mini/micro business:	%
Contract Name	Contracting Agency or Entity	Contract Amount	Year	Percent of Contract Amount	
		\$		Minority-owned business:	%
				Women-owned business:	%
				Veteran-owned business:	%
				Small/mini/micro business:	%
Contract Name	Contracting Agency or Entity	Contract Amount	Year	Percent of Contract Amount	
		\$		Minority-owned business:	%
				Women-owned business:	%
				Veteran-owned business:	%
				Small/mini/micro business:	%
Contract Name	Contracting Agency or Entity	Contract Amount	Year	Percent of Contract Amount	
		\$		Minority-owned business:	%
				Women-owned business:	%
				Veteran-owned business:	%
				Small/mini/micro business:	%
Contract Name	Contracting Agency or Entity	Contract Amount	Year	Percent of Contract Amount	
		\$		Minority-owned business:	%
				Women-owned business:	%
				Veteran-owned business:	%
				Small/mini/micro business:	%

Nisqually State Park New Full Service Park Phase 2

Supplemental Bidder Responsibility Form 4 – Apprenticeship Utilization

Contractor Information:		
Contractor Legal Name:		Contact Person and their Position/Title:
Project Superintendent:		Project Manager:
Physical Address (Physical and Mailing Addresses are the Same <input type="checkbox"/>):		Mailing Address:
Telephone:	Cell Phone:	Email Address:

Project Information: Is this project relevant to the proposed project? Yes <input type="checkbox"/> No <input type="checkbox"/>	
Project:	Location:
Project Description:	As Prime: <input type="checkbox"/> As Sub: <input type="checkbox"/>
Original Contract Amount: \$ Final Contract Amount: \$	Original Contract Days: Final Contract Days:

Owner Information:	
Owner's Business Name:	Contact Person and their Position/Title:
Mailing Address :	Telephone: Email Address:

Architect/Engineering Information:	
Owner's Business Name:	Contact Person and their Position/Title:
Mailing Address :	Telephone: Email Address:

1. Did this project require Apprenticeship Participation? Yes No (If NO, stop here)
2. If yes, what was the Apprenticeship percentage? _____ %
3. What was the actual percentage achieved? _____ %
4. Was the apprenticeship requirement met? Yes No
5. If NO to question 4, explain Why.

**Nisqually State Park
New Full Service Park Phase 2**

**Supplemental Bidder Responsibility
Form 5 - Reference Evaluation Questionnaire**

Evaluated Firm :
Project Manager:
Superintendent:
Evaluated Project Name:

- Prime
 Subcontractor

Approx. Start Date	Approx. End Date	Approx. Final Project Cost

PERFORMANCE EVALUATION

Rating Criteria - Rate on a scale of 1 to 5

- **5 = Superior** based on performance (would hire this firm/individual again)
- **4 = More than Satisfactory**
- **3 = Satisfactory** based on performance (would hire this firm/individual again)
- **2 = Less than Satisfactory**
- **1= Totally Unsatisfactory** based on performance (would never hire the firm/individual again)

Criteria	Rating		
	Company	PM	Super
1 Ability to meet client's expectations			
2 Quality of workmanship			
3 Ability to manage project costs and minimize change orders			
4 Ability to maintain project schedule			
5 Ability to manage subcontractors			
6 Professionalism, leadership and communication in issues management (RFI, shop drawing submittal, timely resolution of issues/questions)			
7 Ability to follow the owner's rules, regulations, and requirements (housekeeping, safety, etc.)			
8 Ability to manage closeout process (Prompt submittal of punch list, warranty, as-builts, operation manuals, tax clearances, etc.)			
9 Comfort level in hiring firm or individual again based on performance			
Total Score			
Average Score			

Evaluator Information	
Name of Evaluator:	Title:
Firm/Company Name:	
Firm Address:	
Phone:	Email:

Form 6 – Supplemental Responsibility Criteria Evaluation Score Sheet

Project Location _____
 Project Name _____
 Contract Number _____
 Project Representative _____

1. Experience of Contractor - On projects of similar size & complexity (Form 1)	Pass or Fail
--	--------------

2. Experience of Key Personnel (Form 2)	
Superintendent	Pass or Fail
Project Manager	Pass or Fail
Other(s) if specified in Division 00	Pass or Fail

3. Diverse Business Inclusion Plan (Form 3) <i>(Applies only to projects with Diverse Business Plan Inclusion requirements; i.e. MACC over \$1M)</i>	Pass, Fail, or N/A
---	--------------------

4. Contractor Compliance with Apprenticeship Requirements - Requirements were met or if not, a good faith effort was demonstrated (Forms 1 & 4) <i>Applies only to projects with apprenticeship participation requirements; i.e. MACC over \$1M</i>	Not Scored
--	------------

5. References from Previous Projects (Form 5) Evaluate contractor's references information and using the rating numbers: 1 = NOT Satisfactory (requires a written comment below) 2 = Less THAN Satisfactory 3 = Satisfactory 4 = More THAN Satisfactory 5 = Superior	Rating Score 1-5 (3 is Satisfactory)
Company	
Project Manager	
Superintendent	
Total Score:	
Average score (divide total score by number of ratings)	

In determining the bidder responsibility, an overall accounting of the ratings shall be made. A score of "Pass" is required for categories 1 - 4 and an average score of 3.0 or higher is required to meet the minimum Supplemental Bidder Responsibility requirements.

Comments _____

Determination Responsible
 Not Responsible (Preliminary Determination)

Evaluated by _____ Date _____
 State Parks Project Representative

Signature _____

**NISQUALLY STATE PARK
NEW FULL SERVICE PARK – PHASE 2**

The following list of major items of construction has been included for Bidder's convenience in preparing a bid proposal. Exclusion of items from this summary does not indicate exclusion from project. For lump sum items, the bidder is cautioned that the drawings are the only source for measurement of project quantities, and drawings have been detailed for this purpose. In preparing a bid proposal, Bidder should note apparent discrepancies between the list below and the drawings and consult with Landscape Architect for verification.

SCHEDULE A – STAFF RESIDENCE & ADMINISTRATION BUILDING BASE BID ITEMS

BID ITEM	DESCRIPTION	ESTIMATED QUANTITY	PAYMENT
A1	TRENCH EXCAVATION SAFETY PROVISIONS	1	PER LUMP SUM
	See instructions on Bid Proposal Form. This Bid Item applies to both Schedule A and B work.		
A2	MOBILIZATION	1	PER LUMP SUM
	This Bid Item shall comply with WSDOTSS 1-09.7 Mobilization. This Bid Item applies to both Schedule A and B work.		
A3	STAFF RESIDENCE AND ADMINISTRATION BUILDING	1	PER LUMP SUM
	This Bid Item includes all work in the Contract Document to provide the Staff Residence and Administration Building in place, complete, and operational. This Bid Item includes, but is not limited to, providing all materials, labor, equipment, overhead, profit for the construction of the Staff Residence and Administration Building.		
	This Bid Item includes, but is not limited to providing survey, clearing, selective clearing, grubbing, excavation, grading, on/off site haul, temporary and permanent erosion control, aggregates, gates, fencing, gate plinths, signage, kiosks, Administrative Building, Staff Residence, hot mix asphalt paving, boulder processing & placement, site electrical improvements, site furnishings, concrete blocks, signage/stripping, concrete paving, installation of Owner provided Art and site furnishings, access barriers, topsoil, plants, wood chips, mulch, and all work described in the Plans and Project Manual. Clearing and Grubbing the Borrow Pit, and any Borrow Pit Haul Route restoration shall be paid for under the Lump Sum Bid Item “Staff Residence and Administrative Building”. This Bid Item will be measured and paid for on a Lump Sum basis under the Bid Item “Staff Residence and Administrative Building”.		
A4	COMMON BORROW A	6525	PER NEAT LINE CUBIC YARD
	Includes all work associated with excavating, loading, hauling, placing, compacting, and grading Common Borrow A from the Owner provided Borrow Pit and placed within the Work area of the Bid Item “Staff Residence And Administration Building”. This Bid also includes the cost of Clearing and Grubbing the Borrow Pit and any Haul Road preparation and restoration. Common Borrow A will be measured per Cubic Yard on a Neat Line basis. Measurement will be based upon the Contractor provided topographical survey of the Post Grubbing/Pre-Fill subgrade surface elevations and the design elevations of the Common Borrow A subgrade. The Contractor is required to conduct Post Grubbing/Pre-Fill survey and provide the survey file to a third-party earthwork calculation firm preapproved by Owner who will perform the earthwork calculations		

**NISQUALLY STATE PARK
NEW FULL SERVICE PARK – PHASE 2**

which will be used for as the basis for measurement and payment of Common Borrow A. This Bid Item will be measured and paid for on a per Neat Line Cubic Yard basis under the Bid Item “Common Borrow A”.

SCHEDULE B – NISQUALLY/OHOP ACCESS BASE BID ITEMS

BID ITEM	DESCRIPTION	ESTIMATED QUANTITY	PAYMENT
B1	NISQUALLY/OHOP ACCESS IMPROVEMENTS	1	PER LUMP SUM
	<p>This Bid Item includes all work in the Contract Document to provide the Nisqually/Ohop Access Improvements in place, complete, and operational. The Bid Item includes, but is not limited to, all materials, labor, equipment, overhead, profit for the construction of the Bus Parking, the Trailhead, Nisqually River Access Trail, Boardwalk, and all three Overlooks.</p> <p>This Bid Item includes, but is not limited to, survey, clearing, selective clearing, grubbing, excavation, grading, on/off site haul, temporary and permanent erosion control, aggregates, grading, fencing, signage, boulder processing & placement, kiosks, prefabricated restrooms, hot mix asphalt paving, concrete paving and steps, handrails, site furnishings, signage/stripping, Disposal Site construction, access barriers, topsoil, plants, wood chips, and all work described in the Plans and Project Manual. This Bid Item will be measured and paid for on a Lump Sum Basis under the Bid Item “Nisqually/Ohop Access Improvements”.</p>		
B2	COMMON BORROW A	1100	PER NEAT LINE CUBIC YARD
	<p>Includes all work associated with excavating, loading, hauling, placing, compacting, and grading Common Borrow A from the Owner provided Borrow Pit and placed within the Work area of the Bid Item “Nisqually/Ohop Access Improvements”. This Bid also includes the cost of Clearing and Grubbing the Borrow Pit and any Haul Road preparation and restoration. Common Borrow A will be measured per Cubic Yard on a Neat Line basis. Measurement will be based upon the Contractor provided topographical survey of the Post Grubbing/Pre-Fill subgrade surface elevations and the top design elevations of the Common Borrow A subgrade. The Contractor is required to conduct Post Grubbing/Pre-Fill survey and provide the survey file to a third-party earthwork calculation firm preapproved by Owner who will perform the earthwork calculations which will be used for as the basis for measurement and payment of Common Borrow A. This Bid Item will be measured and paid for on a per Neat Line Cubic Yard basis under the Bid Item “Common Borrow A”.</p>		
B3.	ROADWAY IMPROVEMENTS	1	PER LUMP SUM
	<p>This Bid Item includes all work in the Contract Document to provide the Roadway Improvements in place, complete, and operational. The Bid Item includes, but is not limited to, providing all materials, labor, equipment, overhead, and profit for the construction of Roadway Improvements. This Bid Item includes all work between Station 4+75 – Station 39+70 and Station 42+45 – Station 71+55. Roadway Improvements. Stationing has been measured by Landscape Architect with measuring wheel and may vary in length. Contractor shall determine their own measurements and their own quantities prior to Bidding and be responsible for construction of entire Roadway Improvements.</p>		

**NISQUALLY STATE PARK
NEW FULL SERVICE PARK – PHASE 2**

This Bid Item for Roadway Improvement includes, but is not limited to, survey, clearing, selective clearing, grubbing, excavation, grading, on site haul, temporary and permanent erosion control, aggregates, installation of Owner provided Art and site furnishings, signage, concrete paving, and all Roadway Improvements work described in the Plans and Project Manual. This Bid Item will be measured and paid for on a Lump Sum Basis under the Bid Item “Roadway Improvements”.

SCHEDULE C – ALTERNATE BID ITEMS

BID ITEM	DESCRIPTION	ESTIMATED QUANTITY	PAYMENT
C1	OVERLOOK 1 SPUR TRAIL	1	PER LUMP SUM

This Alternate Bid Item includes all work in the Contract Document to provide the Overlook 1 Spur Trail Improvements in place, complete, and operational. The Bid Item includes, but is not limited to, all materials, labor, equipment, overhead, profit for the construction of the Overlook 1 Spur Trail.

END OF SECTION



NISQUALLY STATE PARK
NEW FULL-SERVICE PARK – PHASE 2

BIDS DUE:
1:00PM, THURSDAY,
MAY 16, 2024

BID DELIVERY LOCATION:

DELIVER BIDS ELECTRONICALLY TO [BIDBOX@PARKS.WA.GOV](mailto:bidbox@parks.wa.gov)

Subject line to read: “NW-C1218 [YOUR COMPANY NAME].”

***** Bid Proposal and Signature: See Sections 7.1 and 11.1 of the Instructions to Bidders for expanded instructions for bid submittal. *****

**** PLEASE PRINT CLEARLY BELOW ****

TOTAL BASE BID	
(INCLUDES SCHEDULES A & B)	
(NOT INCLUDING SALES TAX)	
↓ PRICE WRITTEN-OUT COMPLETELY IN WORDS ↓	↓ PRICE IN NUMBERS ONLY ↓
<hr/> <hr/> _____ (U.S.) DOLLARS	\$ _____

Printed Name of Person Signing Bid Proposal ↑	Firm Name (Printed legibly) ↑
Title ↑ (Estimator, Vice-President, Owner, Principal, etc.)	Physical Street Address ↑ (NO PO Boxes Here)
Contractor Registration No. & Expiration Date ↑	City ↑ State Zip + PLUS 4
Taxpayer Identification Number ↑	() Area Code Phone Number ↑
Washington UBI Number ↑	() Area Code Fax Number ↑
Employment Security Department Number ↑	() Area Code Cellular Phone Number ↑
PO Box for US Mail Delivery (if any) ↑	E-Mail Address (Enter N/A if none) ↑



**NISQUALLY STATE PARK
NEW FULL-SERVICE PARK – PHASE 2**

Unit prices and estimated quantities shall be used to determine the Base Bid. These prices shall also be used to adjust the Contract in the event there is an increase or decrease in the estimated quantities. All costs shall be “in place” costs and complete, **excluding State Sales Tax.** *In the event of an irregularity, the unit price prevails. The Owner reserves the right to make mathematical corrections of multiplication or addition errors on the bid form.*

Trench Excavation Safety Provisions: If the contract contains any work which requires trenching exceeding a depth of four (4) feet, all costs for adequate trench safety systems shall be identified as a separate bid item in compliance with Chapter 39.04 RCW. The purpose of this provision is to ensure that the bidder agrees to comply with all relevant trench safety requirements of Chapter 49.17 RCW. This bid amount shall be considered part of the total base bid. **Include a lump sum dollar amount (even if the value is \$0.00) to be considered responsive to the bid solicitation.**

Wage Certification. The bidder certifies under penalty of perjury under the laws of the State of Washington that the foregoing is true and correct: within the three-year period immediately preceding the bid solicitation date, the bidder has not been a “willful” violator, as defined in RCW 49.48.082, of any provision of chapters 49.46, 49.48, or 49.52 RCW, as determined by a final and binding citation and notice of assessment issued by the Department of Labor and Industries or through a civil judgment entered by a court of limited or general jurisdiction.

SCHEDULE A - STAFF RESIDENCE & ADMINSTRATIVE BUILDING IMPROVEMENTS

BASE BID ITEMS

BE SURE TO INCLUDE UNIT PRICES IF THE BOX IS NOT SHADED

ITEM NO.	DESCRIPTION	EST QTY	UNIT PRICE	TOTAL AMOUNT
A1.	Trench Excavation Safety Provisions per Lump Sum	1		
A2.	Mobilization per Lump Sum	1		
A3.	Staff Residence & Administrative Building per Lump Sum	1		
A4.	Common Borrow A per Neat Line Cubic Yard	6525		
SCHEDULE A SUBTOTAL →				\$



**NISQUALLY STATE PARK
NEW FULL-SERVICE PARK – PHASE 2**

SCHEDULE B – NISQUALLY/OHOP ACCESS IMPROVEMENTS

BASE BID ITEMS

BE SURE TO INCLUDE UNIT PRICES IF THE BOX IS NOT SHADED

ITEM NO.	DESCRIPTION	EST QTY	UNIT PRICE	TOTAL AMOUNT
B1	Nisqually/Ohop Access Improvements per Lump Sum	1		
B2	Common Borrow A per Neat Line Cubic Yard	1100		
B3	Roadway Improvements per Lump Sum	1		
SCHEDULE B SUBTOTAL				

SCHEDULE C - ALTERNATE BID ITEMS

ITEM NO.	DESCRIPTION	EST QTY	UNIT PRICE	TOTAL AMOUNT
C1	Overlook 1 Spur Trail	L.S.		

Minority and Women’s Business Enterprises (MWBE), WA Small Business, WA Veteran-Owned Business Utilization Certification: The bidder certifies good faith efforts to provide opportunities to MWBEs, Small Businesses, and Veteran-Owned Businesses. If awarded, the bidder commits to utilizing these firms or approved substitutes on the project. If no such firms will be used, enter "N.A." on the first line.

Firm Name, Address and Federal I.D. #	Type of Work	Certificate Number	MBE%	WBE%	Small Business%	Veteran Business%
1						
2						
TOTALS						

Bidder may attach a separate sheet for additional MWBE/Small Business/Veteran-Owned Business Utilization Certification.



**NISQUALLY STATE PARK
NEW FULL-SERVICE PARK – PHASE 2**

The Bidder declares that they have carefully examined the site of the proposed work, the Drawings, Specifications and all of the conditions affecting the work. Therefore, the Bidder proposes to provide all labor, equipment, materials, and permits and to perform all work as required by, and in strict accordance with the Contract Documents for the bid amounts as follows.

The Commission reserves the right to accept or reject all bids and to waive informalities. No withdrawal of bids after bid deadline, or before award of contract, unless award is delayed over thirty (30) days.

Bidder agrees to complete project (including accepted alternates) in accordance with drawings and specifications within **365** calendar days from the date provided on the Notice to Proceed letter.

It is agreed that liquidated damages, in the amount of **\$500.00**, shall be levied for each and every calendar day by which the completion of the work is delayed beyond the time fixed for completion or extension of the contract.

Apprentice Utilization Requirements. The apprentice labor hours required for this project are 15% of the total labor hours. The undersigned agrees to utilize this level of apprentice participation. A monetary incentive of \$1,000.00 will be paid to the contractor meeting the apprentice utilization requirement. A monetary penalty will be applied to the contractor failing to meet the utilization requirement and failing to demonstrate a Good Faith Effort. The penalty will be \$100.00 per percentage point not utilized.

Expected Apprenticeship Utilization cost value to be included in the bid associated with meeting the goals: \$ _____.

Addenda: Receipt of addenda numbered [] through [] is hereby acknowledged.

Signature of Authorized Official



**NISQUALLY STATE PARK
NEW FULL-SERVICE PARK – PHASE 2**

SUBCONTRACTORS UTILIZATION LIST

In compliance with the contract documents, the following subcontractor list is submitted:

SUBCONTRACTOR LISTING – RCW 39.30.060

If the base bid and the sum of the additive alternates is one million dollars or more, the Bidder shall provide names of the subcontractors with whom the Bidder will **directly** subcontract for performance of the following work. If the Bidder intends to perform the work, the Bidder must enter its name for that category of work.

- A. Submission Deadline: The completed and signed Subcontractors List must be submitted with bid.
- B. List Subcontractors: The Bidder shall indicate on the Subcontractors List the names of the subcontractors with whom the Bidder, if awarded the contract, will directly subcontract for performance of the work of heating, ventilation, and air conditioning, plumbing as described in Chapter 18.106 RCW, electrical as described in Chapter 19.28 RCW, structural steel installation, and rebar installation.
- C. List Bidder if Bidder Performing Work: If the Bidder will self-perform the work in any of the five areas required, the Bidder shall name itself for the work on the Subcontractors List.
- D. Name Only One Firm for Each Category of Work: The Bidder shall not list more than one firm (subcontractor or Bidder) for each category of work identified, unless subcontractors vary with bid Alternatives or Additives, in which case the Bidder must indicate which firm will be used for which Alternate or Additive.
- E. Substitution of Subcontractors: Substitution of any listed subcontractor may only be according to the procedure and parameters set forth in RCW 39.30.060.
- F. Factors Relating to Non-Responsiveness: **Failure of the Bidder to submit the names of such subcontractors or to name itself to perform such work or the naming of two or more firms (subcontractors or Bidder) to perform the same work shall render the Bidder's bid nonresponsive and, therefore, VOID.**
- G. Applicable to Direct Subcontractors: The requirement of this section to name the Bidders' proposed heating, ventilation and air conditioning, plumbing, electrical, structural steel installation, and rebar installation subcontractors applies only to proposed heating, ventilation and air conditioning, plumbing, electrical, structural steel installation, and rebar installation subcontractors who will contract directly with the Bidder.



**NISQUALLY STATE PARK
NEW FULL-SERVICE PARK – PHASE 2**

1. HVAC, Electrical, Plumbing: The requirement of this section to name the bidder’s proposed heating, ventilation and air conditioning, plumbing and electrical subcontractors applies only to proposed heating, ventilation, and air conditioning, plumbing and electrical subcontractors who will contract directly with the bidder.

Category of Work	Bidder MUST check one box for each Category of Work. If subcontracting the work, bidder must name the subcontractor.
HVAC (Heating, Ventilation & Air Conditioning)	<input type="checkbox"/> Name of Subcontractor: _____ <input type="checkbox"/> Bidder will self-perform this work, or the project does not include this work.
Electrical	<input type="checkbox"/> Name of Subcontractor: _____ <input type="checkbox"/> Bidder will self-perform this work, or the project does not include this work.
Plumbing	<input type="checkbox"/> Name of Subcontractor: _____ <input type="checkbox"/> Bidder will self-perform this work, or the project does not include this work.

Bidder may attach a separate sheet for additional alternate bid subcontractors

2. Structural Steel Installation and Rebar Installation: The requirement of this section to name the bidder’s proposed names of the subcontractors with whom the bidder, if awarded, will subcontract for performance of the work of structural steel installation and rebar installation.

Category of Work	Bidder MUST check one box for each Category of Work. If subcontracting the work, bidder must name the subcontractor.
Structural Steel Installation	<input type="checkbox"/> Name of Subcontractor: _____ <input type="checkbox"/> Bidder will self-perform this work, or the project does not include this work.
Rebar Installation	<input type="checkbox"/> Name of Subcontractor: _____ <input type="checkbox"/> Bidder will self-perform this work, or the project does not include this work.

Bidder may attach a separate sheet for additional alternate bid subcontractors

Signature of Authorized Official

GENERAL CONDITIONS FOR CONSTRUCTION AT WASHINGTON STATE PARKS

<u>Part</u>	<u>Page</u>	<u>Part</u>	<u>Page</u>
PART 1 GENERAL PROVISIONS		5.15 Tests and Inspection	20
1.01 Definitions	2	5.16 Correction of Nonconforming Work	21
1.02 Order of Precedence	3	5.17 Clean Up	22
1.03 Execution and Intent	4	5.18 Access to Work	22
PART 2 INSURANCE AND BONDS		5.19 Other Contracts	22
2.01 Contractor's Liability Insurance	4	5.20 Subcontractors and Suppliers	22
2.02 Coverage Limits	5	5.21 Warranty of Construction	23
2.03 Insurance Coverage Certificates	6	5.22 Indemnification	23
2.04 Payment and Performance Bonds	6	PART 6 PAYMENTS AND COMPLETION	
2.05 Alternative Surety	6	6.01 Contract Sum	24
2.06 Builder's Risk	6	6.02 Schedule of Values	24
PART 3 TIME AND SCHEDULE		6.03 Application for Payment	24
3.01 Progress and Completion	7	6.04 Progress Payments	25
3.02 Construction Schedule	7	6.05 Payments Withheld	25
3.03 Owner's Right to Suspend the Work for Convenience	8	6.06 Retainage and Bond Claim Rights	25
3.04 Owner's Right to Stop the Work for Cause	8	6.07 Substantial Completion	26
3.05 Delay	8	6.08 Prior Occupancy	26
3.06 Notice to Owner of Labor Disputes	9	6.09 Final Completion, Acceptance, and Payment	26
3.07 Damages for Failure to Achieve Timely Completion	9	PART 7 CHANGES	
PART 4 SPECIFICATIONS, DRAWINGS, AND OTHER DOCUMENTS		7.01 Changes in the Work	27
4.01 Discrepancies and Contract Document Review	10	7.02 Change in the Contract Sum	27
4.02 Project Record	10	7.03 Change in the Contract Time	32
4.03 Submittals	10	PART 8 CLAIMS AND DISPUTE RESOLUTION	
4.04 Organization of Specifications	11	8.01 Claims Procedure	34
4.05 Ownership and Use of Drawings, Specifications, and Other Documents	11	8.02 Arbitration	35
PART 5 PERFORMANCE		8.03 Claims Audits	35
5.01 Contractor Control and Supervision	12	PART 9 TERMINATION OF THE WORK	
5.02 Permits, Fees and Notices	13	9.01 Termination by Owner for Cause	36
5.03 Patents and Royalties	13	9.02 Termination by Owner for Convenience	37
5.04 Prevailing Wages	13	PART 10 MISCELLANEOUS PROVISIONS	
5.05 Hours of Labor	14	10.01 Governing Law	38
5.06 Nondiscrimination	14	10.02 Successors and Assigns	38
5.07 Safety Precautions	15	10.03 Meaning of Words	38
5.08 Operations, Material Handling, and Storage Areas	17	10.04 Rights and Remedies	38
5.09 Prior Notice of Excavation	17	10.05 Contractor Registration	38
5.10 Unforeseen Physical Conditions	18	10.06 Time Computations	38
5.11 Protection of Existing Structures, Equipment, Vegetation, Utilities, and Improvements	18	10.07 Records Retention	38
5.12 Layout of Work	19	10.08 Third-Party Agreements	39
5.13 Material and Equipment	19	10.09 Antitrust Assignment	39
5.14 Availability and Use of Utility Services	20	10.10 Minority & Women's Business Enterprises (MWBE) Participation	39
		10.11 Minimum Levels of Apprenticeship Participation	40
		10.12 Headings and Captions	41

GENERAL CONDITIONS FOR CONSTRUCTION AT WASHINGTON STATE PARKS

PART 1 - GENERAL PROVISIONS

1.01 DEFINITIONS

- A. "Application for Payment" means a written request submitted by Contractor to A/E for payment of Work completed in accordance with the Contract Documents and approved Schedule of Values, supported by such substantiating data as Owner or A/E may require.
- B. "Architect," "Engineer," or "A/E" shall mean that person designated by the State Parks and Recreation Commission to be in charge of the work covered by this contract.
- C. "Change Order" means a written instrument signed by Owner and Contractor stating their agreement upon all of the following: (1) a change in the Work; (2) the amount of the adjustment in the Contract Sum, if any, and (3) the extent of the adjustment in the Contract Time, if any.
- D. "Claim" means Contractor's exclusive remedy for resolving disputes with Owner regarding the terms of a Change Order or a request for equitable adjustment, as more fully set forth in part 8.
- E. "Contract Award Amount" is the sum of the Base Bid and any accepted Alternates.
- F. "Contract Documents" means the Advertisement for Bids, Instructions for Bidders, completed Form of Proposal, General Conditions, Modifications to the General Conditions, Supplemental Conditions, Public Works Contract, other Special Forms, Drawings and Specifications, and all addenda and modifications thereof.
- G. "Contract Sum" is the total amount payable by Owner to Contractor for performance of the Work in accordance with the Contract Documents, including all taxes imposed by law and properly chargeable to the Work, except Washington State sales tax.
- H. "Contract Time" is the number of calendar days allotted in the Contract Documents for achieving Substantial Completion of the Work.
- I. "Contractor" means the person or entity who has agreed with Owner to perform the Work in accordance with the Contract Documents.
- J. "Drawings" are the graphic and pictorial portions of the Contract Documents showing the design, location, and dimensions of the Work, and may include plans, elevations, sections, details, schedules, and diagrams.
- K. "Final Acceptance" means the written acceptance issued to Contractor by Owner after Contractor has completed the requirements of the Contract Documents, as more fully set forth in Section 6.09 B.
- L. "Final Completion" means that the Work is fully and finally completed in accordance with the Contract Documents, as more fully set forth in Section 6.09 A.
- M. "Force Majeure" means those acts entitling Contractor to request an equitable adjustment in the Contract Time, as more fully set forth in paragraph 3.05 A.
- N. "Notice" means a written notice which has been delivered in person to the individual or a member of the firm or entity or to an officer of the corporation for which it was intended or, if delivered or sent by registered or certified mail, to the last business address known to the party giving notice.
- O. "Notice to Proceed" means a notice from Owner to Contractor that defines the date on which the Contract Time begins to run.
- P. "Owner" shall mean the Washington State Parks and Recreation Commission and its authorized representative with the authority to enter into, administer and/or terminate contracts and make related determinations and findings.
- Q. "Person" means a corporation, partnership, business association of any kind, trust, company, or individual.

GENERAL CONDITIONS FOR CONSTRUCTION AT WASHINGTON STATE PARKS

- R. "Prior Occupancy" means Owner's use of all or parts of the Project before Substantial Completion, as more fully set forth in Section 6.08 A.
- S. "Progress Schedule" means a schedule of the Work, in a form satisfactory to Owner, as further set forth in section 3.02.
- T. "Project" means the total construction of which the Work performed in accordance with the Contract Documents may be the whole or a part and which may include construction by Owner or by separate contractors.
- U. "Project Manual" means the volume usually assembled for the Work which may include the bidding requirements, sample forms, and other Contract Documents.
- V. "Project Record" means the separate set of Drawings and Specifications as further set forth in paragraph 4.02A.
- W. "Schedule of Values" means a written breakdown allocating the total Contract Sum to each principle category of Work, in such detail as requested by Owner.
- X. "Specifications" are that portion of the Contract Documents consisting of the written requirements for materials, equipment, construction systems, standards, and workmanship for the Work, and performance of related services.
- Y. "Subcontract" means a contract entered into by Subcontractor for the purpose of obtaining supplies, materials, equipment, or services of any kind for or in connection with the Work.
- Z. "Subcontractor" means any person, other than Contractor, who agrees to furnish or furnishes any supplies, materials, equipment, or services of any kind in connection with the Work.
- AA. "Substantial Completion" means that stage in the progress of the Work where Owner has full and unrestricted use and benefit of the facilities for the purposes intended, as more fully set forth in section 6.07.
- AB. "Work" means the construction and services required by the Contract Documents, and includes, but is not limited to, labor, materials, supplies, equipment, services, permits, and the manufacture and fabrication of components, performed, furnished, or provided in accordance with the Contract Documents.

1.02 ORDER OF PRECEDENCE

Any conflict or inconsistency in the Contract Documents shall be resolved by giving the documents precedence in the following order.

1. Signed Public Works Contract, including any Change Orders, and any Special Forms.
2. Supplemental Conditions.
3. General Conditions.
4. Addenda
5. Specifications--provisions in Division 1 shall take precedence over provisions of any other Division.
6. Drawings--in case of conflict within the Drawings, large scale drawings shall take precedence over small scale drawings.
7. Signed and Completed Form of Proposal.
8. Instructions to Bidders.
9. Advertisement for Bids.

GENERAL CONDITIONS FOR CONSTRUCTION AT WASHINGTON STATE PARKS

1.03 EXECUTION AND INTENT

Contractor makes the following representations to Owner:

1. The Contract Sum is reasonable compensation for the Work and the Contract Time is adequate for the performance of the Work, as represented by the Contract Documents;
2. Contractor has carefully reviewed the Contract Documents, visited and examined the Project site, become familiar with the local conditions in which the Work is to be performed, and satisfied itself as to the nature, location, character, quality and quantity of the Work, the labor, materials, equipment, goods, supplies, work, services and other items to be furnished and all other requirements of the Contract Documents, as well as the surface and subsurface conditions and other matters that may be encountered at the Project site or affect performance of the Work or the cost or difficulty thereof;
3. Contractor is financially solvent, able to pay its debts as they mature, and possesses sufficient working capital to complete the Work and perform Contractor's obligations required by the Contract Documents; and
4. Contractor is able to furnish the plant, tools, materials, supplies, equipment and labor required to complete the Work and perform the obligations required by the Contract Documents and has sufficient experience and competence to do so.

PART 2 - INSURANCE AND BONDS

2.01 CONTRACTOR'S LIABILITY INSURANCE

Prior to commencement of the Work, Contractor shall obtain all the insurance required by the Contract Documents and provide evidence satisfactory to Owner that such insurance has been procured. Review of the Contractor's insurance by Owner shall not relieve or decrease the liability of Contractor. Companies writing the insurance to be obtained by this part shall be licensed to do business under Chapter 48 RCW or comply with the Surplus Lines Law of the State of Washington. Contractor shall include in its bid the cost of all insurance and bond costs required to complete the base bid work and accepted alternates. Insurance carriers providing insurance in accordance with the Contract Documents shall be acceptable to Owner, and its A. M. Best rating shall be indicated on the insurance certificates.

- A. Contractor shall maintain the following insurance coverage during the Work and for one year after Final Acceptance. Contractor shall also maintain the following insurance coverage during the performance of any corrective Work required by section 5.16.
 1. Commercial General Liability (CGL) on an Occurrence Form:
 - a. Completed operations/products liability;
 - b. Explosion, collapse, and underground; and
 - c. Employer's liability coverage.
 2. Automobile liability
- B. Contractor shall comply with the Washington State Industrial Insurance Act and, if applicable, the Federal Longshoremen's and Harbor Workers' Act and the Jones Act.
- C. All insurance coverages shall protect against claims for damages for personal and bodily injury or death, as well as claims for property damage, which may arise from operations in connection with the Work whether such operations are by Contractor or any Subcontractor.
- D. All insurance coverages shall be endorsed to include Owner as an additional named insured for Work performed in accordance with the Contract Documents, and all insurance certificates shall evidence the Owner as an additional insured.

GENERAL CONDITIONS FOR CONSTRUCTION AT WASHINGTON STATE PARKS

2.02 COVERAGE LIMITS INSURANCE COVERAGE CERTIFICATES

A. Insurance Coverage Certificates

The Contractor shall furnish acceptable proof of insurance coverage on the State of Washington Certificate of Insurance form SF500A dated 07/02/92 or an acceptable ACORD form.

B. Required Coverages

1. For a contract less than \$100,000.00, the coverage required is:

a. Public Liability Insurance – The Contractor shall at all times during the term of this contract, at its cost and expense, carry and maintain general public liability insurance, including contractual liability, against claims for bodily injury, personal injury, death or property damage occurring or arising out of services provided under this contract. This insurance shall cover claims caused by any act, omission, or negligence of the Contractor or its officers, agents, representatives, assigns or servants. The limits of liability insurance, which may be increased as deemed necessary by the contracting parties, shall be:

Each Occurrence	\$1,000,000.00
General Aggregate Limits (other than products – commercial operations)	\$1,000,000.00
Products – Commercial Operations Limit	\$1,000,000.00
Personal and Advertising Injury Limit	\$1,000,000.00
Fire Damage Limit (any one fire)	\$50,000.00
Medical Expense Limit (any one person)	\$5,000.00

b. If the contract is for underground utility work, then the Contractor shall provide proof of insurance for that above in the form of Explosion, Collapse and Underground (XCU) coverage.

c. Employers Liability on an occurrence basis in an amount not less than \$1,000,000.00 per occurrence.

2. For contracts over \$100,000.00 but less than \$5,000,000.00 the contractor shall obtain the coverage limits as listed for contracts below \$100,000.00 and General Aggregate and Products – Commercial Operations Limit of not less than \$2,000,000.00.

3. Coverage for Comprehensive General Bodily Injury Liability Insurance for a contract over \$5,000,000.00 is:

Each Occurrence	\$2,500,000.00
General Aggregate Limits (other than products – commercial operations)	\$5,000,000.00
Products – Commercial Operations limit	\$5,000,000.00
Personal and Advertising Injury Limit	\$2,500,000.00
Fire Damage Limit (any one fire)	\$50,000.00
Medical Expense Limit (any one Person)	\$5,000.00

4. For all Contracts – Automobile Liability: in the event that services delivered pursuant to this contract involve the use of vehicles or the transportation of clients, automobile liability insurance shall be required. If Contractor-owned personal vehicles are used, a Business Automobile Policy covering at a minimum Code 2 “owned autos only” must be secured. If Contractor employee’s vehicles are used, the Contractor must also include under the Business Automobile Policy Code 9, coverage for non-owned autos. The minimum limits for automobile liability is: \$1,000,000.00 per occurrence, using a combined single limit for bodily injury and property damage.

5. For Contracts for Hazardous Substance Removal (Asbestos Abatement, PCB Abatement, etc.)

a. In addition to providing insurance coverage for the project as outlined above, the Contractor shall provide Environmental Impairment Liability insurance for the hazardous substance removal as follows:

<u>EACH OCCURRENCE</u>	<u>AGGREGATE</u>
\$500,000.00	\$1,000,000.00

or \$1,000,000.00 each occurrence/aggregate bodily injury and property damage combined single limit.

GENERAL CONDITIONS FOR CONSTRUCTION AT WASHINGTON STATE PARKS

- 1) Insurance certificate must state that the insurer is covering hazardous substance removal.
- 2) Should this insurance be secured on a "claims made" basis, the coverage must be continuously maintained for one year following the project's "final completion" through official completion of the project, plus one year following.

For Contracts where hazardous substance removal is a subcomponent of contracted work, the general contractor shall provide to the Owner a certificate of insurance for coverage as defined in 5a. above. The State of Washington must be listed as an additional insured. This certificate of insurance must be provided to the Owner prior to commencing work.

2.03 INSURANCE COVERAGE CERTIFICATES

- A. Prior to commencement of the Work, Contractor shall furnish to Owner a completed certificate of insurance coverage.
- B. All insurance certificates shall name Owner's Project number and Project title.
- C. All insurance certificates shall specifically require 45 (forty-five) days prior notice to Owner of cancellation or any material change, except 30 (thirty) days for surplus line insurance.

2.04 PAYMENT AND PERFORMANCE BONDS

AIA Payment and Performance Bonds, form A312, or equivalent, is required by the Owner for the work of this contract. The forms shall be obtained from the Contractor's bonding company. The Payment Bond shall cover payment to laborers and mechanics, including payments to Employee Benefit Funds, and payments to subcontractors, material suppliers, and persons who shall supply such person or persons, or subcontractors with materials and supplies.

2.05 ALTERNATIVE SURETY

Contractor shall promptly furnish alternative security required to protect Owner and persons supplying labor or materials required by the Contract Documents if:

- A. Owner has a reasonable objection to the surety; or
- B. Any surety fails to furnish reports on its financial condition if requested by Owner.

2.06 BUILDER'S RISK

- A. Contractor shall purchase and maintain property insurance in the amount of the Contract Sum including all Change Orders for the Work on a replacement cost basis until Substantial Completion. The insurance shall cover the interest of Owner, Contractor, and any Subcontractors, as their interests may appear. For projects not involving New Building Construction, 'Installation Floater' is an acceptable substitute for the Builder's Risk Insurance.
- B. Contractor property insurance shall be placed on an "all risk" basis and insure against the perils of fire and extended coverage and physical loss or damage including theft, vandalism, malicious mischief, collapse, false work, temporary buildings, debris removal including demolition occasioned by enforcement of any applicable legal requirements, and shall cover reasonable compensation for A/E's services and expenses required as a result of an insured loss.
- C. Owner and Contractor waive all subrogation rights against each other, any Subcontractors, A/E, A/E's subconsultants, separate contractors described in section 5.20, if any, and any of their subcontractors, for damages caused by fire or other perils to the extent covered by property insurance obtained pursuant to this section or other property insurance applicable to the Work, except such rights as they have to proceeds of such insurance held by Owner as fiduciary. The policies shall provide such waivers of subrogation by endorsement or otherwise. A waiver of subrogation shall be effective to a person or entity even though that person or entity would otherwise have a duty of indemnification, contractual or otherwise, did not pay the insurance premium directly or indirectly, and whether or not the person or entity had an insurable interest in the property damaged.

GENERAL CONDITIONS FOR CONSTRUCTION AT WASHINGTON STATE PARKS

PART 3 - TIME AND SCHEDULE

3.01 PROGRESS AND COMPLETION

- A. Contractor shall diligently prosecute the Work, with adequate forces, achieve Substantial Completion within the Contract Time, and achieve Final Completion within 30 (thirty) calendar days thereafter, unless otherwise noted in Division 1 of the specifications.
- B. The Contractor shall notify the Engineer at least two (2) weekdays in advance if work is to be performed on a Saturday, Sunday, or legal holiday. No excavation work will be allowed on Saturdays, Sundays, or legal holidays unless specifically authorized by the Engineer.

3.02 CONSTRUCTION SCHEDULE

- A. Unless otherwise provided in Division 1, Contractor shall, within 14 (fourteen) calendar days after issuance of the Notice to Proceed, submit a preliminary Progress Schedule. The Progress Schedule shall show the sequence in which Contractor proposes to perform the Work, and the dates on which Contractor plans to start and finish major portions of the Work, including dates for shop drawings and other submittals, and for acquiring materials and equipment.
- B. The Progress Schedule shall be in the form of a Critical Path Method (CPM) logic network or, with the approval of the Owner, a bar chart schedule may be submitted. The scheduling of construction is the responsibility of the Contractor and is included in the contract to assure adequate planning and execution of the work. The schedule will be used to evaluate progress of the work for payment based on the Schedule of Values. The schedule shall show the Contractor's planned order and interdependence of activities, and sequence of work. As a minimum the schedule shall include:
 - 1. Date of Notice to Proceed;
 - 2. Activities (resources, durations, individual responsible for activity, early starts, late starts, early finishes, late finishes, etc.);
 - 3. Utility Shutdowns;
 - 4. Interrelationships and dependence of activities;
 - 5. Planned vs. actual status for each activity;
 - 6. Substantial completion;
 - 7. Punch list;
 - 8. Final inspection;
 - 9. Final completion, and
 - 10. Float time

The Schedule Duration shall be based on the Contract Time of Completion listed on the Bid Proposal form. The Owner shall not be obligated to accept any Early Completion Schedule suggested by the Contractor. The Contract Time for Completion shall establish the Schedule Completion Date.

If the Contractor feels that the work can be completed in less than the Specified Contract Time, then the Surplus Time shall be considered Project Float. This Float time shall be shown on the Project Schedule. It shall be available to accommodate changes in the work and unforeseen conditions.

Neither the Contractor nor the Owner have exclusive right to this Float Time. It belongs to the project.

- C. Owner shall return comments on the preliminary Progress Schedule to Contractor within 14 (fourteen) days of receipt. Review by Owner of Contractor's schedule does not constitute an approval or acceptance of Contractor's construction means, methods, or sequencing, or its ability to complete the Work within the Contract Time. Contractor shall revise and resubmit its schedule, as necessary. Owner may withhold a portion of progress payments until a Progress Schedule has been submitted which meets the requirements of this section.
- D. Contractor shall utilize and comply with the Progress Schedule. On a monthly basis, or as otherwise directed by Owner, Contractor shall submit an updated Progress Schedule at its own expense to Owner indicating actual progress. If, in the opinion of Owner, Contractor is not in conformance with the Progress Schedule for reasons other than acts of Force Majeure as identified in section 3.05, Contractor shall take

GENERAL CONDITIONS FOR CONSTRUCTION AT WASHINGTON STATE PARKS

such steps as are necessary to bring the actual completion dates of its work activities into conformance with the Progress Schedule, or revise the Progress Schedule to reconcile with the actual progress of the Work.

- E. Contractor shall promptly notify Owner in writing of any actual or anticipated event which is delaying or could delay achievement of any milestone or performance of any critical path activity of the Work. Contractor shall indicate the expected duration of the delay, the anticipated effect of the delay on the Progress Schedule, and the action being or to be taken to correct the problem. Provision of such notice does not relieve Contractor of its obligation to complete the Work within the Contract Time.

3.03 OWNER'S RIGHT TO SUSPEND THE WORK FOR CONVENIENCE

- A. Owner may, at its sole discretion, order Contractor, in writing, to suspend all or any part of the Work for up to 90 (ninety) days, or for such longer period as mutually agreed.
- B. Upon receipt of a written notice suspending the Work, Contractor shall immediately comply with its terms and take all reasonable steps to minimize the incurrence of cost of performance directly attributable to such suspension. Within a period up to 90 (ninety) days after the notice is delivered to Contractor, or within any extension of that period to which the parties shall have agreed, Owner shall either:
 - 1. Cancel the written notice suspending the Work; or
 - 2. Terminate the Work covered by the notice as provided in the termination provisions as more fully set forth in Part 9.
- C. If a written notice suspending the Work is cancelled or the period of the notice or any extension thereof expires, Contractor shall resume Work.
- D. Contractor shall be entitled to an equitable adjustment in the Contract Time, or Contract Sum, or both, for increases in the time or cost of performance directly attributable to such suspension, provided Contractor complies with all requirements set forth in Part 7.

3.04 OWNER'S RIGHT TO STOP THE WORK FOR CAUSE

- A. If Contractor fails or refuses to perform its obligations in accordance with the Contract Documents, Owner may order Contractor, in writing, to stop the Work, or any portion thereof, until satisfactory corrective action has been taken.
- B. Contractor shall not be entitled to an equitable adjustment in the Contract Time or Contract Sum for any increased cost or time of performance attributable to Contractor's failure or refusal to perform or from any reasonable remedial action taken by Owner based upon such failure.

3.05 DELAY

- A. Any delay in or failure of performance by Owner or Contractor, other than the payment of money, shall not constitute a default hereunder if and to the extent the cause for such delay or failure of performance was unforeseeable and beyond the control of the party ("Force Majeure"). Acts of Force Majeure include, but are not limited to:
 - 1. Acts of God or the public enemy;
 - 2. Acts or omissions of any government entity;
 - 3. Fire or other casualty for which Contractor is not responsible;
 - 4. Quarantine or epidemic;
 - 5. Strike or defensive lockout;
 - 6. Unusually severe weather, in excess of weather conditions which could not have been reasonably anticipated; and

GENERAL CONDITIONS FOR CONSTRUCTION AT WASHINGTON STATE PARKS

7. Unusual delay in receipt of supplies or products which were ordered and expedited and for which no substitute reasonably acceptable to Owner was available.
- B. Contractor shall be entitled to an equitable adjustment in the Contract Time for changes in the time of performance directly attributable to an act of Force Majeure, provided it makes a request for equitable adjustment according to section 7.03. Contractor shall not be entitled to an adjustment in the Contract Sum resulting from an act of Force Majeure.
- C. Contractor shall be entitled to an equitable adjustment in Contract Time, and may be entitled to an equitable adjustment in Contract Sum, if the cost or time of Contractor's performance is changed due to the fault or negligence of Owner, provided the Contractor makes a request according to sections 7.02 and 7.03.
- D. Contractor shall not be entitled to an adjustment in Contract Time or in the Contract Sum for any delay or failure of performance to the extent such delay or failure was caused by Contractor or anyone for whose acts Contractor is responsible.
- E. To the extent any delay or failure of performance was concurrently caused by the Owner and Contractor, Contractor shall be entitled to an adjustment in the Contract Time for that portion of the delay or failure of performance that was concurrently caused, provided it makes a request for equitable adjustment according to section 7.03, but shall not be entitled to an adjustment in Contract Sum.
- F. Contractor shall make all reasonable efforts to prevent and mitigate the effects of any delay, whether occasioned by an act of Force Majeure or otherwise.
- G. The Owner has acquired ownership and/or easement of lands for the construction, as indicated on the drawings, without cost to the Contractor. The Contractor understands and agrees that, should it appear at any time that the Owner has not acquired title to all of the right-of-ways and lands necessary for the performance of the work under the provisions of this contract, and that if any delay in the performance of said work occasioned by the failure of the Owner, its officers, or employees to acquire a title of any of said lands or right-of-way, such failure shall extend the contract completion date the number of days equal to the period of such delay. The Contractor waives any and all claims for damages against the Owner which the Contractor may sustain by reason of this delay in the work.

3.06 NOTICE TO OWNER OF LABOR DISPUTES

- A. If Contractor has knowledge that any actual or potential labor dispute is delaying or threatens to delay timely performance in accordance with the Contract Documents, Contractor shall immediately give notice, including all relevant information, to Owner.
- B. Contractor agrees to insert a provision in its Subcontracts and to require insertion in all sub-subcontracts, that in the event timely performance of any such contract is delayed or threatened by delay by any actual or potential labor dispute, the Subcontractor or Sub-subcontractor shall immediately notify the next higher tier Subcontractor or Contractor, as the case may be, of all relevant information concerning the dispute.

3.07 DAMAGES FOR FAILURE TO ACHIEVE TIMELY COMPLETION

- A. Liquidated Damages
 1. Timely performance and completion of the Work is essential to Owner and time limits stated in the Contract Documents are of the essence. Owner will incur serious and substantial damages if Substantial Completion of the Work does not occur within the Contract Time. However, it would be difficult if not impossible to determine the exact amount of such damages. Consequently, provisions for liquidated damages are included in the Contract Documents.
 2. The liquidated damage amounts set forth in the Contract Documents will be assessed not as a penalty, but as liquidated damages for breach of the Contract Documents. This amount is fixed and agreed upon by and between the Contractor and Owner because of the impracticability and extreme difficulty of fixing and ascertaining the actual damages the Owner would in such event sustain. This amount shall be construed as the actual amount of damages sustained by the Owner, and may be retained by the Owner and deducted from periodic payments to the Contractor.

GENERAL CONDITIONS FOR CONSTRUCTION AT WASHINGTON STATE PARKS

3. Assessment of liquidated damages shall not release Contractor from any further obligations or liabilities pursuant to the Contract Documents.

B. Actual Damages

Actual damages will be assessed for failure to achieve Final Completion within the time provided. Actual damages will be calculated on the basis of direct architectural, administrative, and other related costs attributable to the Project from the date when Final Completion should have been achieved, based on the date Substantial Completion is actually achieved, to the date Final Completion is actually achieved. Owner may offset these costs against any payment due Contractor.

PART 4 - SPECIFICATIONS, DRAWINGS, AND OTHER DOCUMENTS

4.01 DISCREPANCIES AND CONTRACT DOCUMENT REVIEW

- A. The intent of the Specifications and Drawings is to describe a complete Project to be constructed in accordance with the Contract Documents. Contractor shall furnish all labor, materials, equipment, tools, transportation, permits, and supplies, and perform the Work required in accordance with the Drawings, Specifications, and other provisions of the Contract Documents.
- B. The Contract Documents are complementary. What is required by one part of the Contract Documents shall be binding as if required by all. Anything mentioned in the Specifications and not shown on the Drawings, or shown on the Drawings and not mentioned in the Specifications, shall be of like effect as if shown or mentioned in both.
- C. Contractor shall carefully study and compare the Contract Documents with each other and with information furnished by Owner. If, during the performance of the Work, Contractor finds a conflict, error, inconsistency, or omission in the Contract Documents, it shall promptly and before proceeding with the Work affected thereby, report such conflict, error, inconsistency, or omission to A/E in writing.
- D. Contractor shall do no Work without applicable Drawings, Specifications, or written modifications, or Shop Drawings where required, unless instructed to do so in writing by Owner. If Contractor performs any construction activity, and it knows or reasonably should have known that any of the Contract Documents contain a conflict, error, inconsistency, or omission, Contractor shall be responsible for the performance and shall bear the cost for its correction.
- E. Contractor shall provide any work or materials the provision of which is clearly implied and is within the scope of the Contract Documents even if the Contract Documents do not mention them specifically.
- F. Questions regarding interpretation of the requirements of the Contract Documents shall be referred to the A/E.

4.02 PROJECT RECORD

- A. Contractor shall legibly mark in ink on a separate set of the Drawings and Specifications all actual construction, including depths of foundations, horizontal and vertical locations of internal and underground utilities and appurtenances referenced to permanent visible and accessible surface improvements, field changes of dimensions and details, actual suppliers, manufacturers and trade names, models of installed equipment, and Change Order Proposals (COP). This separate set of Drawings and Specifications shall be the "Project Record."
- B. The Project Record shall be maintained on the project site throughout the construction and shall be clearly labeled "PROJECT RECORD". The Project Record shall be updated at least weekly noting all changes and shall be available to Owner at all times.
- C. Contractor shall submit the completed and finalized Project Record to A/E prior to Final Acceptance.

4.03 SUBMITTALS

- A. "Submittals" means documents and other information required to be submitted to A/E by Contractor pursuant to the Contract Documents, showing in detail: the proposed fabrication and assembly of structural

GENERAL CONDITIONS FOR CONSTRUCTION AT WASHINGTON STATE PARKS

elements; and the installation (i.e. form, fit, and attachment details) of materials and equipment. Submittals include, but are not limited to, drawings, diagrams, layouts, schematics, descriptive literature, illustrations, schedules, performance and test data, samples, and similar materials furnished by Contractor to explain in detail specific portions of the Work required by the Contract Documents. For materials and equipment to be incorporated into the Work, Contractor submittal shall include the name of the manufacturer, the model number, and other information concerning the performance, capacity, nature, and rating of the item. When directed, Contractor shall submit all samples at its own expense. Owner may duplicate, use, and disclose Submittals provided in accordance with the Contract Documents.

- B. Contractor shall coordinate all Shop Drawings, and review them for accuracy, completeness, and compliance with the Contract Documents and shall indicate its approval thereon as evidence of such coordination and review. Where required by law, Shop Drawings shall be stamped by an appropriate professional licensed by the state of Washington. Shop Drawings submitted to A/E without evidence of Contractor's approval shall be returned for resubmission. Contractor shall review, approve, and submit Shop Drawings with reasonable promptness and in such sequence as to cause no delay in the Work or in the activities of Owner or separate contractors. Contractor's submittal schedule shall allow a reasonable time for A/E review. A/E will review, approve, or take other appropriate action on the Shop Drawings. Contractor shall perform no portion of the Work requiring submittal and review of Shop Drawings until the respective submittal has been reviewed and the A/E has approved or taken other appropriate action. Owner and A/E shall respond to Shop Drawing submittals with reasonable promptness. Any Work by Contractor shall be in accordance with reviewed Shop Drawings. Submittals made by Contractor which are not required by the Contract Documents may be returned without action.
- C. Approval, or other appropriate action with regard to Submittals, by Owner or A/E shall not relieve Contractor of responsibility for any errors or omissions in such Submittals, nor from responsibility for compliance with the requirements of the Contract Documents. Unless specified in the Contract Documents, review by Owner or A/E shall not constitute an approval of the safety precautions employed by Contractor during construction, or constitute an approval of Contractor's means or methods of construction. If Contractor fails to obtain approval before installation and the item or work is subsequently rejected, Contractor shall be responsible for all costs of correction.
- D. If Shop Drawings show variations from the requirements of the Contract Documents, Contractor shall describe such variations in writing, separate from the Shop Drawings, at the time it submits the Shop Drawings containing such variations. If A/E approves any such variation, an appropriate Change Order will be issued. If the variation is minor and does not involve an adjustment in the Contract Sum or Contract Time, a Change Order need not be issued; however, the modification shall be recorded upon the Project Record.
- E. Unless otherwise provided in Division I, Contractor shall submit to A/E for approval 5 (five) copies of all Submittals. Unless otherwise indicated, 3 (three) sets of all Submittals shall be retained by A/E and 2 (two) sets shall be returned to Contractor.

4.04 ORGANIZATION OF SPECIFICATIONS

Specifications are prepared in sections which conform generally with trade practices. These sections are for Owner and Contractor convenience and shall not control Contractor in dividing the Work among the Subcontractors or in establishing the extent of the Work to be performed by any trade.

4.05 OWNERSHIP AND USE OF DRAWINGS, SPECIFICATIONS, AND OTHER DOCUMENTS

- A. The Drawings, Specifications, and other documents prepared by A/E are instruments of A/E's service through which the Work to be executed by Contractor is described. Neither Contractor nor any Subcontractor shall own or claim a copyright in the Drawings, Specifications, and other documents prepared by A/E, and A/E shall be deemed the author of them and will, along with any rights of Owner, retain all common law, statutory, and other reserved rights, in addition to the copyright. All copies of these documents, except Contractor's set, shall be returned or suitably accounted for to A/E, on request, upon completion of the Work.
- B. The Drawings, Specifications, and other documents prepared by the A/E, and copies thereof furnished to Contractor, are for use solely with respect to this Project. They are not to be used by Contractor or any

GENERAL CONDITIONS FOR CONSTRUCTION AT WASHINGTON STATE PARKS

Subcontractor on other projects or for additions to this Project outside the scope of the Work without the specific written consent of Owner and A/E. Contractor and Subcontractors are granted a limited license to use and reproduce applicable portions of the Drawings, Specifications, and other documents prepared by A/E appropriate to and for use in the execution of their Work.

- C. Contractor and all Subcontractors grant a non-exclusive license to Owner, without additional cost or royalty, to use for its own purposes (including reproduction) all Shop Drawings, together with the information and diagrams contained therein, prepared by Contractor or any Subcontractor. In providing Shop Drawings, Contractor and all Subcontractors warrant that they have authority to grant to Owner a license to use the Shop Drawings, and that such license is not in violation of any copyright or other intellectual property right. Contractor agrees to defend and indemnify Owner pursuant to the indemnity provisions in section 5.03 and 5.23 from any violations of copyright or other intellectual property rights arising out of Owner's use of the Shop Drawings hereunder, or to secure for Owner, at Contractor's own cost, licenses in conformity with this section.
- D. The Shop Drawings and other submittals prepared by Contractor, Subcontractors of any tier, or its or their equipment or material suppliers, and copies thereof furnished to Contractor, are for use solely with respect to this Project. They are not to be used by Contractor or any Subcontractor of any tier, or material or equipment supplier, on other projects or for additions to this Project outside the scope of the Work without the specific written consent of Owner. The Contractor, Subcontractors of any tier, and material or equipment suppliers are granted a limited license to use and reproduce applicable portions of the Shop Drawings and other submittals appropriate to and for use in the execution of their Work under the Contract Documents.

PART 5 - PERFORMANCE

5.01 CONTRACTOR CONTROL AND SUPERVISION

- A. Contractor shall supervise and direct the Work, using its best skill and attention, and shall perform the Work in a skillful manner. Contractor shall be solely responsible for and have control over construction means, methods, techniques, sequences, and procedures and for coordinating all portions of the Work, unless the Contract Documents give other specific instructions concerning these matters. Contractor shall disclose its means and methods of construction when requested by Owner.
- B. Performance of the Work shall be directly supervised by a competent superintendent who is satisfactory to Owner and has authority to act for Contractor. The superintendent shall not be changed without the prior written consent of Owner. Owner may require Contractor to remove the superintendent from the Work or Project site, if Owner reasonably deems the superintendent incompetent, careless, or otherwise objectionable, provided Owner has first notified Contractor in writing and allowed a reasonable period for transition. The superintendent shall be on-site at all times while the Work is being performed, unless approved in writing by owner, in advance.
- C. Contractor shall be responsible to Owner for acts and omissions of Contractor, Subcontractors, and their employees and agents.
- D. Contractor shall enforce strict discipline and good order among Contractor's employees and other persons performing the Work. Contractor shall not permit employment of persons not skilled in tasks assigned to them. Contractor's employees shall at all times conduct business in a manner which assures fair, equal, and nondiscriminatory treatment of all persons. Owner may, by written notice, request Contractor to remove from the Work or Project site any employee Owner reasonably deems incompetent, careless, or otherwise objectionable.
- E. Contractor shall, at all times, keep on the Project site a copy of the Drawings, Specifications, addenda, reviewed Shop Drawings, permits, and permit drawings.
- F. Contractor shall ensure that its owner(s) and employees, and those of its Subcontractors, comply with the Ethics in Public Service Act RCW 42.52, which, among other things, prohibits state employees from having an economic interest in any public works contract that was made by, or supervised by, that employee. Contractor shall remove, at its sole cost and expense, any of its, or its Subcontractors', employees, if they are in violation of this act.

GENERAL CONDITIONS FOR CONSTRUCTION AT WASHINGTON STATE PARKS

5.02 PERMITS, FEES, AND NOTICES

- A. The Owner has obtained a Shorelines Substantial Development Permit and/or other environmental permits as required for this project. The permits with provisions which affect the construction methods or schedule have been incorporated into these specifications. The Contractor shall abide by all restrictions noted in these permits as the construction is in progress.
- B. All other permits or fees required by local, state or federal governmental agencies necessary for the construction of this project shall be obtained and paid by the Contractor. Only the cost for the building permit will be reimbursed by the Owner.
- C. The Contractor shall conform to all local, State and National Codes in all phases of this project. Where conflicts arise between plans, specifications and code requirements, the code shall prevail unless the plans or specifications are more stringent.

5.03 PATENTS AND ROYALTIES

Contractor is responsible for, and shall pay, all royalties and license fees. Contractor shall defend, indemnify, and hold Owner harmless from any costs, expenses, and liabilities arising out of the infringement by Contractor of any patent, copyright, or other intellectual property right used in the Work; however, provided that Contractor gives prompt notice, Contractor shall not be responsible for such defense or indemnity when a particular design, process, or product of a particular manufacturer or manufacturers is required by the Contract Documents. If Contractor has reason to believe that use of the required design, process, or product constitutes an infringement of a patent or copyright, it shall promptly notify Owner of such potential infringement.

5.04 PREVAILING WAGES

- A. Contractor and all subcontractors shall pay the prevailing rate of wages to all workers, laborers, or mechanics employed in the performance of any part of the Work in accordance with RCW 39.12 and the rules and regulations of the Department of Labor and Industries. The schedule of prevailing wage rates for the locality or localities of the Work is determined by the Industrial Statistician of the Department of Labor and Industries. It is the Contractor's responsibility to verify the applicable prevailing wage rate.
- B. Before payment is made by the Owner to the Contractor for any work performed by the Contractor and subcontractors whose work is included in the application for payment, the Contractor shall submit, or shall have previously submitted to the Owner for the Project, a Statement of Intent to Pay Prevailing Wages, approved by the Department of Labor and Industries, certifying the rate of hourly wage paid and to be paid each classification of laborers, workers, or mechanics employed upon the Work by Contractor and Subcontractors. Such rates of hourly wage shall not be less than the prevailing wage rate.
- C. Prior to release of retainage, the Contractor shall submit to the Owner an Affidavit of Wages Paid, approved by the Department of Labor and Industries, for the Contractor and every subcontractor, of any tier, that performed work on the Project.
- D. Disputes regarding prevailing wage rates shall be referred for arbitration to the Director of the Department of Labor and Industries. The arbitration decision shall be final and conclusive and binding on all parties involved in the dispute as provided for by RCW 39.12.060.
- E. Each Application for Payment submitted by Contractor shall state that prevailing wages have been paid in accordance with the prefled statement(s) of intent, as approved. Copies of the approved intent statement(s) shall be posted on the job site with the address and telephone number of the Industrial Statistician of the Department of Labor and Industries where a complaint or inquiry concerning prevailing wages may be made.
- F. In compliance with chapter 296-127 WAC, Contractor shall pay to the Department of Labor and Industries the currently established fee(s) for each statement of intent and/or affidavit of wages paid submitted to the Department of Labor and Industries for certification.
- G. Copies of approved Intents to Pay Prevailing Wages for the Contractor and all subcontractors shall be submitted with the Contractor's first application for payment. As additional subcontractors perform work on

GENERAL CONDITIONS FOR CONSTRUCTION AT WASHINGTON STATE PARKS

the project, their approved Intent forms shall be submitted with the Contractor's next application for payment.

- H. The Contractor or subcontractor directly contracting for "Off-Site, Prefabricated, Non-Standard, Project Specific Items" shall identify and report information required on the affidavit of wages paid form filed with the Department of Labor and Industries. The Contractor shall include language in its subcontracts requiring subcontractors and lower-tier subcontractors to comply with the reporting requirements for "Off-Site, Prefabricated, Non-Standard, Project Specific Item(s)" on the affidavit of wages paid.

The reporting requirement for Items shall apply for all public works contracts estimated to cost over \$1 million entered into by the Owner and Contractor between September 1, 2010 and December 31, 2013.

"Off-site, prefabricated, nonstandard, project specific item(s)" means products or items that are:

1. Made primarily of architectural or structural precast concrete, fabricated steel, pipe and pipe systems, or sheet metal and sheet metal duct work;
2. Produced specifically for the public work and not considered to be regularly available shelf items;
3. Produced or manufactured by labor expended to assemble or modify standard items; and
4. Produced at an off-site location outside Washington.

The Contractor or subcontractor shall comply with the reporting requirements and instructions on the affidavit of wages paid form, and shall report the following information on the affidavit of wages paid form submitted to the Department of Labor and Industries in order to comply with the reporting requirements for use of "Off-Site, Prefabricated, Non-Standard, Project Specific item(s)":

1. The estimated cost of the public works project;
2. The name of the awarding agency and the project title;
3. The contract value of the off-site, prefabricated, nonstandard, project specific item(s) produced outside of Washington State, including labor and materials; and
4. The name, address, and federal employer identification number of the contractor that produced the off-site, prefabricated, nonstandard, project specific item(s).

The owner may direct the contractor, at no additional cost to the owner, to remove and substitute any subcontractor(s) found to be out of compliance with the "Off-Site Prefabricated Non-Standard Project Specific Item(s)" reporting requirements more than one time as determined by the Department of Labor and Industries.

- I. The Contractor and all subcontractors shall promptly submit to the Owner certified payroll copies if requested.

5.05 HOURS OF LABOR

- A. Contractor shall comply with all applicable provisions of RCW 49.28 and they are incorporated herein by reference. Pursuant to that statute, no laborer, worker, or mechanic employed by Contractor, any Subcontractor, or any other person performing or contracting to do the whole or any part of the Work, shall be permitted or required to work more than eight (8) hours in any one calendar day, provided, that in cases of extraordinary emergency, such as danger to life or property, the hours of work may be extended, but in such cases the rate of pay for time employed in excess of eight (8) hours of each calendar day shall be not less than one and one-half times (x1.5) the rate allowed for this same amount of time during eight (8) hours service.
- B. Notwithstanding the preceding paragraph, RCW 49.28 permits a contractor or subcontractor in any public works contract subject to those provisions, to enter into an agreement with its employees in which the employees work up to ten (10) hours in a calendar day. No such agreement may provide that the employees work ten-hour days for more than four (4) calendar days a week. Any such agreement is subject to approval by the employees. The overtime provisions of RCW 49.28 shall not apply to the hours, up to forty (40) hours per week, worked pursuant to any such agreement.

5.06 NONDISCRIMINATION

- A. Discrimination in all phases of employment is prohibited by, among other laws and regulations, Title VII of the Civil Rights Act of 1964, the Vietnam Era Veterans Readjustment Act of 1974, sections 503 and 504 of the Vocational Rehabilitation Act of 1973, the Equal Employment Act of 1972, the Age Discrimination Act of

GENERAL CONDITIONS FOR CONSTRUCTION AT WASHINGTON STATE PARKS

1967, the Americans with Disabilities Act of 1990, the Civil Rights Act of 1991, Presidential Executive Order 11246, Executive Order 11375, the Washington State Law Against Discrimination, RCW 49.60, and Gubernatorial Executive Order 85-09. These laws and regulations establish minimum requirements for affirmative action and fair employment practices which Contractor must meet.

- B. During performance of the Work:
1. Contractor shall not discriminate against any employee or applicant for employment because of race, creed, color, national origin, sex, age, marital status, or the presence of any physical, sensory, or mental disability, Vietnam era veteran status, or disabled veteran status, nor commit any other unfair practices as defined in RCW 49.60.
 2. Contractor shall, in all solicitations or advertisements for employees placed by or for it, state that the contractor is an "equal opportunity employer".
 3. Contractor shall send to each labor union, employment agency, or representative of workers with which it has a collective bargaining agreement or other contract or understanding, a notice advising the labor union, employment agency, or workers' representative of Contractor's obligations according to the Contract Documents and RCW 49.60.
 4. Contractor shall permit access to its books, records, and accounts, and to its premises by Owner, and by the Washington State Human Rights Commission, for the purpose of investigation to ascertain compliance with this section of the Contract Documents.
 5. Contractor shall include the provisions of this section in every Subcontract.
- C. Nondiscrimination Requirement. During the term of this Contract, Contractor, including any subcontractor, shall not discriminate on the bases enumerated at RCW 49.60.530(3). In addition, Contractor, including any subcontractor, shall give written notice of this nondiscrimination requirement to any labor organizations with which Contractor, or subcontractor, has a collective bargaining or other agreement.
- D. Obligation to Cooperate. Contractor, including any subcontractor, shall cooperate and comply with any Washington state agency investigation regarding any allegation that Contractor, including any subcontractor, has engaged in discrimination prohibited by this Contract pursuant to RCW 49.60.530(3).
- E. Default. Notwithstanding any provision to the contrary, Owner may suspend Contractor, including any subcontractor, upon notice of a failure to participate and cooperate with any state agency investigation into alleged discrimination prohibited by this Contract, pursuant to RCW 49.60.530(3). Any such suspension will remain in place until Owner receives notification that Contractor, including any subcontractor, is cooperating with the investigating state agency. In the event Contractor, or subcontractor, is determined to have engaged in discrimination identified at RCW 49.60.530(3), Owner may terminate this Contract in whole or in part, and Contractor, subcontractor, or both, may be referred for debarment as provided in RCW 39.26.200. Contractor or subcontractor may be given a reasonable time in which to cure this noncompliance, including implementing conditions consistent with any court-ordered injunctive relief or settlement agreement.
- F. Remedies for Breach. Notwithstanding any provision to the contrary, in the event of Contract termination or suspension for engaging in discrimination, Contractor, subcontractor, or both, shall be liable for contract damages as authorized by law including, but not limited to, any cost difference between the original contract and the replacement or cover contract and all administrative costs directly related to the replacement contract, which damages are distinct from any penalties imposed under Chapter 49.60, RCW. Owner shall have the right to deduct from any monies due to Contractor or subcontractor, or that thereafter become due, an amount for damages Contractor or subcontractor will owe Owner for default under this provision.

5.07 SAFETY PRECAUTIONS

- A. In performing this contract, the Contractor shall provide for protecting the lives and health of employees and other persons; preventing damage to property, materials, supplies, and equipment; and avoid work interruptions. For these purposes, the Contractor shall:

GENERAL CONDITIONS FOR CONSTRUCTION AT WASHINGTON STATE PARKS

1. Follow Washington Industrial Safety and Health Act (WISHA) regional directives and provide a site-specific safety program that will require an accident prevention and hazard analysis plan for the contractor and each subcontractor on the work site. The Contractor shall submit a site-specific safety plan to the Owner's representative prior to the initial scheduled construction meeting.
 2. Provide adequate safety devices and measures including, but not limited to, the appropriate safety literature, notice, training, permits, placement and use of barricades, signs, signal lights, ladders, scaffolding, staging, runways, hoist, construction elevators, shoring, temporary lighting, grounded outlets, wiring, hazardous materials, vehicles, construction processes, and equipment required by Chapter 19.27 RCW, State Building Code (International Building, Electrical, Mechanical, Fire, and Uniform Plumbing Codes); Chapter 212-12 WAC, Fire Marshal Standards, Chapter 49.17 RCW, WISHA; Chapter 296-155 WAC, Safety Standards for Construction Work; Chapter 296-65 WAC; WISHA Asbestos Standard; WAC 296-62-071, Respirator Standard; WAC 296-62, General Occupation Health Standards, WAC 296-24, General Safety and Health Standards, WAC 296-24, General Safety and Health Standards, Chapter 49.70 RCW, and Right to Know Act.
 3. Comply with the State Environmental Policy Act (SEPA), Clean Air Act, Shoreline Management Act, and other applicable federal, state, and local statutes and regulations dealing with the prevention of environmental pollution and the preservation of public natural resources.
 4. Post all permits, notices, and/or approvals in a conspicuous location at the construction site.
 5. Provide any additional measures that the Owner determines to be reasonable and necessary for ensuring a safe environment in areas open to the public. Nothing in this part shall be construed as imposing a duty upon the Owner or A/E to prescribe safety conditions relating to employees, public, or agents of the Contractors.
 6. The Contractor shall make available a list of hazardous products being used on the project, and their respective Material Safety Data Sheets (MSDS) to the Engineer. This information will be required at the pre-construction conference.
- B. In carrying out its responsibilities according to the Contract Documents, Contractor shall protect the lives and health of employees performing the Work and other persons who may be affected by the Work; prevent damage to materials, supplies, and equipment whether on site or stored off-site; and prevent damage to other property at the site or adjacent thereto. Contractor shall comply with all applicable laws, ordinances, rules, regulations, and orders of any public body having jurisdiction for the safety of persons or property or to protect them from damage, injury, or loss; shall erect and maintain all necessary safeguards for such safety and protection; and shall notify owners of adjacent property and utilities when prosecution of the Work may affect them.
- C. Contractor shall maintain an accurate record of exposure data on all incidents relating to the Work resulting in death, traumatic injury, occupational disease, or damage to property, materials, supplies, or equipment. Contractor shall immediately report any such incident to Owner. Owner shall, at all times, have a right of access to all records of exposure.
- D. Contractor shall provide all persons working on the Project site with information and training on hazardous chemicals in their work at the time of their initial assignment, and whenever a new hazard is introduced into their work area.
1. Information. At a minimum, Contractor shall inform persons working on the Project site of:
 - a. The requirements of chapter 296-62 WAC, General Occupational Health Standards;
 - b. Any operations in their work area where hazardous chemicals are present; and
 - c. The location and availability of written hazard communication programs, including the required list(s) of hazardous chemicals and material safety data sheets required by chapter 296-62 WAC.
 2. Training. At a minimum, Contractor shall provide training for persons working on the Project site which includes:

GENERAL CONDITIONS FOR CONSTRUCTION AT WASHINGTON STATE PARKS

- a. Methods and observations that may be used to detect the presence or release of a hazardous chemical in the work area (such as monitoring conducted by the employer, continuous monitoring devices, visual appearance or odor of hazardous chemicals when being released, etc.);
 - b. The physical and health hazards of the chemicals in the work area;
 - c. The measures such persons can take to protect themselves from these hazards, including specific procedures Contractor, or its Subcontractors, or others have implemented to protect those on the Project site from exposure to hazardous chemicals, such as appropriate work practices, emergency procedures, and personal protective equipment to be used; and
 - d. The details of the hazard communications program developed by Contractor, or its Subcontractors, including an explanation of the labeling system and the material safety data sheet, and how employees can obtain and use the appropriate hazard information.
- E. Contractor's responsibility for hazardous, toxic, or harmful substances shall include the following duties:
1. Contractor shall not keep, use, dispose, transport, generate, or sell on or about the Project site, any substances now or hereafter designated as, or which are subject to regulation as, hazardous, toxic, dangerous, or harmful by any federal, state or local law, regulation, statute or ordinance (hereinafter collectively referred to as "hazardous substances", in violation of any such law, regulation, statute, or ordinance, but in no case shall any such hazardous substance be stored more than 90 days on the Project site.
 2. Contractor shall promptly notify Owner of all spills or releases of any hazardous substances which are otherwise required to be reported to any regulatory agency and pay the cost of cleanup. Contractor shall promptly notify Owner of all failures to comply with any federal, state, or local law, regulation, or ordinance; all inspections of the Project site by any regulatory entity concerning the same; all regulatory orders or fines; and all responses or interim cleanup actions taken by or proposed to be taken by any government entity or private party on the Project site.
- F. All Work shall be performed with due regard for the safety of the public. Contractor shall perform the Work so as to cause a minimum of interruption of vehicular traffic or inconvenience to pedestrians. All arrangements to care for such traffic shall be Contractor's responsibilities. All expenses involved in the maintenance of traffic by way of detours shall be borne by Contractor.
- G. In an emergency affecting the safety of life or the Work or of adjoining property, Contractor is permitted to act, at its discretion, to prevent such threatened loss or injury, and Contractor shall so act if so authorized or instructed.
- H. Nothing provided in this section shall be construed as imposing any duty upon Owner or A/E with regard to, or as constituting any express or implied assumption of control or responsibility over, Project site safety, or over any other safety conditions relating to employees or agents of Contractor or any of its Subcontractors, or the public.

5.08 OPERATIONS, MATERIAL HANDLING, AND STORAGE AREAS

- A. Contractor shall confine all operations, including storage of materials, to Owner-approved areas.
- B. Temporary buildings (e.g., storage sheds, shops, offices) and utilities may be provided by Contractor only with the consent of Owner and without expense to Owner. The temporary buildings and utilities shall remain the property of Contractor and shall be removed by Contractor at its expense upon completion of the Work.
- C. Contractor shall use only established roadways or temporary roadways authorized by Owner. When materials are transported in prosecuting the Work, vehicles shall not be loaded beyond the loading capacity recommended by the manufacturer of the vehicle or prescribed by federal, state, or local law or regulation.
- D. Ownership and control of all materials or facility components to be demolished or removed from the Project site by Contractor shall immediately vest in Contractor upon severance of the component from the facility or severance of the material from the Project site. Contractor shall be responsible for compliance with all

GENERAL CONDITIONS FOR CONSTRUCTION AT WASHINGTON STATE PARKS

laws governing the storage and ultimate disposal. Contractor shall provide Owner with a copy of all manifests and receipts evidencing proper disposal when required by Owner or applicable law.

- E. Contractor shall be responsible for the proper care and protection of its materials and equipment delivered to the Project site. Materials and equipment may be stored on the premises subject to approval of Owner. When Contractor uses any portion of the Project site as a shop, Contractor shall be responsible for any repairs, patching, or cleaning arising from such use.
- F. Contractor shall protect and be responsible for any damage or loss to the Work, or to the materials or equipment until the date of Substantial Completion, and shall repair or replace without cost to Owner any damage or loss that may occur, except damages or loss caused by the acts or omissions of Owner. Contractor shall also protect and be responsible for any damage or loss to the Work, or to the materials or equipment, after the date of Substantial Completion, and shall repair or replace without cost to Owner any such damage or loss that might occur, to the extent such damages or loss are caused by the acts or omissions of Contractor, or any Subcontractor.
- G. Any removed item shall be salvaged without undue damage and stockpiled in a neat and orderly fashion in an area designated by the Engineer. All removed items shall remain the property of the Owner, unless, due to their condition, they are rejected by the Engineer. All materials of whatever nature that are rejected shall be properly disposed by the Contractor in compliance with all laws and regulations.
- H. If designated campsites or emergency overflow areas are approved for use, the Contractor shall comply with all campground rules and regulations of the Washington State Parks and Recreation Commission and the park manager.

5.09 PRIOR NOTICE OF EXCAVATION

- A. "Excavation" means an operation in which earth, rock, or other material on or below the ground is moved or otherwise displaced by any means, except the tilling of soil less than 12 (twelve) inches in depth for agricultural purposes, or road ditch maintenance that does not change the original road grade or ditch flow line. Before commencing any excavation, Contractor shall provide notice of the scheduled commencement of excavation to all owners of underground facilities or utilities, through locator services.

5.10 UNFORESEEN PHYSICAL CONDITIONS

- A. If Contractor encounters conditions at the site which are subsurface or otherwise concealed physical conditions which differ materially from those indicated in the Contract Documents, or unknown physical conditions of an unusual nature which differ materially from those ordinarily found to exist and generally recognized as inherent in construction activities of the character provided for in the Contract Documents, then Contractor shall give written notice to Owner promptly and in no event later than 7 (seven) days after the first observance of the conditions. Conditions shall not be disturbed prior to such notice.
- B. If such conditions differ materially and cause a change in Contractor's cost of, or time required for, performance of any part of the Work, the Contractor may be entitled to an equitable adjustment in the Contract Time or Contract Sum, or both, provided it makes a request therefore as provided in part 7.

5.11 PROTECTION OF EXISTING STRUCTURES, EQUIPMENT, VEGETATION, UTILITIES, AND IMPROVEMENTS

- A. Contractor shall protect from damage all existing structures, equipment, improvements, utilities, and vegetation: at or near the Project site; and on adjacent property of a third party, the locations of which are made known to or should be known by Contractor. Contractor shall repair any damage, including that to the property of a third party, resulting from failure to comply with the requirements of the Contract Documents or failure to exercise reasonable care in performing the Work. If Contractor fails or refuses to repair the damage promptly, Owner may have the necessary work performed and charge the cost to Contractor.
- B. Contractor shall only remove trees when specifically authorized to do so, and shall protect vegetation that will remain in place.
- C. In general, the locations of existing major utilities and equipment, whether above ground or underground, are indicated on the drawings. This information has been obtained from utility maps and verbal

GENERAL CONDITIONS FOR CONSTRUCTION AT WASHINGTON STATE PARKS

descriptions. The Engineer does not guarantee the accuracy or completeness of this information. Other above ground or underground facilities not shown on the drawings may be encountered during the course of the work for which the Contractor is fully responsible to properly locate and identify within the construction area.

- D. Existing above ground and underground facilities and appurtenant structures, which includes but is not limited to, power transmission and distribution, telephone, alarm systems, sanitary sewers, gas services, water service and house or yard drains and fences, shall be located, protected, maintained, relocated, rerouted, removed and restored as may be necessary by the Contractor for completion of the work, but in a manner satisfactory to their respective owners and operators of the services and to the Engineer with the least possible interruption to existing services.
- E. The Contractor shall be responsible for location and maintenance of existing utilities and improvements. Under no circumstances will errors or omissions in location of utilities or improvements, whether they be visible from the surface, buried, or otherwise obscured, be considered as a basis for a claim for additional compensation by the Contractor.
- F. All utilities shall be protected and maintained in continuous operation except where special arrangements have been made with the appropriate utility owner. All damaged utilities shall be restored to original condition, subject to the approval of its owner and at the Contractor's own expense.
- G. If requested, the Contractor shall provide record information about locations, depths, and dimensions of lines, appurtenances, and structures, and any other relevant information about electrical power, water, sewer, and other utilities.
- H. The Contractor shall provide the Engineer with the data required to make a detailed set of record plans. This data will be obtained and recorded by the Contractor during construction on plans supplied by the Engineer. The Contractor shall ensure that the data is obtained. Typical information to be gathered includes the locations of:
 - 1. Buried utilities
 - 2. Junctions of sewer wyes
 - 3. Junctions of electrical taps
 - 4. Clean-outs
 - 5. Deflection points of utilities
 - 6. Valves
- I. Procedure for obtaining this information will be developed by the Engineer working with the Contractor.
- J. Contractor shall protect all existing facilities using whatever methods are necessary, subject to the Engineer's approval. Trees, shrubs, vegetation, or lawn shall not be damaged, scarred, or destroyed unless deemed necessary for work on this contract. All trees damaged during construction shall be immediately repaired using SEAL AND HEAL or other materials as directed by the Engineer. Any damage to the above-mentioned items shall be repaired at the Contractor's expense and to the Engineer's satisfaction.
- K. In the event that archaeological resources are found or unearthed on public land during the performance of this contract, the Contractor shall be required to comply with RCW 27.44 and RCW 27.53 and the rules and regulations of the office of Archaeology and Historic Preservation, including compliance with all archaeological excavation permit requirements.

5.12 LAYOUT OF WORK

- A. Contractor shall plan and lay out the Work in advance of operations so as to coordinate all work without delay or revision.
- B. Contractor shall lay out the Work from Owner-established baselines and bench marks indicated on the Drawings, and shall be responsible for all field measurements in connection with the layout. Contractor shall furnish, at its own expense, all stakes, templates, platforms, equipment, tools, materials, and labor required to lay out any part of the Work. Contractor shall be responsible for executing the Work to the lines

GENERAL CONDITIONS FOR CONSTRUCTION AT WASHINGTON STATE PARKS

and grades that may be established. Contractor shall be responsible for maintaining or restoring all stakes and other marks established.

- C. The indicated limits of work shall be the controlling factor in the Contractor's scope of operation and no payment shall be due for work done out of the limits. Damage to areas not in the Contractor's work area shall be repaired at the Contractor's expense. Questions of what constitutes the work area shall be determined by the Engineer. Only the best methods of construction will be allowed.
- D. The Engineer may adjust or relocate any portion of the system to meet site requirements or to improve the system without additional compensation to the Contractor, provided such adjustments do not represent appreciable costs for additional labor and materials.

5.13 MATERIAL AND EQUIPMENT

- A. All equipment, material, and articles incorporated into the Work shall be new and of the most suitable grade for the purpose intended, unless otherwise specifically provided in the Contract Documents. References in the Specifications to equipment, material, articles, or patented processes by trade name, make, or catalog number, shall be regarded as establishing a standard quality and shall not be construed as limiting competition. Contractor may, at its option, use any equipment, material, article, or process that, in the judgment of A/E, is equal to that named in the specifications, unless otherwise specifically provided in the Contract Documents.
- B. Contractor shall do all cutting, fitting, or patching that may be required to make its several parts fit together properly, or receive or be received by work of others set forth in, or reasonably implied by, the Contract Documents. Contractor shall not endanger any work by cutting, excavating, or otherwise altering the Work and shall not cut or alter the work of any other contractor unless approved in advance by Owner.
- C. Should any of the Work be found defective, or in any way not in accordance with the Contract Documents, this work, in whatever stage of completion, may be rejected by Owner.
- D. The Contractor shall furnish proof of equality in all respects to the specified items when proposing alternate brands or materials. Any significant deviations from specifications, drawings, or equality must be noted by the Contractor when submitting alternate products or materials for approval. The Engineer shall be the sole judge of the equality and suitability of any products, materials, or components proposed by the Contractor as alternates to specified items. The Contractor shall bear all costs and make all secondary changes required to incorporate an approved substitute or alternate into the work. No offers for substitution will be acknowledged from suppliers, distributors, manufacturers, or subcontractors.

5.14 AVAILABILITY AND USE OF UTILITY SERVICES

- A. Owner shall make all reasonable utilities available to Contractor from existing outlets and supplies, as specified in the Contract Documents. Unless otherwise provided in the Contract Documents, the utility service consumed shall be charged to or paid for by Contractor at prevailing rates charged to Owner or, where the utility is produced by Owner, at reasonable rates determined by Owner. Contractor will carefully conserve any utilities furnished.
- B. Contractor shall, at its expense and in a skillful manner satisfactory to Owner, install and maintain all necessary temporary connections and distribution lines, together with appropriate protective devices, and all meters required to measure the amount of each utility used for the purpose of determining charges. Prior to the date of Final Acceptance, Contractor shall remove all temporary connections, distribution lines, meters, and associated equipment and materials.

5.15 TESTS AND INSPECTION

- A. Contractor shall maintain an adequate testing and inspection program and perform such tests and inspections as are necessary or required to ensure that the Work conforms to the requirements of the Contract Documents. Contractor shall be responsible for inspection and quality surveillance of all its Work and all Work performed by any Subcontractor. Unless otherwise provided, Contractor shall make arrangements for such tests, inspections, and approvals with an independent testing laboratory or entity acceptable to Owner, or with the appropriate public authority, and shall bear all related costs of tests, inspections, and approvals. Contractor shall give Owner timely notice of when and where tests and

GENERAL CONDITIONS FOR CONSTRUCTION AT WASHINGTON STATE PARKS

inspections are to be made. Contractor shall maintain complete inspection records and make them available to Owner.

- B. Owner may, at any reasonable time, conduct such inspections and tests as it deems necessary to ensure that the Work is in accordance with the Contract Documents. Owner shall promptly notify Contractor if an inspection or test reveals that the Work is not in accordance with the Contract Documents. Unless the subject items are expressly accepted by Owner, such Owner inspection and tests are for the sole benefit of Owner and do not:
 - 1. Constitute or imply acceptance;
 - 2. Relieve Contractor of responsibility for providing adequate quality control measures;
 - 3. Relieve Contractor of responsibility for risk of loss or damage to the Work, materials, or equipment;
 - 4. Relieve Contractor of its responsibility to comply with the requirements of the Contract Documents; or
 - 5. Impair Owner's right to reject defective or nonconforming items, or to avail itself of any other remedy to which it may be entitled.
- C. Neither observations by an inspector retained by Owner, the presence or absence of such inspector on the site, nor inspections, tests, or approvals by others, shall relieve Contractor from any requirement of the Contract Documents, nor is any such inspector authorized to change any term or condition of the Contract Documents.
- D. Contractor shall promptly furnish, without additional charge, all facilities, labor, material and equipment reasonably needed for performing such safe and convenient inspections and tests as may be required by Owner. Owner may charge Contractor any additional cost of inspection or testing when Work is not ready at the time specified by Contractor for inspection or testing, or when prior rejection makes re-inspection or retest necessary. Owner shall perform its inspections and tests in a manner that will cause no undue delay in the Work.
- E. The Owner shall have the right to appoint an Inspector who will have the authority to reject materials or workmanship which does not fulfill the requirements of these specifications. In case of dispute, the Contractor may appeal to the Engineer whose decision shall be final. The acceptance of any material by the Inspector shall not hinder its subsequent rejection if found defective. Rejected materials and workmanship shall be replaced promptly or be made good by the Contractor without additional cost to the Owner.
- F. Contractor shall deliver one (1) key for each type of lock installed on the project to the Engineer to enable the Engineer to enter all facilities under construction for the purpose of inspection. This includes temporary as well as State Parks' key-coded locks. All keys for key-coded locks shall be delivered to the Engineer as they are made available to the Contractor. These coded keys shall then be signed out to the Contractor on an accountable basis for security purposes.

5.16 CORRECTION OF NONCONFORMING WORK

- A. If a portion of the Work is covered contrary to the requirements in the Contract Documents, it must, if required in writing by Owner, be uncovered for Owner's observation and be replaced at the Contractor's expense and without change in the Contract Time.
- B. If, at any time prior to Final Completion, Owner desires to examine the Work, or any portion of it, which has been covered, Owner may request to see such Work and it shall be uncovered by Contractor. If such Work is in accordance with the Contract Documents, the Contractor shall be entitled to an adjustment in the Contract Sum for the costs of uncovering and replacement, and, if completion of the Work is thereby delayed, an adjustment in the Contract Time, provided it makes a request therefore as provided in part 7. If such Work is not in accordance with the Contract Documents, the Contractor shall pay the costs of examination and reconstruction.
- C. Contractor shall promptly correct Work found by Owner not to conform to the requirements of the Contract Documents, whether observed before or after Substantial Completion and whether or not fabricated, installed, or completed. Contractor shall bear all costs of correcting such nonconforming Work, including additional testing and inspections.

GENERAL CONDITIONS FOR CONSTRUCTION AT WASHINGTON STATE PARKS

- D. If, within one year after the date of Substantial Completion of the Work or designated portion thereof, or within one year after the date for commencement of any system warranties established under section 6.08, or within the terms of any applicable special warranty required by the Contract Documents, any of the Work is found to be not in accordance with the requirements of the Contract Documents, Contractor shall correct it promptly after receipt of written notice from Owner to do so. Owner shall give such notice promptly after discovery of the condition. This period of one year shall be extended, with respect to portions of Work first performed after Substantial Completion, by the period of time between Substantial Completion and the actual performance of the Work. Contractor's duty to correct with respect to Work repaired or replaced shall run for one year from the date of repair or replacement. Obligations under this paragraph shall survive Final Acceptance.
- E. Contractor shall remove from the Project site portions of the Work which are not in accordance with the requirements of the Contract Documents and are neither corrected by Contractor nor accepted by Owner.
- F. If Contractor fails to correct nonconforming Work within a reasonable time after written notice to do so, Owner may replace, correct, or remove the nonconforming Work and charge the cost thereof to the Contractor.
- G. Contractor shall bear the cost of correcting destroyed or damaged Work, whether completed or partially completed, caused by Contractor's correction or removal of Work which is not in accordance with the requirements of the Contract Documents.
- H. Nothing contained in this section shall be construed to establish a period of limitation with respect to other obligations which Contractor might have according to the Contract Documents. Establishment of the time period of one (1) year as described in paragraph 5.16D relates only to the specific obligation of Contractor to correct the Work, and has no relationship to the time within which the Contractor's obligation to comply with the Contract Documents may be sought to be enforced, including the time within which such proceedings may be commenced.
- I. If Owner prefers to accept Work which is not in accordance with the requirements of the Contract Documents, Owner may do so instead of requiring its removal and correction, in which case the Contract Sum may be reduced as appropriate and equitable.

5.17 CLEAN UP

Contractor shall at all times keep the Project site, including hauling routes, infrastructures, utilities, and storage areas, free from accumulations of waste materials. Before completing the Work, Contractor shall remove from the premises its rubbish, tools, scaffolding, equipment, and materials. Upon completing the Work, Contractor shall leave the Project site in a clean, neat, and orderly condition satisfactory to Owner. If Contractor fails to clean up as provided herein, and after reasonable notice from Owner, Owner may do so and the cost thereof shall be charged to Contractor.

5.18 ACCESS TO WORK

Contractor shall provide Owner and A/E access to the Work in progress wherever located.

5.19 OTHER CONTRACTS

Owner may undertake or award other contracts for additional work at or near the Project site. Contractor shall reasonably cooperate with the other contractors and with Owner's employees and shall carefully adapt scheduling and perform the Work in accordance with these Contract Documents to reasonably accommodate the other work.

5.20 SUBCONTRACTORS AND SUPPLIERS

- A. The Contractor shall include the language of this paragraph in each of its first tier subcontracts, and shall require each of its subcontractors to include the same language of this section in each of their subcontracts, adjusting only as necessary the terms used for the contracting parties. Upon request of the Owner, the Contractor shall promptly provide documentation to the Owner demonstrating that the subcontractor meets the subcontractor responsibility criteria below. The requirements of this paragraph apply to all subcontractors regardless of tier. At the time of subcontract execution, the Contractor shall verify that each of its first tier subcontractors meets the following bidder responsibility criteria:

GENERAL CONDITIONS FOR CONSTRUCTION AT WASHINGTON STATE PARKS

1. Have a current certificate of registration as a contractor in compliance with chapter 18.27 RCW, which must have been in effect at the time of subcontract bid submittal;
 2. Have a current Washington Unified Business Identifier (UBI) number;
 3. If applicable, have:
 - a. Industrial Insurance (workers' compensation) coverage for the subcontractor's employees working in Washington, as required in Title 51 RCW;
 - b. A Washington Employment Security Department number, as required in Title 50 RCW;
 - c. A Washington Department of Revenue state excise tax registration number, as required in Title 82 RCW;
 - d. An electrical contractor license, if required by Chapter 19.28 RCW;
 - e. An elevator contractor license, if required by Chapter 70.87 RCW.
 4. Not be disqualified from bidding on any public works contract under RCW 39.06.010 or 39.12.065 (3).
 5. On a project subject to the apprenticeship utilization requirements in RCW 39.04.320, not have been found out of compliance by the Washington state apprenticeship and training council for working apprentices out of ratio, without appropriate supervision, or outside their approved work processes as outlined in their standards of apprenticeship under chapter 49.04 RCW for the one-year period immediately preceding the date of the Owner's first advertisement of the project.
- B. Prior to submitting the first Application for Payment, Contractor shall furnish in writing to Owner, on Owner provided form(s), the names, addresses, telephone numbers, and Tax Identification Numbers (TIN) of all subcontractors, as well as suppliers providing materials in excess of \$2,500.00 which Contractor believes to be MBE or WBE owned businesses, or have identified themselves to the Contractor as MBE or WBE, or are Washington State OMWBE certified. The Contractor shall indicate the anticipated dollar value of each MWBE subcontract. Contractor shall utilize subcontractors and suppliers, which are experienced and qualified, and meet the requirements of the Contract Documents, if any. Contractor shall not utilize any subcontractor or supplier to whom the Owner has a reasonable objection, and shall obtain Owner's written consent before making any substitutions or additions. The Owner may direct the Contractor, at no additional cost to the Owner, to remove and substitute any subcontractor(s) found to be out of compliance with the "Off-Site Prefabricated Non-Standard Project Specific Items" reporting requirements more than one time as determined by the Department of Labor and Industries and as defined in EHB 2805 that amends RCW 39.04.
- C. All Subcontracts must be in writing. By appropriate written agreement, Contractor shall require each Subcontractor, so far as applicable to the Work to be performed by the Subcontractor, to be bound to Contractor by terms of the Contract Documents, and to assume toward Contractor all the obligations and responsibilities which Contractor assumes toward Owner in accordance with the Contract Documents. Each Subcontract shall preserve and protect the rights of Owner in accordance with the Contract Documents with respect to the Work to be performed by the Subcontractor so that subcontracting thereof will not prejudice such rights. Where appropriate, Contractor shall require each Subcontractor to enter into similar agreements with Sub-subcontractors. However, nothing in this paragraph shall be construed to alter the contractual relations between Contractor and its Subcontractors with respect to insurance or bonds.
- D. Contractor shall schedule, supervise, and coordinate the operations of all Subcontractors. No Subcontracting of any of the Work shall relieve Contractor from its responsibility for the performance of the Work in accordance with the Contract Documents or any other obligations of the Contract Documents.
- E. Each subcontract agreement for a portion of the Work is hereby assigned by Contractor to Owner provided that:
1. The assignment is effective only after termination by Owner for cause pursuant to section 9.01 and only for those Subcontracts which Owner accepts by notifying the Subcontractor in writing; and
 2. After the assignment is effective, Owner will assume all future duties and obligations toward the Subcontractor which Contractor assumed in the Subcontract.
 3. The assignment is subject to the prior rights of the surety, if any, obligated under any bond provided in accordance with the Contract Documents.

GENERAL CONDITIONS FOR CONSTRUCTION AT WASHINGTON STATE PARKS

5.21 WARRANTY OF CONSTRUCTION

- A. In addition to any special warranties provided elsewhere in the Contract Documents, Contractor warrants that all Work conforms to the requirements of the Contract Documents and is free of any defect in equipment, material, or design furnished, or workmanship performed, by Contractor.
- B. With respect to all warranties, express or implied, for Work performed or materials furnished according to the Contract Documents, Contractor shall:
 - 1. Obtain all warranties that would be given in normal commercial practice;
 - 2. Require all warranties to be executed, in writing, for the benefit of Owner;
 - 3. Enforce all warranties for the benefit of Owner, if directed by Owner; and
 - 4. Be responsible to enforce any subcontractor's, manufacturer's, or supplier's warranty should they extend beyond the period specified in the Contract Documents.
- C. The obligations under this section shall survive Final Acceptance.

5.22 INDEMNIFICATION

- A. Contractor shall defend, indemnify, and hold Owner and A/E harmless from and against all claims, demands, losses, damages, or costs, including but not limited to damages arising out of bodily injury or death to persons and damage to property, caused by or resulting from:
 - 1. The sole negligence of Contractor or any of its Subcontractors;
 - 2. The concurrent negligence of Contractor, or any Subcontractor, but only to the extent of the negligence of Contractor or such Subcontractor; and
 - 3. The use of any design, process, or equipment which constitutes an infringement of any United States patent presently issued, or violates any other proprietary interest, including copyright, trademark, and trade secret.
- B. In any action against Owner and any other entity indemnified in accordance with this section, by any employee of Contractor, its Subcontractors, Sub-subcontractors, agents, or anyone directly or indirectly employed by any of them, the indemnification obligation of this section shall not be limited by a limit on the amount or type of damages, compensation, or benefits payable by or for Contractor or any Subcontractor under RCW Title 51, the Industrial Insurance Act, or any other employee benefit acts. In addition, Contractor waives immunity as to Owner and A/E only, in accordance with RCW Title 51.

PART 6 - PAYMENTS AND COMPLETION

6.01 CONTRACT SUM

Owner shall pay Contractor the Contract Sum for performance of the Work, in accordance with the Contract Documents. The Contract Sum shall include all taxes imposed by law and properly chargeable to the Project, including sales tax.

6.02 SCHEDULE OF VALUES

Before submitting its first Application for Payment, Contractor shall submit to Owner for approval a breakdown allocating the total Contract Sum to each principle category of work, in such detail as requested by Owner ("Schedule of Values"). The approved Schedule of Values shall include appropriate amounts for demobilization, record drawings, O&M manuals, and any other requirements for Project closeout, and shall be used by Owner as the basis for progress payments. Payment for Work shall be made only for and in accordance with those items included in the Schedule of Values.

6.03 APPLICATION FOR PAYMENT

GENERAL CONDITIONS FOR CONSTRUCTION AT WASHINGTON STATE PARKS

- A. At monthly intervals, unless determined otherwise by Owner, Contractor shall submit to Owner an itemized Application for Payment for Work completed in accordance with the Contract Documents and the approved Schedule of Values. Each application shall be supported by such substantiating data as Owner may require.
- B. By submitting an Application for Payment, Contractor is certifying that all Subcontractors have been paid, less earned retainage in accordance with RCW 60.28.010, as their interests appeared in the last preceding certificate of payment. By submitting an Application for Payment, Contractor is recertifying that the representations set forth in section 1.03 are true and correct, to the best of Contractor's knowledge, as of the date of the Application for Payment.
- C. At the time it submits an Application for Payment, Contractor shall analyze and reconcile, to the satisfaction of Owner, the actual progress of the Work with the Progress Schedule.
- D. If authorized by Owner, the Application for Payment may include request for payment for material delivered to the Project site and suitably stored, or for completed preparatory work. Payment may similarly be requested for material stored off the Project site, provided Contractor complies with or furnishes satisfactory evidence of the following:
 - 1. The material will be placed in a warehouse that is structurally sound, dry, lighted, and suitable for the materials to be stored;
 - 2. The warehouse is located within a 10-mile radius of the Project. Other locations may be utilized, if approved in writing, by Owner;
 - 3. Only materials for the Project are stored within the warehouse (or a secure portion of a warehouse set aside for the Project);
 - 4. Contractor furnishes Owner a certificate of insurance extending Contractor's insurance coverage for damage, fire, and theft to cover the full value of all materials stored, or in transit;
 - 5. The warehouse (or secure portion thereof) is continuously under lock and key, and only Contractor's authorized personnel shall have access;
 - 6. Owner shall at all times have the right of access in company of Contractor;
 - 7. Contractor and its surety assume total responsibility for the stored materials; and
 - 8. Contractor furnishes to Owner certified lists of materials stored, bills of lading, invoices, and other information as may be required, and shall also furnish notice to Owner when materials are moved from storage to the Project site.

6.04 PROGRESS PAYMENTS

- A. Owner shall make progress payments, in such amounts as Owner determines are properly due, within 30 days after receipt of a properly executed Application for Payment. Owner shall notify Contractor in accordance with RCW 39.76 if the Application for Payment does not comply with the requirements of the Contract Documents.
- B. Owner shall retain 5% (five percent) of the amount of each progress payment until forty-five (45) days after Final Acceptance and receipt of all documents required by law or the Contract Documents, including, at Owner's request, consent of surety to release of the retainage. In accordance with RCW 60.28, Contractor may request that monies reserved be retained in a fund by Owner, deposited by Owner in a bank or savings and loan, or placed in escrow with a bank or trust company to be converted into bonds and securities to be held in escrow with interest to be paid to Contractor. Owner may permit Contractor to provide an appropriate bond in lieu of the retained funds.
- C. Title to all Work and materials covered by a progress payment shall pass to Owner at the time of such payment free and clear of all liens, claims, security interests, and encumbrances. Passage of title shall not, however, relieve Contractor from any of its duties and responsibilities for the Work or materials, or waive any rights of Owner to insist on full compliance by Contractor with the Contract Documents.

GENERAL CONDITIONS FOR CONSTRUCTION AT WASHINGTON STATE PARKS

- D. Payments due and unpaid in accordance with the Contract Documents shall bear interest as specified in RCW 39.76.

6.05 PAYMENTS WITHHELD

- A. Owner may withhold or, on account of subsequently discovered evidence, nullify the whole or part of any payment to such extent as may be necessary to protect Owner from loss or damage for reasons including but not limited to:
1. Work not in accordance with the Contract Documents;
 2. Reasonable evidence that the Work required by the Contract Documents cannot be completed for the unpaid balance of the Contract Sum;
 3. Work by Owner to correct defective Work or complete the Work in accordance with section 5.17;
 4. Failure to perform in accordance with the Contract Documents; or
 5. Cost or liability that may occur to Owner as the result of Contractor's fault or negligent acts or omissions.
- B. In any case where part or all of a payment is going to be withheld for unsatisfactory performance, Owner shall notify Contractor in accordance with RCW 39.76.

6.06 RETAINAGE AND BOND CLAIM RIGHTS

- A. Prior to release of the contract retainage, an "Affidavit of Wages Paid", approved by the Washington State Department of Labor and Industries, must be on file in the Owner's office. Contracts over \$20,000, including tax, necessitate a clearance from the Washington State Department of Revenue and the Washington State Department of Employment Security. The Owner shall initiate action for the releases from the Departments of Revenue and Employment Security.
- B. RCW chapters 39.08 and 60.28, concerning the rights and responsibilities of Contractor and Owner with regard to the performance and payment bonds and retainage, are made a part of the Contract Documents by reference as though fully set forth herein.
- C. In accordance with RCW 60.28, the lien period for filing liens against the contract retainage shall be forty-five (45) days. Persons performing labor or furnishing supplies toward the completion of the contract who intend to file a lien against the contract retainage must do so within forty-five (45) days from the date of Final Acceptance of the contract by the Owner and in the manner as described in RCW 39.08.030.

6.07 SUBSTANTIAL COMPLETION

Substantial Completion is the stage in the progress of the Work (or portion thereof designated and approved by Owner) when the construction is sufficiently complete, in accordance with the Contract Documents, so Owner can fully occupy the Work (or the designated portion thereof) for the use for which it is intended. All Work other than incidental corrective or punch list work shall be completed. Substantial Completion shall not have been achieved if all systems and parts are not functional, if utilities are not connected and operating normally, if all required occupancy permits have not been issued, or if the Work is not accessible by normal vehicular and pedestrian traffic routes. The date Substantial Completion is achieved shall be established in writing by Owner. Contractor may request an early date of Substantial Completion which must be approved by Change Order. Owner's occupancy of the Work or designated portion thereof does not necessarily indicate that Substantial Completion has been achieved.

6.08 PRIOR OCCUPANCY

- A. Owner may, upon written notice thereof to Contractor, take possession of or use any completed or partially completed portion of the Work ("Prior Occupancy") at any time prior to Substantial Completion. Unless otherwise agreed in writing, Prior Occupancy shall not: be deemed an acceptance of any portion of the Work; accelerate the time for any payment to Contractor; prejudice any rights of Owner provided by any insurance, bond, guaranty, or the Contract Documents; relieve Contractor of the risk of loss or any of the

GENERAL CONDITIONS FOR CONSTRUCTION AT WASHINGTON STATE PARKS

obligations established by the Contract Documents; establish a date for termination or partial termination of the assessment of liquidated damages; or constitute a waiver of claims.

- B. Notwithstanding anything in the preceding paragraph, Owner shall be responsible for loss of or damage to the Work resulting from Prior Occupancy. Contractor's one (1) year duty to repair and any system warranties shall begin on building systems activated and used by Owner as agreed in writing by Owner and Contractor.

6.09 FINAL COMPLETION, ACCEPTANCE, AND PAYMENT

- A. Final Completion shall be achieved when the Work is fully and finally complete in accordance with the Contract Documents. The date Final Completion is achieved shall be established by Owner in writing.
- B. Final Acceptance is the formal action of Owner acknowledging Final Completion. Prior to Final Acceptance, Contractor shall, in addition to all other requirements in the Contract Documents, submit to Owner a written notice of any outstanding disputes or claims between Contractor and any of its Subcontractors, including the amounts and other details thereof. Neither Final Acceptance, nor final payment, shall release Contractor or its sureties from any obligations of these Contract Documents or the Public Works Bond, or constitute a waiver of any claims by Owner arising from Contractor's failure to perform the Work in accordance with the Contract Documents.
- C. Acceptance of final payment by Contractor, or any Subcontractor, shall constitute a waiver and release to Owner of all claims by Contractor, or any such Subcontractor, for an increase in the Contract Sum or the Contract Time, and for every act or omission of Owner relating to or arising out of the Work, except for those Claims made in accordance with the procedures, including the time limits, set forth in part 8.

PART 7 - CHANGES

7.01 CHANGES IN THE WORK

- A. Owner may, at any time and without notice to Contractor's surety, order additions, deletions, revisions, or other changes in the Work. These changes in the Work shall be incorporated into the Contract Documents through the execution of Change Orders. If any change in the Work ordered by Owner causes an increase or decrease in the Contract Sum or the Contract Time, an equitable adjustment shall be made as provided in section 7.02 or 7.03, respectively, and such adjustment(s) shall be incorporated into a Change Order.
- B. If Owner desires to order a change in the Work, it may request a written Change Order Proposal (COP) from Contractor. Contractor shall submit a Change Order Proposal within 14 (fourteen) days of the request from Owner, or within such other period as mutually agreed. Contractor's Change Order Proposal shall be full compensation for implementing the proposed change in the Work, including any adjustment in the Contract Sum or Contract Time, and including compensation for all delays in connection with such change in the Work and for any expense or inconvenience, disruption of schedule, or loss of efficiency or productivity occasioned by the change in the Work.
- C. Upon receipt of the Change Order proposal, or a request for equitable adjustment in the Contract Sum or Contract Time, or both, as provided in sections 7.02 and 7.03, Owner may accept or reject the proposal, request further documentation, or negotiate acceptable terms with Contractor. Pending agreement on the terms of the Change Order, Owner may direct Contractor to proceed immediately with the Change Order Work. Contractor shall not proceed with any change in the Work until it has obtained Owner's approval. All Work done pursuant to any Owner-directed change in the Work shall be executed in accordance with the Contract Documents.
- D. If Owner and Contractor reach agreement on the terms of any change in the Work, including any adjustment in the Contract Sum or Contract Time, such agreement shall be incorporated in a Change Order. The Change Order shall constitute full payment and final settlement of all claims for time and for direct, indirect, and consequential costs, including costs of delays, inconvenience, disruption of schedule, or loss of efficiency or productivity, related to any Work either covered or affected by the Change Order, or related to the events giving rise to the request for equitable adjustment.

GENERAL CONDITIONS FOR CONSTRUCTION AT WASHINGTON STATE PARKS

- E. If Owner and Contractor are unable to reach agreement on the terms of any change in the Work, including any adjustment in the Contract Sum or Contract Time, Contractor may at any time in writing, request a final offer from Owner. Owner shall provide Contractor with its written response within 30 (thirty) days of Contractor's request. Owner may also provide Contractor with a final offer at any time. If Contractor rejects Owner's final offer, or the parties are otherwise unable to reach agreement, Contractor's only remedy shall be to file a Claim as provided in part 8.
- F. Field Authorization
1. The Field Authorization (FA) is executed as a directive to proceed with work when the processing time for an approved change order would impact the project.
 2. A scope of work must be defined, a maximum not to exceed cost agreed upon, and any estimated modification to the contract completion time determined. The method of final cost verification must be noted and supporting cost data must be submitted in accordance with the requirements of Part 7 of the General Conditions. Upon satisfactory submittal and approval of supporting cost data, the completed FA will be processed into a change order. No payment will be made to the Contractor for FA work until that FA is converted to a Change Order.

7.02 CHANGES IN THE CONTRACT SUM

A. General Application

1. The Contract Sum shall only be changed by a Change Order. Contractor shall include any request for a change in the Contract Sum in its Change Order Proposal.
2. If the cost of Contractor's performance is changed due to the fault or negligence of Owner, or anyone for whose acts Owner is responsible, Contractor shall be entitled to make a request for an equitable adjustment in the Contract Sum in accordance with the following procedure. No change in the Contract Sum shall be allowed to the extent: Contractor's changed cost of performance is due to the fault or negligence of Contractor, or anyone for whose acts Contractor is responsible; the change is concurrently caused by Contractor and Owner; or the change is caused by an act of Force Majeure as defined in Section 3.05.
 - a. A request for an equitable adjustment in the Contract Sum shall be based on written notice delivered to Owner within 7 (seven) days of the occurrence of the event giving rise to the request. For purposes of this part, "occurrence" means when Contractor knew, or in its diligent prosecution of the Work should have known, of the event giving rise to the request. If Contractor believes it is entitled to an adjustment in the Contract Sum, Contractor shall immediately notify Owner and begin to keep and maintain complete, accurate, and specific daily records. Contractor shall give Owner access to any such records and, if requested shall promptly furnish copies of such records to Owner.
 - b. Contractor shall not be entitled to any adjustment in the Contract Sum for any occurrence of events or costs that occurred more than 7 (seven) days before Contractor's written notice to Owner. The written notice shall set forth, at a minimum, a description of: the event giving rise to the request for an equitable adjustment in the Contract Sum; the nature of the impacts to Contractor and its Subcontractors of any tier, if any; and to the extent possible the amount of the adjustment in Contract Sum requested. Failure to properly give such written notice shall, to the extent Owner's interests are prejudiced, constitute a waiver of Contractor's right to an equitable adjustment.
 - c. Within 30 (thirty) days of the occurrence of the event giving rise to the request, unless Owner agrees in writing to allow an additional period of time to ascertain more accurate data, Contractor shall supplement the written notice provided in accordance with subparagraph a. above with additional supporting data. Such additional data shall include, at a minimum: the amount of compensation requested, itemized in accordance with the procedure set forth herein; specific facts, circumstances, and analysis that confirms not only that Contractor suffered the damages claimed, but that the damages claimed were actually a result of the act, event, or condition complained of and that the Contract Documents provide entitlement to an equitable adjustment to Contractor for such act, event, or condition; and documentation sufficiently detailed to permit an informed analysis

GENERAL CONDITIONS FOR CONSTRUCTION AT WASHINGTON STATE PARKS

of the request by Owner. When the request for compensation relates to a delay, or other change in Contract Time, Contractor shall demonstrate the impact on the critical path, in accordance with section 7.03C. Failure to provide such additional information and documentation within the time allowed or within the format required shall, to the extent Owner's interests are-prejudiced, constitute a waiver of Contractor's right to an equitable adjustment.

- d. Pending final resolution of any request made in accordance with this paragraph, unless otherwise agreed in writing, Contractor shall proceed diligently with performance of the Work.
 - e. Any requests by Contractor for an equitable adjustment in the Contract Sum and in the Contract Time that arise out of the same event(s) shall be submitted together.
3. The value of any Work covered by a Change Order, or of any request for an equitable adjustment in the Contract Sum, shall be determined by one of the following methods:
 - a. On the basis of a fixed price as determined in paragraph 7.02B.
 - b. By application of unit prices to the quantities of the items involved as determined in paragraph 7.02C.
 - c. On the basis of time and material as determined in paragraph 7.02D.
 4. When Owner has requested Contractor to submit a Change Order proposal, Owner may direct Contractor as to which method in subparagraph 3 above to use when submitting its proposal. Otherwise, Contractor shall determine the value of the Work, or a request for an equitable adjustment, on the basis of the fixed price method.

B. Change Order Pricing -- Fixed Price

When the fixed price method is used to determine the value of any Work covered by a Change Order or a request for an equitable adjustment in the Contract Sum, the following procedures shall apply:

1. Contractor's Change Order Proposal, or request for adjustment in the Contract Sum, shall be accompanied by a complete itemization of the costs, including labor, material, subcontractor costs, and overhead and profit. The costs shall be itemized in the manner set forth below, and shall be submitted on breakdown sheets in a form approved by Owner.
2. All costs shall be calculated based upon appropriate industry standard methods of calculating labor, material quantities, and equipment costs.
3. If any of Contractor's pricing assumptions are contingent upon anticipated actions of Owner, Contractor shall clearly state them in the proposal or request for an equitable adjustment.
4. The cost of any additive or deductive changes in the Work shall be calculated as set forth below, except that overhead and profit shall not be included on deductive changes in the Work. Where a change in the Work involves additive and deductive work by the same Contractor or Subcontractor, small tools, overhead, profit, bond, and insurance markups will apply to the net difference.
5. If the total cost of the change in the Work or request for equitable adjustment does not exceed \$1,000, Contractor shall not be required to submit a breakdown if the description of the change in the Work or request for equitable adjustment is sufficiently definitive for Owner to determine fair value.
6. If the total cost of the change in the Work or request for equitable adjustment is between \$1,000 and \$2,500, Contractor may submit a breakdown in the following level of detail if the description of the change in the Work or if the request for equitable adjustment is sufficiently definitive to permit the Owner to determine fair value:
 - a. lump sum labor;
 - b. lump sum material;
 - c. lump sum equipment usage;
 - d. overhead and profit as set forth below; and
 - e. insurance and bond costs as set forth below.

GENERAL CONDITIONS FOR CONSTRUCTION AT WASHINGTON STATE PARKS

7. Any request for adjustment of Contract Sum based upon the fixed price method shall include only the following items:
- a. Craft labor costs: These are the labor costs determined by multiplying the estimated or actual additional number of craft hours needed to perform the change in the Work by the hourly labor costs. Craft hours should cover direct labor, as well as indirect labor due to trade inefficiencies. The hourly costs shall be based on the following:
 - 1) Basic wages and benefits: Hourly rates and benefits as stated on the Department of Labor and Industries approved "statement of intent to pay prevailing wages." Direct supervision shall be a reasonable percentage not to exceed 15% (fifteen percent) of the cost of direct labor. No supervision markup shall be allowed for a working supervisor's hours.
 - 2) Worker's insurance: Direct contributions to the state of Washington for industrial insurance; medical aid; and supplemental pension, by the class and rates established by the Department of Labor and Industries.
 - 3) Federal insurance: Direct contributions required by the Federal Insurance Compensation Act; Federal Unemployment Tax Act; and the State Unemployment Compensation Act.
 - 4) Travel allowance: Travel allowance and/or subsistence, if applicable, not exceeding those allowances established by regional labor union agreements, which are itemized and identified separately.
 - 5) Safety: Cost incurred due to the Washington Industrial Safety and Health Act, which shall be a reasonable percentage not to exceed 2% (two percent) of the sum of the amounts calculated in (1), (2), and (3) above.
 - b. Material costs: This is an itemization of the quantity and cost of materials needed to perform the change in the Work. Material costs shall be developed first from actual known costs, second from supplier quotations or if these are not available, from standard industry pricing guides. Material costs shall consider all available discounts. Freight costs, express charges, or special delivery charges, shall be itemized.
 - c. Equipment costs: This is an itemization of the type of equipment and the estimated or actual length of time the construction equipment appropriate for the Work is or will be used on the change in the Work. Costs will be allowed for construction equipment only if used solely for the changed Work, or for additional rental costs actually incurred by the Contractor. Equipment charges shall be computed on the basis of actual invoice costs or if owned, from the current edition of one of the following sources:
 - 1) Associated General Contractors - Washington State Department of Transportation (AGC-WSDOT) Equipment Rental Agreement; current edition, on the Contract execution date.
 - 2) The state of Washington Utilities and Transportation Commission for trucks used on highways.
 - 3) The National Electrical Contractors Association for equipment used on electrical work.
 - 4) The Mechanical Contractors Association of America for equipment used on mechanical work.

The Data Quest Rental Rate (Blue Book) shall be used as a basis for establishing rental rates of equipment not listed in the above sources. The maximum rate for standby equipment shall not exceed that shown in the AGC WSDOT Equipment Rental Agreement, current edition, on the Contract execution date.
 - d. Allowance for small tools, expendables, and consumable supplies: Small tools consist of tools which cost \$250 or less and are normally furnished by the performing contractor. The maximum rate for small tools shall not exceed the following:

GENERAL CONDITIONS FOR CONSTRUCTION AT WASHINGTON STATE PARKS

- 1) For Contractor, 3% (three percent) of direct labor costs.
- 2) For Subcontractors, 5% (five percent) of direct labor costs.

Expendables and consumable supplies directly associated with the change in Work must be itemized.

- e. Subcontractor costs: This is defined as payments Contractor makes to Subcontractors for changed Work performed by Subcontractors of any tier. The Subcontractors' cost of Work shall be calculated and itemized in the same manner as prescribed herein for Contractor.
- f. Allowance for overhead: This is defined as costs of any kind attributable to direct and indirect delay, acceleration, or impact, added to the total cost to Owner of any change in the Contract Sum but not to the cost of any change in the Contract Time for which contractor has been compensated pursuant to the conditions set forth in Section 7.03. This allowance shall compensate Contractor for all non-craft labor, temporary construction facilities, field engineering, schedule updating, record drawings, home office cost, B&O taxes, office engineering, estimating costs, additional overhead because of extended time, and any other cost incidental to the change in the Work. It shall be strictly limited in all cases to a reasonable amount, mutually acceptable, or if none can be agreed upon to an amount not to exceed the rates below:

1) For projects where the Contract Award Amount is under \$3 million, the following shall apply:

- a) For Contractor, for any Work actually performed by Contractor's own forces, 16% (sixteen percent) of the first \$50,000 of the cost, and 4% (four percent) of the remaining cost, if any.
- b) For each Subcontractor (including lower tier subcontractors), for any Work actually performed by its own forces, 16% (sixteen percent) of the first \$50,000 of the cost, and 4% (four percent) of the remaining cost, if any.
- c) For Contractor, for any work performed by its Subcontractor(s), 6% (six percent) of the first \$50,000 of the amount due each Subcontractor, and 4% (four percent) of the remaining amount if any.
- d) For each Subcontractor, for any Work performed by its Subcontractor(s) of any lower tier, 4% (four percent) of the first \$50,000 of the amount due the sub-Subcontractor, and 2% (two percent) of the remaining amount if any.
- e) The cost to which overhead is to be applied shall be determined in accordance with subparagraphs a.-e. above.

2) For projects where the Contract Award Amount is equal to or exceeds \$3 million, the following shall apply:

- a) For Contractor, for any Work actually performed by Contractor's own forces, 12% (twelve percent) of the first \$50,000 of the cost, and 4% (four percent) of the remaining cost, if any.
- b) For each Subcontractor (including lower tier subcontractors), for any Work actually performed by its own forces, 12% (twelve percent) of the first \$50,000 of the cost, and 4% (four percent) of the remaining cost, if any.
- c) For Contractor, for any Work performed by its Subcontractor(s), 4% (four percent) of the first \$50,000 of the amount due each Subcontractor, and 2% (two percent) of the remaining amount if any.
- d) For each Subcontractor, for any Work performed by its Subcontractor(s) of any lower tier, 4% (four percent) of the first \$50,000 of the amount due the sub-Subcontractor, and 2% (two percent) of the remaining amount if any.

GENERAL CONDITIONS FOR CONSTRUCTION AT WASHINGTON STATE PARKS

- e) The cost to which overhead is to be applied shall be determined in accordance with subparagraphs a.- e. above.
- g. Allowance for profit: This is an amount to be added to the cost of any change in contract sum, but not to the cost of change in Contract Time for which contractor has been compensated pursuant to the conditions set forth in section 7.03. It shall be limited to a reasonable amount, mutually acceptable, or if none can be agreed upon, to an amount not to exceed the rates below:
 - 1) For Contractor or Subcontractor of any tier for work performed by their forces, 6% (six percent) of the cost developed in accordance with Section 7.02 b. 7a.- e.
 - 2) For Contractor or Subcontractor of any tier for work performed by a subcontractor of a lower tier, 4% (four percent) of the Subcontractor cost developed in accordance with Section 7.02 b. 7a. - h.
- h. Cost of change in insurance or bond premium: This is defined as:
 - 1) Contractor's liability insurance: The cost of any changes in Contractor's liability insurance arising directly from execution of the Change Order; and
 - 2) Public works bond: The cost of the additional premium for Contractor's bond arising directly from the changed Work.

The costs of any change in insurance or bond premium shall be added after overhead and allowance for profit are calculated in accordance with subparagraph f. and g. above.

C. Change Order Pricing -- Unit Prices

- 1. Whenever Owner authorizes Contractor to perform Work on a unit-price basis, Owner's authorization shall clearly state:
 - a. Scope of work to be performed;
 - b. Type of reimbursement including pre-agreed rates for material quantities; and
 - c. Cost limit of reimbursement.
- 2. Contractor shall:
 - a. Cooperate with Owner and assist in monitoring the Work being performed. As requested by Owner, Contractor shall identify workers assigned to the Change Order Work and areas in which they are working;
 - b. Leave access as appropriate for quantity measurement; and
 - c. Not exceed any cost limit(s) without Owner's prior written approval.
- 3. Contractor shall submit costs in accordance with paragraph 7.02B. and satisfy the following requirements:
 - a. Unit prices shall include reimbursement for all direct and indirect costs of the Work, including overhead and profit, and bond and insurance costs; and
 - b. Quantities must be supported by field measurement statements signed by Owner.

D. Change Order Pricing -- Time-and-Material Prices

- 1. Whenever Owner authorizes Contractor to perform Work on a time-and-material basis, Owner's authorization shall clearly state:
 - a. Scope of Work to be performed;
 - b. Type of reimbursement including pre-agreed rates, if any, for material quantities or labor; and
 - c. Cost limit of reimbursement.
- 2. Contractor shall:

GENERAL CONDITIONS FOR CONSTRUCTION AT WASHINGTON STATE PARKS

- a. Cooperate with Owner and assist in monitoring the Work being performed. As requested by Owner, identify workers assigned to the Change Order Work and areas in which they are working;
 - b. Identify on daily time sheets all labor performed in accordance with this authorization. Submit copies of daily time sheets within 2 working days for Owner's review;
 - c. Leave access as appropriate for quantity measurement;
 - d. Perform all Work in accordance with this section as efficiently as possible; and
 - e. Not exceed any cost limit(s) without Owner's prior written approval.
3. Contractor shall submit costs in accordance with paragraph 7.02B and additional verification supported by:
- a. Labor detailed on daily time sheets; and
 - b. Invoices for material.

7.03 CHANGES IN THE CONTRACT TIME

- A. The Contract Time shall only be changed by a Change Order. Contractor shall include any request for a change in the Contract Time in its Change Order Proposal.
- B. If the time of Contractor's performance is changed due to an act of Force Majeure, or due to the fault or negligence of Owner or anyone for whose acts Owner is responsible, Contractor shall be entitled to make a request for an equitable adjustment in the Contract Time in accordance with the following procedure. No adjustment in the Contract Time shall be allowed to the extent Contractor's changed time of performance is due to the fault or negligence of Contractor, or anyone for whose acts Contractor is responsible.
1. A request for an equitable adjustment in the Contract Time shall be based on written notice delivered within 7 (seven) days of the occurrence of the event giving rise to the request. If Contractor believes it is entitled to adjustment of Contract Time, Contractor shall immediately notify Owner and begin to keep and maintain complete, accurate, and specific daily records. Contractor shall give Owner access to any such record and if requested, shall promptly furnish copies of such record to Owner.
 2. Contractor shall not be entitled to an adjustment in the Contract Time for any events that occurred more than 7 (seven) days before Contractor's written notice to Owner. The written notice shall set forth, at a minimum, a description of: the event giving rise to the request for an equitable adjustment in the Contract Time; the nature of the impacts to Contractor and its Subcontractors of any tier, if any; and to the extent possible the amount of the adjustment in Contract Time requested. Failure to properly give such written notice shall, to the extent Owner's interests are prejudiced, constitute a waiver of Contractor's right to an equitable adjustment.
 3. Within 30 (thirty) days of the occurrence of the event giving rise to the request, unless Owner agrees in writing to allow an additional period of time to ascertain more accurate data, Contractor shall supplement the written notice provided in accordance with subparagraph 7.03B.2 with additional supporting data. Such additional data shall include, at a minimum: the amount of delay claimed, itemized in accordance with the procedure set forth herein; specific facts, circumstances, and analysis that confirms not only that Contractor suffered the delay claimed, but that the delay claimed was actually a result of the act, event, or condition complained of, and that the Contract Documents provide entitlement to an equitable adjustment in Contract Time for such act, event, or condition; and supporting documentation sufficiently detailed to permit an informed analysis of the request by Owner. Failure to provide such additional information and documentation within the time allowed or within the format required shall, to the extent Owner's interests are prejudiced, constitute a waiver of Contractor's right to an equitable adjustment.
 4. Pending final resolution of any request in accordance with this paragraph, unless otherwise agreed in writing, Contractor shall proceed diligently with performance of the Work.
- C. Any change in the Contract Time covered by a Change Order, or based on a request for an equitable adjustment in the Contract Time, shall be limited to the change in the critical path of Contractor's schedule attributable to the change of Work or event(s) giving rise to the request for equitable adjustment. Any Change Order proposal or request for an adjustment in the Contract Time shall demonstrate the impact on the critical path of the schedule. Contractor shall be responsible for showing clearly on the Progress

GENERAL CONDITIONS FOR CONSTRUCTION AT WASHINGTON STATE PARKS

Schedule that the change or event: had a specific impact on the critical path, and except in case of concurrent delay, was the sole cause of such impact; and could not have been avoided by resequencing of the Work or other reasonable alternatives.

- D. Contractor may request compensation for the cost of a change in Contract Time in accordance with this paragraph, 7.03D, subject to the following conditions:
1. The change in Contract Time shall solely be caused by the fault or negligence of Owner or A/E;
 2. Compensation under this paragraph is limited to changes in Contract Time for which Contractor is not entitled to be compensated under section 7.02;
 3. Contractor shall follow the procedure set forth in paragraph 7.03B;
 4. Contractor shall establish the extent of the change in Contract Time in accordance with paragraph 7.03C; and
 5. The daily cost of any change in Contract Time shall be limited to the items below, less funds that may have been paid pursuant to a change in the Contract Sum that contributed to this change in Contract Time:
 - a. cost of nonproductive field supervision or labor extended because of the delay;
 - b. cost of weekly meetings or similar indirect activities extended because of the delay;
 - c. cost of temporary facilities or equipment rental extended because of the delay;
 - d. cost of insurance extended because of the delay;
 - e. general and administrative overhead in an amount to be agreed upon, but not to exceed 3% (three percent) of Contract Sum divided by the Contract Time for each day of the delay.

PART 8 - CLAIMS AND DISPUTE RESOLUTION

8.01 CLAIMS PROCEDURE

- A. If the parties fail to reach agreement on the terms of any Change Order for Owner-directed Work as provided in section 7.01, or on the resolution of any request for an equitable adjustment in the Contract Sum as provided in section 7.02 or the Contract Time as provided in section 7.03, Contractor's only remedy shall be to file a Claim with Owner as provided in this section.
- B. Contractor shall file its Claim within the earlier of: 120 (one hundred twenty) days from Owner's final offer in accordance with either paragraph 7.01E or the date of Final Acceptance.
- C. The Claim shall be deemed to cover all changes in cost and time (including direct, indirect, impact, and consequential) to which Contractor may be entitled. It shall be fully substantiated and documented. At a minimum, the Claim shall contain the following information:
1. A detailed factual statement of the Claim for additional compensation and time, if any, providing all necessary dates, locations, and items of Work affected by the Claim;
 2. The date on which facts arose which gave rise to the Claim
 3. The name of each employee of Owner or A/E knowledgeable about the Claim;
 4. The specific provisions of the Contract Documents which support the Claim;
 5. The identification of any documents and the substance of any oral communications that support the Claim;
 6. Copies of any identified documents, other than the Contract Documents, that support the Claim;
 7. If an adjustment in the Contract Time is sought: the specific days and dates for which it is sought; the specific reasons Contractor believes an extension in the Contract Time should be granted; and

GENERAL CONDITIONS FOR CONSTRUCTION AT WASHINGTON STATE PARKS

Contractor's analysis of its Progress Schedule to demonstrate the reason for the extension in Contract Time;

8. If an adjustment in the Contract Sum is sought, the exact amount sought and a breakdown of that amount into the categories set forth in, and in the detail required by, section 7.02; and
 9. A statement certifying, under penalty of perjury, that the Claim is made in good faith, that the supporting cost and pricing data are true and accurate to the best of Contractor's knowledge and belief, that the Claim is fully supported by the accompanying data, and that the amount requested accurately reflects the adjustment in the Contract Sum or Contract Time for which Contractor believes Owner is liable.
- D. After Contractor has submitted a fully documented Claim that complies with all applicable provisions of parts 7 and 8, Owner shall respond, in writing, to Contractor as follows:
1. If the Claim amount is less than \$50,000, with a decision within 60 (sixty) days from the date the Claim is received; or
 2. If the Claim amount is \$50,000 or more, with a decision within 60 (sixty) days from the date the Claim is received, or with notice to Contractor of the date by which it will render its decision. Owner will then respond with a written decision in such additional time.
- E. To assist in the review of Contractor's Claim, Owner may visit the Project site, or request additional information, in order to fully evaluate the issues raised by the Claim. Contractor shall proceed with performance of the Work pending final resolution of any Claim. Owner's written decision as set forth above shall be final and conclusive as to all matters set forth in the Claim, unless Contractor follows the procedure set forth in section 8.02.
- F. Any Claim of the Contractor against the Owner for damages, additional compensation, or additional time, shall be conclusively deemed to have been waived by the Contractor unless timely made in accordance with the requirements of this section.

8.02 ARBITRATION

- A. If Contractor disagrees with Owner's decision rendered in accordance with paragraph 8.01D, Contractor shall provide Owner with a written demand for arbitration. No demand for arbitration of any such Claim shall be made later than 30 (thirty) days after the date of Owner's decision on such Claim; failure to demand arbitration within said 30-day period shall result in Owner's decision being final and binding upon Contractor and its Subcontractors.
- B. Notice of the demand for arbitration shall be filed with the American Arbitration Association (AAA), with a copy provided to Owner. The parties shall negotiate or mediate under the Voluntary Construction Mediation Rules of the AAA, or mutually acceptable service, before seeking arbitration in accordance with the Construction Industry Arbitration Rules of AAA as follows:
1. Disputes involving \$30,000 or less shall be conducted in accordance with the Northwest Region Expedited Commercial Arbitration Rules; or
 2. Disputes over \$30,000 shall be conducted in accordance with the Construction Industry Arbitration Rules of the AAA, unless the parties agree to use the expedited rules.
- C. All Claims arising out of the Work shall be resolved by arbitration. The judgment upon the arbitration award may be entered, or review of the award may occur, in the superior court having jurisdiction thereof. No independent legal action relating to or arising from the Work shall be maintained.
- D. Claims between Owner and Contractor, Contractor and its Subcontractors, Contractor and A/E, and Owner and A/E shall, upon demand by Owner, be submitted in the same arbitration or mediation.
- E. If the parties resolve the Claim prior to arbitration judgment, the terms of the resolution shall be incorporated in a Change Order. The Change Order shall constitute full payment and final settlement of the Claim, including all claims for time and for direct, indirect, or consequential costs, including costs of delays, inconvenience, disruption of schedule, or loss of efficiency or productivity.

GENERAL CONDITIONS FOR CONSTRUCTION AT WASHINGTON STATE PARKS

8.03 CLAIMS AUDITS

- A. All Claims filed against Owner shall be subject to audit at any time following the filing of the Claim. Failure of Contractor, or Subcontractors of any tier, to maintain and retain sufficient records to allow Owner to verify all or a portion of the Claim or to permit Owner access to the books and records of Contractor, or Subcontractors of any tier, shall constitute a waiver of the Claim and shall bar any recovery.
- B. In support of Owner audit of any Claim, Contractor shall, upon request, promptly make available to Owner the following documents:
1. Daily time sheets and supervisor's daily reports;
 2. Collective bargaining agreements;
 3. Insurance, welfare, and benefits records;
 4. Payroll registers;
 5. Earnings records;
 6. Payroll tax forms;
 7. Material invoices, requisitions, and delivery confirmations;
 8. Material cost distribution worksheet;
 9. Equipment records (list of company equipment, rates, etc.);
 10. Vendors', rental agencies', Subcontractors', and agents' invoices;
 11. Contracts between Contractor and each of its Subcontractors, and all lower-tier Subcontractor contracts and supplier contracts;
 12. Subcontractors' and agents' payment certificates;
 13. Cancelled checks (payroll and vendors);
 14. Job cost report, including monthly totals;
 15. Job payroll ledger;
 16. Planned resource loading schedules and summaries;
 17. General ledger;
 18. Cash disbursements journal;
 19. Financial statements for all years reflecting the operations on the Work. In addition, the Owner may require, if it deems it appropriate, additional financial statements for 3 (three) years preceding execution of the Work;
 20. Depreciation records on all company equipment whether these records are maintained by the company involved, its accountant, or others;
 21. If a source other than depreciation records is used to develop costs for Contractor's internal purposes in establishing the actual cost of owning and operating equipment, all such other source documents;
 22. All non-privileged documents which relate to each and every Claim together with all documents which support the amount of any adjustment in Contract Sum or Contract Time sought by each Claim;
 23. Work sheets or software used to prepare the Claim establishing the cost components for items of the Claim including but not limited to labor, benefits and insurance, materials, equipment, Subcontractors,

GENERAL CONDITIONS FOR CONSTRUCTION AT WASHINGTON STATE PARKS

all documents which establish the time periods, individuals involved, the hours for the individuals, and the rates for the individuals; and

24. Work sheets, software, and all other documents used by Contractor to prepare its bid.

- C. The audit may be performed by employees of Owner or a representative of Owner. Contractor, and its Subcontractors, shall provide adequate facilities acceptable to Owner, for the audit during normal business hours. Contractor, and all Subcontractors, shall make a good faith effort to cooperate with Owner's auditors.

PART 9 - TERMINATION OF THE WORK

9.01 TERMINATION BY OWNER FOR CAUSE

- A. Owner may, upon 7 (seven) days written notice to Contractor and to its surety, terminate (without prejudice to any right or remedy of Owner) the Work, or any part of it, for cause upon the occurrence of any one or more of the following events:
1. Contractor fails to prosecute the Work or any portion thereof with sufficient diligence to ensure Substantial Completion of the Work within the Contract Time;
 2. Contractor is adjudged bankrupt, makes a general assignment for the benefit of its creditors or a receiver is appointed on account of its insolvency;
 3. Contractor fails in a material way to replace or correct Work not in conformance with the Contract Documents;
 4. Contractor repeatedly fails to supply skilled workers or proper materials or equipment;
 5. Contractor repeatedly fails to make prompt payment due to Subcontractors or for labor;
 6. Contractor materially disregards or fails to comply with laws, ordinances, rules, regulations, or orders of any public authority having jurisdiction; or
 7. Contractor is otherwise in material breach of any provision of the Contract Documents.
- B. Upon termination, Owner may at its option:
1. Take possession of the Project site and take possession of or use all materials, equipment, tools, and construction equipment and machinery thereon owned by Contractor to maintain the orderly progress of, and to finish, the Work;
 2. Accept assignment of subcontracts pursuant to section 5.20; and
 3. Finish the Work by whatever other reasonable method it deems expedient.
- C. Owner's rights and duties upon termination are subject to the prior rights and duties of the surety, if any, obligated under any bond provided in accordance with the Contract Documents.
- D. When Owner terminates the Work in accordance with this section, Contractor shall take the actions set forth in paragraph 9.02B, and shall not be entitled to receive further payment until the Work is accepted.
- E. If the unpaid balance of the Contract Sum exceeds the cost of finishing the Work, including compensation for A/E's services and expenses made necessary thereby and any other extra costs or damages incurred by Owner in completing the Work, or as a result of Contractor's actions, such excess shall be paid to Contractor. If such costs exceed the unpaid balance, Contractor shall pay the difference to Owner. These obligations for payment shall survive termination.
- F. Termination of the Work in accordance with this section shall not relieve Contractor or its surety of any responsibilities for Work performed.

GENERAL CONDITIONS FOR CONSTRUCTION AT WASHINGTON STATE PARKS

- G. If Owner terminates Contractor for cause, and it is later determined that none of the circumstances set forth in paragraph 9.01A exist, then such termination shall be deemed a termination for convenience pursuant to section 9.02.

9.02 TERMINATION BY OWNER FOR CONVENIENCE

- A. Owner may, upon written notice, terminate (without prejudice to any right or remedy of Owner) the Work, or any part of it, for the convenience of Owner.
- B. Unless Owner directs otherwise, after receipt of a written notice of termination for either cause or convenience, Contractor shall promptly:
1. Stop performing Work on the date and as specified in the notice of termination;
 2. Place no further orders or subcontracts for materials, equipment, services or facilities, except as may be necessary for completion of such portion of the Work as is not terminated;
 3. Cancel all orders and subcontracts, upon terms acceptable to Owner, to the extent that they relate to the performance of Work terminated;
 4. Assign to Owner all of the right, title, and interest of Contractor in all orders and subcontracts;
 5. Take such action as may be necessary or as directed by Owner to preserve and protect the Work, Project site, and any other property related to this Project in the possession of Contractor in which Owner has an interest; and
 6. Continue performance only to the extent not terminated.
- C. If Owner terminates the Work or any portion thereof for convenience, Contractor shall be entitled to make a request for an equitable adjustment for its reasonable direct costs incurred prior to the effective date of the termination, plus a reasonable allowance for overhead and profit on Work performed prior to termination, plus the reasonable administrative costs of the termination, but shall not be entitled to any other costs or damages, whatsoever, provided however, the total sum payable upon termination shall not exceed the Contract Sum reduced by prior payments. Contractor shall be required to make its request in accordance with the provisions of part 7.
- D. If Owner terminates the Work or any portion thereof for convenience, the Contract Time shall be adjusted as determined by Owner.

PART 10 - MISCELLANEOUS PROVISIONS

10.01 GOVERNING LAW

The Contract Documents and the rights of the parties herein shall be governed by the laws of the state of Washington. Venue shall be in the county in which Owner's principal place of business is located, unless otherwise specified.

10.02 SUCCESSORS AND ASSIGNS

Owner and Contractor respectively bind themselves, their partners, successors, assigns, and legal representatives to the other party hereto and to partners, successors, assigns, and legal representatives of such other party in respect to covenants, agreements, and obligations contained in the Contract Documents. Neither party shall assign the Work without written consent of the other, except that Contractor may assign the Work for security purposes, to a bank or lending institution authorized to do business in the state of Washington. If either party attempts to make such an assignment without such consent, that party shall nevertheless remain legally responsible for all obligations set forth in the Contract Documents.

10.03 MEANING OF WORDS

Unless otherwise stated in the Contract Documents, words which have well-known technical or construction industry meanings are used in the Contract Documents in accordance with such recognized meanings. Reference to standard specifications, manuals, or codes of any technical society, organization, or association, or

GENERAL CONDITIONS FOR CONSTRUCTION AT WASHINGTON STATE PARKS

to the code of any governmental authority, whether such reference be specific or by implication, shall be to the latest standard specification, manual, or code in effect on the date for submission of bids, except as may be otherwise specifically stated. Wherever in these Drawings and Specifications an article, device, or piece of equipment is referred to in the singular manner, such reference shall apply to as many such articles as are shown on the drawings, or required to complete the installation.

10.04 RIGHTS AND REMEDIES

No action or failure to act by Owner or A/E shall constitute a waiver of a right or duty afforded them under the Contract Documents, nor shall such action or failure to act constitute approval of an acquiescence in a breach therein, except as may be specifically agreed in writing.

10.05 CONTRACTOR REGISTRATION

Pursuant to RCW 39.06, Contractor shall be registered or licensed as required by the laws of the State of Washington, including but not limited to RCW 18.27.

10.06 TIME COMPUTATIONS

When computing any period of time, the day of the event from which the period of time begins shall not be counted. The last day is counted unless it falls on a weekend or legal holiday, in which event the period runs until the end of the next day that is not a weekend or holiday. When the period of time allowed is less than 7 (seven) days, intermediate Saturdays, Sundays, and legal holidays are excluded from the computation.

10.07 RECORDS RETENTION

The wage, payroll, and cost records of Contractor, and its Subcontractors, and all records subject to audit in accordance with section 8.03, shall be retained for a period of not less than 6 (six) years after the date of Final Acceptance.

10.08 THIRD-PARTY AGREEMENTS

The Contract Documents shall not be construed to create a contractual relationship of any kind between: A/E and Contractor; Owner and any Subcontractor; or any persons other than Owner and Contractor.

10.09 ANTITRUST ASSIGNMENT

Owner and Contractor recognize that in actual economic practice, overcharges resulting from antitrust violations are in fact usually borne by the purchaser. Therefore, Contractor hereby assigns to Owner any and all claims for such overcharges as to goods, materials, and equipment purchased in connection with the Work performed in accordance with the Contract Documents, except as to overcharges which result from antitrust violations commencing after the Contract Sum is established and which are not passed on to Owner under a Change Order. Contractor shall put a similar clause in its Subcontracts, and require a similar clause in its sub-Subcontracts, such that all claims for such overcharges on the Work are passed to Owner by Contractor.

10.10 MINORITY AND WOMEN'S BUSINESS ENTERPRISES (MWBE) PARTICIPATION

In Accordance with the legislative findings and policies set forth in Chapter 39.19 RCW the State of Washington encourages participation in all of its contracts by MWBE firms certified by the Office of Minority and Women's Business Enterprises (OMWBE). Participation may be either on a direct basis in response to this solicitation or as a subcontractor to a Bidder. Any affirmative action requirements set forth in federal regulations or statutes included or referenced in the contract documents will apply. Bidders may contact OMWBE to obtain information on certified firms for potential subcontractors/suppliers.

- A. When referred to in this Contract, the terms Minority Business Enterprise (MBE) and Women's Business Enterprise (WBE) will be as defined by OMWBE, WAC 326-02-030.

GENERAL CONDITIONS FOR CONSTRUCTION AT WASHINGTON STATE PARKS

- B. The OMWBE has compiled a directory of certified firms. Copies of this directory may be obtained through the OMWBE. For information regarding the certification process or the certification status of a particular firm, contact:
- OMWBE, 406 South Water Street, PO Box 41160, Olympia, WA 98504-1160, telephone (360) 753-9693.
- C. Eligible MWBEs or M/W firms
- MWBE firms utilized for this project for voluntary MWBE goals may be certified by Washington State OMWBE or self identified as minority or women owned (M/W firm).
- D. MWBE Voluntary Goals
- The Owner has established voluntary goals for MWBE participation for this project. The voluntary goals are set forth in the Advertisement for Bids.
- E. If any part of the contract, including the supply of materials and equipment, is anticipated to be subcontracted, then prior to receipt of the first payment, Contractor shall submit, pursuant to Section 5.20 A, a list of all subcontractors/suppliers it intends to use, designate whether any of the subcontractors/suppliers are MWBE firms, indicate the anticipated dollar value of each MWBE subcontract, and provide Tax Identification Number (TIN).
- F. If any part of the contract, including the supply of materials and equipment is actually subcontracted during completion of the work, then prior to final acceptance or completion of the contract or as otherwise indicated in the contract documents, the Contractor shall submit a statement of participation indicating what MWBEs were used and the dollar value of their subcontracts.
- G. The provisions of this section are not intended to replace or otherwise change the requirements of RCW 39.30.060. If said statute is applicable to this contract then the failure to comply with RCW 39.30.060 will still render a bid non-responsive.
- H. The Contractor shall maintain, for at least three years after completion of this contract, relevant records and information necessary to document the level of utilization of MWBEs and other businesses as subcontractors and suppliers in this contract, as well as any efforts the Contractor makes to increase the participation of MWBEs as listed in section I below. The Contractor shall also maintain, for at least three years after completion of this contract, a record of all quotes, bids, estimates, or proposals submitted to the Contractor by all businesses seeking to participate as subcontractors or suppliers in this contract. The state shall have the right to inspect and copy such records. If this contract involves federal funds, Contractor shall comply with all record keeping requirements set forth in any federal rules, regulations, or statutes included or referenced in the contract documents.
- I. Bidders should advertise opportunities for subcontractors or suppliers in a manner reasonably designed to provide MWBEs capable of performing the work with timely notice of such opportunities, and all advertisements shall include a provision encouraging participation by MWBE firms. Advertising may be done through general advertisements (e.g. newspapers, journals, etc.) or by soliciting bids directly from MWBEs. Bidders shall provide MWBEs that express interest with adequate and timely information about plans, specifications, and requirements of the contract.
- J. Contractors shall not create barriers to open and fair opportunities for all businesses including MWBEs to participate in all State contracts and to obtain or compete for contracts and subcontracts as sources of supplies, equipment, construction and services.
- K. Any violation of the mandatory requirements of this part of the contract shall be a material breach of contract for which the Contractor may be subject to a requirement of specific performance, or damages and sanctions provided by contract, by RCW 39.19.090, or by other applicable laws.

10.11 MINIMUM LEVELS OF APPRENTICESHIP PARTICIPATION

In accordance with Executive Order 00-01 the State of Washington may require apprenticeship participation for projects of a certain cost. The bid advertisement and Bid Proposal form shall establish the minimum percentage of apprentice labor hours as compared to the total labor hours.

GENERAL CONDITIONS FOR CONSTRUCTION AT WASHINGTON STATE PARKS

- A. Voluntary workforce diversity goals have been established for the apprentice hours. These goals are that one-fifth (1/5) of the apprentice hours be performed by minorities, and one-sixth (1/6) of the apprentice hours be performed by women.
- B. Apprentice participation, under this contract, may be counted towards the required percentage (%) only if the apprentices are from an apprenticeship program registered and approved by the Washington State Apprenticeship and Training Council (RCW 49.04 and WAC 296-04).
- C. Bidders may contact the Department of Labor and Industries, Specialty Compliance Services Division, Apprenticeship Section, P.O. Box 44530, Olympia, WA 98504-4530 by phone at (360) 902-5320, and e-mail at thum235@lni.wa.gov, to obtain information on available apprenticeship programs.
- D. For each project that has apprentice requirements, the contractor shall submit a "Statement of Apprentice/Journeyman Participation" on forms provided by the Department of General Administration, with every request for progress payment. The Contractor shall submit consolidated and cumulative data collected by the Contractor and collected from all subcontractors by the Contractor. The data to be collected and submitted includes the following:
1. Contractor name and address
 2. Contract number
 3. Project name
 4. Contract value
 5. Reporting period "Notice to Proceed" through "Invoicing Date"
 6. Craft/trade/occupation of all (contractor and subcontractor trades working on the project) apprentices and journeymen
 7. Total number of apprentices and total number of hours worked by apprentices, both categorized by gender and ethnicity
 8. Total number of journeymen and total number of hours worked by journeymen, both categorized by gender and ethnicity
 9. Cumulative combined total of apprentice and journeymen labor hours.
 10. Total percentage of apprentice hours worked
 11. No changes to the required percentage (%) of apprentice participation shall be allowed without written approval of the Owner. In any request for the change the Contractor shall clearly demonstrate a good faith effort to comply with the requirements for apprentice participation.
 12. Any substantive violation of the mandatory requirements of this part of the contract may be a material breach of the contract by the Contractor. The Owner may withhold payment pursuant to Part 6.05, stop the work for cause pursuant to Part 3.04, and terminate the contract for cause pursuant to Part 9.01.

10.12 HEADINGS AND CAPTIONS

Headings for convenience only: All headings and captions used in these General Conditions are only for convenience of reference, and shall not be used in any way in connection with the meaning, effect, interpretation, construction, or enforcement of the General Conditions, and do not define the limit or describe the scope or intent of any provision of these General Conditions.

END OF CONDITIONS

/ / / / /

Approved as to Form:
William Van Hook /s/
Asst. Attorney General
02/2007
08/2010 GA Updates – jrc
09/2010 to AAG Schwartz

**NISQUALLY STATE PARK
NEW FULL SERVICE PARK – PHASE 2**

The State of Washington prevailing wage rates are applicable for this public works project located in Pierce County. Bidders are responsible to verify and use the most recent prevailing wage rates. The “Effective Date” for this project is the Bid Proposal due date. The applicable prevailing wage rates may be found on the Department of Labor and Industries website located at:

<https://secure.lni.wa.gov/wagelookup/>

**Geotechnical Engineering Services Revised
Report**

Area 1
Proposed Maintenance Facility
Nisqually State Park
Pierce County, Washington

for
Robert W. Droll, Landscape Architects

December 22, 2020



Geotechnical Engineering Services Revised Report

Area 1
Proposed Maintenance Facility
Nisqually State Park
Pierce County, Washington

for
Robert W. Droll, Landscape Architects

December 22, 2020



1101 South Fawcett Avenue, Suite 200
Tacoma, Washington 98402
253.383.4940

Geotechnical Engineering Services Revised Report

Area 1 Proposed Maintenance Facility Nisqually State Park Pierce County, Washington

File No. 2935-067-00

December 22, 2020

Prepared for:

Robert W. Droll, Landscape Architects
4405 7th Avenue SE
Lacey, Washington 98503

Attention: Bob Droll

Prepared by:

GeoEngineers, Inc.
1101 South Fawcett Avenue, Suite 200
Tacoma, Washington 98402
253.383.4940

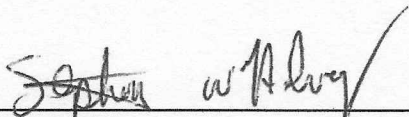

Stephen W. Helvey, LG, LEG, LHG
Senior Engineering Geologist

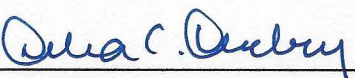

Debra C. Overbay, PE
Associate



SWH:DCO:tt

Disclaimer: Any electronic form, facsimile or hard copy of the original document (email, text, table, and/or figure), if provided, and any attachments are only a copy of the original document. The original document is stored by GeoEngineers, Inc. and will serve as the official document of record.

Table of Contents

1.0 INTRODUCTION AND PROJECT UNDERSTANDING.....	1
2.0 SCOPE OF SERVICES.....	1
3.0 SURFACE CONDITIONS.....	2
3.1. Geologic Conditions.....	2
4.0 FIELD EXPLORATION AND LABORATORY TESTING	3
4.1. Field Explorations.....	3
4.2. Laboratory Testing.....	3
4.3. Subsurface Conditions	3
4.3.1. Groundwater.....	3
4.4. Borrow Pit.....	3
5.0 CONCLUSIONS AND RECOMMENDATIONS.....	4
5.1. Summary of Geotechnical Considerations.....	4
5.2. Site Preparation and Earthwork.....	5
5.2.1. General.....	5
5.2.2. Stripping and Clearing.....	5
5.2.3. Subgrade Evaluation	5
5.2.4. Excavation.....	5
5.2.5. Excavation Support	6
5.2.6. Weather Considerations	6
5.2.7. Erosion and Sedimentation Control	6
5.3. Fill Materials.....	7
5.3.1. On-site Soils	7
5.3.2. Borrow Pit Soils.....	7
5.3.3. Select Granular Fill	8
5.3.4. Pipe Bedding.....	8
5.3.5. Crushed Rock	8
5.4. Fill Placement and Compaction	8
5.4.1. General.....	8
5.4.2. Area Fills and Bases.....	8
5.4.3. Trench Backfill	9
5.5. Temporary and Permanent Slopes	9
5.6. Foundation Support.....	9
5.6.1. Shallow Foundations.....	9
5.6.2. Bearing Capacity.....	9
5.6.3. Footing Subgrade Preparation.....	10
5.6.4. Foundation Settlement	10
5.6.5. Lateral Resistance.....	10
5.6.6. Building Pad and Floor Slabs.....	10
5.7. Parking and Driveway Recommendations.....	11
5.7.1. General.....	11
5.7.2. Asphaltic Pavement.....	11
5.8. Seismic Design Parameters	12

5.9. Liquefaction Potential..... 12
5.10.Preliminary Infiltration Evaluation..... 13
6.0 LIMITATIONS 13

LIST OF FIGURES

- Figure 1. Vicinity Map
- Figure 2. Site Plan

APPENDICES

- Appendix A. Field Explorations and Laboratory Testing
 - Figure A-1 – Key to Exploration Logs
 - Figures A-2 through A-4 – Logs of Test Pits
 - Figures A-5 and A-6 – Sieve Analysis Results
- Appendix B. Report Limitations and Guidelines for Use

1.0 INTRODUCTION AND PROJECT UNDERSTANDING

This report presents the results of our geotechnical engineering study for a portion of the overall Nisqually State Park improvement project. The subject of this report, the proposed maintenance facility, is considered Area 1 of the overall project. Our understanding of this portion of the project is based on information provided by you.

The proposed maintenance facility is to be located generally north of the intersection of Mashel Prairie Road and an un-named road, which descends downward to the southwest toward the Nisqually River. The intersection is about 1 mile southwest of the intersection between State Route 7 (SR 7) and Mashel Prairie Road. The project location is shown in the Vicinity Map, Figure 1.

The site is vacant and moderately to thickly vegetated with brush and trees. Proposed improvements include the following:

- Placement of structural fill to create a level building pad. We anticipate the fill thickness will be thinner in the southeast part of the site and thicker in the northwest part of the site, based on the site topographic information.
- Maintenance Building (65 feet long, 35 feet wide up to 30 feet high)
- Covered Storage Area, attached to maintenance building (65 feet long, 15 feet wide and about 20 feet tall)
- Ecology Block Materials Storage Bins (65 feet long, 20 feet wide, 6 feet high)
- Asphalt-concrete and crushed surfacing top course covered driveway and parking areas.

We understand that these are generally lightly loaded structures and that the maintenance building and covered storage area have large open bays. The approximate proposed location of proposed improvements is shown in Figure 2. We understand that yard surfacing will consist of crushed surfacing top course material that may be covered with asphalt concrete at some future date.

Our work was generally performed in accordance with our revised proposal, dated July 5, 2020. We received written authorization on September 1, 2020.

2.0 SCOPE OF SERVICES

The scope of services completed for this portion of the project includes the following tasks.

1. Mobilize to the site to mark exploration locations in the field. Clear publicly owned utilities at the exploration locations by contacting the One-Call utility located service.
2. Observe the completion of three test pit explorations at the locations shown in Figure 2. Test pits were advanced to depths of about 8 to 10 feet below ground surface (bgs) by Kelly's Excavating.
3. Collect two to four soil samples per test pit exploration.
4. Collect two samples from a borrow pit located approximately 1 mile northeast of the proposed Maintenance Facility area.

5. Conduct grain-size distribution analysis, including hydrometer testing, on select soil samples.
6. Characterize subsurface soil and groundwater conditions at the site based on results from our field explorations.
7. Provide recommendations for site preparation and earthwork, including clearing and stripping, temporary and permanent cut and fill slopes and our opinion of the suitability of on-site soils and soils from the borrow pit area for use as structural fill.
8. Provide recommendations for imported fill materials and for wet weather construction.
9. Comment on construction considerations, including temporary excavation support and moisture sensitivity of on-site soils.
10. Provide recommendations regarding the allowable bearing capacity and estimated settlements for the new site features.
11. Provide a recommended friction coefficient between soil and concrete.
12. Provide a range of moduli of subgrade reaction for concrete slabs.
13. Provide general opinions regarding dewatering and site drainage.
14. Provide pipe bedding recommendations and structural fill type and placement recommendations for new utilities.
15. Provide layer thickness recommendations for crushed surfacing material and asphalt concrete pavement (ACP) design sections, including subgrade preparation. Provide typical pavement sections for heavy and light traffic areas, based on our experience.
16. Provide estimated infiltration rates for selected soil samples in accordance with methods described in the 2015 Pierce County Stormwater Manual (Manual).

3.0 SURFACE CONDITIONS

The site is located on a relatively flat to undulatory upland area. Site grades are slightly undulatory, varying from about Elevation 661 feet in the northwest to about Elevation 666 feet in the southeast. The project area is currently covered in fir and alder trees and moderate to thick brush. Unimproved pathways and possibly former logging roads were visible in the site area.

3.1. Geologic Conditions

Geologic conditions at the site and nearby area were evaluated by reviewing the Washington State Department of Natural Resources “Geologic Map of the Centralia Quadrangle, Washington, 1987.” Materials mapped at and in the site area comprise Vashon Drift, Undifferentiated (map unit Qdv). This material is mapped over a broad area at and around the project site. These geologic materials are described as glacial outwash with silts, clays, lacustrine deposits and some ice contact deposits.

4.0 FIELD EXPLORATION AND LABORATORY TESTING

4.1. Field Explorations

Soil and groundwater conditions in the upland portions of the site were explored by excavating three test pits on December 1, 2020. The test pits were completed by Kelly's Excavating.

The approximate locations of the explorations completed for this project are presented on the Site Plan, Figure 2. Details of the field exploration program and logs of the explorations are presented in Appendix A, Field Explorations and Laboratory Testing.

4.2. Laboratory Testing

Soil samples obtained during our site exploration were taken to GeoEngineers' laboratory for further evaluation. Selected samples were tested for the determination of moisture content, grain-size distribution (sieve analysis) and hydrometer testing. Descriptions of the laboratory testing and the test results are presented in Appendix A.

4.3. Subsurface Conditions

Variable soil conditions was encountered in the three explorations. Approximately 6 to 12 inches of forest duff/vegetation was encountered at the ground surface in each test pit. An approximate 3- to 4-foot layer of loose to medium dense silty sand with gravel and organics was encountered below the forest duff material in pits TH-1B and TH-1C. A sample of this material from TH-1C contained about 5 percent organics, based on laboratory testing. Variable layers of silty gravel and silty sand were encountered below the surficial soil in TH-1C to 7 feet, where a hard to very hard layer of glacially consolidated lacustrine silt was encountered.

The silty sand with organic layer was absent in test pit TH-1A. Relatively clean gravel with sand (outwash) was encountered to a depth of about 4.5 feet. Medium dense silty gravel (outwash) was encountered below the clean gravel to the full depth explored. Sand with silt and gravel (outwash), was encountered beneath a surficial layer of silty sand with organic matter in TH-1B.

Boulders and cobbles were encountered in all test pits. The boulders ranged from about 2 to 3.5 feet in diameter. TH-1B met refusal on a cluster of boulders at 8 feet bgs.

4.3.1. Groundwater

Minor to moderate groundwater seepage was encountered in test pit exploration TH-1A at a depth of 9 feet. Groundwater seepage was not observed in the other test pits. We expect that future groundwater levels at the site will vary with precipitation and the depth to impermeable layers beneath the outwash material.

4.4. Borrow Pit

Two samples of surface materials were collected from the borrow pit sidewalls. The pit is relatively small with vegetated sidewalls. We observed recessional outwash sand and gravel in the north and east pit sidewalls during our site visits. We also observed what appeared to be fill in the base of the pit.

The results of grain-size analyses of the borrow pit soil samples are presented in Figure A-6. These materials appear to comprise recessional outwash, sand and gravel. Fines contents of the two samples were about 4 and 13 percent.

5.0 CONCLUSIONS AND RECOMMENDATIONS

5.1. Summary of Geotechnical Considerations

Based on our observations and the results of our subsurface exploration and testing program, it is our opinion that the site is suitable for the proposed development. A summary of the primary geotechnical considerations for the proposed maintenance facility is provided below. The summary is presented for introductory purposes only and should be used in conjunction with the detailed recommendations presented in this report.

- The near-surface silty sand and silty gravel soils contain a moderate to high percentage of fines and are sensitive to small changes in moisture content. These soils are susceptible to disturbance from construction traffic when the moisture content is more than a few percent above the optimum moisture content for compaction. These soils will be difficult, if not impossible, to work or compact when wet or if earthwork is performed in wet weather. Portions of the gravel soils contain a low to moderate percentage of fines. These soils may be suited for earthwork under wet and dry conditions. Cobbles and boulders were encountered in our explorations and should be anticipated during grading activities and site excavations.
- We recommend that the near-surface silty soils not be considered for re-use as structural fill. The relatively clean gravel soils encountered in TH-1A may be suited for use as structural fill during wet and dry weather conditions. The clean gravel soils within the borrow pit may also be suitable for fill during wet and dry weather conditions.
- We recommend all new fill placed below building, parking and driveway areas be placed and compacted as structural fill. In areas where the structural fill is to be placed, the topsoil and root mass must be removed and the existing subgrade soils should be evaluated prior to fill placement to identify soft or unsuitable soils through either probing or proof-rolling with heavy, rubber-tired construction equipment.
- The proposed structures may be satisfactorily supported on continuous and isolated shallow foundations supported on the native gravel soils or on a minimum 2-foot thickness of compacted structural fill. We recommend an allowable soil bearing pressure of 3,000 pounds per square foot (psf) for design of shallow footings.
- Floor slabs may be supported on-grade following subgrade preparation as recommended in this report. We recommend floor slabs be underlain by a minimum 18-inch thickness of on-site soils or structural fill compacted to a minimum of 95 percent of the maximum dry density (MDD) per ASTM International (ASTM) D 1557. The upper 4 inches should consist of a capillary break layer. Capillary break material should consist of well-graded sand and gravel or crushed rock that is a coarse-grained aggregate with negligible sand and silt.
- Based on the results of our subsurface explorations and laboratory testing programs only limited stormwater infiltration can be anticipated for this site based on the grain-size analyses as summarized in a subsequent section.

5.2. Site Preparation and Earthwork

5.2.1. General

Site development work will include removing existing trees and vegetation, stripping of forest duff/topsoil and root layer. The near-surface site soils are moisture sensitive due to high fines content. Grading and reuse of these soils is more practical during the dry season (typically July through September). Moisture conditioning necessary to obtain proper compaction of these soils will likely not be practical during the cooler and wetter winter months and may still present challenges during the normally dry summer months. We recommend a contingency be included in the project budget and schedule for export of unsuitable wet on-site soil and import of select granular soil if earthwork will be performed during periods of wet weather.

The following sections provide our recommendations for earthwork, site development, and fill materials.

5.2.2. Stripping and Clearing

The existing trees, shrubs, topsoil, unsuitable soils and boulders should be stripped and removed from all proposed building, parking and driveway areas. Based on our explorations, the depth of stripping to remove unsuitable surface organic materials should generally vary between 6 and 12 inches. Greater stripping depths will be required to remove localized zones of loose or organic-rich soil and tree roots or if large boulders are encountered. The primary root systems for trees and shrubs should be completely removed. Required stripping depths should be evaluated based on observations during the stripping operation. Stripped organic material should be transported off site for disposal or processed and used as fill in landscaping areas. Excavations for boulder depressions should be backfilled with structural fill compacted to the densities indicated in Section 5.4 "Fill Placement and Compaction" of this report.

5.2.3. Subgrade Evaluation

After stripping and excavation to planned subgrade is complete we recommend the exposed soil be proofrolled or probed and then compacted to a firm and unyielding condition. If dry weather conditions persist, we recommend that the subgrade be evaluated by proofrolling with a loaded dump truck or similar heavy rubber-tired construction equipment to identify soft, loose or unsuitable areas. Proofrolling must be conducted prior to placing fill. If the subgrade is prepared during or exposed to wet weather, we recommend that it be evaluated by probing with a steel probe rod.

The proofrolling/probing should be observed by a qualified geotechnical engineer, who will evaluate the suitability of the subgrade and identify any areas of yielding, which are indicative of soft or loose soil. If soft or otherwise unsuitable areas revealed during proofrolling cannot be compacted to a stable and uniformly firm condition, we recommend that: (1) the subgrade soils be scarified (e.g., with a ripper or a farmer's disc), aerated and recompact; or (2) the unsuitable soils be excavated to firm soil and replaced with structural fill, as recommended by the geotechnical engineer.

5.2.4. Excavation

Conventional earthmoving equipment in proper working order should be capable of making necessary excavations for utilities and footings. We recommend that footing and trench excavations be performed using a smooth-blade bucket to prevent excessive disturbance of the excavation base.

Boulders and large cobbles were encountered in the explorations and should be anticipated during grading and/or utility excavations. Accordingly, the contractor should be prepared to remove boulders, if

encountered. Boulders may be removed from the site or buried in landscape areas. Voids caused by boulder removal must be backfilled with structural fill.

5.2.5. Excavation Support

Shallow excavations (4 feet or less) in medium dense to dense deposits should stand at near vertical inclinations, provided groundwater seepage is not present in the cut face. Excavations deeper than 4 feet must be shored or laid back at a stable slope if workers are required to enter.

Shoring for utility excavations must conform with the provisions of Title 296 Washington Administrative Code (WAC), Part N, "Excavation, Trenching and Shoring." Regardless of the soil type encountered in the excavation, shoring, trench boxes or sloped sidewalls will be required under Washington Industrial Safety and Health Act (WISHA). While this report describes certain approaches to excavation and dewatering, the contract documents should specify that the contractor is responsible for selecting excavation and dewatering methods, monitoring the excavations for safety and providing shoring, as required, to protect personnel and adjacent structures.

5.2.6. Weather Considerations

The upper 1 to 5 feet of the native soils contain a sufficient percentage of fines (silt) to be moisture sensitive. When the moisture content of these soils is appreciably above the optimum moisture content, these soils become muddy and unstable, operation of equipment on these soils will be difficult, and it will be difficult to meet the required compaction criteria. Additionally, disturbance of these near-surface soils should be expected if earthwork is completed during periods of wet weather.

The wet weather season generally begins in early November and continues through April in Western Washington; however, periods of wet weather may occur during any month of the year. The optimum earthwork period for these types of soils is typically June through October. If wet weather earthwork is unavoidable, we recommend that:

- Structural fill placed during the wet season or during periods of wet weather consist of gravel borrow (Section 9-03.14(1) of the 2020 Washington State Department of Transportation [WSDOT] Standard Specifications) with the added restriction that no more than 5 percent of the material passing the U.S. No. 200 sieve. The unweathered recessional outwash soils encountered below a depth of about 3 to 4 feet at the site will also be suitable as well as the cleaner soils encountered in the borrow pit area.
- The ground surface in and around the work areas be sloped so that surface water is directed away from the work areas. The ground surface should be graded such that areas of ponded water do not develop. Measures should be taken by the contractor to prevent surface water from collecting in excavations and trenches. Measures should be implemented to remove surface water from the work area.

5.2.7. Erosion and Sedimentation Control

The site will be susceptible to erosion during wet weather conditions, particularly if large segments of exposed subgrades are exposed to rainfall. Development, implementation and adherence to an Erosion and Sedimentation Control Plan should reduce the project impact on erosion-prone areas. The Plan should be designed in accordance with applicable city, county and/or state standards. The Plan should incorporate basic planning principles, including:

- Scheduling grading and construction to reduce soil exposure.
- Re-vegetating or mulching denuded areas.
- Directing runoff away from exposed soils.
- Reducing the length and steepness of slopes with exposed soils.
- Decreasing runoff velocities.
- Preparing drainage ways and outlets to handle concentrated or increased runoff.
- Confining sediment to the project site.
- Inspecting and maintaining control measures frequently.

Some sloughing erosion and raveling of exposed or disturbed soil on slopes should be expected, particularly if the work is completed during the wet season. We recommend that disturbed soil be restored promptly so that surface runoff does not become channeled.

Temporary erosion protection should be used and maintained in areas with exposed or disturbed soils to help reduce erosion and transport of sediment to adjacent areas and receiving waters. Permanent erosion protection should be provided by paving, structure construction or landscape planting.

Until the permanent erosion protection is established and the site is stabilized, site monitoring may be required by qualified personnel who will evaluate the effectiveness of the erosion control measures and recommend repairs and/or modifications as appropriate. Provision for modifications to the erosion control system based on monitoring observations should be included in the Erosion and Sedimentation Control Plan.

5.3. Fill Materials

The workability of material used as structural fill depends on the gradation and moisture content of the soil. As the amount of fines (material passing the U.S. No. 200 sieve) increases, soil becomes increasingly sensitive to small changes in moisture content and adequate compaction becomes more difficult, if not impossible to achieve. As discussed previously, we recommend that select granular fill or crushed rock be used as structural fill during the rainy season. The following paragraphs summarize the material requirements for fill and backfill.

5.3.1. On-site Soils

The near-surface silty sand soils may be considered for use as structural fill during periods of extended dry weather, provided they can be properly moisture conditioned and do not contain an unacceptable amount of organic materials. The underlying clean gravel outwash soils encountered in TH-1A can likely be used as structural fill during wet and dry weather conditions. On-site materials used as structural fill must be free of roots, organic matter and other deleterious materials and particles larger than 3 inches in diameter.

5.3.2. Borrow Pit Soils

The relatively clean sand and gravel soils (Pit-2) may be considered for use as structural fill during periods of wet and dry weather. The siltier sand soils (Pit-1) may be considered for use as structural fill during

periods of extended dry weather, provided they can be properly moisture conditioned and do not contain an unacceptable amount of organic materials.

5.3.3. Select Granular Fill

Select granular fill (pit run) must consist of imported well-graded sand, sandy gravel, or crushed rock with a maximum particle size of 3 inches and less than 5 percent passing a U.S. No. 200 sieve. Organic matter, debris, or other deleterious material must not be present. Granular fill used during periods of prolonged dry weather may have up to 12 percent passing a U.S. No. 200 sieve.

5.3.4. Pipe Bedding

Trench backfill for the bedding and pipe zone must consist of well-graded granular material with a maximum particle size of $\frac{3}{4}$ inch and less than 5 percent passing the U.S. No. 200 sieve. The material must be free of roots, debris, organic matter, and other deleterious material.

5.3.5. Crushed Rock

Crushed rock fill must consist of clean, durable, crushed angular rock that has a maximum particle size of 4 inches, is well graded between coarse and fine sizes, and has less than 5 percent fines (material finer than a U.S. No. 200 sieve). A smaller maximum particle size will be required for some applications as discussed in other sections of this report. Gravel materials should be crushed to have at least two fractured faces. Organic matter, debris, or other deleterious material must not be present.

5.4. Fill Placement and Compaction

5.4.1. General

Fill soils should be compacted at a moisture content near optimum. The maximum allowable moisture content varies with the soil gradation and should be evaluated during construction. Fill and backfill material should be placed in uniform, horizontal lifts, and uniformly densified with vibratory compaction equipment. The maximum lift thickness will vary depending on the material and compaction equipment used but should generally not exceed 10 inches in loose thickness. We recommend that density testing of the placed structural fill be completed by a qualified geotechnical engineer to check that the structural fill compaction requirements presented in this report are achieved.

5.4.2. Area Fills and Bases

Fill placed to raise site grades and aggregate base materials under foundations, slabs, and parking/driveway areas should be placed on a prepared subgrade that consists of firm, inorganic native soils or compacted fill. Fill must be compacted to at least 95 percent of the MDD determined by ASTM Test Method D 1557 (modified Proctor). In pavement and crushed rock surfacing areas, the compaction criteria can be reduced to 92 percent below a depth of 2 feet from finished grade.

During wet weather or in areas that are particularly sensitive to subgrade disturbance, we recommend placing a woven geotextile between the subgrade and the first lift of fill. For this application, the first lift must comprise select granular fill. We recommend a 10-inch lift thickness and densification by static rolling for the initial lift.

5.4.3. Trench Backfill

Backfill in the bedding and pipe zone should be compacted to 90 percent of the MDD as determined by ASTM Test Method D 1557, or as recommended by the pipe manufacturer.

In nonstructural areas, trench backfill above the pipe zone should be compacted to at least 85 percent of the MDD as determined by ASTM Test Method D 1557. Suitable native soils or select granular soils should be acceptable in non-structural areas.

Within structural areas, trench backfill placed above the pipe zone must be compacted to at least 92 percent of the MDD as determined by ASTM Test Method D 1557 at depths greater than 2 feet below the finished subgrade, and to 95 percent within 2 feet of finished subgrade. Trench backfill in structural areas should consist of select granular fill or crushed rock as described in the previous sections.

5.5. Temporary and Permanent Slopes

We recommend that permanent cut and fill slopes be inclined no steeper than 2H:1V (horizontal:vertical). Flatter cut slopes may be necessary in areas where persistent groundwater seepage or zones of soft or loose soils are encountered. Temporary cut slopes should be inclined no steeper than about 1½H:1V. Surface loads should be kept at a minimum distance of at least one-half the depth of the cut away from the top of temporary slopes.

As previously stated, temporary cut slopes and shoring must comply with the provisions of Title 296 WAC, Part N, "Excavation, Trenching and Shoring." The contractor performing the work must have the primary responsibility for protection of workmen and adjacent improvements, determining whether shoring is required, and for establishing the safe inclination for open-cut slopes.

To reduce the potential for erosion, newly constructed slopes should be planted or hydroseeded shortly after completion of grading. Some sloughing and raveling of the slopes should be expected until the vegetation is established. This may require localized repairs and reseeded. Temporary covering, such as heavy plastic sheeting, jute fabric, loose straw, or excelsior matting should be used to protect unvegetated slopes during periods of rainfall.

5.6. Foundation Support

5.6.1. Shallow Foundations

The proposed building and covered storage area can be supported on continuous wall or isolated column footings established on undisturbed native outwash soils or on a minimum 2-foot thickness of structural fill. Isolated column and continuous wall footings should have minimum widths of 24 and 18 inches, respectively.

The exterior footings should be established at least 24 inches below the lowest adjacent grade for frost protection. Interior footings can be founded a minimum of 12 inches below the top of the floor slab.

5.6.2. Bearing Capacity

We recommend that footings founded as recommended be proportioned using an allowable bearing pressure of 3,000 psf. This assumes that the footings bear on the recompacted native outwash material or on a minimum 2-foot thickness of structural fill. This bearing pressure applies to the total of dead and

long-term live loads and may be increased by one-third when considering earthquake or wind loads. This is a net bearing pressure. The weight of the footing and overlying backfill can be ignored in calculating footing sizes.

5.6.3. Footing Subgrade Preparation

Footing excavations should be performed using a smooth-edged bucket to limit bearing surface disturbance. Loose or disturbed materials present at the base of footing excavations should be removed or compacted. Foundation bearing surfaces should not be exposed to standing water. If water infiltrates and pools in the excavation, it must be removed and the bearing surface reevaluated before placing structural fill or reinforcing steel.

We recommend that an experienced geotechnical engineer observe all foundation excavations before placing reinforcing steel in order to confirm that adequate bearing surfaces have been achieved and that the soil conditions are as anticipated. Unsuitable foundation subgrade soils must be removed and replaced with structural fill as recommended by the geotechnical engineer. It may be prudent to place a thin mud mat of lean concrete to protect the bearing surface if footing excavations are to remain open in wet weather.

5.6.4. Foundation Settlement

We estimate that settlements of footings designed and constructed as recommended will be less than $\frac{3}{4}$ inch, for the anticipated loading conditions. Differential settlements between comparably loaded isolated column footings or along 50 feet of continuous footing should be less than $\frac{1}{2}$ inch. Settlement is expected to occur rapidly as loads are applied.

5.6.5. Lateral Resistance

The ability of the soil to resist lateral loads is a function of frictional resistance, which can develop on the base of footings and slabs and the passive resistance, which can develop on the face of below-grade elements of the structure as these elements tend to move into the soil. For footings and floor slabs founded in accordance with the recommendations presented above, the allowable frictional resistance may be computed using a coefficient of friction of 0.35 applied to vertical dead-load forces. The allowable passive resistance on the face of footings, grade beams or other embedded foundation elements may be computed using an equivalent fluid density of 250 pounds per cubic foot (pcf) for undisturbed on-site soils or structural fill extending out from the face of the foundation element a distance at least equal to two and one-half times the depth of the element.

The passive earth pressure and friction components may be combined provided that the passive component does not exceed two-thirds of the total. The passive earth pressure value is based on the assumptions that the adjacent grade is level and that groundwater remains below the base of the footing throughout the year. The top foot of soil should be neglected when calculating passive lateral earth pressures unless the foundation area is covered with pavement or is inside a building.

The lateral resistance values include a safety factor of approximately 1.5.

5.6.6. Building Pad and Floor Slabs

A modulus of subgrade reaction of 100 pounds per cubic inch (pci) can be used for designing the building floor slab provided that the subgrade consists of structural fill that has been prepared in accordance with

Section 5.4 “Fill Placement and Compaction.” Settlements for the floor slab designed and constructed as recommended are estimated to be less than $\frac{3}{4}$ inch (approximately 300 psf). We estimate that differential settlement of the floor slabs, will be $\frac{1}{2}$ inch or less over a span of 50 feet providing that the fill below the slab is compacted as specified. The subgrade soils are non-expansive, so heave is not anticipated beneath the floor slab.

We recommend that on-grade slabs be underlain by a minimum 4-inch-thick capillary break layer to reduce the potential for moisture migration into the slab. The capillary break material should consist of a well-graded sand and gravel or crushed rock with negligible fines content. The material should be placed as recommended in Section 5.4 “Fill Placement and Compaction.”

A vapor retarder should be used as necessary to control moisture penetration through the slab. This is especially important in areas where floor coverings, adhesives or tiles are planned.

5.7. Parking and Driveway Recommendations

5.7.1. General

We understand most of the driveway and parking areas will be surfaced with crushed surfacing top course. A small section of the driveway will be covered with asphalt concrete. We understand the crushed surfacing material may be covered with asphalt concrete at some future date.

We understand that lightly loaded vehicles will generally access the site. However, we understand a semi-truck will occasionally visit the site to deliver materials. We anticipate the crushed surfacing material will bear on relatively silty soils, based on the test pit explorations.

We recommend that the section comprise 6 inches of crushed surfacing base course over 6 inches of subbase consisting of select granular fill to provide a uniform grading surface and pavement support, to maintain drainage, and to provide separation from fine-grained subgrade soil. The native subgrade should be prepared accordance with Section 5.2 “Site Preparation and Earthwork” of this report. Additional crushed rock application and fine grading should be anticipated at a later date prior to paving.

5.7.2. Asphaltic Pavement

Based on our experience with similar projects, we provide typical asphalt concrete (AC) pavement sections below. These pavement sections are typical for commercial facilities but may not be adequate for heavy construction traffic loads such as those imposed by concrete transit mixers, dump trucks or cranes or for unusual design traffic conditions. Additional pavement thickness may be necessary to prevent pavement damage during construction or if anticipated truck traffic for this facility is higher than typical. We can provide a specific design if detailed truck traffic loading information is provided. The recommended sections assume that final improvements surrounding the pavement will be designed and constructed such that stormwater or excess irrigation water from landscape areas does not accumulate below the pavement section or pond on pavement surfaces.

Pavement subgrade must be prepared as previously described. Crushed surfacing base course and subbase must be moisture conditioned to near optimum moisture content and compacted to at least 95 percent of MDD (ASTM D 1577).

Crushed surfacing base course must conform to applicable sections of 4-04 and 9-03.9(3) of the WSDOT Standard Specifications. Hot mix asphalt must conform to applicable sections of 5-04, 9-02 and 9-03 of the WSDOT Standard Specifications. PCC must conform to applicable sections of 5-05, 9-01 and 9-03 of the WSDOT Standard Specifications.

5.7.2.1. Standard-Duty ACP – Automobile Driveways and Parking Areas

- 2 inches of hot mix asphalt, class ½ inch, PG 58-22
- 4 inches of crushed surfacing base course
- 6 inches of subbase consisting of select granular fill to provide uniform grading and pavement support, to maintain drainage, and to provide separation from fine-grained subgrade soil
- Native subgrade or structural fill prepared in accordance with Section 5.2 “Site Preparation and Earthwork”

5.7.2.2. Heavy-Duty ACP – Areas Subject to Truck Traffic

- 3 inches of hot mix asphalt, class ½ inch, PG 58-22
- 6 inches of crushed surfacing base course
- 6 inches of subbase consisting of select granular fill to provide a uniform grading surface and pavement support, to maintain drainage, and to provide separation from fine-grained subgrade soil
- Native subgrade or structural fill prepared accordance with Section 5.2 “Site Preparation and Earthwork”

5.8. Seismic Design Parameters

We recommend the use of the following 2018 International Building Code (IBC) parameters for seismic design:

TABLE 1. SEISMIC DESIGN PARAMETERS

2018 IBC (ASCE 7-16) Seismic Design Parameters	
Spectral Response Acceleration at Short Periods (S_s)	1.188g
Spectral Response Acceleration at 1-Second Periods (S_1)	0.424g
Site Class	D
Design Peak Ground Acceleration (PGA_M)	0.55g
Design Spectral Response Acceleration at Short Periods (S_{DS})	0.811g
Design Spectral Response Acceleration at 1-Second Periods (S_{D1})	null ¹

¹ A ground motion hazard analysis may be required in accordance with Section 11.4.8 of ASCE 7-16.

5.9. Liquefaction Potential

Liquefaction refers to a condition where vibration or shaking of the ground, usually from earthquake forces, results in development of excess pore pressures in loose, saturated soils and subsequent loss of strength in the deposit of soil so affected. In general, soils that are susceptible to liquefaction include loose to medium dense “clean” to silty sands that are below the water table. Based on the conditions in our explorations, there is the potential for some of the sand outwash soils to experience liquefaction. However,

based on the relatively shallow depth to glacially consolidated soils and depth to groundwater encountered in our explorations, it is our opinion the risk of liquefaction is low at the site.

5.10. Preliminary Infiltration Evaluation

We evaluated the preliminary infiltration potential of select samples of soils encountered in our test pits by estimating design infiltration rates using criteria provided in the Method 2, Appendix III-A of the 2015 Manual.

TABLE 2. ESTIMATED PRELIMINARY SOIL INFILTRATION RATES¹

Test Pit No.	Soil Sample No.	Soil Sample Depth (feet)	Percent Fines ²	Percent Gravel and Coarse Sand ³	Estimated Preliminary Design Infiltration Rate (inches/hour) ⁴
TH-1A	2	5	5	65	2
TP-1A	3	9	15	68	0.5
TH-1B	2	4.5	12	42	0.5
TP-1C	3	5.5	15	36	0.5

Notes:

- ¹ For selected soil samples.
- ² Defined as particles passing the No. 200 sieve.
- ³ Defined as particles retained on the No. 10 sieve.
- ⁴ Derived by Method 2 within Appendix III-A of the 2015 Pierce County Stormwater Manual.

Based on our evaluation, the test pit results and our experience, it is our opinion that only limited stormwater infiltration is possible at the site. Most of the soils encountered have preliminary infiltration rates less than 1 inch per hour. Variable soil conditions were encountered across the site and groundwater was encountered at a depth of 9 feet in test pit TH-1C. Since slow infiltration is expected, we recommend that the infiltration facilities be designed to infiltration stormwater over a relatively wide area.

6.0 LIMITATIONS

We have prepared this report for use by Robert W. Droll, Landscape Architects. This report may be made available to regulatory agencies. Our analysis, interpretations and conclusions should not be construed as a warranty of subsurface conditions beneath the site. We have relied on information prepared and supplied by others in developing our recommendations. GeoEngineers makes no representations as to the accuracy or reliability of these data.

Within the limitations of scope, schedule and budget, our services have been executed in accordance with generally accepted practices in the field of geotechnical engineering in this area at the time this report was prepared. The conclusions, recommendations, and opinions presented in this report are based on our professional knowledge, judgment and experience. No warranty or other conditions, express or implied, should be understood.

Please refer to Appendix B titled “Report Limitations and Guidelines for Use” for additional information pertaining to use of this report.



P:\2\2935067\GIS\2935067_Project\2935067_Project.aprx 293506700_F01_VicinityMap Date Exported: 12/10/20 by maugust

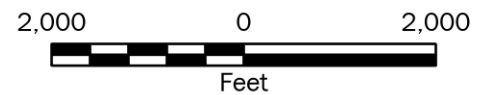
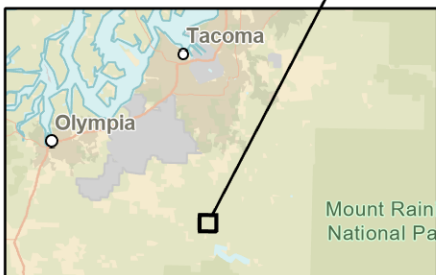

Vicinity Map

Proposed Maintenance Building - Nisqually State Park
Pierce County, Washington



Figure 1

Notes:

1. The locations of all features shown are approximate.
2. This drawing is for information purposes. It is intended to assist in showing features discussed in an attached document. GeoEngineers, Inc. cannot guarantee the accuracy and content of electronic files. The master file is stored by GeoEngineers, Inc. and will serve as the official record of this communication.

Data Source: ESRI

Projection: NAD 1983 StatePlane Washington North FIPS 4601 Feet

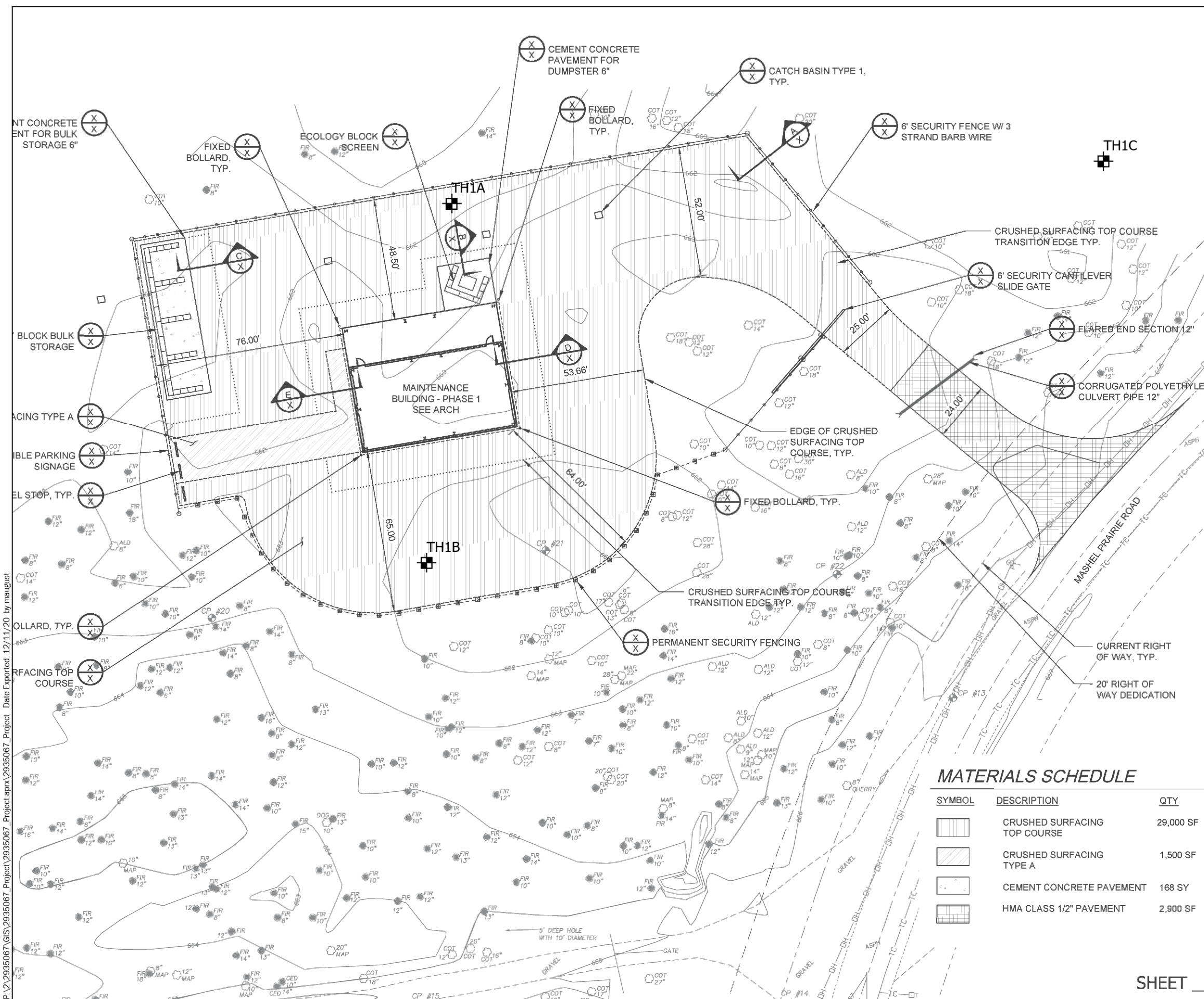

Legend

☒ Approximate Location of Test Pit

Notes:

1. The locations of all features shown are approximate.
2. This drawing is for information purposes. It is intended to assist in showing features discussed in an attached document. GeoEngineers, Inc. cannot guarantee the accuracy and content of electronic files. The master file is stored by GeoEngineers, Inc. and will serve as the official record of this communication.

Data Source: 12-11-20 NSP Area 1 Survey, September 2020.

Projection: NAD 1983 StatePlane Washington South FIPS 4602 Feet

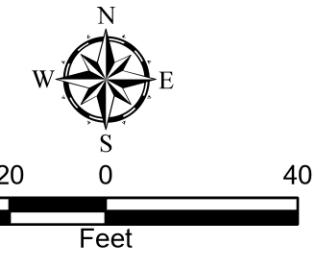

MATERIALS SCHEDULE

SYMBOL	DESCRIPTION	QTY
	CRUSHED SURFACING TOP COURSE	29,000 SF
	CRUSHED SURFACING TYPE A	1,500 SF
	CEMENT CONCRETE PAVEMENT	168 SY
	HMA CLASS 1/2" PAVEMENT	2,900 SF

Site Plan

Proposed Maintenance Building - Nisqually State Park
Pierce County, Washington

GEOENGINEERS

Figure 2

P:\2935067\GIS\2935067_Project.aprx\2935067_Project.aprx Date Exported: 12/11/20 by maugust

SHEET

APPENDIX A
Field Explorations and Laboratory Testing

APPENDIX A FIELD EXPLORATIONS AND LABORATORY TESTING

Field Explorations

Soil and groundwater conditions were explored at the site by observing and collecting soil samples in three test pit explorations completed by Kelly's Excavating on December 1, 2020. Explorations were completed to depths ranging from 8 to 10 feet each. Exploration locations should be considered approximate and are shown on the Site Plan, Figure 2.

Test pits were continuously monitored by our representative who maintained a log of subsurface conditions, visually classified the soils encountered, and obtained representative soil samples. Soils encountered were visually classified in general accordance with the classification system described in Figure A-1. Test pit logs are presented in Figures A-2 through A-4. The logs are based on our interpretation of the field and laboratory data and indicate the various types of soils encountered. They also indicate the depths at which the soil characteristics change, although the change might actually be gradual. The ground surface elevations shown on the logs are based on topographic information provided by Robert Droll Landscape Architects.

Laboratory Testing

Soil samples obtained from the explorations were brought to our laboratory to confirm field classifications. Selected samples were tested to determine their moisture content and grain-size distribution in general accordance with applicable ASTM International (ASTM) standards.

The moisture content of selected samples was determined in general accordance with ASTM Test Method D 2216. The test results are presented in the respective test pit logs in Appendix A. Grain-size distribution (sieve analyses) and hydrometer testing were conducted in general accordance with ASTM Test Method D 422. The results of the grain-size and hydrometer analyses are presented in Figures A-5 and A-6.

SOIL CLASSIFICATION CHART

MAJOR DIVISIONS			SYMBOLS		TYPICAL DESCRIPTIONS
			GRAPH	LETTER	
COARSE GRAINED SOILS	GRAVEL AND GRAVELLY SOILS	CLEAN GRAVELS <small>(LITTLE OR NO FINES)</small>		GW	WELL-GRADED GRAVELS, GRAVEL - SAND MIXTURES
		GRAVELS WITH FINES <small>(APPRECIABLE AMOUNT OF FINES)</small>		GP	POORLY-GRADED GRAVELS, GRAVEL - SAND MIXTURES
		GRAVELS WITH FINES <small>(APPRECIABLE AMOUNT OF FINES)</small>		GM	SILTY GRAVELS, GRAVEL - SAND - SILT MIXTURES
	SAND AND SANDY SOILS	CLEAN SANDS <small>(LITTLE OR NO FINES)</small>		SW	WELL-GRADED SANDS, GRAVELLY SANDS
		SANDS WITH FINES <small>(APPRECIABLE AMOUNT OF FINES)</small>		SP	POORLY-GRADED SANDS, GRAVELLY SAND
		SANDS WITH FINES <small>(APPRECIABLE AMOUNT OF FINES)</small>		SM	SILTY SANDS, SAND - SILT MIXTURES
FINE GRAINED SOILS	SILTS AND CLAYS	LIQUID LIMIT LESS THAN 50		ML	INORGANIC SILTS, ROCK FLOUR, CLAYEY SILTS WITH SLIGHT PLASTICITY
		LIQUID LIMIT LESS THAN 50		CL	INORGANIC CLAYS OF LOW TO MEDIUM PLASTICITY, GRAVELLY CLAYS, SANDY CLAYS, SILTY CLAYS, LEAN CLAYS
		LIQUID LIMIT LESS THAN 50		OL	ORGANIC SILTS AND ORGANIC SILTY CLAYS OF LOW PLASTICITY
	SILTS AND CLAYS	LIQUID LIMIT GREATER THAN 50		MH	INORGANIC SILTS, MICACEOUS OR DIATOMACEOUS SILTY SOILS
		LIQUID LIMIT GREATER THAN 50		CH	INORGANIC CLAYS OF HIGH PLASTICITY
		LIQUID LIMIT GREATER THAN 50		OH	ORGANIC CLAYS AND SILTS OF MEDIUM TO HIGH PLASTICITY
HIGHLY ORGANIC SOILS			PT	PEAT, HUMUS, SWAMP SOILS WITH HIGH ORGANIC CONTENTS	

NOTE: Multiple symbols are used to indicate borderline or dual soil classifications

Sampler Symbol Descriptions

	2.4-inch I.D. split barrel
	Standard Penetration Test (SPT)
	Shelby tube
	Piston
	Direct-Push
	Bulk or grab
	Continuous Coring

Blowcount is recorded for driven samplers as the number of blows required to advance sampler 12 inches (or distance noted). See exploration log for hammer weight and drop.

"P" indicates sampler pushed using the weight of the drill rig.

"WOH" indicates sampler pushed using the weight of the hammer.

NOTE: The reader must refer to the discussion in the report text and the logs of explorations for a proper understanding of subsurface conditions. Descriptions on the logs apply only at the specific exploration locations and at the time the explorations were made; they are not warranted to be representative of subsurface conditions at other locations or times.

ADDITIONAL MATERIAL SYMBOLS

SYMBOLS		TYPICAL DESCRIPTIONS
GRAPH	LETTER	
	AC	Asphalt Concrete
	CC	Cement Concrete
	CR	Crushed Rock/Quarry Spalls
	SOD	Sod/Forest Duff
	TS	Topsoil

Groundwater Contact



Measured groundwater level in exploration, well, or piezometer



Measured free product in well or piezometer

Graphic Log Contact



Distinct contact between soil strata



Approximate contact between soil strata

Material Description Contact



Contact between geologic units



Contact between soil of the same geologic unit

Laboratory / Field Tests

%F	Percent fines
%G	Percent gravel
AL	Atterberg limits
CA	Chemical analysis
CP	Laboratory compaction test
CS	Consolidation test
DD	Dry density
DS	Direct shear
HA	Hydrometer analysis
MC	Moisture content
MD	Moisture content and dry density
Mohs	Mohs hardness scale
OC	Organic content
PM	Permeability or hydraulic conductivity
PI	Plasticity index
PL	Point load test
PP	Pocket penetrometer
SA	Sieve analysis
TX	Triaxial compression
UC	Unconfined compression
VS	Vane shear

Sheen Classification

NS	No Visible Sheen
SS	Slight Sheen
MS	Moderate Sheen
HS	Heavy Sheen

Key to Exploration Logs



Figure A-1

Date Excavated	12/1/2020	Total Depth (ft)	10	Logged By	SLG	Excavator	Kelly's Excavating	See "Remarks" section for groundwater observed Caving not observed
Checked By	SWH	Equipment	Takeuchi TB138					
Surface Elevation (ft) Vertical Datum	662			Easting (X) Northing (Y)	1179575.94 560428.88		Coordinate System Horizontal Datum	

Elevation (feet)	Depth (feet)	SAMPLE		Graphic Log	Group Classification	MATERIAL DESCRIPTION	Moisture Content (%)	Fines Content (%)	REMARKS
		Testing Sample	Sample Name Testing						
661	1				TS	Vegetation/topsoil (loose, dry to moist)			Numerous cobbles and occasional boulders encountered from 1 to 9 feet bgs
660	2		SA		GP	Brown gravel with sand, cobbles and occasional boulders (medium dense, moist)	5	5	
660	3				GM	Gray silty gravel with sand (medium dense, moist to wet) (outwash)			
660	4				GM	Gray silty gravel with sand (medium dense, moist to wet) (outwash)			
660	5		2						
660	6								
660	7								
660	8								
660	9		SA				18	17	Minor to moderate groundwater seepage observed at 9 feet bgs
660	10								

Notes: See Figure A-1 for explanation of symbols.
The depths on the test pit logs are based on an average of measurements across the test pit and should be considered accurate to 1/2 foot.
Coordinates Data Source: Horizontal approximated based on . Vertical approximated based on .



Log of Test Pit TH-1A



Project: Proposed Maintenance Facility Nisqually State Park
Project Location: Pierce County, Washington
Project Number: 2935-067-00

Date: 12/1/20 Path: P:\2935067\GINT\2935067\00.GPJ DBLlibrary\Library\GEOENGINEERS_DF_STD_US_JUNE_2017.GLB\GER_TESTPIT_1P_GEOTEC_MF

Date Excavated	12/1/2020	Total Depth (ft)	8	Logged By	SLG	Excavator	Kelly's Excavating	Groundwater not observed
				Checked By	SWH	Equipment	Takeuchi TB138	Caving not observed
Surface Elevation (ft) Vertical Datum	664			Easting (X) Northing (Y)	1179565.89 560254.63		Coordinate System Horizontal Datum	

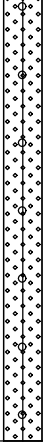
Elevation (feet)	Depth (feet)	SAMPLE		Graphic Log	Group Classification	MATERIAL DESCRIPTION	Moisture Content (%)	Fines Content (%)	REMARKS
		Testing Sample	Sample Name Testing						
					DUFF	Forest duff			
663	1				SM	Brown silty sand with gravel and organic matter (loose to medium dense, moist)	20	20	
662	2		g14						
661	3								
660	4								
659	5		g13		SW-SM	Brown sand with silt and gravel (medium dense, moist) (outwash)	10	12	
658	6								
657	7								
656	8								Refusal at 8 feet on boulders

Notes: See Figure A-1 for explanation of symbols.
 The depths on the test pit logs are based on an average of measurements across the test pit and should be considered accurate to 1/2 foot.
 Coordinates Data Source: Horizontal approximated based on . Vertical approximated based on .

Log of Test Pit TH-1B



Project: Proposed Maintenance Facility Nisqually State Park
 Project Location: Pierce County, Washington
 Project Number: 2935-067-00

Figure A-3
 Sheet 1 of 1

Date: 12/1/20 Path: P:\2935067\GINT\293506700.GPJ DBLibrary\Library\GEOENGINEERS_DF_STD_US_JUNE_2017.GLB\GERB_TESTPIT_IP_GEOtec_MF

Date Excavated	12/1/2020	Total Depth (ft)	9	Logged By	SLG	Excavator	Kelly's Excavating	Groundwater not observed
				Checked By	SWH	Equipment	Takeuchi TB138	Caving not observed
Surface Elevation (ft) Vertical Datum	662			Easting (X) Northing (Y)	1179837.3 560445.85		Coordinate System Horizontal Datum	

Elevation (feet)	Depth (feet)	SAMPLE		Graphic Log	Group Classification	MATERIAL DESCRIPTION	Moisture Content (%)	Fines Content (%)	REMARKS
		Testing Sample	Sample Name Testing						
					DUFF	Forest duff			
661	1				SM	Brown silty sand with gravel and organic matter (loose to medium dense, moist to wet)			
660	2		MC		SM	Brown silty sand with gravel and organic matter (loose to medium dense, moist to wet)	24		4.6 percent organics 2 to 3 feet picked up numerous cobbles and boulders
659	3				GM	Brown silty gravel with sand, cobbles and occasional boulders (medium dense, moist to wet) (outwash)			
658	4		GM		GM	Brown silty gravel with sand, cobbles and occasional boulders (medium dense, moist to wet) (outwash)	11	20	
657	5				SM	Brown silty sand with occasional gravel (medium dense, moist) (outwash)			
656	6		SM		SM	Brown silty sand with occasional gravel (medium dense, moist) (outwash)	15	15	
655	7				ML	Gray-tan red mottled silt with sand (hard to very hard, moist) (glaciolacustrine)			
654	8		4		ML	Gray-tan red mottled silt with sand (hard to very hard, moist) (glaciolacustrine)			Denser digging at approximately 8½ feet per operator
653	9								

Notes: See Figure A-1 for explanation of symbols.
The depths on the test pit logs are based on an average of measurements across the test pit and should be considered accurate to ½ foot.
Coordinates Data Source: Horizontal approximated based on . Vertical approximated based on .

Log of Test Pit TH-1C



Project: Proposed Maintenance Facility Nisqually State Park
Project Location: Pierce County, Washington
Project Number: 2935-067-00

Figure A-4
Sheet 1 of 1

Date: 12/1/20 Path: P:\2935067\GINT\2935067\00.GPJ DBLlibrary\Library\GEOENGINEERS_DF STD_US_JUNE_2017.GLB\GERB_TESTPIT_IP_GEOtec_SF

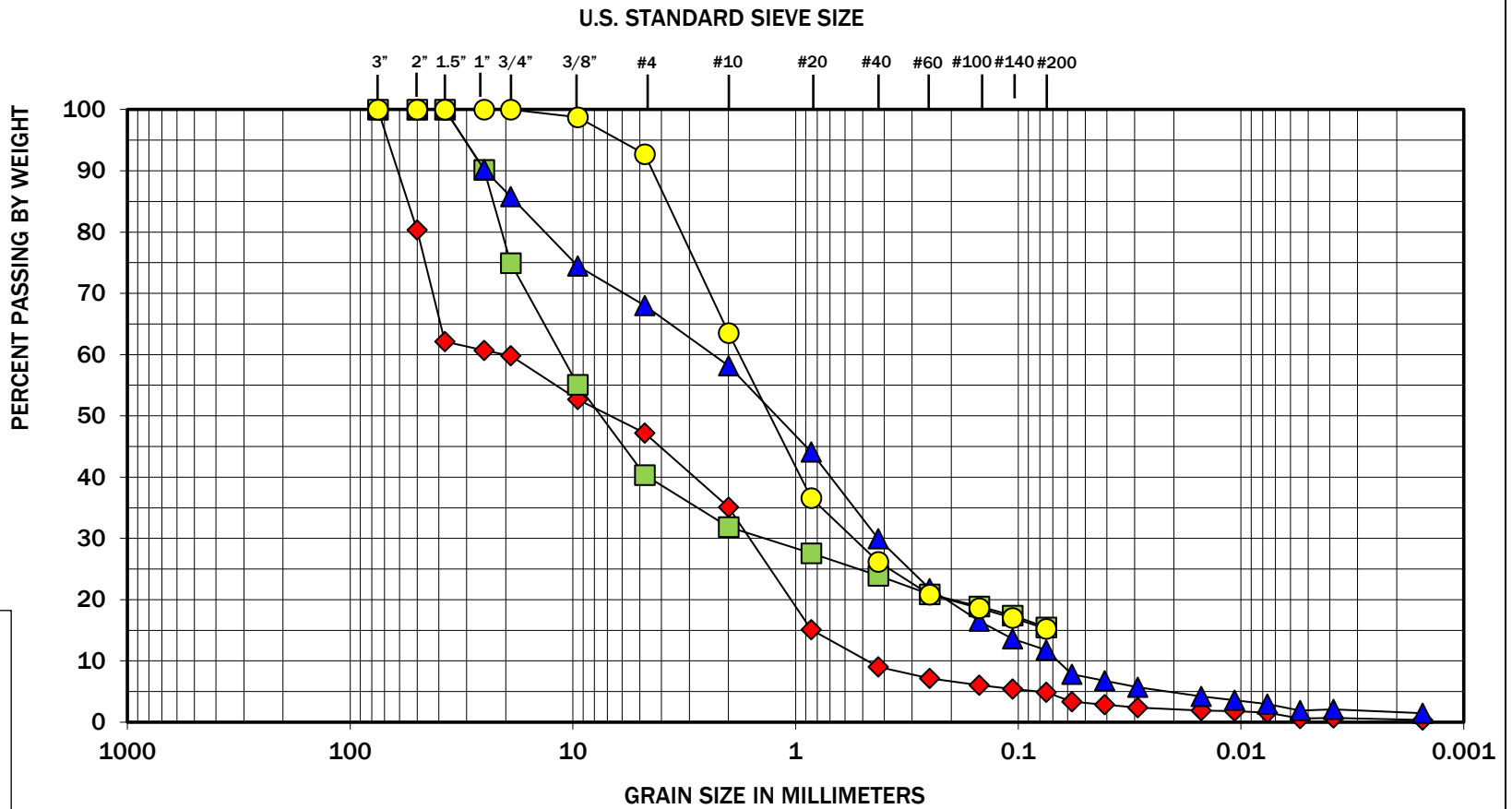

COBBLES	GRAVEL		SAND			SILT OR CLAY
	COARSE	FINE	COARSE	MEDIUM	FINE	

Symbol	Exploration Number	Depth (feet)	Moisture (%)	Soil Description
◆	TH-1A	5	5	Gravel with sand (GP)
■	TH-1A	9	18	Silty gravel with sand (GM)
▲	TH-1B	4.5	10	Sand with silt and gravel (SW-SM)
●	TH-1C	5.5	15	Silty sand (SM)



Note: This report may not be reproduced, except in full, without written approval of GeoEngineers, Inc. Test results are applicable only to the specific sample on which they were performed, and should not be interpreted as representative of any other samples obtained at other times, depths or locations, or generated by separate operations or processes.

The grain size analysis results were obtained in general accordance with ASTM C 136. GeoEngineers 17425 NE Union Hill Road Ste 250, Redmond, WA 98052

GEOENGINEERS
 Proposed Maintenance Building - Nisqually Park
 Pierce County, Washington
Sieve Analysis Results
Figure A-5

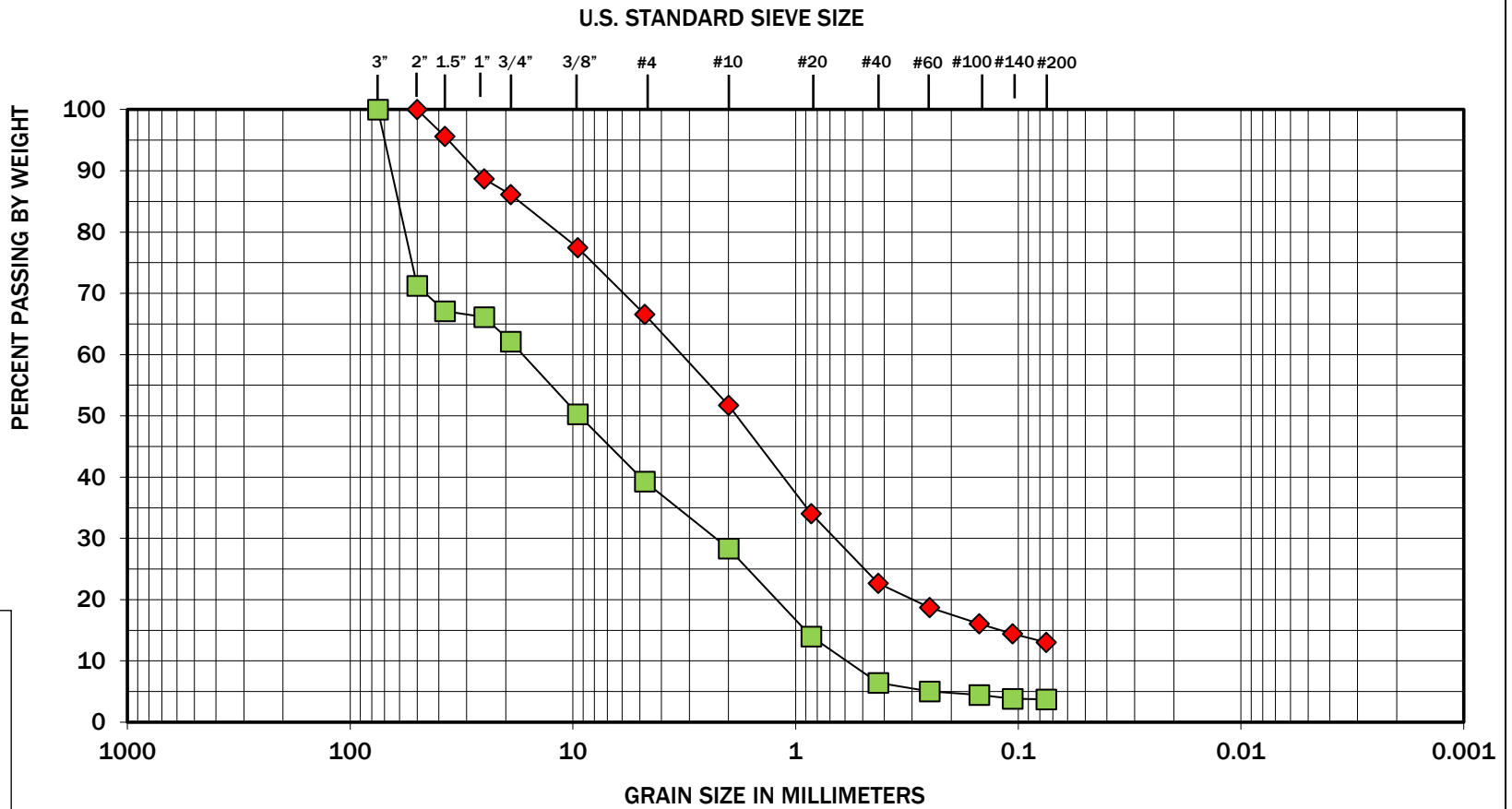

APPENDIX B
Report Limitations and Guidelines for Use

APPENDIX B REPORT LIMITATIONS AND GUIDELINES FOR USE¹

This appendix provides information to help you manage your risks with respect to the use of this report.

Geotechnical Services Are Performed For Specific Purposes, Persons and Projects

This report has been prepared for the exclusive use of Robert Droll Landscape Architects and their authorized agents. This report is not intended for use by others, and the information contained herein is not applicable to other sites.

GeoEngineers structures our services to meet the specific needs of our clients. For example, a geotechnical or geologic study conducted for a civil engineer or architect may not fulfill the needs of a construction contractor or even another civil engineer or architect that are involved in the same project. Because each geotechnical or geologic study is unique, each geotechnical engineering or geologic report is unique, prepared solely for the specific client and project site. Our report is prepared for the exclusive use of our Client. No other party may rely on the product of our services unless we agree in advance to such reliance in writing. This is to provide our firm with reasonable protection against open-ended liability claims by third parties with whom there would otherwise be no contractual limits to their actions. Within the limitations of scope, schedule and budget, our services have been executed in accordance with our Agreement with the Client and generally accepted geotechnical practices in this area at the time this report was prepared. This report should not be applied for any purpose or project except the one originally contemplated.

A Geotechnical Engineering or Geologic Report is Based on a Unique Set of Project-Specific Factors

This report has been prepared for the planned Maintenance Facility improvements at Nisqually State Park in Pierce County, Washington. GeoEngineers considered a number of unique, project-specific factors when establishing the scope of services for this project and report. Unless GeoEngineers specifically indicates otherwise, do not rely on this report if it was:

- not prepared for you,
- not prepared for your project,
- not prepared for the specific site explored, or
- completed before important project changes were made.

For example, changes that can affect the applicability of this report include those that affect:

- the function of the proposed structure;
- elevation, configuration, location, orientation or weight of the proposed structure;
- composition of the design team; or
- project ownership.

¹ Developed based on material provided by ASFE, Professional Firms Practicing in the Geosciences; www.asfe.org.

If important changes are made after the date of this report, GeoEngineers should be given the opportunity to review our interpretations and recommendations and provide written modifications or confirmation, as appropriate.

Subsurface Conditions Can Change

This report is based on conditions that existed at the time the study was performed. The findings and conclusions of this report may be affected by the passage of time, by manmade events such as construction on or adjacent to the site, or by natural events such as floods, earthquakes, slope instability or groundwater fluctuations. Always contact GeoEngineers before applying a report to determine if it remains applicable.

Most Geotechnical and Geologic Findings are Professional Opinions

Our interpretations of subsurface conditions are based on field observations from widely spaced sampling locations at the site. Site exploration identifies subsurface conditions only at those points where subsurface tests are conducted or samples are taken. GeoEngineers reviewed field and laboratory data and then applied our professional judgment to render an opinion about subsurface conditions throughout the site. Actual subsurface conditions may differ, sometimes significantly, from those indicated in this report. Our report, conclusions and interpretations should not be construed as a warranty of the subsurface conditions.

Geotechnical Engineering Report Recommendations are Not Final

Do not over-rely on the preliminary construction recommendations included in this report. These recommendations are not final, because they were developed principally from GeoEngineers' professional judgment and opinion. GeoEngineers' recommendations can be finalized only by observing actual subsurface conditions revealed during construction. GeoEngineers cannot assume responsibility or liability for this report's recommendations if we do not perform construction observation.

Sufficient monitoring, testing and consultation by GeoEngineers should be provided during construction to confirm that the conditions encountered are consistent with those indicated by the explorations, to provide recommendations for design changes should the conditions revealed during the work differ from those anticipated, and to evaluate whether or not earthwork activities are completed in accordance with our recommendations. Retaining GeoEngineers for construction observation for this project is the most effective method of managing the risks associated with unanticipated conditions.

A Geotechnical Engineering or Geologic Report Could be Subject to Misinterpretation

Misinterpretation of this report by other design team members can result in costly problems. You could lower that risk by having GeoEngineers confer with appropriate members of the design team after submitting the report. Also retain GeoEngineers to review pertinent elements of the design team's plans and specifications. Contractors can also misinterpret a geotechnical engineering or geologic report. Reduce that risk by having GeoEngineers participate in pre-bid and preconstruction conferences, and by providing construction observation.

Do Not Redraw the Exploration Logs

Geotechnical engineers and geologists prepare final boring and testing logs based upon their interpretation of field logs and laboratory data. To prevent errors or omissions, the logs included in a geotechnical engineering or geologic report should never be redrawn for inclusion in architectural or other design

drawings. Only photographic or electronic reproduction is acceptable, but recognize that separating logs from the report can elevate risk.

Give Contractors a Complete Report and Guidance

Some owners and design professionals believe they can make contractors liable for unanticipated subsurface conditions by limiting what they provide for bid preparation. To help prevent costly problems, give contractors the complete geotechnical engineering or geologic report, but preface it with a clearly written letter of transmittal. In that letter, advise contractors that the report was not prepared for purposes of bid development and that the report's accuracy is limited; encourage them to confer with GeoEngineers and/or to conduct additional study to obtain the specific types of information they need or prefer. A pre-bid conference can also be valuable. Be sure contractors have sufficient time to perform additional study. Only then might an owner be in a position to give contractors the best information available, while requiring them to at least share the financial responsibilities stemming from unanticipated conditions. Further, a contingency for unanticipated conditions should be included in your project budget and schedule.

Contractors are Responsible for Site Safety on Their Own Construction Projects

Our geotechnical recommendations are not intended to direct the contractor's procedures, methods, schedule or management of the work site. The contractor is solely responsible for job site safety and for managing construction operations to minimize risks to on-site personnel and to adjacent properties.

Read These Provisions Closely

Some clients, design professionals and contractors may not recognize that the geoscience practices (geotechnical engineering or geology) are far less exact than other engineering and natural science disciplines. This lack of understanding can create unrealistic expectations that could lead to disappointments, claims and disputes. GeoEngineers includes these explanatory "limitations" provisions in our reports to help reduce such risks. Please confer with GeoEngineers if you are unclear how these "Report Limitations and Guidelines for Use" apply to your project or site.

Geotechnical, Geologic and Environmental Reports Should Not be Interchanged

The equipment, techniques and personnel used to perform an environmental study differ significantly from those used to perform a geotechnical or geologic study and vice versa. For that reason, a geotechnical engineering or geologic report does not usually relate any environmental findings, conclusions or recommendations; e.g., about the likelihood of encountering underground storage tanks or regulated contaminants. Similarly, environmental reports are not used to address geotechnical or geologic concerns regarding a specific project.

Biological Pollutants

GeoEngineers' Scope of Work specifically excludes the investigation, detection, prevention, or assessment of the presence of Biological Pollutants in or around any structure. Accordingly, this report includes no interpretations, recommendations, findings, or conclusions for the purpose of detecting, preventing, assessing, or abating Biological Pollutants and no conclusions or inferences should be drawn regarding Biological Pollutants, as they may relate to this project. The term "Biological Pollutants" includes, but is not limited to, molds, fungi, spores, bacteria, and viruses, and/or any of their byproducts. If Client desires these specialized services, they should be obtained from a consultant who offers services in this specialized field.

Geotechnical Engineering Services Report

Area 4
Proposed Nisqually Access Area
Nisqually State Park
Pierce County, Washington

for
Robert W. Droll, Landscape Architects

March 5, 2021



Geotechnical Engineering Services Report

Area 4
Proposed Nisqually Access Area
Nisqually State Park
Pierce County, Washington

for

Robert W. Droll, Landscape Architects

March 5, 2021



1101 South Fawcett Avenue, Suite 200
Tacoma, Washington 98402
253.383.4940

Geotechnical Engineering Services Report

Area 4

Proposed Nisqually Access Area Nisqually State Park Pierce County, Washington

File No. 2935-067-00

March 5, 2021

Prepared for:

Robert W. Droll, Landscape Architects
4405 7th Avenue SE
Lacey, Washington 98503

Attention: Bob Droll

Prepared by:

GeoEngineers, Inc.
1101 South Fawcett Avenue, Suite 200
Tacoma, Washington 98402
253.383.4940

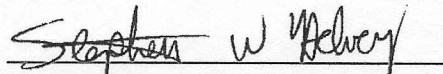

Stephen W. Helvey, LG, LEG, LHG
Senior Engineering Geologist

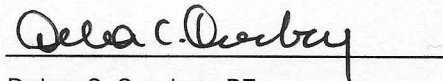

Debra C. Overbay, PE
Associate



SWH:DCO:tt:ch

Disclaimer: Any electronic form, facsimile or hard copy of the original document (email, text, table, and/or figure), if provided, and any attachments are only a copy of the original document. The original document is stored by GeoEngineers, Inc. and will serve as the official document of record.

Table of Contents

1.0 INTRODUCTION AND PROJECT UNDERSTANDING.....	1
2.0 SCOPE OF SERVICES.....	1
3.0 SURFACE CONDITIONS.....	2
3.1. Geologic Conditions.....	3
4.0 FIELD EXPLORATIONS AND LABORATORY TESTING.....	3
4.1. Field Explorations.....	3
4.2. Laboratory Testing.....	3
4.3. Subsurface Conditions.....	3
4.3.1. Plateau.....	3
4.3.2. Ohop Valley.....	3
4.3.3. Groundwater.....	4
5.0 CONCLUSIONS AND RECOMMENDATIONS.....	4
5.1. Summary of Geotechnical Considerations.....	4
5.2. Site Preparation and Earthwork.....	5
5.2.1. General.....	5
5.2.2. Stripping and Clearing.....	5
5.2.3. Subgrade Evaluation.....	5
5.2.4. Excavation.....	6
5.2.5. Excavation Support.....	6
5.2.6. Weather Considerations.....	6
5.2.7. Erosion and Sedimentation Control.....	7
5.3. Fill Materials.....	7
5.3.1. On-site Soils.....	7
5.3.2. Borrow Pit Soils.....	8
5.3.3. Select Granular Fill.....	8
5.3.4. Pipe Bedding.....	8
5.3.5. Crushed Rock.....	8
5.4. Fill Placement and Compaction.....	8
5.4.1. General.....	8
5.4.2. Area Fills and Bases.....	8
5.4.3. Trench Backfill.....	9
5.5. Temporary and Permanent Slopes.....	9
5.6. Foundation Support.....	9
5.6.1. Shallow Foundations.....	9
5.6.2. Bearing Capacity.....	10
5.6.3. Footing Subgrade Preparation.....	10
5.6.4. Foundation Settlement.....	10
5.6.5. Lateral Resistance.....	10
5.6.6. Building Pads and Floor Slabs.....	11
5.7. Overlooks and Boardwalks.....	11
5.7.1. General.....	11
5.7.2. Pier Mat Foundations.....	11

5.8. Pin Piles	12
5.9. Helical Piers/Piles.....	13
5.10. Parking, Driveway and Access Road Recommendations	13
5.10.1. General.....	13
5.10.2. Asphaltic Pavement.....	13
5.11. Preliminary Infiltration Evaluation.....	14
6.0 LIMITATIONS	15

LIST OF FIGURES

- Figure 1. Vicinity Map
- Figure 2. Site Plan

APPENDICES

- Appendix A. Field Explorations and Laboratory Testing
 - Figure A-1 – Key to Exploration Logs
 - Figures A-2 through A-6 – Logs of Test Pits
 - Figures A-7 and A-8 – Sieve Analysis Results
- Appendix B. Report Limitations and Guidelines for Use

1.0 INTRODUCTION AND PROJECT UNDERSTANDING

This report presents the results of our geotechnical engineering study for a portion of the Nisqually State Park improvement project. The subject of this report, the proposed Nisqually Access Area, is considered Area 4 of the overall Park Site. Our understanding of this portion of the project is based on information provided by you and our previous work in other areas of Nisqually Park.

Area 4 generally lies in the northwest portion of the overall Nisqually Park site. Features in this area include the Ohop Creek Valley, the Nisqually River, the south Ohop Creek Valley Wall and an upland plateau southeast of the Ohop Valley. We understand that most of the Nisqually Park site is located within the plateau area. Most of the proposed Area 4 improvements are located within the Ohop Creek Valley. The approximate location of features investigated as a part of this portion of the project is shown in the Vicinity Map, Figure 1.

We understand that Area 4 improvements include the following:

- Converting an existing gravel-soil surfaced roadway to a one-laned asphalt-concrete paved roadway. This feature is about 8,000 feet long.
- Non-Motorized Boat Trailer and Bus Parking Area. This feature is to be located on the southeast side of the new roadway, approximately 4,000 feet from the intersection of the unimproved roadway and Mashel Prairie Road. This area is in an upland plateau and will comprise asphalt-concrete paved parking stalls.
- Nisqually River Access Parking Area. This feature is to be located within the Ohop Valley, just east of the unimproved access road. This area will include asphalt-concrete paved driveway and parking areas and possibly a small one-story structure.
- Nisqually Overlook. This feature is located within the Ohop Valley, west of the unimproved access road. We understand this feature will be a short, pile- or pier-supported overlook structure near the Nisqually River.
- Ohop Creek Overlooks and Boardwalk. These features are located generally north of the unimproved access road and will comprise short pile- or pier-supported overlook and boardwalk structures.

The approximate location of these structures is shown in Figure 2. Preliminary design drawings for these features were not available at the time of this report.

Our work was generally performed in accordance with our revised proposal, dated July 5, 2020. We received written authorization on September 1, 2020.

2.0 SCOPE OF SERVICES

The scope of services completed for this portion of the project includes the following tasks.

1. Mobilize to the site to mark exploration locations in the field. Clear publicly owned utilities at the exploration locations by contacting the One-Call utility located service.

2. Observe the completion of five test pit explorations at the locations shown in Figure 2. Test pits were advanced to depths of about 8 to 14 feet below ground surface (bgs) by Kelly's Excavating.
3. Collect two to four soil samples per test pit exploration.
4. Conduct grain-size distribution and hydrometer analysis on select soil samples.
5. Characterize subsurface soil and groundwater conditions at the site based on results from our field explorations.
6. Provide recommendations for site preparation and earthwork, including clearing and stripping, temporary and permanent cut and fill slopes and our opinion of the suitability of on-site soils and soils from the borrow pit area for use as structural fill.
7. Provide recommendations for imported fill materials and for wet weather construction.
8. Comment on construction considerations, including temporary excavation support and moisture sensitivity of on-site soils.
9. Provide recommendations regarding the allowable bearing capacity and estimated settlements for small structures that may be constructed in Area 4.
10. Provide a recommended friction coefficient between soil and concrete.
11. Provide a range of moduli of subgrade reaction for concrete slabs.
12. Provide general opinions regarding dewatering and site drainage.
13. Provide general recommendations for support of the proposed overlook and boardwalk structures. We include pier mat foundations, pin piles and helical anchors.
14. Provide layer thickness recommendations for crushed surfacing material and asphalt concrete pavement (ACP) design sections, including subgrade preparation. Provide typical pavement sections for heavy and light traffic areas, based on our experience.
15. Provide estimated infiltration rates for selected soil samples in accordance with methods described in the 2015 Pierce County Stormwater Manual (Manual).

3.0 SURFACE CONDITIONS

Most of the proposed Area 4 improvements are located within the bottom of the Ohop Creek Valley, near the Nisqually River (Figure 2). The valley is oriented northeast to southwest and is bounded to the southwest by the Nisqually River. Steep to very steep valley walls are located on the northwest and southeast sides of the valley. Ohop Creek is located on the north side of the valley in Area 4. Ground surface elevations in the valley bottom vary from about 450 to 465 feet in the site area. This area is relatively flat with a slight downward slope to the southwest. This area is vegetated with a thick ground cover of brush and ferns. Fir and deciduous trees are present throughout the area. The site access road traverses across the valley bottom from southeast to northwest.

At the southwest valley wall, the site access road curves to the northeast and traverses the Ohop Valley wall from southwest to northeast. Site elevations along this road segment range from 460 feet in the southwest to about 600 feet in the northeast. This segment of the road is about 3,000 feet long. In places the northwest edge of the road is very near the top of a steep slope.

The remainder of the access road is located within the plateau area. This area has a gradual downward slope to the southwest-west. The proposed non-motorized boat trailer and bus parking lot (Figure 2) is located within the plateau area. A gradual swale exists in this area. The swale is vegetated in low grasses. We observed the presence of many boulders in this area. The swale is bounded to the northwest and southeast by areas thickly vegetated in brush.

3.1. Geologic Conditions

Geologic conditions at the site and nearby area were evaluated by reviewing the Washington State Department of Natural Resources “Geologic Map of the Centralia Quadrangle, Washington, 1987.” Materials mapped in the upland plateau area comprises Vashon Drift, Undifferentiated (map unit Qdv). This deposit is mapped over a broad area at and around the project site. These geologic materials are described as glacial outwash with silts, clays, lacustrine and some ice contact deposits.

Alluvium (map unity Qal) is mapped in the Ohop Creek Valley. This material is described as sand and gravel deposited by flowing water. Mashel Formation bedrock is mapped along the steep Ohop Creek valley walls. This material is described as Miocene-age sedimentary rocks, comprising mostly fine-grained fluvial and lacustrine deposits.

4.0 FIELD EXPLORATIONS AND LABORATORY TESTING

4.1. Field Explorations

Soil and groundwater conditions in Area 4 were explored by excavating five test pits on January 20, 2021. The test pits were completed by Kelly’s Excavating.

The approximate locations of the explorations completed for this project are presented on the Site Plan, Figure 2. Details of the field exploration program and logs of the explorations are presented in Appendix A, Field Explorations and Laboratory Testing.

4.2. Laboratory Testing

Soil samples obtained during our site exploration were taken to GeoEngineers’ laboratory for further evaluation. Selected samples were tested for the determination of moisture content, grain-size distribution (sieve analysis) and hydrometer testing. Descriptions of the laboratory testing and the test results are presented in Appendix A.

4.3. Subsurface Conditions

4.3.1. Plateau

In test pit TH-4B, we encountered gravel with variable amounts of silt and sand to a depth of 6 feet. Very hard silt, possible Mashel Formation bedrock, was encountered below the gravel to the full depth explored (8 feet). Approximately 4 inches of sod was encountered in this test pit.

4.3.2. Ohop Valley

In general, we encountered layers of loose sand with variable silt over relatively clean medium dense to dense gravel in all of the test pits. Cobbles and occasional boulders were encountered in the gravel deposits. We interpret the sand with silt material as comprising alluvium. The relatively clean gravel soil

was encountered at depths ranging from 1 to 9 feet in the test pits. This soil unit is likely a combination of glacial outwash and alluvium.

Approximately 5.5 feet of fill material was encountered in test pit TB-4A, which was advanced within a former bridge approach fill prism. The fill was in a dense to loose condition and comprised sand with some gravel.

4.3.3. Groundwater

Rapid groundwater seepage was observed in TH-4B below about 2.5 feet. Groundwater was not encountered in TB-4A. Rapid groundwater seepage was encountered in TB-4B, TB-4C and TH-4A at depths ranging from 9.25 to 11 feet.

We expect that future groundwater levels in the plateau area will vary with precipitation and depth to impermeable layers beneath the outwash material. Future groundwater levels in the Ohop Valley will depend on precipitation and surface water levels in Ohop Creek and the Nisqually River.

5.0 CONCLUSIONS AND RECOMMENDATIONS

5.1. Summary of Geotechnical Considerations

Based on our observations and the results of our subsurface exploration and testing program, it is our opinion that Area 4 is generally suitable for the proposed development. A summary of the primary geotechnical considerations for facilities planned in Area 4 is provided below. The summary is presented for introductory purposes only and should be used in conjunction with the detailed recommendations presented in this report.

- The near-surface soils in the upland area test pit (TH-4B) and in one of the Ohop Valley test pits (TH-4A) contain a moderate percentage of fines and are sensitive to small changes in moisture content. These soils are susceptible to disturbance from construction traffic when the moisture content is more than a few percent above the optimum moisture content for compaction. These soils will be difficult to work or compact when wet or if earthwork is performed in wet weather. The relatively clean sand and gravel soils encountered in other Ohop Valley test pits contain a low to moderate percentage of fines. These soils may be suited for earthwork under wet and dry conditions. Cobbles and boulders were encountered in our explorations and should be anticipated during grading activities and site excavations.
- The relatively clean gravel soils encountered in the test pits may be suited for use as structural fill during wet and dry weather conditions.
- We recommend all new fill placed below boardwalk, overlook, roadway, driveway and roadway areas be placed and compacted as structural fill. In areas where the structural fill is to be placed, the topsoil and root mass must be removed and the existing subgrade soils should be evaluated prior to fill placement to identify soft or unsuitable soils through either probing or proof-rolling with heavy, rubber-tired construction equipment.
- Based on the results of our subsurface explorations and laboratory testing programs only limited stormwater infiltration can be anticipated for the upland parking area due to shallow groundwater

conditions. Stormwater infiltration should be possible in the Ohop Valley areas based on the grain-size analyses as summarized in a subsequent section.

5.2. Site Preparation and Earthwork

5.2.1. General

Site development work will include removing existing trees and vegetation, stripping of forest duff/topsoil and root layer and stripping unsuitable material in the access road. The near-surface site soils are moisture sensitive due to moderate to high fines content. Grading these soils is more practical during the dry season (typically July through September). Moisture conditioning necessary to obtain proper compaction of these soils will likely not be practical during the cooler and wetter winter months and may still present challenges during the normally dry summer months. We recommend a contingency be included in the project budget and schedule for export of unsuitable wet on-site soil and import of select granular soil if earthwork will be performed during periods of wet weather.

The following sections provide our recommendations for earthwork, site development, and fill materials.

5.2.2. Stripping and Clearing

The existing trees, shrubs, topsoil, unsuitable soils and boulders should be stripped and removed from all proposed overlook, parking, driveway and roadway areas. Based on our explorations, the depth of stripping to remove unsuitable surface organic materials should generally vary between 6 and 12 inches. Greater stripping depths will be required to remove localized zones of loose or organic-rich soil and tree roots or if large boulders are encountered. The primary root systems for trees and shrubs should be completely removed. Required stripping depths should be evaluated based on observations during the stripping operation. Stripped organic material should be transported off site for disposal or processed and used as fill in landscaping areas. Excavations for boulder depressions should be backfilled with structural fill compacted to the densities indicated in Section 5.4 “Fill Placement and Compaction” of this report.

5.2.3. Subgrade Evaluation

After stripping and excavation to planned subgrade is complete, we recommend the exposed soil be proofrolled or probed and then compacted to a firm and unyielding condition. If dry weather conditions persist, we recommend that the subgrade be evaluated by proofrolling with a loaded dump truck or similar heavy rubber-tired construction equipment to identify soft, loose or unsuitable areas. Proofrolling must be conducted prior to placing fill. If the subgrade is prepared during or exposed to wet weather, we recommend that it be evaluated by probing with a steel probe rod.

The proofrolling/probing should be observed by a qualified geotechnical engineer, who will evaluate the suitability of the subgrade and identify any areas of yielding, which are indicative of soft or loose soil. If soft or otherwise unsuitable areas revealed during proofrolling cannot be compacted to a stable and uniformly firm condition, we recommend that: (1) the subgrade soils be scarified (e.g., with a ripper or a farmer’s disc), aerated and recompacted; or (2) the unsuitable soils be excavated to firm soil and replaced with structural fill, as recommended by the geotechnical engineer.

5.2.4. Excavation

Conventional earthmoving equipment in proper working order should be capable of making necessary excavations for utilities and footings. We recommend that footing and trench excavations be performed using a smooth-blade bucket to prevent excessive disturbance of the excavation base.

Boulders and large cobbles were observed in the trailer and bus parking area (TH-4B) and should be anticipated during grading and/or utility excavations. Accordingly, the contractor should be prepared to remove boulders, if encountered. Boulders may be removed from the site or buried in landscape areas. Voids caused by boulder removal must be backfilled with structural fill.

5.2.5. Excavation Support

Shallow excavations (4 feet or less) in medium dense to dense deposits should stand at near vertical inclinations, provided groundwater seepage is not present in the cut face. Excavations deeper than 4 feet must be shored or laid back at a stable slope if workers are required to enter.

Shoring for utility excavations must conform with the provisions of Title 296 Washington Administrative Code (WAC), Part N, "Excavation, Trenching and Shoring." Regardless of the soil type encountered in the excavation, shoring, trench boxes or sloped sidewalls will be required under Washington Industrial Safety and Health Act (WISHA). While this report describes certain approaches to excavation and dewatering, the contract documents should specify that the contractor is responsible for selecting excavation and dewatering methods, monitoring the excavations for safety and providing shoring, as required, to protect personnel and adjacent structures.

5.2.6. Weather Considerations

In places, the upper 1 to 5 feet of the native soils contain a sufficient percentage of fines (silt) to be moisture sensitive. When the moisture content of these soils is appreciably above the optimum moisture content, these soils become muddy and unstable, operation of equipment on these soils will be difficult, and it will be difficult to meet the required compaction criteria. Additionally, disturbance of these near-surface soils should be expected if earthwork is completed during periods of wet weather.

The wet weather season generally begins in early November and continues through April in Western Washington; however, periods of wet weather may occur during any month of the year. The optimum earthwork period for these types of soils is typically June through October. If wet weather earthwork is unavoidable, we recommend that:

- Structural fill placed during the wet season or during periods of wet weather consist of gravel borrow (Section 9-03.14(1) of the 2020 Washington State Department of Transportation (WSDOT) Standard Specifications) with the added restriction that no more than 5 percent (of the material passing the U.S. No. 200 sieve). The unweathered recessional outwash soils encountered below a depth of about 3 to 4 feet at the site will also be suitable as well as the cleaner soils encountered in the borrow pit area.
- The ground surface in and around the work areas be sloped so that surface water is directed away from the work areas. The ground surface should be graded such that areas of ponded water do not develop. Measures should be taken by the contractor to prevent surface water from collecting in excavations and trenches. Measures should be implemented to remove surface water from the work area.

5.2.7. Erosion and Sedimentation Control

The site will be susceptible to erosion during wet weather conditions, particularly if large segments of exposed subgrades are exposed to rainfall. Proposed improvements are also located near Ohop Creek and the Nisqually River.

Development, implementation and adherence to an Erosion and Sedimentation Control Plan should reduce the project impact on erosion-prone areas. The Plan should be designed in accordance with applicable county and/or state standards. The Plan should incorporate basic planning principles, including:

- Scheduling grading and construction to reduce soil exposure.
- Re-vegetating or mulching denuded areas.
- Directing runoff away from exposed soils.
- Reducing the length and steepness of slopes with exposed soils.
- Decreasing runoff velocities.
- Preparing drainage ways and outlets to handle concentrated or increased runoff.
- Confining sediment to the project site.
- Inspecting and maintaining control measures frequently.

Some sloughing erosion and raveling of exposed or disturbed soil on slopes should be expected, particularly if the work is completed during the wet season. We recommend that disturbed soil be restored promptly so that surface runoff does not become channeled.

Temporary erosion protection should be used and maintained in areas with exposed or disturbed soils to help reduce erosion and transport of sediment to adjacent areas and receiving waters. Permanent erosion protection should be provided by paving, structure construction or landscape planting.

Until the permanent erosion protection is established and the site is stabilized, site monitoring may be required by qualified personnel who will evaluate the effectiveness of the erosion control measures and recommend repairs and/or modifications as appropriate. Provision for modifications to the erosion control system based on monitoring observations should be included in the Erosion and Sedimentation Control Plan.

5.3. Fill Materials

The workability of material used as structural fill depends on the gradation and moisture content of the soil. As the amount of fines (material passing the U.S. No. 200 sieve) increases, soil becomes increasingly sensitive to small changes in moisture content and adequate compaction becomes more difficult, if not impossible to achieve. As discussed previously, we recommend that select granular fill or crushed rock be used as structural fill during the rainy season. The following paragraphs summarize the material requirements for fill and backfill.

5.3.1. On-site Soils

The near-surface silty sand soils may be considered for use as structural fill during periods of extended dry weather, provided they can be properly moisture conditioned and do not contain an unacceptable amount

of organic materials. The underlying clean sand alluvial and clean gravel outwash soils encountered in the Ohop Valley test pits can likely be used as structural fill during wet and dry weather conditions. On-site materials used as structural fill must be free of roots, organic matter and other deleterious materials and particles larger than 3 inches in diameter.

5.3.2. Borrow Pit Soils

The relatively clean sand and gravel soils may be considered for use as structural fill during periods of wet and dry weather. The siltier sand soils may be considered for use as structural fill during periods of extended dry weather, provided they can be properly moisture conditioned and do not contain an unacceptable amount of organic materials. The fill soils encountered in the borrow pit should not be considered for use as structural fill.

5.3.3. Select Granular Fill

Select granular fill (pit run) must consist of imported well-graded sand, sandy gravel, or crushed rock with a maximum particle size of 3 inches and less than 5 percent passing a U.S. No. 200 sieve. Organic matter, debris, or other deleterious material must not be present. Granular fill used during periods of prolonged dry weather may have up to 12 percent passing a U.S. No. 200 sieve.

5.3.4. Pipe Bedding

Trench backfill for the bedding and pipe zone must consist of well-graded granular material with a maximum particle size of $\frac{3}{4}$ inch and less than 5 percent passing the U.S. No. 200 sieve. The material must be free of roots, debris, organic matter, and other deleterious material.

5.3.5. Crushed Rock

Crushed rock fill must consist of clean, durable, crushed angular rock that has a maximum particle size of 4 inches, is well graded between coarse and fine sizes, and has less than 5 percent fines (material finer than a U.S. No. 200 sieve). A smaller maximum particle size will be required for some applications as discussed in other sections of this report. Gravel materials should be crushed to have at least two fractured faces. Organic matter, debris, or other deleterious material must not be present.

5.4. Fill Placement and Compaction

5.4.1. General

Fill soils should be compacted at a moisture content near optimum. The maximum allowable moisture content varies with the soil gradation and should be evaluated during construction. Fill and backfill material should be placed in uniform, horizontal lifts, and uniformly densified with vibratory compaction equipment. The maximum lift thickness will vary depending on the material and compaction equipment used but should generally not exceed 10 inches in loose thickness. We recommend that density testing of the placed structural fill be completed by a qualified geotechnical engineer to check that the structural fill compaction requirements presented in this report are achieved.

5.4.2. Area Fills and Bases

Fill placed to raise site grades and aggregate base materials under foundations, slabs, and parking/driveway areas should be placed on a prepared subgrade that consists of firm, inorganic native soils or compacted fill. Fill must be compacted to at least 95 percent of the maximum dry density (MDD) determined

by ASTM International (ASTM) Test Method D 1557 (modified Proctor). In pavement areas, the compaction criteria can be reduced to 92 percent below a depth of 2 feet from finished grade.

During wet weather or in areas that are particularly sensitive to subgrade disturbance, we recommend placing a woven geotextile between the subgrade and the first lift of fill. For this application, the first lift must comprise select granular fill. We recommend a 10-inch lift thickness and densification by static rolling for the initial lift.

5.4.3. Trench Backfill

Backfill in the bedding and pipe zone should be compacted to 90 percent of the MDD as determined by ASTM Test Method D 1557, or as recommended by the pipe manufacturer.

In nonstructural areas, trench backfill above the pipe zone should be compacted to at least 85 percent of the MDD as determined by ASTM Test Method D 1557. Suitable native soils or select granular soils should be acceptable in non-structural areas.

Within structural areas (beneath roadways and all site facilities), trench backfill placed above the pipe zone must be compacted to at least 92 percent of the MDD as determined by ASTM Test Method D 1557 at depths greater than 2 feet below the finished subgrade, and to 95 percent within 2 feet of finished subgrade. Trench backfill in structural areas should consist of select granular fill or crushed rock as described in the previous sections.

5.5. Temporary and Permanent Slopes

We recommend that permanent cut and fill slopes be inclined no steeper than 2H:1V (horizontal:vertical). Flatter cut slopes may be necessary in areas where persistent groundwater seepage or zones of soft or loose soils are encountered. Temporary cut slopes should be inclined no steeper than about 1½H:1V. Surface loads should be kept at a minimum distance of at least one-half the depth of the cut away from the top of temporary slopes.

As previously stated, temporary cut slopes and shoring must comply with the provisions of Title 296 WAC, Part N, "Excavation, Trenching and Shoring." The contractor performing the work must have the primary responsibility for protection of workmen and adjacent improvements, determining whether shoring is required, and for establishing the safe inclination for open-cut slopes.

To reduce the potential for erosion, newly constructed slopes should be planted or hydroseeded shortly after completion of grading. Some sloughing and raveling of the slopes should be expected until the vegetation is established. This may require localized repairs and reseeded. Temporary covering, such as heavy plastic sheeting, jute fabric, loose straw, or excelsior matting should be used to protect unvegetated slopes during periods of rainfall.

5.6. Foundation Support

5.6.1. Shallow Foundations

We understand that a few small structures may be constructed as a part of Area 4 development. These proposed buildings can be supported on continuous wall or isolated column footings established on undisturbed medium dense native soils following compaction, or on a minimum 2-foot thickness of

structural fill. Isolated column and continuous wall footings should have minimum widths of 24 and 18 inches, respectively.

The exterior footings should be established at least 24 inches below the lowest adjacent grade for frost protection. Interior footings can be founded a minimum of 12 inches below the top of the floor slab.

5.6.2. Bearing Capacity

We recommend that footings founded as recommended be proportioned using an allowable bearing pressure of 3,000 pounds per square foot (psf). This assumes that the footings bear on the recompacted native outwash material or on a minimum 2-foot thickness of structural fill. This bearing pressure applies to the total of dead and long-term live loads and may be increased by one-third when considering earthquake or wind loads. This is a net bearing pressure. The weight of the footing and overlying backfill can be ignored in calculating footing sizes.

5.6.3. Footing Subgrade Preparation

Footing excavations should be performed using a smooth-edged bucket to limit bearing surface disturbance. Loose or disturbed materials present at the base of footing excavations should be removed or compacted. Foundation bearing surfaces should not be exposed to standing water. If water infiltrates and pools in the excavation, it must be removed and the bearing surface reevaluated before placing structural fill or reinforcing steel.

We recommend that an experienced geotechnical engineer observe all foundation excavations before placing reinforcing steel in order to confirm that adequate bearing surfaces have been achieved and that the soil conditions are as anticipated. Unsuitable foundation subgrade soils must be removed and replaced with structural fill as recommended by the geotechnical engineer. It may be prudent to place a thin mud mat of lean concrete to protect the bearing surface if footing excavations are to remain open in wet weather.

5.6.4. Foundation Settlement

We estimate that settlements of footings designed and constructed as recommended will be less than $\frac{3}{4}$ inch, for the anticipated loading conditions. Differential settlements between comparably loaded isolated column footings or along 50 feet of continuous footing should be less than $\frac{1}{2}$ inch. Settlement is expected to occur rapidly as loads are applied.

5.6.5. Lateral Resistance

The ability of the soil to resist lateral loads is a function of frictional resistance, which can develop on the base of footings and slabs and the passive resistance, which can develop on the face of below-grade elements of the structure as these elements tend to move into the soil. For footings and floor slabs founded in accordance with the recommendations presented above, the allowable frictional resistance may be computed using a coefficient of friction of 0.35 applied to vertical dead-load forces. The allowable passive resistance on the face of footings, grade beams or other embedded foundation elements may be computed using an equivalent fluid density of 250 pounds per cubic foot (pcf) for undisturbed on-site soils or structural fill extending out from the face of the foundation element a distance at least equal to two and one-half times the depth of the element.

The passive earth pressure and friction components may be combined provided that the passive component does not exceed two-thirds of the total. The passive earth pressure value is based on the assumptions that the adjacent grade is level and that groundwater remains below the base of the footing throughout the year. The top foot of soil should be neglected when calculating passive lateral earth pressures unless the foundation area is covered with pavement or is inside a building.

The lateral resistance values include a safety factor of approximately 1.5.

5.6.6. Building Pads and Floor Slabs

A modulus of subgrade reaction of 100 pounds per cubic inch (pci) can be used for designing building floor slabs provided that the subgrade consists of structural fill that has been prepared in accordance with Section 5.4 "Fill Placement and Compaction." We anticipate relatively light slab/floor loading for the proposed structures (less than about 150 pounds per square foot). Settlements for the floor slabs designed and constructed as recommended are estimated to be less than $\frac{3}{4}$ inch. We estimate that differential settlement of the floor slabs, will be $\frac{1}{2}$ inch or less over a span of 50 feet providing that the fill below the slab is compacted uniformly as specified. The subgrade soils are non-expansive, so heave is not anticipated beneath the floor slab.

We recommend that on-grade slabs be underlain by a minimum 4-inch-thick capillary break layer to reduce the potential for moisture migration into the slab. The capillary break material should consist of a well-graded sand and gravel or crushed rock with negligible fines content. The material should be placed as recommended in Section 5.4 "Fill Placement and Compaction."

A vapor retarder should be used as necessary to control moisture penetration through the slab if areas of floor coverings, adhesives or tiles are planned.

5.7. Overlooks and Boardwalks

5.7.1. General

We understand that up to three overlooks are being considered for the Ohop Valley site. Two overlooks are being considered for the area southeast of Ohop Creek (TB-4A and TB-4B) and one is being considered for an area northeast of the Nisqually River (TB-4C). We understand an elevated boardwalk is also being considered for these areas. The extent, layout and proposed design of these features was not available at time of this report.

Based on conversations with you we understand that the overlooks could be supported on pier mat foundations, pin piles or helical anchors. The boardwalk could be supported on pin piles or helical anchors. Design parameters contained in the following sections are general in nature and should be reviewed/revised once the configuration of the proposed features has been finalized.

5.7.2. Pier Mat Foundations

Subgrade soils in pier mat foundation areas should be compacted to a firm and unyielding condition. Any soft, loose or otherwise unsuitable material exposed in these areas should be recompacted, if practical, or the material should be removed and replaced with controlled density fill (CDF) or concrete if the mat foundation is over poured. We recommend that a representative of our firm observe excavations, exposed subgrade soils and fill placement activities.

We recommend a minimum embedment depth of 36 inches for the mat foundations. We recommend that a modulus of subgrade reaction of 150 pounds per cubic inch (pci) be used for mat foundations bearing on dense native material or on controlled density fill extending down to these soils.

Lateral loads on foundation elements may be resisted by passive resistance on the sides of footings and other below-grade structural elements and by friction on the base of footings. Passive resistance may be estimated using an equivalent fluid density of 300 pcf, assuming that the footings and below-grade elements are backfilled with structural fill placed and compacted as recommended for a minimum distance at least equal to two and one-half times the depth of the element. Frictional resistance may be estimated using 0.35 for the coefficient of base friction. The above values incorporate a factor of safety of about 1.5.

5.8. Pin Piles

Pin piles generally consist of driving galvanized pipe piles into the underlying dense gravel soils using limited access equipment. Pin piles may not be feasible where surficial dense gravel layers are present. If this foundation alternative is selected additional field explorations and a pile test section is recommended to evaluate drivability. The smallest size of pile, 2-inch-diameter, can generally be installed using a pneumatic jackhammer. Larger 3- or 4-inch-diameter steel pipe piles can be installed using small, tracked equipment with an 850 to 1,100-pound hammer. We recommend pin piles be driven until achieving a penetration rate consistent with the criteria in Table 1.

TABLE 1. PIPE PILE REFUSAL CRITERIA AND RECOMMENDED CAPACITY

Hammer Size	Pile Diameter/Recommended Allowable Capacity (kips)			
	2-inch/4 kips	3-inch/12 kips	4-inch/20 kips	6-inch/30 kips
90 lbs	60 sec/inch	---	---	---
850 lbs	---	10 sec/inch	16 sec/inch	---
1,100 lbs	---	6 sec/inch	10 sec/inch	20 sec/inch

Notes:

lbs = pounds

sec/inch = seconds per inch

The above allowable axial capacities may be revised if on-site load tests confirm higher capacities are possible, and the structural engineer approves the selected pile type/size for the proposed loading. We recommend an allowable uplift capacity of 1 kip for 3- or 4-inch-diameter piles, assuming that the pile is one continuous section of pipe or that the joints are welded, and the pile length is a minimum of 8 feet. This allowable uplift capacity includes a factor of safety of at least 2. We estimate that static pile settlement will be less than 1/2 inch for properly installed pipe piles. Differential settlement along a 20-foot section of pile supported grade beam should be less than 1/4 inch. Lateral resistance is not typically developed in pin piles. We recommend that lateral loads be resisted by use of battered piles.

We recommend that a representative from our firm be on site during driving to verify that refusal criteria is achieved. A load test should be completed for each proposed pile type and selected hammer, to assess the ability to meet the driving criteria recommended above. Load testing is not required for 2-inch-diameter piles. The test piles should be loaded to at least 200 percent of the allowable design load. Pin pile load tests are typically accomplished by jacking against a large excavator or other piece of construction equipment. The excavator is centered over the top of the pile and a hydraulic jack equipped with a

hand-operated hydraulic pump and a pressure gauge is placed between the excavator and pile. The load is applied in increments of about 3 to 4 kips and downward deflection measurements are recorded at each load. The pile load tests should be observed by a geotechnical engineer from our firm. The load vs. deflection is plotted to determine the pile capacity and factor of safety.

5.9. Helical Piers/Piles

Helical piers typically include a lead section with one or multiple helical plates welded on a steel shaft, steel extension sections, and foundation repair brackets (when used for underpinning). Smaller piers can be installed with portable rotary tools, a digger motor on a utility truck, caisson drills, or a backhoe or other equipment with a torque motor attached. Larger piers require specialized torque motors and equipment. Similar to pin piles, dense gravel layers will impede advancement. Additional explorations and testing is recommended if this foundation alternative is selected. Torque is typically monitored during anchor installation to verify capacities and for production control. Specific refusal criteria can be developed during final design depending on the required capacity and the contractor's equipment. However, as a minimum, the piers will need to extend into the gravel outwash deposits encountered in our test pits. The piers should also be protected from corrosion. Typical design capacities of helical piers used for foundation support are in the range of 10 to 25 tons each (depending on the size and number of helical plates). Because the shafts are relatively small, lateral resistance is typically obtained by battered piers.

5.10. Parking, Driveway and Access Road Recommendations

5.10.1. General

We understand that lightly loaded vehicles will generally access the roadway and various sites in Area 4. However, we anticipate that heavier service vehicles will likely occasionally utilize the roadway. The native subgrades for the roadway, driveway and parking areas should be prepared and evaluated in accordance with Section 5.2 "Site Preparation and Earthwork" of this report.

As previously noted, a portion of the existing access road is close to the top of a very steep slope, that likely meets the technical criteria for a landslide hazard area. We recommend that the project team consider moving the roadway to the southeast to achieve some measure of setback from the top of the steep slope area. A specific setback recommendation would require additional geotechnical evaluation.

5.10.2. Asphaltic Pavement

Based on our experience with similar projects, we provide typical asphalt concrete (AC) pavement sections below. These pavement sections are typical for commercial facilities but may not be adequate for heavy construction traffic loads such as those imposed by concrete transit mixers, dump trucks or cranes or for unusual design traffic conditions. Additional pavement thickness may be necessary to prevent pavement damage during construction or if anticipated truck traffic for this facility is higher than typical. We can provide a specific design if detailed truck traffic loading information is provided. The recommended sections assume that final improvements surrounding the pavement will be designed and constructed such that stormwater or excess irrigation water from landscape areas does not accumulate below the pavement section or pond on pavement surfaces.

Pavement subgrade must be prepared as previously described. Crushed surfacing base course and subbase must be moisture conditioned to near optimum moisture content and compacted to at least 95 percent of MDD (ASTM D 1577).

Crushed surfacing base course must conform to applicable sections of 4-04 and 9-03.9(3) of the WSDOT Standard Specifications. Hot mix asphalt must conform to applicable sections of 5-04, 9-02 and 9-03 of the WSDOT Standard Specifications. PCC must conform to applicable sections of 5-05, 9-01 and 9-03 of the WSDOT Standard Specifications.

5.10.2.1. Standard-Duty ACP – Automobile Driveways and Parking Areas

- 2 inches of hot mix asphalt, class ½ inch, PG 58-22
- 4 inches of crushed surfacing base course
- 6 inches of subbase consisting of select granular fill to provide uniform grading and pavement support, to maintain drainage, and to provide separation from fine-grained subgrade soil
- Native subgrade or structural fill prepared in accordance with Section 5.2 “Site Preparation and Earthwork”

5.10.2.2. Heavy-Duty ACP – Areas Subject to Truck Traffic and the Proposed Access Road

- 3 inches of hot mix asphalt, class ½ inch, PG 58-22
- 6 inches of crushed surfacing base course
- 6 inches of subbase consisting of select granular fill to provide a uniform grading surface and pavement support, to maintain drainage, and to provide separation from fine-grained subgrade soil
- Native subgrade or structural fill prepared accordance with Section 5.2 “Site Preparation and Earthwork”

5.11. Preliminary Infiltration Evaluation

We evaluated the preliminary infiltration potential of select samples of soils encountered in our test pits by estimating design infiltration rates using criteria provided in the Method 2, Appendix III-A of the 2015 Manual.

TABLE 2. ESTIMATED PRELIMINARY SOIL INFILTRATION RATES¹

Test Pit No.	Soil Sample No.	Soil Sample Depth (feet)	Percent Fines ²	Percent Gravel and Coarse Sand ³	Estimated Preliminary Design Infiltration Rate (inches/hour) ⁴
TH-4B	1	3	8	80	2
TH-4A	2	6	2	20	2
TB-4A	2	6	8	50	0.5
TB-4C	1	3.5	1	78	2

Notes:

- ¹ For selected soil samples.
- ² Defined as particles passing the No. 200 sieve.
- ³ Defined as particles retained on the No. 10 sieve.
- ⁴ Derived by Method 2 within Appendix III-A of the 2015 Pierce County Stormwater Manual.

Based on our evaluation, the test pit results and our experience, it is our opinion that stormwater infiltration is possible at the site, particularly in the clean gravel alluvium/outwash in the Ohop Valley. The lab test data indicate infiltration is possible in the

upland area (TH-4B). However, relatively shallow groundwater in this area will limit the amount of infiltration possible. In this area we recommend that the infiltration facilities be designed to infiltration stormwater over a relatively wide area.

6.0 LIMITATIONS

We have prepared this report for use by Robert W. Droll, Landscape Architects. This report may be made available to regulatory agencies. Our analysis, interpretations and conclusions should not be construed as a warranty of subsurface conditions beneath the site. We have relied on information prepared and supplied by others in developing our recommendations. GeoEngineers makes no representations as to the accuracy or reliability of these data.

Within the limitations of scope, schedule and budget, our services have been executed in accordance with generally accepted practices in the field of geotechnical engineering in this area at the time this report was prepared. The conclusions, recommendations, and opinions presented in this report are based on our professional knowledge, judgment and experience. No warranty or other conditions, express or implied, should be understood.

Please refer to Appendix B titled “Report Limitations and Guidelines for Use” for additional information pertaining to use of this report.

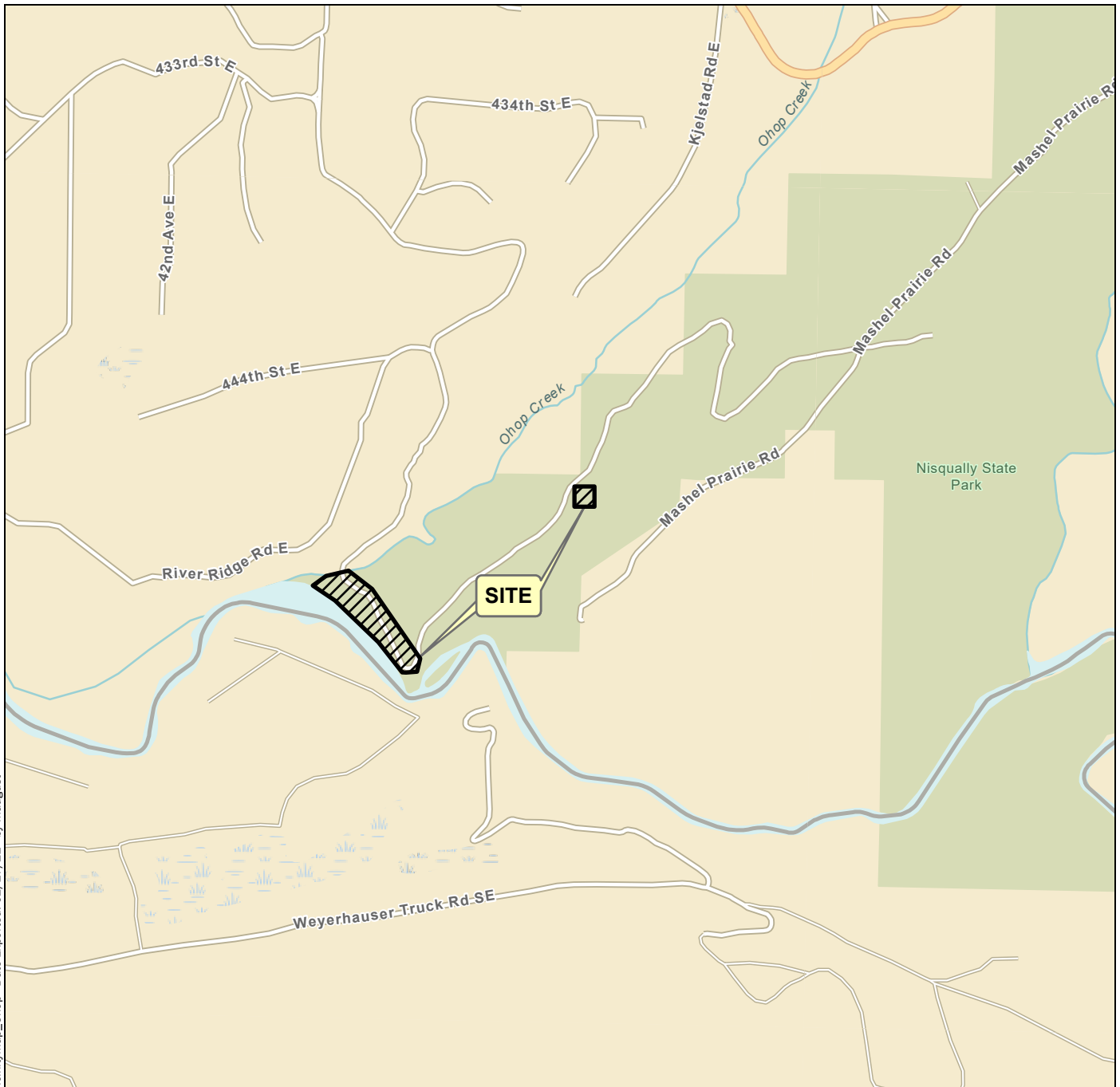

P:\2935067\GIS\2935067_Project\2935067_F01_VicinityMap_Ohop Date Exported: 02/17/21 by maugust

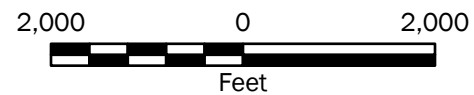
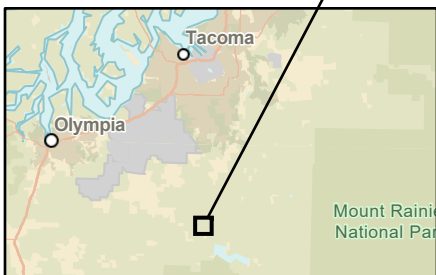

Vicinity Map

Ohop Area - Nisqually State Park
Pierce County, Washington



Figure 1

Notes:

1. The locations of all features shown are approximate.
2. This drawing is for information purposes. It is intended to assist in showing features discussed in an attached document. GeoEngineers, Inc. cannot guarantee the accuracy and content of electronic files. The master file is stored by GeoEngineers, Inc. and will serve as the official record of this communication.

Data Source: ESRI

Projection: NAD 1983 StatePlane Washington North FIPS 4601 Feet

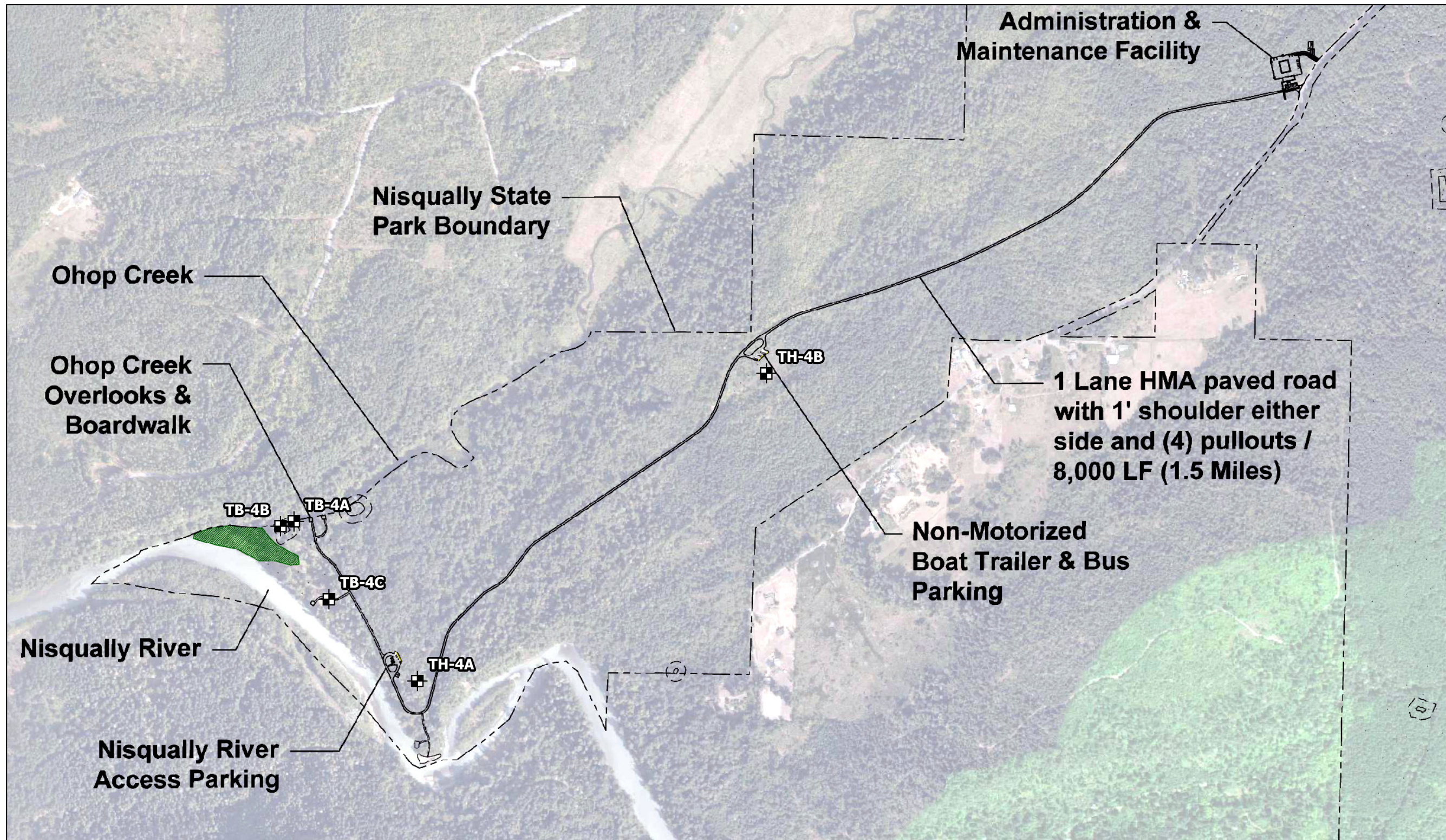

P:\2935067\GIS\2935067_Project\2935067_F02_SitePlan_Ohop Date Exported: 02/17/21 by maugust

Data Source:

 Approximate Test Pit Location

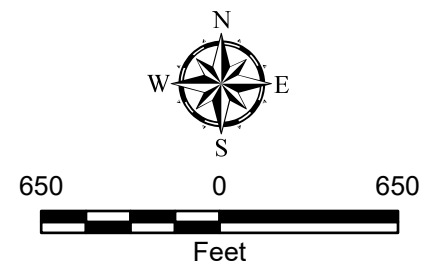

Site Plan	
Ohop Area - Nisqually State Park Pierce County, Washington	
	Figure 2

APPENDIX A
Field Explorations and Laboratory Testing

APPENDIX A FIELD EXPLORATIONS AND LABORATORY TESTING

Field Explorations

Soil and groundwater conditions were explored at the site by observing and collecting soil samples in five test pit explorations completed by Kelly's Excavating on January 22, 2021. Explorations were completed to depths ranging from 8 to 14 feet each. Exploration locations should be considered approximate and are shown on the Site Plan, Figure 2.

Test pits were continuously monitored by our representative who maintained a log of subsurface conditions, visually classified the soils encountered, and obtained representative soil samples. Soils encountered were visually classified in general accordance with the classification system described in Figure A-1. Test pit logs are presented in Figures A-2 through A-6. The logs are based on our interpretation of the field and laboratory data and indicate the various types of soils encountered. They also indicate the depths at which the soil characteristics change, although the change might actually be gradual. The ground surface elevations shown on the logs are based on LiDAR data reviewed by GeoEngineers.

Laboratory Testing

Soil samples obtained from the explorations were brought to our laboratory to confirm field classifications. Selected samples were tested to determine their moisture content and grain-size distribution in general accordance with applicable ASTM International (ASTM) standards.

The moisture content of selected samples was determined in general accordance with ASTM Test Method D 2216. The test results are presented in the respective test pit logs in Appendix A. Grain-size distribution (sieve analyses) and hydrometer testing were conducted in general accordance with ASTM Test Method D 422. The results of the grain-size analyses are presented in Figures A-7 and A-8.

SOIL CLASSIFICATION CHART

MAJOR DIVISIONS			SYMBOLS		TYPICAL DESCRIPTIONS
			GRAPH	LETTER	
COARSE GRAINED SOILS	GRAVEL AND GRAVELLY SOILS	CLEAN GRAVELS <small>(LITTLE OR NO FINES)</small>		GW	WELL-GRADED GRAVELS, GRAVEL - SAND MIXTURES
		GRAVELS WITH FINES <small>(APPRECIABLE AMOUNT OF FINES)</small>		GP	POORLY-GRADED GRAVELS, GRAVEL - SAND MIXTURES
		GRAVELS WITH FINES <small>(APPRECIABLE AMOUNT OF FINES)</small>		GM	SILTY GRAVELS, GRAVEL - SAND - SILT MIXTURES
	SAND AND SANDY SOILS	CLEAN SANDS <small>(LITTLE OR NO FINES)</small>		SW	WELL-GRADED SANDS, GRAVELLY SANDS
		SANDS WITH FINES <small>(APPRECIABLE AMOUNT OF FINES)</small>		SP	POORLY-GRADED SANDS, GRAVELLY SAND
		SANDS WITH FINES <small>(APPRECIABLE AMOUNT OF FINES)</small>		SM	SILTY SANDS, SAND - SILT MIXTURES
FINE GRAINED SOILS	SILTS AND CLAYS	LIQUID LIMIT LESS THAN 50		ML	INORGANIC SILTS, ROCK FLOUR, CLAYEY SILTS WITH SLIGHT PLASTICITY
		LIQUID LIMIT LESS THAN 50		CL	INORGANIC CLAYS OF LOW TO MEDIUM PLASTICITY, GRAVELLY CLAYS, SANDY CLAYS, SILTY CLAYS, LEAN CLAYS
		LIQUID LIMIT LESS THAN 50		OL	ORGANIC SILTS AND ORGANIC SILTY CLAYS OF LOW PLASTICITY
	SILTS AND CLAYS	LIQUID LIMIT GREATER THAN 50		MH	INORGANIC SILTS, MICACEOUS OR DIATOMACEOUS SILTY SOILS
		LIQUID LIMIT GREATER THAN 50		CH	INORGANIC CLAYS OF HIGH PLASTICITY
		LIQUID LIMIT GREATER THAN 50		OH	ORGANIC CLAYS AND SILTS OF MEDIUM TO HIGH PLASTICITY
HIGHLY ORGANIC SOILS			PT	PEAT, HUMUS, SWAMP SOILS WITH HIGH ORGANIC CONTENTS	

NOTE: Multiple symbols are used to indicate borderline or dual soil classifications

Sampler Symbol Descriptions

	2.4-inch I.D. split barrel
	Standard Penetration Test (SPT)
	Shelby tube
	Piston
	Direct-Push
	Bulk or grab
	Continuous Coring

Blowcount is recorded for driven samplers as the number of blows required to advance sampler 12 inches (or distance noted). See exploration log for hammer weight and drop.

"P" indicates sampler pushed using the weight of the drill rig.

"WOH" indicates sampler pushed using the weight of the hammer.

NOTE: The reader must refer to the discussion in the report text and the logs of explorations for a proper understanding of subsurface conditions. Descriptions on the logs apply only at the specific exploration locations and at the time the explorations were made; they are not warranted to be representative of subsurface conditions at other locations or times.

ADDITIONAL MATERIAL SYMBOLS

SYMBOLS		TYPICAL DESCRIPTIONS
GRAPH	LETTER	
	AC	Asphalt Concrete
	CC	Cement Concrete
	CR	Crushed Rock/Quarry Spalls
	SOD	Sod/Forest Duff
	TS	Topsoil

Groundwater Contact



Measured groundwater level in exploration, well, or piezometer



Measured free product in well or piezometer

Graphic Log Contact

Distinct contact between soil strata

Approximate contact between soil strata

Material Description Contact

Contact between geologic units

Contact between soil of the same geologic unit

Laboratory / Field Tests

%F	Percent fines
%G	Percent gravel
AL	Atterberg limits
CA	Chemical analysis
CP	Laboratory compaction test
CS	Consolidation test
DD	Dry density
DS	Direct shear
HA	Hydrometer analysis
MC	Moisture content
MD	Moisture content and dry density
Mohs	Mohs hardness scale
OC	Organic content
PM	Permeability or hydraulic conductivity
PI	Plasticity index
PL	Point load test
PP	Pocket penetrometer
SA	Sieve analysis
TX	Triaxial compression
UC	Unconfined compression
VS	Vane shear

Sheen Classification

NS	No Visible Sheen
SS	Slight Sheen
MS	Moderate Sheen
HS	Heavy Sheen

Key to Exploration Logs



Figure A-1

Date Excavated	1/20/2021	Total Depth (ft)	9.5	Logged By	CJL	Excavator	Kelly's Excavating	See "Remarks" section for groundwater observed See "Remarks" section for caving observed
				Checked By	SWH	Equipment	Komatsu PC120	
Surface Elevation (ft) Vertical Datum	463 NAVD88		Latitude Longitude	46° 50' 45.5178" -122° 22' 04.2226"		Coordinate System Horizontal Datum	WA State Plane South NAD83 (feet)	

Elevation (feet)	Depth (feet)	SAMPLE		Graphic Log	Group Classification	MATERIAL DESCRIPTION	Moisture Content (%)	Fines Content (%)	REMARKS
		Testing Sample	Sample Name Testing						
					DUFF	Approximately 6 inches of forest duff			
462	1				SM	Brown-gray silty fine sand with occasional 1/4- to 1/2-inch roots (loose, moist) (alluvium)			
461	2				SP-SM	Brown-gray fine sand with silt (loose, moist) (alluvium)			
460	3		SA		SM	Brown-gray silty fine sand with trace 1/2-inch roots (loose, moist) (alluvium)	29	40	Heavy caving observed from 3 to 6 feet
459	4				SP-SM	Brown-gray fine to coarse sand with silt and gravel (loose, moist) (alluvium)			
458	5				SP	Gray fine to medium sand with gravel and trace silt (medium dense, moist) (outwash/alluvium)			
457	6		SA		SM	Brown-gray silty fine sand with trace 1/2-inch roots (loose, moist) (alluvium)	6	2	
456	7				SM	Brown-gray silty fine sand with trace 1/2-inch roots (loose, moist) (alluvium)			
455	8				SM	Brown-gray silty fine sand with trace 1/2-inch roots (loose, moist) (alluvium)			
454	9		3		GP	Gray fine to coarse gravel with sand, cobbles and trace silt (dense, wet) (outwash/alluvium)			Rapid groundwater seepage observed at 9 1/2 feet

Notes: See Figure A-1 for explanation of symbols.
The depths on the test pit logs are based on an average of measurements across the test pit and should be considered accurate to 1/2 foot.
Coordinates Data Source: Horizontal approximated based on . Vertical approximated based on .

Log of Test Pit TH-4A



Project: Area 4 Proposed Nisqually Access Area, Nisqually State Park
Project Location: Pierce County, Washington
Project Number: 2935-067-00

Figure A-2
Sheet 1 of 1

Date: 3/1/21 Path: P:\2935067\GINT\293506700.GPJ DBLibrary\Library\GEOENGINEERS_DF_STD_US_JUNE_2017.GLB\GEBB_TESTPIT_IP_GEODEC.XIF

Date Excavated	1/20/2021	Total Depth (ft)	8	Logged By	CJL	Excavator	Kelly's Excavating	See "Remarks" section for groundwater observed
		Checked By	SWH	Equipment	Komatsu PC120			See "Remarks" section for caving observed
Surface Elevation (ft) Vertical Datum	607 NAVD88		Latitude Longitude	46° 50' 56.784" -122° 21' 20.3353"		Coordinate System Horizontal Datum	WA State Plane South NAD83 (feet)	

Elevation (feet)	Depth (feet)	SAMPLE		Graphic Log	Group Classification	MATERIAL DESCRIPTION	Moisture Content (%)	Fines Content (%)	REMARKS
		Testing Sample	Sample Name Testing						
606	1				SOD	Approximately 4 inches of sod			Moderate caving observed from 1 to 3 feet
605	2				GM	Dark brown silty fine to coarse gravel with sand, cobbles and boulders (dense, moist) (glacial drift)			
604	3				GP-GM	Brown fine to coarse gravel with silt, sand, cobbles and boulders (dense, moist) (glacial drift)			Rapid perched groundwater seepage observed at 2 3/4 feet
603	4				GP	Grades to wet Brown fine to coarse gravel with sand, cobbles, boulders and trace silt (dense, wet) (glacial drift)	9	8	
602	5				ML	Gray with iron oxide staining silt with fine sand and trace gravel (very hard, moist) (Mashel formation)			
601	6								
600	7		2						
599	8								

Notes: See Figure A-1 for explanation of symbols.
The depths on the test pit logs are based on an average of measurements across the test pit and should be considered accurate to 1/2 foot.
Coordinates Data Source: Horizontal approximated based on . Vertical approximated based on .

Log of Test Pit TH-4B



Project: Area 4 Proposed Nisqually Access Area, Nisqually State Park
Project Location: Pierce County, Washington
Project Number: 2935-067-00

Figure A-3
Sheet 1 of 1

Date: 3/1/21 Path: P:\2935067\GINT\293506700.GPJ DBLibrary\Library\GEOENGINEERS_DF_STD_US_JUNE_2017.GLB\GEBB_TESTPIT_1P_GEODEC_3\F

Date Excavated	1/20/2021	Total Depth (ft)	14	Logged By	CJL	Excavator	Kelly's Excavating	Groundwater not observed
				Checked By	SWH	Equipment	Komatsu PC120	See "Remarks" section for caving observed
Surface Elevation (ft) Vertical Datum	459 NAVD88		Latitude Longitude	46° 50' 36.8129" -122° 21' 55.3169"		Coordinate System Horizontal Datum	WA State Plane South NAD83 (feet)	

Elevation (feet)	Depth (feet)	SAMPLE		Graphic Log	Group Classification	MATERIAL DESCRIPTION	Moisture Content (%)	Fines Content (%)	REMARKS
		Testing Sample	Sample Name Testing						
458	1				DUF	Approximately 6 inches of forest duff			
					GP	Brown-gray fine to coarse gravel with sand, cobbles and trace silt (dense, moist) (fill)			
457	2				SP	Brown-gray fine sand with trace silt and occasional gravel (loose, moist) (fill?)			
456	3	1				Grades to medium dense with occasional cobbles			
455	4								
454	5								
453	6	2			GP-GM	Brown-gray fine to coarse gravel with sand, silt, cobbles, occasional boulders (dense, moist) (outwash/alluvium)			Increased gravel
452	7								
451	8								
450	9								
449	10								
448	11				GP-GM	Brown-gray fine gravel with sand, silt, gravel and occasional cobbles (dense, moist) (outwash/alluvium)			
447	12	3				Grades to with fine roots at 12 to 12½ feet			Minor caving observed from 12 to 13 feet
446	13								
445	14				GP	Brown-gray fine to coarse gravel with sand, cobbles and trace silt (dense, moist) (outwash/alluvium)			

Notes: See Figure A-1 for explanation of symbols.
The depths on the test pit logs are based on an average of measurements across the test pit and should be considered accurate to ½ foot.
Coordinates Data Source: Horizontal approximated based on . Vertical approximated based on .

Log of Test Pit TB-4A



Project: Area 4 Proposed Nisqually Access Area, Nisqually State Park
Project Location: Pierce County, Washington
Project Number: 2935-067-00

Figure A-4
Sheet 1 of 1

Date: 3/1/21 Path: P:\2935067\GINT\293506700.GPJ\DL\Library\Library\GEOENGINEERS_DF_STD_US_JUNE_2017.GLB\GERB_TESTPIT_IP_GEODEC_%F

Date Excavated	1/20/2021	Total Depth (ft)	11.5	Logged By	CJL	Excavator	Kelly's Excavating	See "Remarks" section for groundwater observed	
				Checked By	SWH	Equipment	Komatsu PC120	See "Remarks" section for caving observed	
Surface Elevation (ft) Vertical Datum	469 NAVD88		Latitude Longitude	46° 50' 40.6862" -122° 22' 03.7204"		Coordinate System Horizontal Datum	WA State Plane South NAD83 (feet)		

Elevation (feet)	Depth (feet)	SAMPLE		Graphic Log	Group Classification	MATERIAL DESCRIPTION	Moisture Content (%)	Fines Content (%)	REMARKS
		Testing Sample	Sample Name Testing						
					DUFF	Approximately 8 inches of forest duff			Moderate caving observed from 0 to 5 feet
468	1				SP	Brown-gray fine to medium sand with occasional 1/4- to 1-inch roots and trace silt (loose, moist) (alluvium)			
467	2		1						
466	3					Grades to medium dense with occasional gravel			Occasional approximate 3- to 6-inch lenses of fine sand
465	4								
464	5					Grades to gray with trace gravel			
463	6		2 MC				5		
462	7								Severe caving observed from 7 to 11½ feet
461	8								
460	9				GP	Brown-gray fine to coarse gravel with sand, cobbles, occasional boulders and trace silt (dense, moist) (outwash/alluvium)			
459	10		3			Grades to wet			
458	11								Rapid groundwater seepage observed at 11 feet

Notes: See Figure A-1 for explanation of symbols.
The depths on the test pit logs are based on an average of measurements across the test pit and should be considered accurate to ½ foot.
Coordinates Data Source: Horizontal approximated based on . Vertical approximated based on .

Log of Test Pit TB-4B



Project: Area 4 Proposed Nisqually Access Area, Nisqually State Park
Project Location: Pierce County, Washington
Project Number: 2935-067-00

Figure A-5
Sheet 1 of 1

Date: 3/1/21 Path: F:\2935067\GINT\293506700.GPJ\DBLibrary\Library\GEOENGINEERS_DF_STD_US_JUNE_2017\GLB\GERB_TESTPIT_1P_GEODEC_5\F

Date Excavated	1/20/2021	Total Depth (ft)	9.5	Logged By	CJL	Excavator	Kelly's Excavating	See "Remarks" section for groundwater observed	
				Checked By	SWH	Equipment	Komatsu PC120	See "Remarks" section for caving observed	
Surface Elevation (ft)	459		Latitude	46° 50' 45.6756"		Coordinate System	WA State Plane South		
Vertical Datum	NAVD88		Longitude	-122° 22' 06.5208"		Horizontal Datum	NAD83 (feet)		

Elevation (feet)	Depth (feet)	SAMPLE		Graphic Log	Group Classification	MATERIAL DESCRIPTION	Moisture Content (%)	Fines Content (%)	REMARKS
		Testing Sample	Sample Name Testing						
458	1				SOD	Approximately 3 inches of sod			Old campfire
					SP-SM	Brown fine to medium sand with silt and deleterious debris (charcoal, glass and plastic) (loose, moist) (fill)			
457	2				GP	Brown-gray fine to coarse gravel with sand, cobbles, occasional boulders, trace silt and occasional 1/4- to 1-inch roots (medium dense, moist) (outwash/alluvium)			Moderate caving observed from 3 to 6 feet
456	3								
455	4		g1-4				3	1	
454	5								
453	6								
452	7								Severe caving observed from 7 to 9 1/2 feet
451	8								
450	9		g1-2			Grades to wet	6	1	Rapid groundwater observed at 9 1/4 feet

Notes: See Figure A-1 for explanation of symbols.
The depths on the test pit logs are based on an average of measurements across the test pit and should be considered accurate to 1/2 foot.
Coordinates Data Source: Horizontal approximated based on . Vertical approximated based on .

Log of Test Pit TB-4C



Project: Area 4 Proposed Nisqually Access Area, Nisqually State Park
Project Location: Pierce County, Washington
Project Number: 2935-067-00

Figure A-6
Sheet 1 of 1

Date: 3/1/21 Path: P:\2935067\GINT\293506700.GPJ DBLibrary\Library\GEOENGINEERS_DF_STD_US_JUNE_2017.GLB\GEBB_TESTPIT_IP_GEODEC_3\F

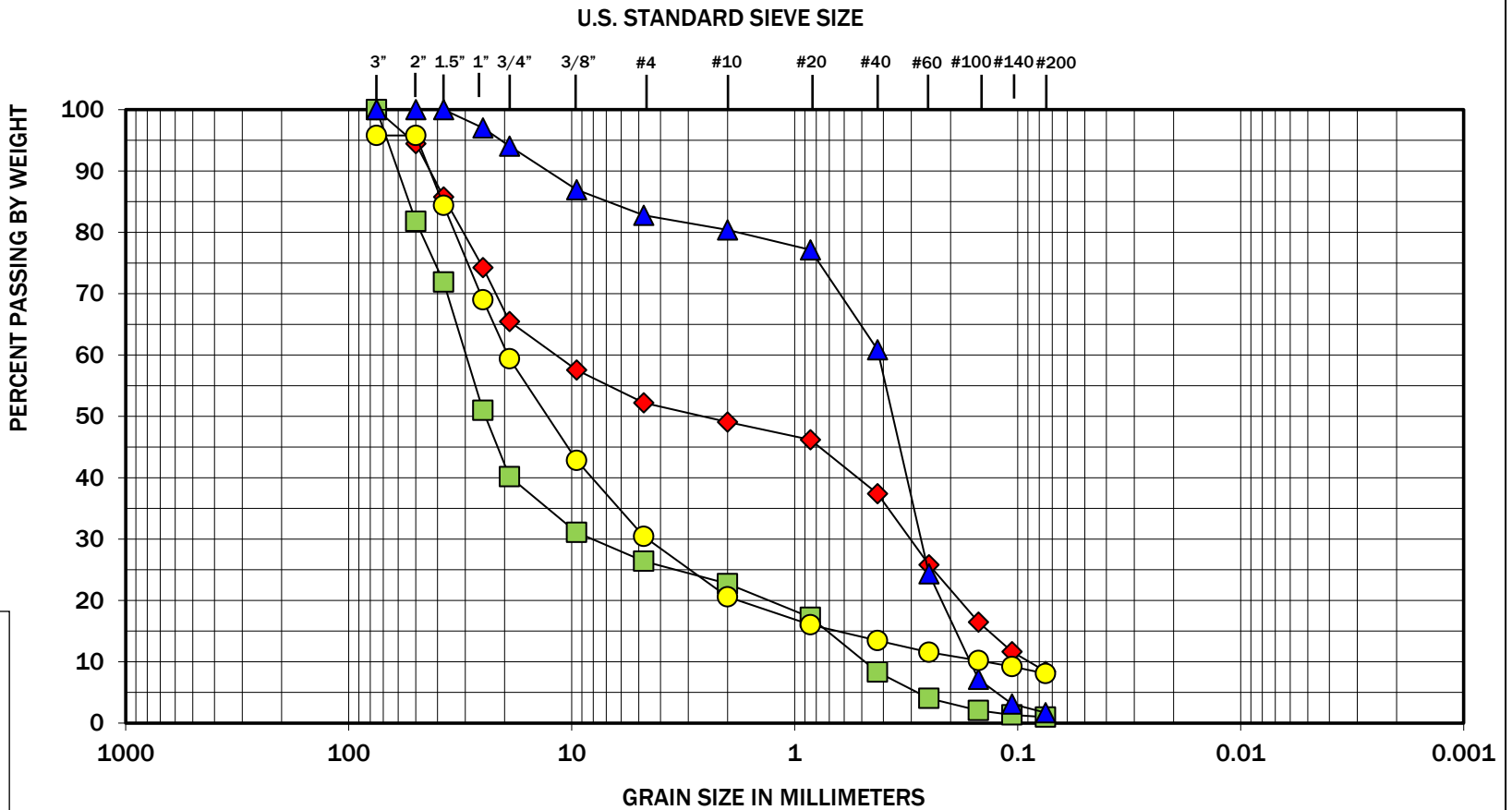

COBBLES	GRAVEL		SAND			SILT OR CLAY
	COARSE	FINE	COARSE	MEDIUM	FINE	

Symbol	Test Pit Number	Depth (feet)	Moisture (%)	Soil Description
◆	TB-4A	6	10	Poorly graded gravel with silt and sand (GP-GM)
■	TB-4C	3.5	3	Poorly graded gravel with sand (GP)
▲	TH-4A	6	6	Poorly graded sand with gravel (SP)
●	TH-4B	3	9	Poorly graded gravel with silt sand (GP-GM)



Note: This report may not be reproduced, except in full, without written approval of GeoEngineers, Inc. Test results are applicable only to the specific sample on which they were performed, and should not be interpreted as representative of any other samples obtained at other times, depths or locations, or generated by separate operations or processes.

The grain size analysis results were obtained in general accordance with ASTM C 136. GeoEngineers 17425 NE Union Hill Road Ste 250, Redmond, WA 98052

GEOENGINEERS

Area 4 Proposed Nisqually Access Area, Nisqually State Park
Pierce County, Washington

Sieve Analysis Results

Figure A-7

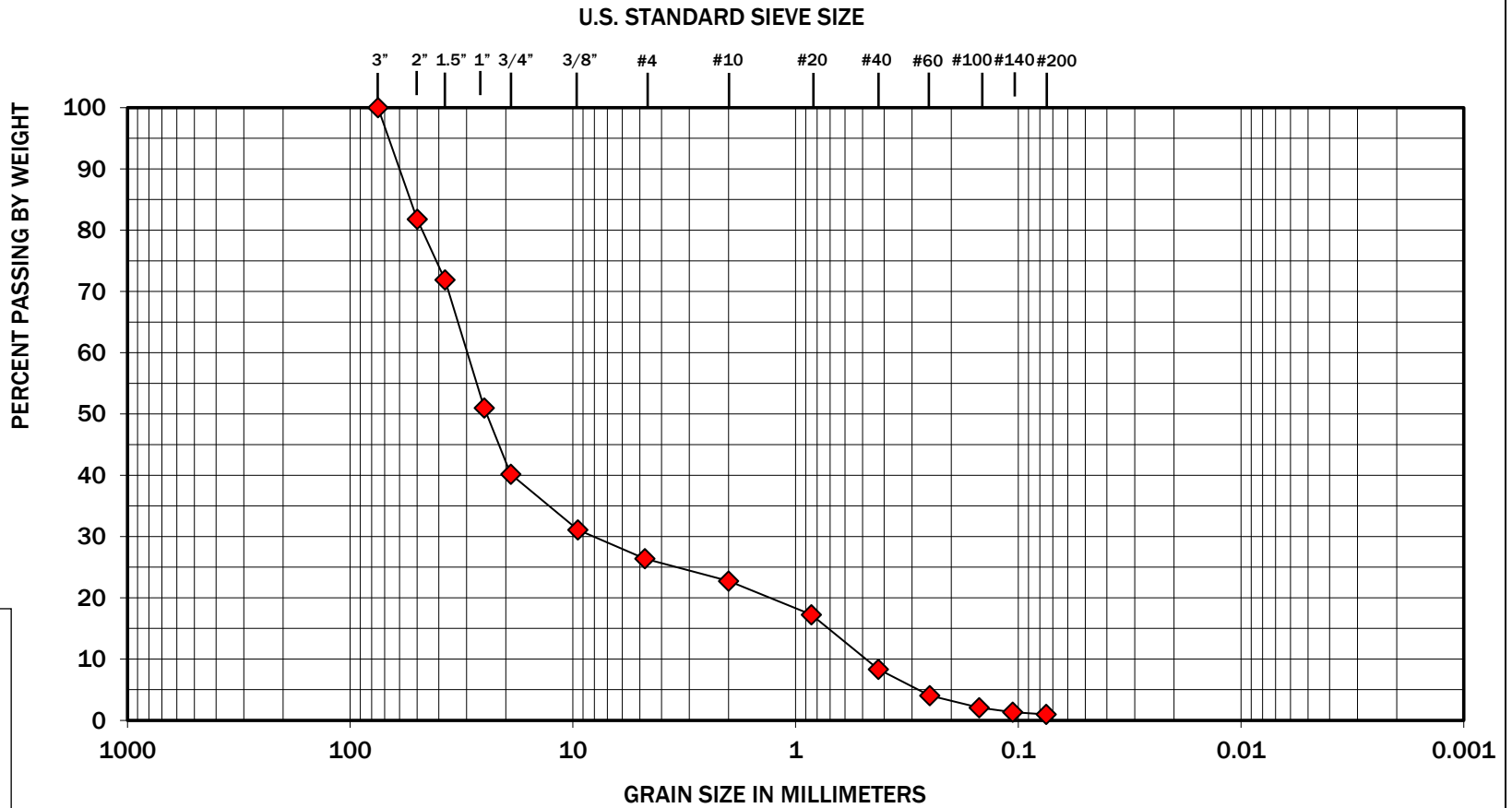

COBBLES	GRAVEL		SAND			SILT OR CLAY
	COARSE	FINE	COARSE	MEDIUM	FINE	

Symbol	Boring Number	Depth (feet)	Moisture (%)	Soil Description
◆	TH-4A	6	6	Poorly graded sand with gravel (SP)

GEOENGINEERS

Figure-A-8

Area 4 Proposed Nisqually Access Area, Nisqually State Park
Pierce County, Washington

Sieve Analysis Results



Note: This report may not be reproduced, except in full, without written approval of GeoEngineers, Inc. Test results are applicable only to the specific sample on which they were performed, and should not be interpreted as representative of any other samples obtained at other times, depths or locations, or generated by separate operations or processes.

The grain size analysis results were obtained in general accordance with ASTM C 136. GeoEngineers 17425 NE Union Hill Road Ste 250, Redmond, WA 98052

APPENDIX B
Report Limitations and Guidelines for Use

APPENDIX B REPORT LIMITATIONS AND GUIDELINES FOR USE¹

This appendix provides information to help you manage your risks with respect to the use of this report.

Geotechnical Services Are Performed For Specific Purposes, Persons and Projects

This report has been prepared for the exclusive use of Robert Droll Landscape Architects and their authorized agents. This report is not intended for use by others, and the information contained herein is not applicable to other sites.

GeoEngineers structures our services to meet the specific needs of our clients. For example, a geotechnical or geologic study conducted for a civil engineer or architect may not fulfill the needs of a construction contractor or even another civil engineer or architect that are involved in the same project. Because each geotechnical or geologic study is unique, each geotechnical engineering or geologic report is unique, prepared solely for the specific client and project site. Our report is prepared for the exclusive use of our Client. No other party may rely on the product of our services unless we agree in advance to such reliance in writing. This is to provide our firm with reasonable protection against open-ended liability claims by third parties with whom there would otherwise be no contractual limits to their actions. Within the limitations of scope, schedule and budget, our services have been executed in accordance with our Agreement with the Client and generally accepted geotechnical practices in this area at the time this report was prepared. This report should not be applied for any purpose or project except the one originally contemplated.

A Geotechnical Engineering or Geologic Report is Based on a Unique Set of Project-Specific Factors

This report has been prepared for the state improvements within Area 4 of the Nisqually State Park site in Pierce County, Washington. GeoEngineers considered a number of unique, project-specific factors when establishing the scope of services for this project and report. Unless GeoEngineers specifically indicates otherwise, do not rely on this report if it was:

- not prepared for you,
- not prepared for your project,
- not prepared for the specific site explored, or
- completed before important project changes were made.

For example, changes that can affect the applicability of this report include those that affect:

- the function of the proposed structure;
- elevation, configuration, location, orientation or weight of the proposed structure;
- composition of the design team; or
- project ownership.

¹ Developed based on material provided by ASFE, Professional Firms Practicing in the Geosciences; www.asfe.org.

If important changes are made after the date of this report, GeoEngineers should be given the opportunity to review our interpretations and recommendations and provide written modifications or confirmation, as appropriate.

Subsurface Conditions Can Change

This report is based on conditions that existed at the time the study was performed. The findings and conclusions of this report may be affected by the passage of time, by manmade events such as construction on or adjacent to the site, or by natural events such as floods, earthquakes, slope instability or groundwater fluctuations. Always contact GeoEngineers before applying a report to determine if it remains applicable.

Most Geotechnical and Geologic Findings are Professional Opinions

Our interpretations of subsurface conditions are based on field observations from widely spaced sampling locations at the site. Site exploration identifies subsurface conditions only at those points where subsurface tests are conducted or samples are taken. GeoEngineers reviewed field and laboratory data and then applied our professional judgment to render an opinion about subsurface conditions throughout the site. Actual subsurface conditions may differ, sometimes significantly, from those indicated in this report. Our report, conclusions and interpretations should not be construed as a warranty of the subsurface conditions.

Geotechnical Engineering Report Recommendations are Not Final

Do not over-rely on the preliminary construction recommendations included in this report. These recommendations are not final, because they were developed principally from GeoEngineers' professional judgment and opinion. GeoEngineers' recommendations can be finalized only by observing actual subsurface conditions revealed during construction. GeoEngineers cannot assume responsibility or liability for this report's recommendations if we do not perform construction observation.

Sufficient monitoring, testing and consultation by GeoEngineers should be provided during construction to confirm that the conditions encountered are consistent with those indicated by the explorations, to provide recommendations for design changes should the conditions revealed during the work differ from those anticipated, and to evaluate whether or not earthwork activities are completed in accordance with our recommendations. Retaining GeoEngineers for construction observation for this project is the most effective method of managing the risks associated with unanticipated conditions.

A Geotechnical Engineering or Geologic Report Could be Subject to Misinterpretation

Misinterpretation of this report by other design team members can result in costly problems. You could lower that risk by having GeoEngineers confer with appropriate members of the design team after submitting the report. Also retain GeoEngineers to review pertinent elements of the design team's plans and specifications. Contractors can also misinterpret a geotechnical engineering or geologic report. Reduce that risk by having GeoEngineers participate in pre-bid and preconstruction conferences, and by providing construction observation.

Do Not Redraw the Exploration Logs

Geotechnical engineers and geologists prepare final boring and testing logs based upon their interpretation of field logs and laboratory data. To prevent errors or omissions, the logs included in a geotechnical engineering or geologic report should never be redrawn for inclusion in architectural or other design

drawings. Only photographic or electronic reproduction is acceptable, but recognize that separating logs from the report can elevate risk.

Give Contractors a Complete Report and Guidance

Some owners and design professionals believe they can make contractors liable for unanticipated subsurface conditions by limiting what they provide for bid preparation. To help prevent costly problems, give contractors the complete geotechnical engineering or geologic report, but preface it with a clearly written letter of transmittal. In that letter, advise contractors that the report was not prepared for purposes of bid development and that the report's accuracy is limited; encourage them to confer with GeoEngineers and/or to conduct additional study to obtain the specific types of information they need or prefer. A pre-bid conference can also be valuable. Be sure contractors have sufficient time to perform additional study. Only then might an owner be in a position to give contractors the best information available, while requiring them to at least share the financial responsibilities stemming from unanticipated conditions. Further, a contingency for unanticipated conditions should be included in your project budget and schedule.

Contractors are Responsible for Site Safety on Their Own Construction Projects

Our geotechnical recommendations are not intended to direct the contractor's procedures, methods, schedule or management of the work site. The contractor is solely responsible for job site safety and for managing construction operations to minimize risks to on-site personnel and to adjacent properties.

Read These Provisions Closely

Some clients, design professionals and contractors may not recognize that the geoscience practices (geotechnical engineering or geology) are far less exact than other engineering and natural science disciplines. This lack of understanding can create unrealistic expectations that could lead to disappointments, claims and disputes. GeoEngineers includes these explanatory "limitations" provisions in our reports to help reduce such risks. Please confer with GeoEngineers if you are unclear how these "Report Limitations and Guidelines for Use" apply to your project or site.

Geotechnical, Geologic and Environmental Reports Should Not be Interchanged

The equipment, techniques and personnel used to perform an environmental study differ significantly from those used to perform a geotechnical or geologic study and vice versa. For that reason, a geotechnical engineering or geologic report does not usually relate any environmental findings, conclusions or recommendations; e.g., about the likelihood of encountering underground storage tanks or regulated contaminants. Similarly, environmental reports are not used to address geotechnical or geologic concerns regarding a specific project.

Biological Pollutants

GeoEngineers' Scope of Work specifically excludes the investigation, detection, prevention, or assessment of the presence of Biological Pollutants in or around any structure. Accordingly, this report includes no interpretations, recommendations, findings, or conclusions for the purpose of detecting, preventing, assessing, or abating Biological Pollutants and no conclusions or inferences should be drawn regarding Biological Pollutants, as they may relate to this project. The term "Biological Pollutants" includes, but is not limited to, molds, fungi, spores, bacteria, and viruses, and/or any of their byproducts. If Client desires these specialized services, they should be obtained from a consultant who offers services in this specialized field.

To: Robert W. Droll, ASLA

From: Steve Helvey, LEG; Debra Overbay, PE

Date: February 14, 2024

File: 2935-067-06

Subject: Borrow Pit Soil Sample Analyses, Nisqually State Park

INTRODUCTION

This memorandum provides a summary of our observations and soil sample analyses for the Borrow Pit at the above-referenced site. The approximate location of the site is shown in Figure 1. The borrow pit layout is shown in Figure 2. We understand that you are considering use of borrow pit soils for use as Common Borrow fill. The fill will be used in various construction elements of the Nisqually Park development project.

SITE CONDITIONS

General

We have observed the borrow pit at various times during our work at the Nisqually Park site. We collected samples from the pit in December 2020 and January 2021. The results of that work were provided in our Technical Memorandum dated March 9, 2021.

The pit is located just north of a utility access road, that is oriented east-west through the Nisqually Park site. A headwall is located along the west, east and north perimeters of the borrow pit site. The easterly headwall is the current project focus. We understand soil from this area has been excavated since our previous work. Many piles of end-dumped soil exist at the toe of this slope, out into the borrow pit floor.

The westerly headwall slope is mostly unvegetated. Our approximate sampling locations are shown in Figure 2. Some downed trees are present in the approximate middle portion of the headway, between sample locations 2 and 3. We did not observe the presence of groundwater seepage at the site during our site visit.

Subsurface Conditions

Shallow soil conditions were evaluated at the borrow pit by collecting four hand samples on January 20, 2024. Laboratory results are presented in Appendix A.

Native outwash soils were encountered in the hand sample locations, below about 4 to 6 inches of colluvium material. Outwash in hand samples generally comprises sand and gravel with silt contents ranging from about 2 to 8 percent.

USE OF BORROW PIT SOILS

The borrow pit soils encountered in our hand explorations can be used as common borrow. Native outwash materials encountered contained a high percentage of gravel and low to moderate amount of fines. Most of this material is likely suitable for use as structural fill during dry and wet weather conditions. Materials encountered with more than about 7 percent fines will likely not be suitable for use as fill during wet conditions.

We recommend the surface covering of duff and topsoil be stripped in areas where borrow pit excavations occur. Stripping should expose the relatively clean recessional outwash material.

LIMITATIONS

We have prepared this memorandum for a portion of the Nisqually Park project. The opinions presented in this memorandum are based on assumed subsurface conditions within the borrow pit based on widely spaced shallow hand explorations and by limited laboratory testing. It is possible that subsurface conditions between our explorations differs from what was encountered at the sample locations.

Within the limitations of scope, schedule and budget, our services have been executed in accordance with generally accepted practices for geotechnical engineering services in this area at the time this memorandum was prepared. The conclusions, recommendations, and opinions presented in this memorandum are based on our professional knowledge, judgment and experience. No warranty, express or implied, applies to the services or this memorandum.

The limitations presented as Appendix B in our “Geotechnical Engineering Services Report–Area 4” dated March 5, 2021 also apply to this memorandum.

SWH:DCO:leh

Attachments:

Figure 1. Vicinity Map

Figure 2. Site Plan

Appendix A – Soil Sample Test Results.

Disclaimer: Any electronic form, facsimile or hard copy of the original document (email, text, table, and/or figure), if provided, and any attachments are only a copy of the original document. The original document is stored by GeoEngineers, Inc. and will serve as the official document of record.

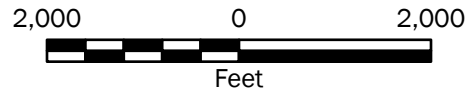
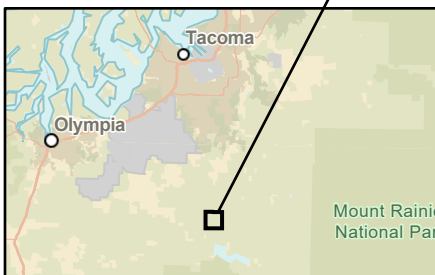
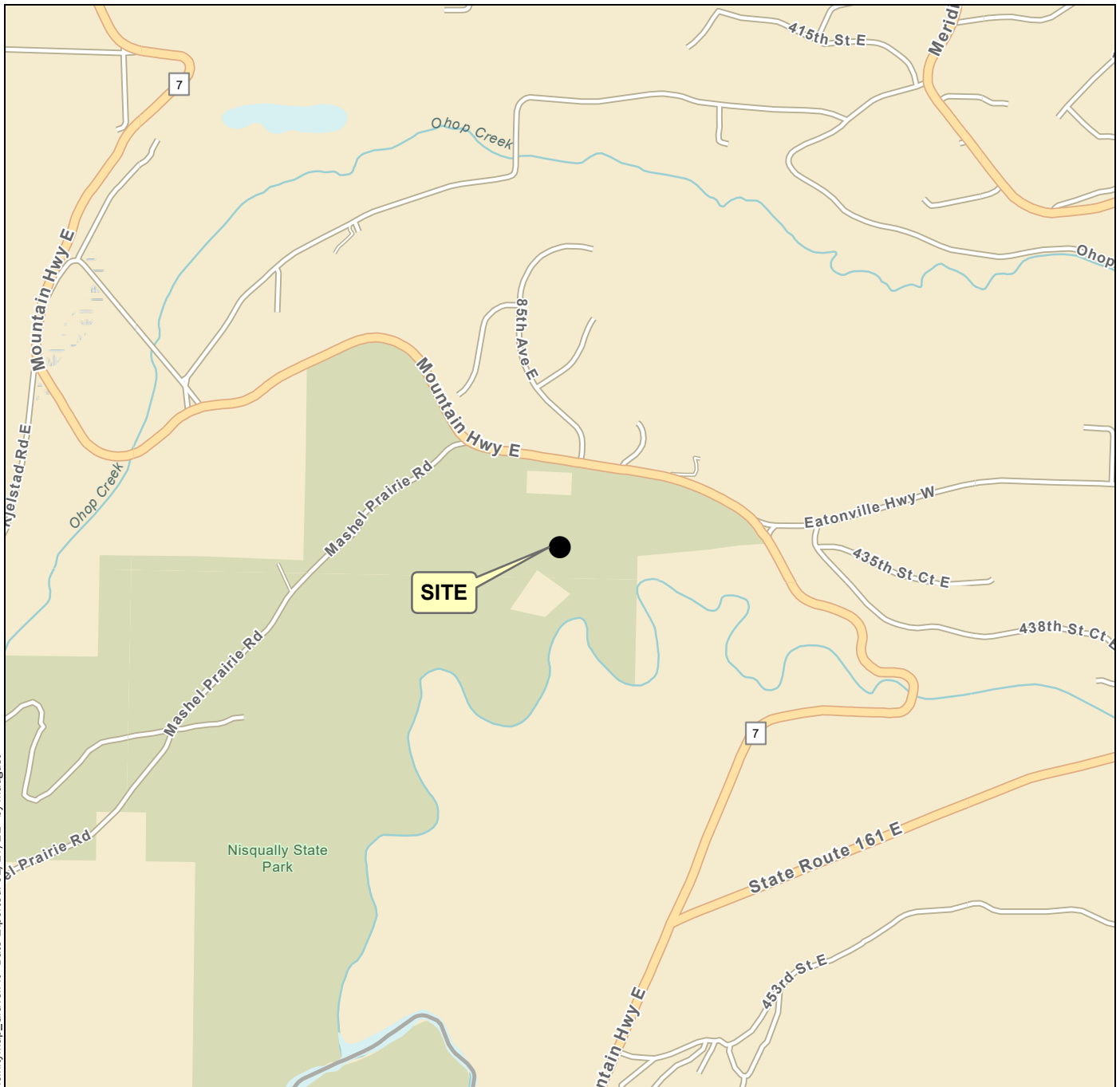

Vicinity Map

Borrow Pit Area - Nisqually State Park
Pierce County, Washington



Figure 1

Notes:

1. The locations of all features shown are approximate.
2. This drawing is for information purposes. It is intended to assist in showing features discussed in an attached document. GeoEngineers, Inc. cannot guarantee the accuracy and content of electronic files. The master file is stored by GeoEngineers, Inc. and will serve as the official record of this communication.

Data Source: ESRI

Projection: NAD 1983 StatePlane Washington North FIPS 4601 Feet

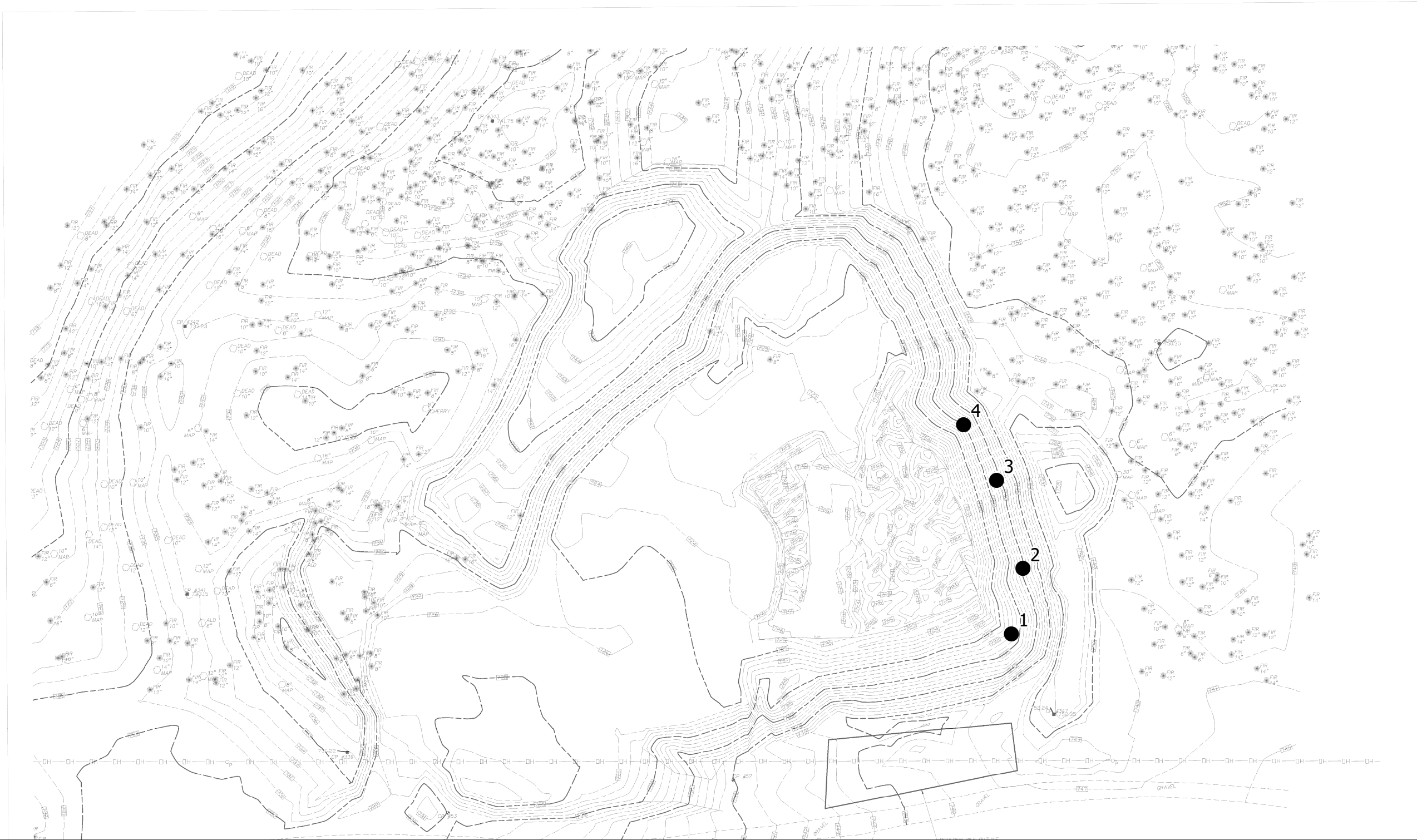

Legend

- Approximate Location of Surface Soil Sample

Coordinate System: NAD 1983 StatePlane Washington North FIPS 4601 Feet

Disclaimer: This figure was created for a specific purpose and project. Any use of this figure for any other project or purpose shall be at the user's sole risk and without liability to GeoEngineers. The locations of features shown may be approximate. GeoEngineers makes no warranty or representation as to the accuracy, completeness, or suitability of the figure, or data contained therein. The file containing this figure is a copy of a master document, the original of which is retained by GeoEngineers and is the official document of record.

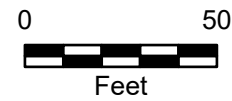

Site Plan

Borrow Pit Area - Nisqually State Park
Pierce County, Washington



Figure 2

APPENDIX A
Soil Sample Test Results



Sieve Report

Project: Nisqually State Park Project #: 2935-067-06 Client: GeoEngineers Source: Nisqually State Park - S-2 Sample#: S24-0016	Date Received: 23-Jan-24 Sampled By: Client Date Tested: 25-Jan-24 Tested By: C. Kirk-Patterson Control No.:	Unified Soil Classification System, ASTM-2487 SP-SM, Poorly graded Sand with Silt and Gravel Sample Color: Tan
---	---	---

Method(s) ASTM D-2216, ASTM D-2419, ASTM D4318, ASTM D-5281

Specifications

2022 WSDOT 9-03.14(3) Common Borrow
Sample Meets Specs ? Yes

D ₍₅₎ = 0.048 mm	% Gravel = 43.4%	Coeff. of Curvature, C _c = 0.83
D ₍₁₀₎ = 0.132 mm	% Sand = 48.8%	Coeff. of Uniformity, C _u = 46.05
D ₍₁₅₎ = 0.300 mm	% Silt & Clay = 7.8%	Fineness Modulus = 4.60
D ₍₃₀₎ = 0.814 mm	Liquid Limit = 0.0%	Plastic Limit = 0.0%
D ₍₅₀₎ = 3.115 mm	Plasticity Index = 0.0%	Moisture %, as sampled = 11.9%
D ₍₆₀₎ = 6.061 mm	Sand Equivalent = n/a	Req'd Sand Equivalent =
D ₍₉₀₎ = 28.569 mm	Fracture %, 1 Face = n/a	Req'd Fracture %, 1 Face =
Dust Ratio = 17/40	Fracture %, 2+ Faces = n/a	Req'd Fracture %, 2+ Faces =

Method(s) ASTM C-136, ASTM D-6913, ASTM C-117

Sieve Size		Actual Cumulative Percent Passing	Interpolated Cumulative Percent Passing	Specs Max	Specs Min
US	Metric				
12.00"	300.00		100%		
10.00"	250.00		100%		
8.00"	200.00		100%		
6.00"	150.00		100%		
4.00"	100.00		100%		
3.00"	75.00		100%		
2.50"	63.00		100%		
2.00"	50.00	100%	100%		
1.75"	45.00		98%		
1.50"	37.50	95%	95%		
1.25"	31.50		92%		
1.00"	25.00	88%	88%		
3/4"	19.00	83%	83%		
5/8"	16.00		79%		
1/2"	12.50	74%	74%		
3/8"	9.50	69%	69%		
1/4"	6.30		61%		
#4	4.75	57%	57%		
#8	2.36	47%	47%		
#10	2.00	45%	45%		
#16	1.18		35%		
#20	0.850	31%	31%		
#30	0.600		24%		
#40	0.425	18%	18%		
#50	0.300		15%		
#60	0.250	14%	14%		
#80	0.180	12%	12%		
#100	0.150	11%	11%		
#140	0.106		9%		
#170	0.090		8%		
#200	0.075	7.8%	7.8%	15.0%	0.0%

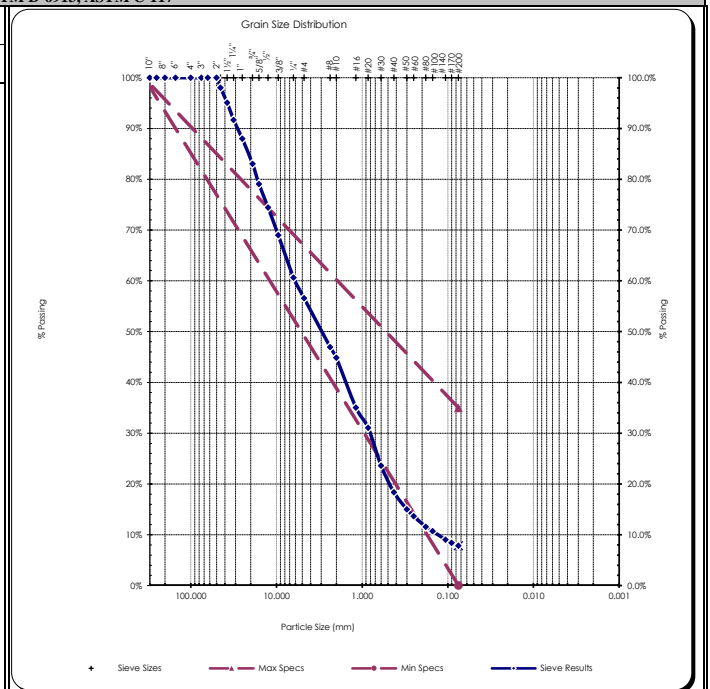

Copyright Spears Engineering & Technical Services PS, 1996-98

All results apply only to actual locations and materials tested. As a mutual protection to clients, the public and ourselves, all reports are submitted as the confidential property of clients, and authorization for publication of statements, conclusions or extracts from or regarding our reports is reserved pending our written approval.

Comments: Sample 2 of 4

Reviewed by: Mark Peterson
 Name
 WABO Supervising Laboratory Technician



Sieve Report

Project: Nisqually State Park Project #: 2935-067-06 Client: GeoEngineers Source: Nisqually State Park - S-3 Sample#: S24-0017	Date Received: 23-Jan-24 Sampled By: Client Date Tested: 25-Jan-24 Tested By: C. Kirk-Patterson Control No.:	Unified Soil Classification System, ASTM-2487 SW-SM, Well-graded Sand with Silt and Gravel Sample Color: Tan
---	---	---

Method(s) ASTM D-2216, ASTM D-2419, ASTM D4318, ASTM D-5281

Specifications

2022 WSDOT 9-03.14(3) Common Borrow
Sample Meets Specs ? Yes

D ₍₅₎ = 0.055 mm	% Gravel = 41.0%	Coeff. of Curvature, C _c = 1.04
D ₍₁₀₎ = 0.132 mm	% Sand = 52.2%	Coeff. of Uniformity, C _u = 38.60
D ₍₁₅₎ = 0.245 mm	% Silt & Clay = 6.8%	Fineness Modulus = 4.49
D ₍₃₀₎ = 0.837 mm	Liquid Limit = 0.0%	Plastic Limit = 0.0%
D ₍₅₀₎ = 2.396 mm	Plasticity Index = 0.0%	Moisture %, as sampled = 9.5%
D ₍₆₀₎ = 5.109 mm	Sand Equivalent = n/a	Req'd Sand Equivalent =
D ₍₉₀₎ = 23.450 mm	Fracture %, 1 Face = n/a	Req'd Fracture %, 1 Face =
Dust Ratio = 10/29	Fracture %, 2+ Faces = n/a	Req'd Fracture %, 2+ Faces =

Method(s) ASTM C-136, ASTM D-6913, ASTM C-117

Sieve Size		Actual Cumulative Percent Passing	Interpolated Cumulative Percent Passing	Specs Max	Specs Min
US	Metric				
12.00"	300.00		100%		
10.00"	250.00		100%		
8.00"	200.00		100%		
6.00"	150.00		100%		
4.00"	100.00		100%		
3.00"	75.00		100%		
2.50"	63.00		100%		
2.00"	50.00	98%	98%		
1.75"	45.00		98%		
1.50"	37.50	97%	97%		
1.25"	31.50		95%		
1.00"	25.00	92%	92%		
3/4"	19.00	85%	85%		
5/8"	16.00		82%		
1/2"	12.50	77%	77%		
3/8"	9.50	72%	72%		
1/4"	6.30		63%		
#4	4.75	59%	59%		
#8	2.36	50%	50%		
#10	2.00	47%	47%		
#16	1.18		35%		
#20	0.850	30%	30%		
#30	0.600		24%		
#40	0.425	20%	20%		
#50	0.300		16%		
#60	0.250	15%	15%		
#80	0.180	12%	12%		
#100	0.150	11%	11%		
#140	0.106		9%		
#170	0.090		8%		
#200	0.075	6.8%	6.8%	15.0%	0.0%

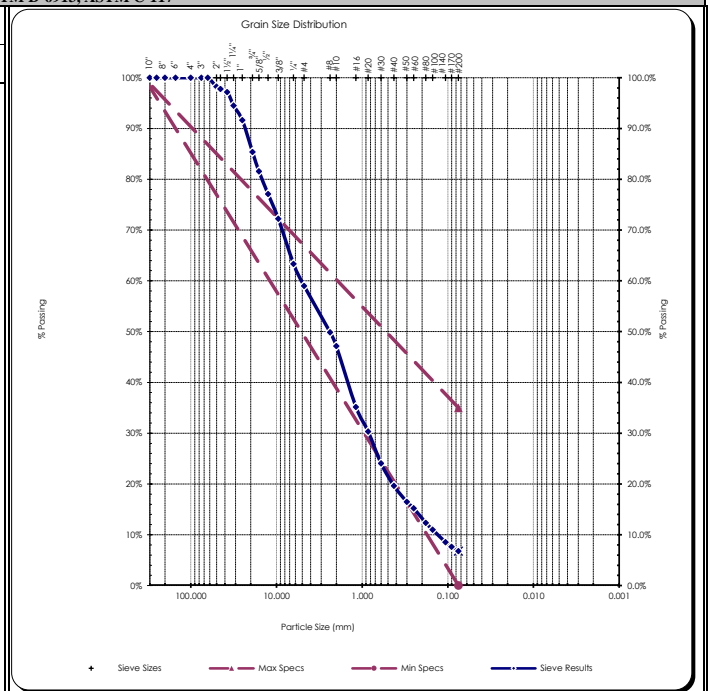

Copyright Spears Engineering & Technical Services PS, 1996-98

All results apply only to actual locations and materials tested. As a mutual protection to clients, the public and ourselves, all reports are submitted as the confidential property of clients, and authorization for publication of statements, conclusions or extracts from or regarding our reports is reserved pending our written approval.

Comments: Sample 3 of 4

Reviewed by: Mark Peterson
 Name
 WABO Supervising Laboratory Technician



Sieve Report

Project: Nisqually State Park Project #: 2935-067-06 Client: GeoEngineers Source: Nisqually State Park - S-4 Sample#: S24-0018	Date Received: 23-Jan-24 Sampled By: Client Date Tested: 25-Jan-24 Tested By: C. Kirk-Patterson Control No.:	Unified Soil Classification System, ASTM-2487 GP, Poorly graded Gravel with Sand Sample Color: Tan
---	---	---

Method(s) ASTM D-2216, ASTM D-2419, ASTM D4318, ASTM D-5281

Specifications

2022 WSDOT 9-03.14(3) Common Borrow
Sample Meets Specs ? Yes

D ₍₅₎ = 0.302 mm	% Gravel = 61.9%	Coeff. of Curvature, C _c = 0.98
D ₍₁₀₎ = 0.583 mm	% Sand = 35.9%	Coeff. of Uniformity, C _u = 19.63
D ₍₁₅₎ = 0.829 mm	% Silt & Clay = 2.1%	Fineness Modulus = 5.73
D ₍₃₀₎ = 2.554 mm	Liquid Limit = n/a	Plastic Limit = n/a
D ₍₅₀₎ = 8.378 mm	Plasticity Index = n/a	Moisture %, as sampled = 4.0%
D ₍₆₀₎ = 11.449 mm	Sand Equivalent = n/a	Req'd Sand Equivalent =
D ₍₉₀₎ = 36.717 mm	Fracture %, 1 Face = n/a	Req'd Fracture %, 1 Face =
Dust Ratio = 21/67	Fracture %, 2+ Faces = n/a	Req'd Fracture %, 2+ Faces =

Method(s) ASTM C-136, ASTM D-6913, ASTM C-117

Sieve Size		Actual Cumulative Percent Passing	Interpolated Cumulative Percent Passing	Specs	
				Max	Min
US	Metric				
12.00"	300.00		100%		
10.00"	250.00		100%		
8.00"	200.00		100%		
6.00"	150.00		100%		
4.00"	100.00		100%		
3.00"	75.00	94%	94%		
2.50"	63.00		93%		
2.00"	50.00	92%	92%		
1.75"	45.00		91%		
1.50"	37.50	90%	90%		
1.25"	31.50		87%		
1.00"	25.00	83%	83%		
3/4"	19.00	76%	76%		
5/8"	16.00		70%		
1/2"	12.50	63%	63%		
3/8"	9.50	54%	54%		
1/4"	6.30		43%		
#4	4.75	38%	38%		
#8	2.36	29%	29%		
#10	2.00	27%	27%		
#16	1.18		19%		
#20	0.850	15%	15%		
#30	0.600		10%		
#40	0.425	7%	7%		
#50	0.300		5%		
#60	0.250	4%	4%		
#80	0.180	3%	3%		
#100	0.150	3%	3%		
#140	0.106		3%		
#170	0.090		2%		
#200	0.075	2.1%	2.1%	15.0%	0.0%

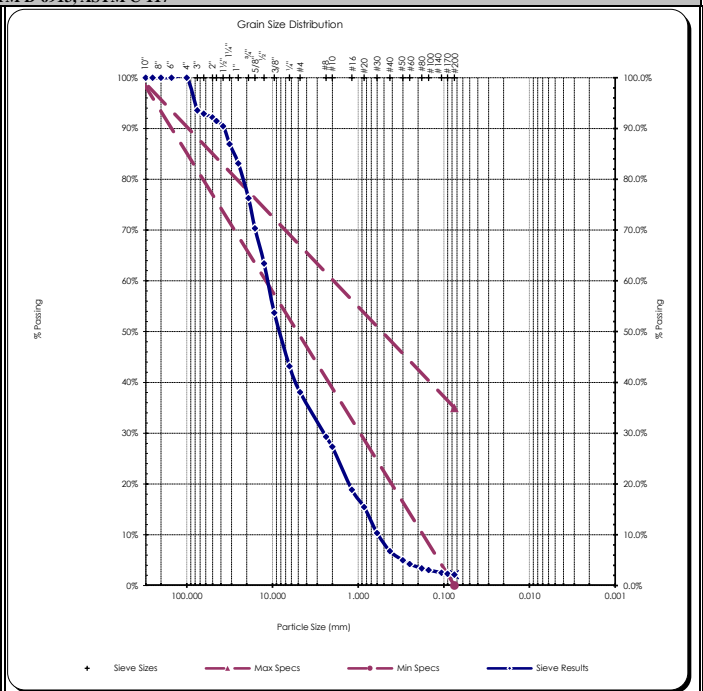

Copyright Spears Engineering & Technical Services PS, 1996-98

All results apply only to actual locations and materials tested. As a mutual protection to clients, the public and ourselves, all reports are submitted as the confidential property of clients, and authorization for publication of statements, conclusions or extracts from or regarding our reports is reserved pending our written approval.

Comments: Sample 4 of 4

Reviewed by: Mark Peterson
 Name
 WABO Supervising Laboratory Technician



Sieve Report

Project: Nisqually State Park Project #: 2935-067-06 Client: GeoEngineers Source: Nisqually State Park - S-1 Sample#: S24-0019	Date Received: 23-Jan-24 Sampled By: Client Date Tested: 25-Jan-24 Tested By: C. Kirk-Patterson Control No.:	Unified Soil Classification System, ASTM-2487 GW, Well-graded Gravel with Sand Sample Color: Tan
---	---	---

Method(s) ASTM D-2216, ASTM D-2419, ASTM D4318, ASTM D-5281

Specifications

2022 WSDOT 9-03.14(3) Common Borrow
Sample Meets Specs ? Yes

D ₍₅₎ = 0.228 mm	% Gravel = 72.3%	Coeff. of Curvature, C _c = 1.72
D ₍₁₀₎ = 0.802 mm	% Sand = 24.5%	Coeff. of Uniformity, C _u = 30.93
D ₍₁₅₎ = 1.520 mm	% Silt & Clay = 3.3%	Fineness Modulus = 6.52
D ₍₃₀₎ = 5.855 mm	Liquid Limit = n/a	Plastic Limit = n/a
D ₍₅₀₎ = 18.060 mm	Plasticity Index = n/a	Moisture %, as sampled = 5.4%
D ₍₆₀₎ = 24.795 mm	Sand Equivalent = n/a	Req'd Sand Equivalent =
D ₍₉₀₎ = 83.619 mm	Fracture %, 1 Face = n/a	Req'd Fracture %, 1 Face =
Dust Ratio = 21/44	Fracture %, 2+ Faces = n/a	Req'd Fracture %, 2+ Faces =

Method(s) ASTM C-136, ASTM D-6913, ASTM C-117

Sieve Size		Actual Cumulative Percent Passing	Interpolated Cumulative Percent Passing	Specs	
				Max	Min
US	Metric				
12.00"	300.00		100%		
10.00"	250.00		100%		
8.00"	200.00		100%		
6.00"	150.00		100%		
4.00"	100.00		100%		
3.00"	75.00	85%	85%		
2.50"	63.00		83%		
2.00"	50.00	80%	80%		
1.75"	45.00		77%		
1.50"	37.50	73%	73%		
1.25"	31.50		67%		
1.00"	25.00	60%	60%		
3/4"	19.00	51%	51%		
5/8"	16.00		47%		
1/2"	12.50	42%	42%		
3/8"	9.50	37%	37%		
1/4"	6.30		31%		
#4	4.75	28%	28%		
#8	2.36	20%	20%		
#10	2.00	18%	18%		
#16	1.18		13%		
#20	0.850		10%		
#30	0.600	9%	9%		
#40	0.425	7%	7%		
#50	0.300		6%		
#60	0.250		5%		
#80	0.180		5%		
#100	0.150	4%	4%		
#140	0.106		4%		
#170	0.090		3%		
#200	0.075	3.3%	3.3%	15.0%	0.0%

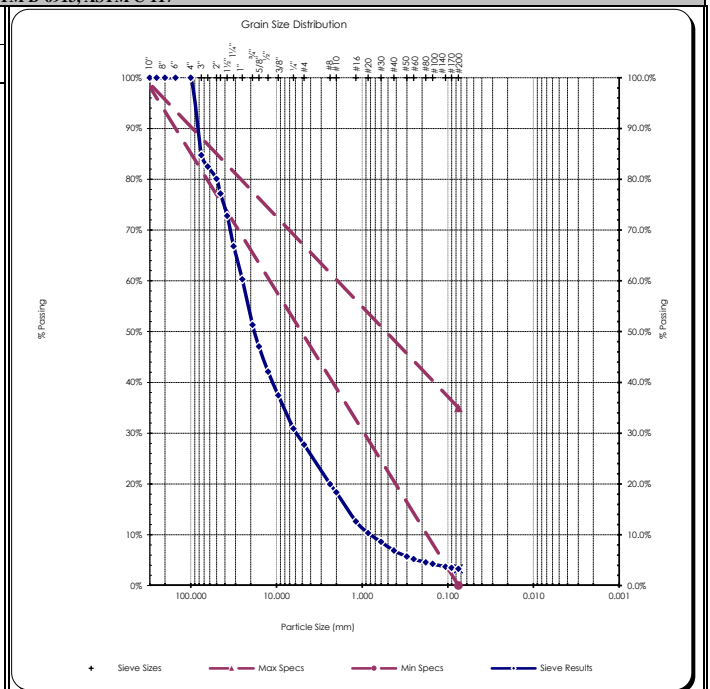

Copyright Spears Engineering & Technical Services PS, 1996-98

All results apply only to actual locations and materials tested. As a mutual protection to clients, the public and ourselves, all reports are submitted as the confidential property of clients, and authorization for publication of statements, conclusions or extracts from or regarding our reports is reserved pending our written approval.

Comments: Sample # 1 of 4

Reviewed by: Mark Peterson
 Name
 WABO Supervising Laboratory Technician

To: Robert W. Droll, ASLA

From: Steve Helvey, LEG; Debra Overbay, PE

Date: February 14, 2024

File: 2935-067-06

Subject: Borrow Pit Soil Sample Analyses, Nisqually State Park

INTRODUCTION

This memorandum provides a summary of our observations and soil sample analyses for the Borrow Pit at the above-referenced site. The approximate location of the site is shown in Figure 1. The borrow pit layout is shown in Figure 2. We understand that you are considering use of borrow pit soils for use as Common Borrow fill. The fill will be used in various construction elements of the Nisqually Park development project.

SITE CONDITIONS

General

We have observed the borrow pit at various times during our work at the Nisqually Park site. We collected samples from the pit in December 2020 and January 2021. The results of that work were provided in our Technical Memorandum dated March 9, 2021.

The pit is located just north of a utility access road, that is oriented east-west through the Nisqually Park site. A headwall is located along the west, east and north perimeters of the borrow pit site. The easterly headwall is the current project focus. We understand soil from this area has been excavated since our previous work. Many piles of end-dumped soil exist at the toe of this slope, out into the borrow pit floor.

The westerly headwall slope is mostly unvegetated. Our approximate sampling locations are shown in Figure 2. Some downed trees are present in the approximate middle portion of the headway, between sample locations 2 and 3. We did not observe the presence of groundwater seepage at the site during our site visit.

Subsurface Conditions

Shallow soil conditions were evaluated at the borrow pit by collecting four hand samples on January 20, 2024. Laboratory results are presented in Appendix A.

Native outwash soils were encountered in the hand sample locations, below about 4 to 6 inches of colluvium material. Outwash in hand samples generally comprises sand and gravel with silt contents ranging from about 2 to 8 percent.

USE OF BORROW PIT SOILS

The borrow pit soils encountered in our hand explorations can be used as common borrow. Native outwash materials encountered contained a high percentage of gravel and low to moderate amount of fines. Most of this material is likely suitable for use as structural fill during dry and wet weather conditions. Materials encountered with more than about 7 percent fines will likely not be suitable for use as fill during wet conditions.

We recommend the surface covering of duff and topsoil be stripped in areas where borrow pit excavations occur. Stripping should expose the relatively clean recessional outwash material.

LIMITATIONS

We have prepared this memorandum for a portion of the Nisqually Park project. The opinions presented in this memorandum are based on assumed subsurface conditions within the borrow pit based on widely spaced shallow hand explorations and by limited laboratory testing. It is possible that subsurface conditions between our explorations differs from what was encountered at the sample locations.

Within the limitations of scope, schedule and budget, our services have been executed in accordance with generally accepted practices for geotechnical engineering services in this area at the time this memorandum was prepared. The conclusions, recommendations, and opinions presented in this memorandum are based on our professional knowledge, judgment and experience. No warranty, express or implied, applies to the services or this memorandum.

The limitations presented as Appendix B in our “Geotechnical Engineering Services Report–Area 4” dated March 5, 2021 also apply to this memorandum.

SWH:DCO:leh

Attachments:

Figure 1. Vicinity Map

Figure 2. Site Plan

Appendix A – Soil Sample Test Results.

Disclaimer: Any electronic form, facsimile or hard copy of the original document (email, text, table, and/or figure), if provided, and any attachments are only a copy of the original document. The original document is stored by GeoEngineers, Inc. and will serve as the official document of record.

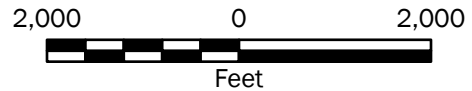
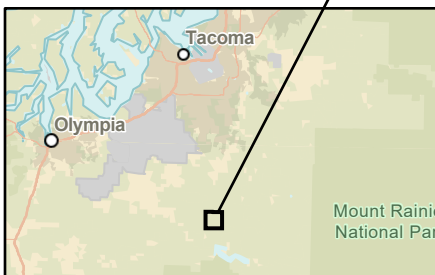
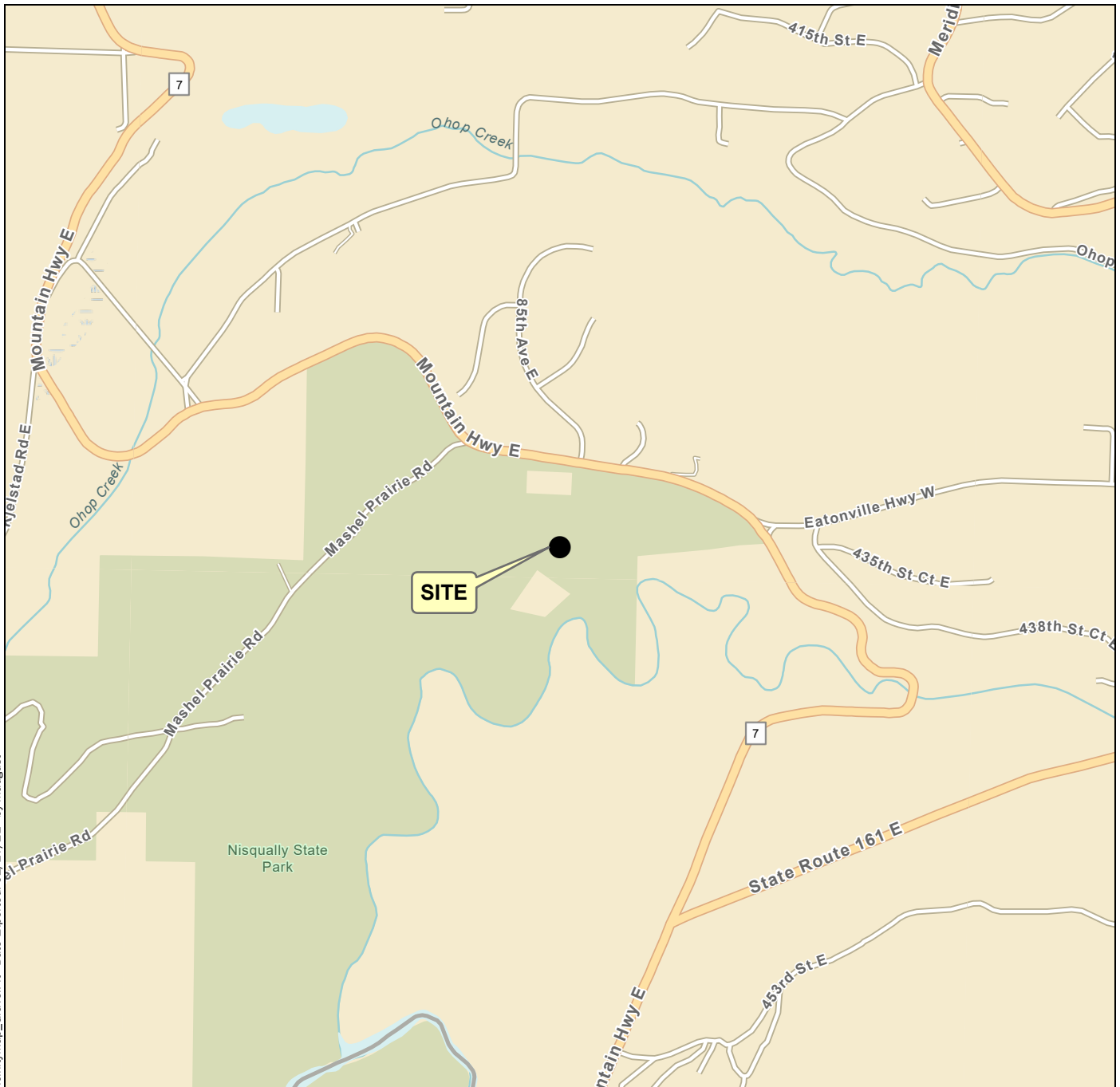

Vicinity Map

Borrow Pit Area - Nisqually State Park
Pierce County, Washington



Figure 1

Notes:

1. The locations of all features shown are approximate.
2. This drawing is for information purposes. It is intended to assist in showing features discussed in an attached document. GeoEngineers, Inc. cannot guarantee the accuracy and content of electronic files. The master file is stored by GeoEngineers, Inc. and will serve as the official record of this communication.

Data Source: ESRI

Projection: NAD 1983 StatePlane Washington North FIPS 4601 Feet

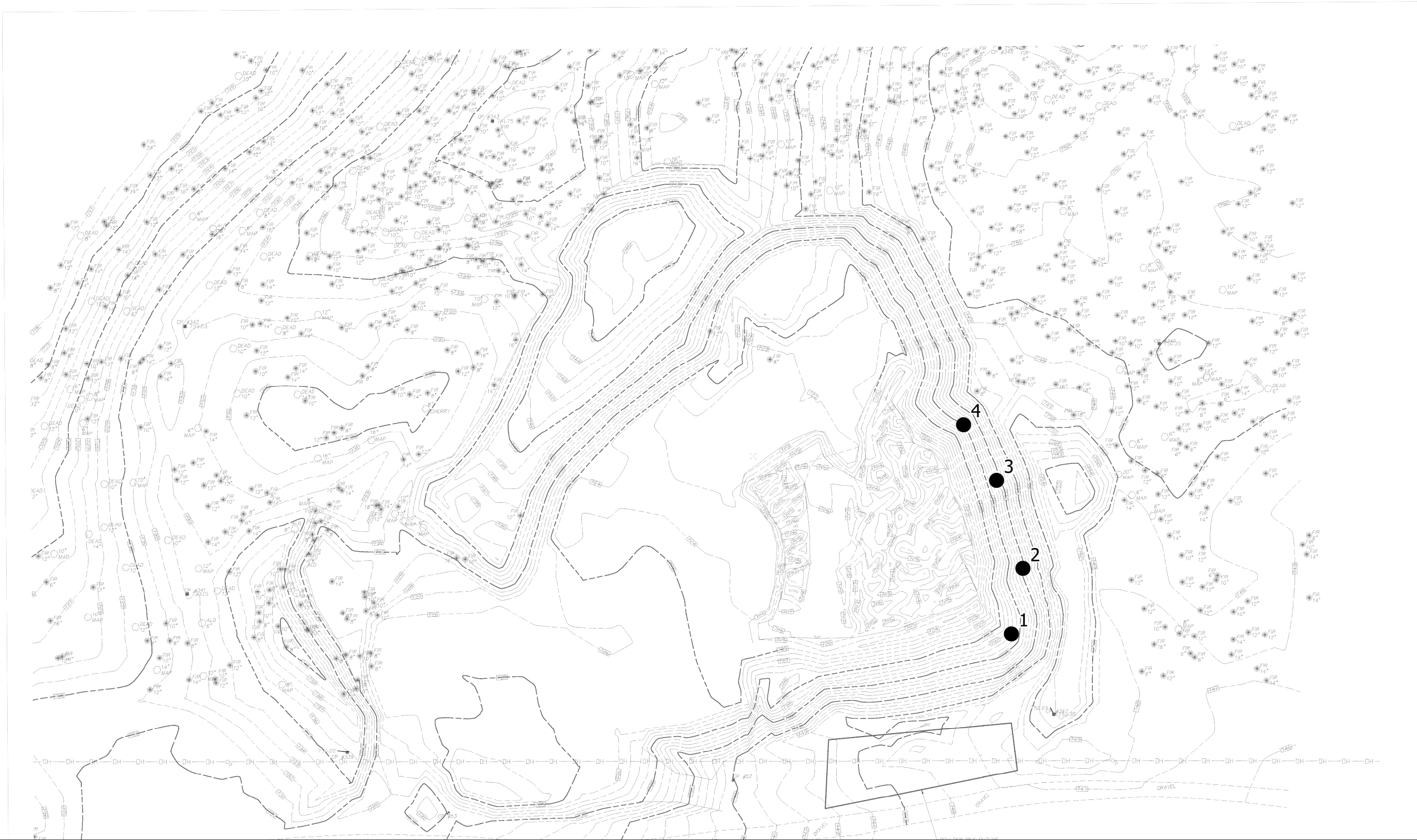

Legend

- Approximate Location of Surface Soil Sample

Coordinate System: NAD 1983 StatePlane Washington North FIPS 4601 Feet

Disclaimer: This figure was created for a specific purpose and project. Any use of this figure for any other project or purpose shall be at the user's sole risk and without liability to GeoEngineers. The locations of features shown may be approximate. GeoEngineers makes no warranty or representation as to the accuracy, completeness, or suitability of the figure, or data contained therein. The file containing this figure is a copy of a master document, the original of which is retained by GeoEngineers and is the official document of record.

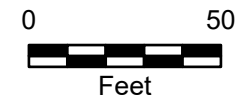

Site Plan

Borrow Pit Area - Nisqually State Park
Pierce County, Washington



Figure 2

APPENDIX A
Soil Sample Test Results



Sieve Report

Project: Nisqually State Park Project #: 2935-067-06 Client: GeoEngineers Source: Nisqually State Park - S-2 Sample#: S24-0016	Date Received: 23-Jan-24 Sampled By: Client Date Tested: 25-Jan-24 Tested By: C. Kirk-Patterson Control No.:	Unified Soil Classification System, ASTM-2487 SP-SM, Poorly graded Sand with Silt and Gravel Sample Color: Tan
---	---	---

Method(s) ASTM D-2216, ASTM D-2419, ASTM D4318, ASTM D-5281

Specifications

2022 WSDOT 9-03.14(3) Common Borrow
Sample Meets Specs ? Yes

D ₍₅₎ = 0.048 mm	% Gravel = 43.4%	Coeff. of Curvature, C _c = 0.83
D ₍₁₀₎ = 0.132 mm	% Sand = 48.8%	Coeff. of Uniformity, C _u = 46.05
D ₍₁₅₎ = 0.300 mm	% Silt & Clay = 7.8%	Fineness Modulus = 4.60
D ₍₃₀₎ = 0.814 mm	Liquid Limit = 0.0%	Plastic Limit = 0.0%
D ₍₅₀₎ = 3.115 mm	Plasticity Index = 0.0%	Moisture %, as sampled = 11.9%
D ₍₆₀₎ = 6.061 mm	Sand Equivalent = n/a	Req'd Sand Equivalent =
D ₍₉₀₎ = 28.569 mm	Fracture %, 1 Face = n/a	Req'd Fracture %, 1 Face =
Dust Ratio = 17/40	Fracture %, 2+ Faces = n/a	Req'd Fracture %, 2+ Faces =

Method(s) ASTM C-136, ASTM D-6913, ASTM C-117

Sieve Size		Actual Cumulative Percent Passing	Interpolated Cumulative Percent Passing	Specs Max	Specs Min
US	Metric				
12.00"	300.00		100%		
10.00"	250.00		100%		
8.00"	200.00		100%		
6.00"	150.00		100%		
4.00"	100.00		100%		
3.00"	75.00		100%		
2.50"	63.00		100%		
2.00"	50.00	100%	100%		
1.75"	45.00		98%		
1.50"	37.50	95%	95%		
1.25"	31.50		92%		
1.00"	25.00	88%	88%		
3/4"	19.00	83%	83%		
5/8"	16.00		79%		
1/2"	12.50	74%	74%		
3/8"	9.50	69%	69%		
1/4"	6.30		61%		
#4	4.75	57%	57%		
#8	2.36	47%	47%		
#10	2.00	45%	45%		
#16	1.18		35%		
#20	0.850	31%	31%		
#30	0.600		24%		
#40	0.425	18%	18%		
#50	0.300		15%		
#60	0.250	14%	14%		
#80	0.180	12%	12%		
#100	0.150	11%	11%		
#140	0.106		9%		
#170	0.090		8%		
#200	0.075	7.8%	7.8%	15.0%	0.0%

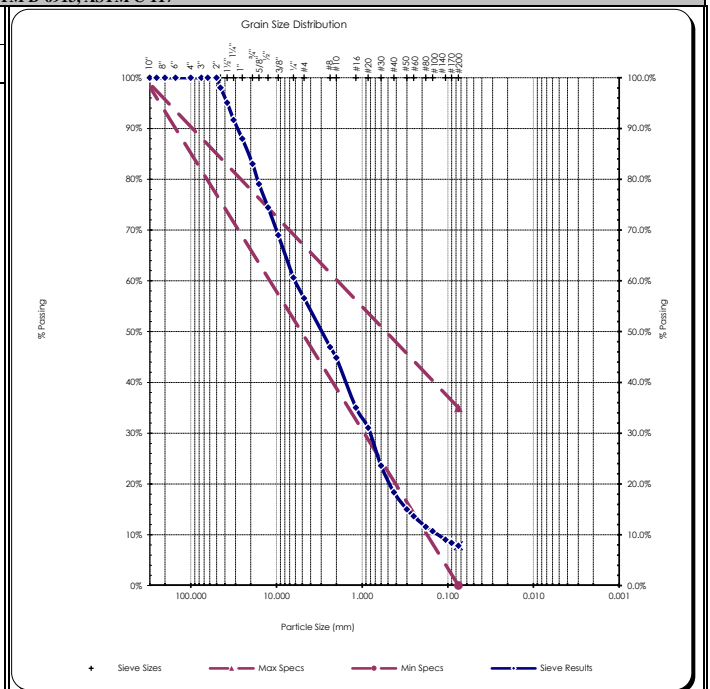

Copyright Spears Engineering & Technical Services PS, 1996-98

All results apply only to actual locations and materials tested. As a mutual protection to clients, the public and ourselves, all reports are submitted as the confidential property of clients, and authorization for publication of statements, conclusions or extracts from or regarding our reports is reserved pending our written approval.

Comments: Sample 2 of 4

Reviewed by: Mark Peterson
 Name
 WABO Supervising Laboratory Technician



Sieve Report

Project: Nisqually State Park Project #: 2935-067-06 Client: GeoEngineers Source: Nisqually State Park - S-3 Sample#: S24-0017	Date Received: 23-Jan-24 Sampled By: Client Date Tested: 25-Jan-24 Tested By: C. Kirk-Patterson Control No.:	Unified Soil Classification System, ASTM-2487 SW-SM, Well-graded Sand with Silt and Gravel Sample Color: Tan
---	---	---

Method(s) ASTM D-2216, ASTM D-2419, ASTM D4318, ASTM D-5281

Specifications

2022 WSDOT 9-03.14(3) Common Borrow
Sample Meets Specs ? Yes

D ₍₅₎ = 0.055 mm	% Gravel = 41.0%	Coeff. of Curvature, C _c = 1.04
D ₍₁₀₎ = 0.132 mm	% Sand = 52.2%	Coeff. of Uniformity, C _u = 38.60
D ₍₁₅₎ = 0.245 mm	% Silt & Clay = 6.8%	Fineness Modulus = 4.49
D ₍₃₀₎ = 0.837 mm	Liquid Limit = 0.0%	Plastic Limit = 0.0%
D ₍₅₀₎ = 2.396 mm	Plasticity Index = 0.0%	Moisture %, as sampled = 9.5%
D ₍₆₀₎ = 5.109 mm	Sand Equivalent = n/a	Req'd Sand Equivalent =
D ₍₉₀₎ = 23.450 mm	Fracture %, 1 Face = n/a	Req'd Fracture %, 1 Face =
Dust Ratio = 10/29	Fracture %, 2+ Faces = n/a	Req'd Fracture %, 2+ Faces =

Method(s) ASTM C-136, ASTM D-6913, ASTM C-117

Sieve Size		Actual Cumulative Percent Passing	Interpolated Cumulative Percent Passing	Specs Max	Specs Min
US	Metric				
12.00"	300.00		100%		
10.00"	250.00		100%		
8.00"	200.00		100%		
6.00"	150.00		100%		
4.00"	100.00		100%		
3.00"	75.00		100%		
2.50"	63.00		100%		
2.00"	50.00	98%	98%		
1.75"	45.00		98%		
1.50"	37.50	97%	97%		
1.25"	31.50		95%		
1.00"	25.00	92%	92%		
3/4"	19.00	85%	85%		
5/8"	16.00		82%		
1/2"	12.50	77%	77%		
3/8"	9.50	72%	72%		
1/4"	6.30		63%		
#4	4.75	59%	59%		
#8	2.36	50%	50%		
#10	2.00	47%	47%		
#16	1.18		35%		
#20	0.850	30%	30%		
#30	0.600		24%		
#40	0.425	20%	20%		
#50	0.300		16%		
#60	0.250	15%	15%		
#80	0.180	12%	12%		
#100	0.150	11%	11%		
#140	0.106		9%		
#170	0.090		8%		
#200	0.075	6.8%	6.8%	15.0%	0.0%

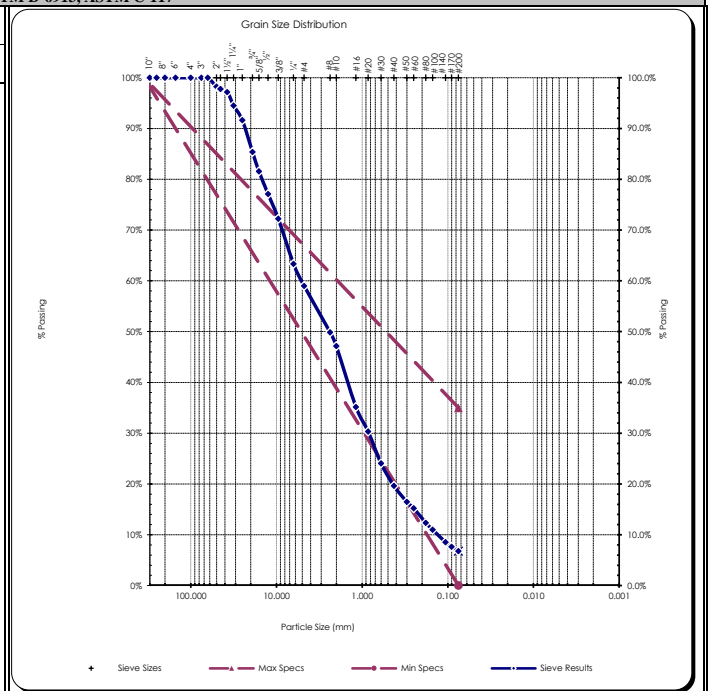

Copyright Spears Engineering & Technical Services PS, 1996-98

All results apply only to actual locations and materials tested. As a mutual protection to clients, the public and ourselves, all reports are submitted as the confidential property of clients, and authorization for publication of statements, conclusions or extracts from or regarding our reports is reserved pending our written approval.

Comments: Sample 3 of 4

Reviewed by: Mark Peterson
 Name
 WABO Supervising Laboratory Technician



Sieve Report

Project: Nisqually State Park Project #: 2935-067-06 Client: GeoEngineers Source: Nisqually State Park - S-4 Sample#: S24-0018	Date Received: 23-Jan-24 Sampled By: Client Date Tested: 25-Jan-24 Tested By: C. Kirk-Patterson Control No.:	Unified Soil Classification System, ASTM-2487 GP, Poorly graded Gravel with Sand Sample Color: Tan
---	---	---

Method(s) ASTM D-2216, ASTM D-2419, ASTM D4318, ASTM D-5281			
Specifications 2022 WSDOT 9-03.14(3) Common Borrow Sample Meets Specs ? Yes	D ₍₅₎ = 0.302 mm D ₍₁₀₎ = 0.583 mm D ₍₁₅₎ = 0.829 mm D ₍₃₀₎ = 2.554 mm D ₍₅₀₎ = 8.378 mm D ₍₆₀₎ = 11.449 mm D ₍₉₀₎ = 36.717 mm Dust Ratio = 21/67	% Gravel = 61.9% % Sand = 35.9% % Silt & Clay = 2.1% Liquid Limit = n/a Plasticity Index = n/a Sand Equivalent = n/a Fracture %, 1 Face = n/a Fracture %, 2+ Faces = n/a	Coeff. of Curvature, C _c = 0.98 Coeff. of Uniformity, C _u = 19.63 Fineness Modulus = 5.73 Plastic Limit = n/a Moisture %, as sampled = 4.0% Req'd Sand Equivalent = Req'd Fracture %, 1 Face = Req'd Fracture %, 2+ Faces =

Method(s) ASTM C-136, ASTM D-6913, ASTM C-117					
Sieve Size		Actual Cumulative Percent Passing	Interpolated Cumulative Percent Passing	Specs	
US	Metric			Max	Min
12.00"	300.00		100%		
10.00"	250.00		100%		
8.00"	200.00		100%		
6.00"	150.00		100%		
4.00"	100.00		100%		
3.00"	75.00	94%	94%		
2.50"	63.00		93%		
2.00"	50.00	92%	92%		
1.75"	45.00		91%		
1.50"	37.50	90%	90%		
1.25"	31.50		87%		
1.00"	25.00	83%	83%		
3/4"	19.00	76%	76%		
5/8"	16.00		70%		
1/2"	12.50	63%	63%		
3/8"	9.50	54%	54%		
1/4"	6.30		43%		
#4	4.75	38%	38%		
#8	2.36	29%	29%		
#10	2.00	27%	27%		
#16	1.18		19%		
#20	0.850	15%	15%		
#30	0.600		10%		
#40	0.425	7%	7%		
#50	0.300		5%		
#60	0.250	4%	4%		
#80	0.180	3%	3%		
#100	0.150	3%	3%		
#140	0.106		3%		
#170	0.090		2%		
#200	0.075	2.1%	2.1%	15.0%	0.0%

Grain Size Distribution

+ Sieve Sizes - - - Max Specs - - - Min Specs - - - Sieve Results

Copyright Spears Engineering & Technical Services PS, 1996-98
 All results apply only to actual locations and materials tested. As a mutual protection to clients, the public and ourselves, all reports are submitted as the confidential property of clients, and authorization for publication of statements, conclusions or extracts from or regarding our reports is reserved pending our written approval.

Comments: Sample 4 of 4

Reviewed by: Mark Peterson
 Name
 WABO Supervising Laboratory Technician



Sieve Report

Project: Nisqually State Park Project #: 2935-067-06 Client: GeoEngineers Source: Nisqually State Park - S-1 Sample#: S24-0019	Date Received: 23-Jan-24 Sampled By: Client Date Tested: 25-Jan-24 Tested By: C. Kirk-Patterson Control No.:	Unified Soil Classification System, ASTM-2487 GW, Well-graded Gravel with Sand Sample Color: Tan
---	---	---

Method(s) ASTM D-2216, ASTM D-2419, ASTM D4318, ASTM D-5281

Specifications

2022 WSDOT 9-03.14(3) Common Borrow
Sample Meets Specs ? Yes

D ₍₅₎ = 0.228 mm	% Gravel = 72.3%	Coeff. of Curvature, C _c = 1.72
D ₍₁₀₎ = 0.802 mm	% Sand = 24.5%	Coeff. of Uniformity, C _u = 30.93
D ₍₁₅₎ = 1.520 mm	% Silt & Clay = 3.3%	Fineness Modulus = 6.52
D ₍₃₀₎ = 5.855 mm	Liquid Limit = n/a	Plastic Limit = n/a
D ₍₅₀₎ = 18.060 mm	Plasticity Index = n/a	Moisture %, as sampled = 5.4%
D ₍₆₀₎ = 24.795 mm	Sand Equivalent = n/a	Req'd Sand Equivalent =
D ₍₉₀₎ = 83.619 mm	Fracture %, 1 Face = n/a	Req'd Fracture %, 1 Face =
Dust Ratio = 21/44	Fracture %, 2+ Faces = n/a	Req'd Fracture %, 2+ Faces =

Method(s) ASTM C-136, ASTM D-6913, ASTM C-117

Sieve Size		Actual Cumulative Percent Passing	Interpolated Cumulative Percent Passing	Specs Max	Specs Min
US	Metric				
12.00"	300.00		100%		
10.00"	250.00		100%		
8.00"	200.00		100%		
6.00"	150.00		100%		
4.00"	100.00		100%		
3.00"	75.00	85%	85%		
2.50"	63.00		83%		
2.00"	50.00	80%	80%		
1.75"	45.00		77%		
1.50"	37.50	73%	73%		
1.25"	31.50		67%		
1.00"	25.00	60%	60%		
3/4"	19.00	51%	51%		
5/8"	16.00		47%		
1/2"	12.50	42%	42%		
3/8"	9.50	37%	37%		
1/4"	6.30		31%		
#4	4.75	28%	28%		
#8	2.36	20%	20%		
#10	2.00	18%	18%		
#16	1.18		13%		
#20	0.850		10%		
#30	0.600	9%	9%		
#40	0.425	7%	7%		
#50	0.300		6%		
#60	0.250		5%		
#80	0.180		5%		
#100	0.150	4%	4%		
#140	0.106		4%		
#170	0.090		3%		
#200	0.075	3.3%	3.3%	15.0%	0.0%

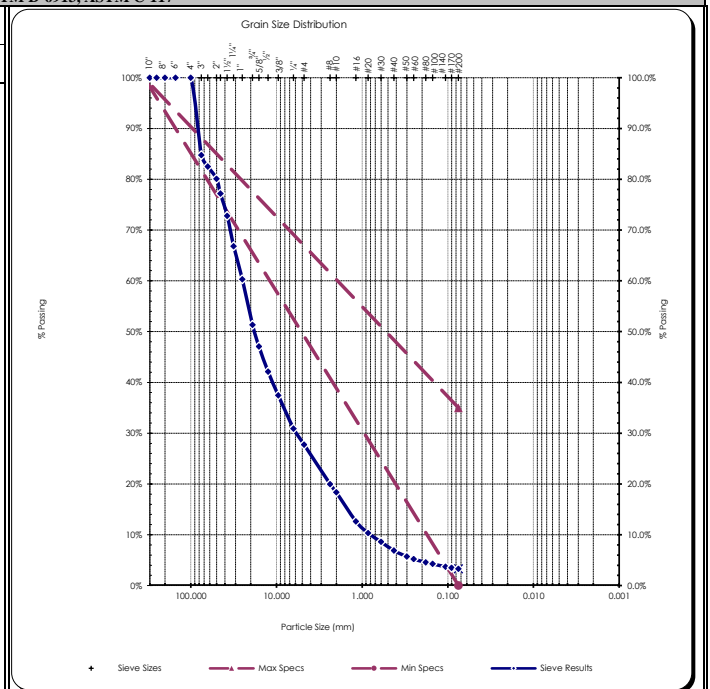

Copyright Spears Engineering & Technical Services PS, 1996-98

All results apply only to actual locations and materials tested. As a mutual protection to clients, the public and ourselves, all reports are submitted as the confidential property of clients, and authorization for publication of statements, conclusions or extracts from or regarding our reports is reserved pending our written approval.

Comments: Sample # 1 of 4

Reviewed by: Mark Peterson
 Name
 WABO Supervising Laboratory Technician

Geotechnical Engineering Services

Proposed Water Tank
Nisqually State Park
Pierce County, Washington

for

Robert W. Droll Landscape Architects

June 10, 2022



Geotechnical Engineering Services

Proposed Water Tank
Nisqually State Park
Pierce County, Washington

for

Robert W. Droll Landscape Architects

June 10, 2022



1101 South Fawcett Avenue, Suite 200
Tacoma, Washington 98402
253.383.4940

Geotechnical Engineering Services

Proposed Water Tank Nisqually State Park Pierce County, Washington

File No. 2935-067-01

June 10, 2022

Prepared for:

Robert W. Droll Landscape Architects
4405 7th Avenue SE, Suite 203
Lacey, Washington 98503

Attention: Bob Droll

Prepared by:

GeoEngineers, Inc.
1101 South Fawcett Avenue, Suite 200
Tacoma, Washington 98402
253.383.4940

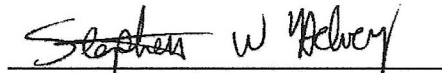

Stephen W. Helvey, LG, LEG, LHG
Senior Geologic Engineer

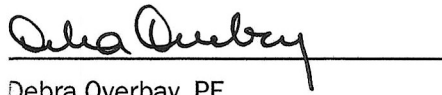

Debra Overbay, PE
Associate

SWH:DCO:leh

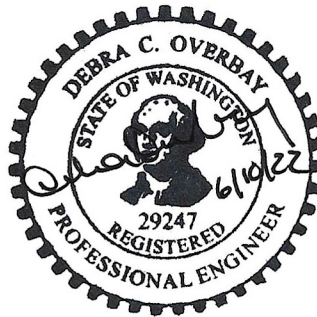

Disclaimer: Any electronic form, facsimile or hard copy of the original document (email, text, table, and/or figure), if provided, and any attachments are only a copy of the original document. The original document is stored by GeoEngineers, Inc. and will serve as the official document of record.

Table of Contents

1.0 INTRODUCTION	1
2.0 SCOPE OF SERVICES	1
3.0 SITE CONDITIONS	2
3.1. Surface Conditions.....	2
3.1.1. Geologic Conditions.....	2
3.1.2. Previous Explorations.....	2
3.2. Subsurface Explorations.....	2
3.3. Laboratory Testing	3
3.4. Soil Conditions	3
3.5. Groundwater Conditions.....	3
4.0 CONCLUSIONS AND RECOMMENDATIONS	3
4.1. General.....	3
4.2. Site Preparation and Earthwork.....	4
4.2.1. General.....	4
4.2.2. Stripping and Clearing.....	4
4.2.3. Subgrade Evaluation	5
4.2.4. Excavation.....	5
4.2.5. Excavation Support	5
4.2.6. Weather Considerations.....	5
4.2.7. Erosion and Sedimentation Control	6
4.3. Fill Materials.....	7
4.3.1. On-site Soils	7
4.3.2. Borrow Pit Soils.....	7
4.3.3. Select Granular Fill	7
4.3.4. Crushed Rock Base Layer	7
4.3.5. Pipe Bedding.....	7
4.4. Fill Placement and Compaction	7
4.4.1. General.....	7
4.4.2. Mat Foundation Base Rock	8
4.4.3. Area Fills and Bases.....	8
4.4.4. Trench Backfill.....	8
4.5. Temporary and Permanent Slopes	8
4.6. Tank Mat Foundation.....	9
4.7. Subgrade Modulus.....	9
4.8. Lateral Resistance	9
Seismic Design Parameters	9
4.8.1. Liquefaction Potential	10
5.0 LIMITATIONS	10

LIST OF FIGURES

Figure 1. Vicinity Map

Figure 2. Site Plan Area

Figure 3. Proposed Water Tank Site Plan

Figure 4. Key to Exploration Logs

Figure 5 through 7 Logs of Test Pits

Figure 8 Sieve Report Figure

APPENDICES

Appendix A. Previous Explorations

Appendix B. Report Limitations and Guidelines for Use

1.0 INTRODUCTION

This report presents the results of our geotechnical engineering services regarding a proposed concrete water tank at Nisqually State Park in Pierce County, Washington. The project site is located approximately as shown on the Vicinity Map, Figure 1. Our understanding of the project is based on information provided by KPFF Consulting Engineers (KPFF) and site visits in March and April 2022. Our services have been performed in general accordance with our proposal dated February 2, 2022. You authorized our services on March 4, 2022.

We understand the proposed water tank is to be of concrete construction and supported by a reinforced concrete mat foundation. We understand two tank configurations are being considered. If fire flow is not required, the tank will be about 26 feet in diameter and 20 feet tall. If fire flow is required, the tank will be about 30 feet in diameter and 45 feet tall.

The tank will be located generally west from the proposed site wastewater treatment plant (WWTP) and maintenance facility, as shown in Figure 2. A water well drilled in 2021 is located just northeast of the proposed tank area, as shown in Figure 3. A log of the well is included in Appendix A.

2.0 SCOPE OF SERVICES

The purpose of our services is to evaluate soil and groundwater conditions at the site as a basis for developing design criteria for geotechnical aspects of the proposed water tank. The specific scope of services completed for this project includes the following tasks:

1. Review existing geologic/geotechnical data for the site. This included the water well drilled northeast of the water tank site and explorations we advanced for the WWTP and Maintenance Building areas.
2. Subcontracting and observing the excavation of three test pits within the water tank area.
3. Logging soil and groundwater conditions observed in the test pit explorations. Collecting bulk soil samples from the test pits.
4. Performing moisture content and particle size distribution testing of the soil samples.
5. Evaluating pertinent physical and engineering characteristics of the site soils based on the results of the field explorations, laboratory tests and our experience.
6. Provide recommendations for water tank foundation support including:
 - Site preparation and subgrade improvements for the proposed mat foundation.
 - Allowable soil bearing pressure.
 - Settlement estimates.
 - Seismic design criteria based on International Building Code (IBC) considering the consistency of the deep borings completed at the park site.
 - Recommended lateral resistance design values.
 - Coefficient of base friction.
7. Provide recommendations for temporary and permanent cut and fill slope inclinations.
8. Discuss known or anticipated geotechnical issues that could influence construction, including wet weather considerations.

3.0 SITE CONDITIONS

3.1. Surface Conditions

The proposed water tank area is located west of the proposed WWTP area and south of the existing site water well. A gravel-surfaced access road is located east of the water tank site.

Water tank site topography is undulatory with a slight downward slope to the southwest and west. Undulations are likely due to the presence of near-surface boulders. The project area is currently covered in fir and alder trees and thick underbrush.

3.1.1. Geologic Conditions

Geologic conditions at the site and nearby area were evaluated by reviewing the Washington State Department of Natural Resources “Geologic Map of the Centralia Quadrangle, Washington, 1987.” Materials mapped in the site area comprise Vashon Drift, Undifferentiated (map unit Qdv). This material is mapped over a broad area at and around the project site. These geologic materials are described as glacial outwash with silts, clays, lacustrine deposits, and some ice contact deposits.

Mashel Formation sedimentary rocks (Tmh) are mapped beneath the Qdv material in the Ohop River valley wall, generally west of the site. Mashel Formation rocks are described as varying from claystone, sandstone to poorly cemented basaltic gravel.

3.1.2. Previous Explorations

We completed test pits and borings for the WWTP and Maintenance areas in previous phases of the project. The approximate locations of these explorations are shown in Figure 2. The nearby water well was drilled in July to August 2021 to a depth of 275 feet. The well log and logs of other explorations are included in Appendix A.

A thick layer of “till” was reported in the water well from about 7 to 58 feet in the boring. This material may be Mashel Formation bedrock. Similar materials were encountered in test pits and borings completed for the WWTP project.

3.2. Subsurface Explorations

We completed three test pits at the site on May 24, 2022. The approximate locations of the explorations are shown on Figure 3.

The test pits were completed using a small track-mounted excavator and locations were mapped using a portable graphical interface system (GIS) unit. Our representative continuously monitored the explorations, maintained a log of the subsurface conditions, and obtained representative samples, as needed. The soils encountered were visually classified in general accordance with ASTM International (ASTM) D 2488. A key to the symbols used on the test pit logs is included as Figure 4. The exploration logs are included as Figures 5 through 7.

3.3. Laboratory Testing

Soil samples obtained from the test pits were transported to a GeoEngineers laboratory. Soil samples were selected for laboratory tests to evaluate the pertinent geotechnical engineering characteristics of site soils and to confirm our field classification.

Moisture content and grain-size analyses were performed on selected samples in general accordance with ASTM Test Method D 422. This test method covers the quantitative determination of the distribution of particle sizes in soils. The test results were used to check field soil classifications. The result of the grain size analyses are presented in Figure 8.

3.4. Soil Conditions

About 6 to 12 inches of forest duff was encountered in each test pit. An approximate 6- to 24-inch thick layer of loose to medium dense silty sand was encountered below the duff. We interpret this material to be outwash.

Beneath the outwash we encountered medium dense to very dense silty gravel with boulders. We interpret this material to be glacial till. Each test pit met practical refusal in the till or weathered Mashel Formation at depths ranging from about 4 to 6 feet.

3.5. Groundwater Conditions

Slow groundwater seepage was encountered at a depth of 4 feet in test pit WT-2. Groundwater was not encountered in WT-1 and WT-3. We expect the depth to groundwater will vary seasonally with precipitation.

4.0 CONCLUSIONS AND RECOMMENDATIONS

4.1. General

Based on the project information and our investigation of subsurface conditions at the site, we conclude that the site is suitable for the proposed water tank. Dense to very dense glacial soils were encountered at shallow depths at the site. A summary of key geotechnical design issues is discussed below. The summary is presented for introductory purposes only and should be used in conjunction with the detailed recommendations presented in this report.

- We recommend Site Class D in accordance with International Building Code (IBC) 2018. Additional seismic design parameters are provided in a following section.
- The near-surface silty sand and silty gravel soils contain a moderate to high percentage of fines. These soils will be sensitive to small changes in moisture content and are susceptible to disturbance from construction traffic when the moisture content is more than a few percent above the optimum moisture content for compaction. These soils will be difficult, if not impossible, to work on or compact when wet and when earthwork is performed in wet weather. We recommend that earthwork only take place during extended periods of dry weather.
- Boulders were encountered in our explorations and were observed at the site and should be anticipated during grading activities and site excavations. Weakly cemented Mashel Formation bedrock (silt with sand/sand with silt) may also be encountered at depth at the site (below a depth of

about 4 to 5 feet). These materials are in a hard/very dense condition and the contractor should be prepared to remove this layer if deep excavations are required.

- Based on the results of laboratory tests the near-surface silty soils will not be suitable for re-use as structural fill without significant moisture conditioning. Clean gravel soils within the borrow pit may be suitable for fill during dry weather conditions.
- A minimum 6-inch-thick layer of crushed rock should be placed beneath the proposed mat foundation to provide a level foundation pad and prevent disturbance. A thicker layer will be appropriate to protect the subgrade if the subgrade becomes wet, to provide a level pad if considerable boulders are encountered and require removal, or to extend to the medium dense to dense native soils as recommended below. The subgrade should be clean and free of loose soil prior to placing the base rock.
- The proposed tank may be satisfactorily supported on a mat foundation supported on the medium dense to dense native soils or on crushed rock overlying these soils (anticipated to be encountered below a depth of 2 feet). As noted above, we recommend a minimum 6-inch base rock layer underlie the mat slab for uniform support. An allowable soil bearing pressure of 4,000 pounds per square foot (psf) can be used in design for the mat supported as recommended above. The contact depth of the supporting layer is interpreted from subsurface information obtained in our test pits. GeoEngineers should observe subgrade preparation to confirm that actual field conditions are consistent with our design recommendations.
- An allowable passive resistance on the face of embedded foundation elements may be computed using an equivalent fluid density of 250 pounds per cubic foot (pcf) for on-site medium dense native soils anticipated below a depth of 2 feet. This value can be increased to 350 pcf for the dense native soils encountered below a depth of 3 feet. The allowable frictional resistance may be computed using a coefficient of friction of 0.4 applied to vertical dead-load forces. The above passive equivalent fluid density values and coefficient of friction include a factor of safety of about 1.5.

4.2. Site Preparation and Earthwork

4.2.1. General

Site development will include removing existing trees and vegetation, stripping of forest duff/topsoil and root layer and removal of near-surface boulders. The site soils are moisture sensitive due to high fines content. Grading of these soils is only practical during the dry season (typically July through September). Moisture conditioning necessary to obtain proper compaction of these soils will likely not be practical during the cooler and wetter winter months and may still present challenges during the normally dry summer months. We recommend a contingency be included in the project budget and schedule for export of unsuitable wet on-site soil and import of select granular soil if earthwork will be performed during periods of wet weather.

The following sections provide our recommendations for earthwork, site development, and fill materials.

4.2.2. Stripping and Clearing

The existing trees, shrubs, topsoil, unsuitable soils, and boulders should be stripped and removed from the tank foundation area. Based on our explorations, the depth of stripping to remove unsuitable surface organic materials should generally vary between 6 and 12 inches. Greater stripping depths will be

required to remove localized zones of loose or organic-rich soil and tree roots and if large boulders are encountered. The primary root systems for trees and shrubs should be completely removed. Required stripping depths should be evaluated based on observations during the stripping operation. Stripped organic material should be transported off site for disposal or processed and used as fill in landscaping areas. Excavations for boulder depressions should be backfilled with structural fill compacted to the densities indicated in Section 4.3 “Fill Placement and Compaction” of this report.

4.2.3. Subgrade Evaluation

After stripping and excavation to planned subgrade is complete, we recommend the exposed soil be evaluated by the geotechnical engineer to confirm subsurface soils are consistent with the test pit explorations and our recommendations. The subgrade should expose the recommended foundation subgrade soils. If soft or otherwise unsuitable areas are encountered, these soils should be removed and replaced with compacted crushed rock as recommended by the engineer.

4.2.4. Excavation

Conventional earthmoving equipment in proper working order should be capable of making necessary excavations for utilities and the mat slab. We recommend that these excavations be performed using a smooth-blade bucket to prevent excessive disturbance of the excavation base.

Boulders were encountered in the explorations and were observed at the site and nearby areas and should be anticipated during grading and/or utility excavations. Accordingly, the contractor should be prepared to remove boulders, if encountered. Boulders may be removed from the site or buried in landscape areas. Voids caused by boulder removal must be backfilled with crushed rock structural fill.

4.2.5. Excavation Support

Shallow excavations (4 feet or less) in medium dense to dense deposits should stand at near vertical inclinations, provided groundwater seepage is not present in the cut face. Excavations deeper than 4 feet must be shored or laid back at a stable slope if workers are required to enter.

Shoring for utility excavations must conform with the provisions of Title 296 Washington Administrative Code (WAC), Part N, “Excavation, Trenching and Shoring.” Regardless of the soil type encountered in the excavation, shoring, trench boxes or sloped sidewalls will be required under Washington Industrial Safety and Health Act (WISHA). While this report describes certain approaches to excavation and dewatering, the contract documents should specify that the contractor is responsible for selecting excavation and dewatering methods, monitoring the excavations for safety and providing shoring, as required, to protect personnel and adjacent structures.

4.2.6. Weather Considerations

The native soils contain a sufficient percentage of fines (silt) to be moisture sensitive. When the moisture content of these soils is appreciably above the optimum moisture content, these soils become muddy and unstable, operation of equipment on these soils will be difficult, and it will be difficult if not impossible to meet the required compaction criteria. Disturbance of these near-surface soils should be expected if earthwork is completed during periods of wet weather.

The wet weather season generally begins in early November and continues through April in Western Washington; however, periods of wet weather may occur during any month of the year. The optimum earthwork period for these types of soils is typically June through October. If wet weather earthwork is unavoidable, we recommend that:

- Structural fill placed during the wet season or during periods of wet weather consist of gravel borrow (Section 9-03.14(1) of the 2021 Washington State Department of Transportation (WSDOT) Standard Specifications) with the added restriction that no more than 5 percent (of the material passing the U.S. No. 200 sieve). It may be desirable to place a geotextile over the native subgrades before placement of structural fill.
- The ground surface in and around the work areas be sloped so that surface water is directed away from the work areas. The ground surface should be graded such that areas of ponded water do not develop. Measures should be taken by the contractor to prevent surface water from collecting in excavations and trenches. Measures should be implemented to remove surface water from the work area.

4.2.7. Erosion and Sedimentation Control

The site will be susceptible to erosion during wet weather conditions, particularly if large segments of exposed subgrades are exposed to rainfall. Development, implementation and adherence to an Erosion and Sedimentation Control Plan should reduce the project impact on erosion-prone areas. The Plan should be designed in accordance with applicable county and/or state standards. The Plan should incorporate basic planning principles, including:

- Scheduling grading and construction to reduce soil exposure.
- Re-vegetating or mulching denuded areas.
- Directing runoff away from exposed soils.
- Reducing the length and steepness of slopes with exposed soils.
- Decreasing runoff velocities.
- Preparing drainage ways and outlets to handle concentrated or increased runoff.
- Confining sediment to the project site.
- Inspecting and maintaining control measures frequently.

Some sloughing erosion and raveling of exposed or disturbed soil on slopes should be expected, particularly if the work is completed during the wet season. We recommend that disturbed soil be restored promptly so that surface runoff does not become channeled.

Temporary erosion protection should be used and maintained in areas with exposed or disturbed soils to help reduce erosion and transport of sediment to adjacent areas and receiving waters. Permanent erosion protection should be provided by paving, structure construction or landscape planting.

Until the permanent erosion protection is established, and the site is stabilized, site monitoring may be required by qualified personnel who will evaluate the effectiveness of the erosion control measures and recommend repairs and/or modifications as appropriate. Provision for modifications to the erosion control system based on monitoring observations should be included in the Erosion and Sedimentation Control Plan.

4.3. Fill Materials

The workability of material used as structural fill depends on the gradation and moisture content of the soil. As the amount of fines (material passing the U.S. No. 200 sieve) increases, soil becomes increasingly sensitive to small changes in moisture content and adequate compaction becomes more difficult, if not impossible to achieve. As discussed previously, we recommend that select granular fill or crushed rock be used as structural fill during the rainy season. The following paragraphs summarize the material requirements for fill and backfill.

4.3.1. On-site Soils

The near-surface soils should not be considered for use as structural fill. The near-surface silty sand outwash soils are relatively thin. The glacial till soils will likely be above their optimum moisture content even during the normally dry summer months. We recommend that fill materials comprise either granular soils from the on-site gravel pit or an off-site source.

4.3.2. Borrow Pit Soils

Based on our previous work, we conclude that relatively clean sand and gravel soils from the on-site gravel pit can be considered for use as general purpose structural fill (utility backfill and drive areas).

4.3.3. Select Granular Fill

Select granular fill (pit run) must consist of imported well-graded sand, sandy gravel, or crushed rock with a maximum particle size of 3 inches and less than 5 percent passing a U.S. No. 200 sieve. Organic matter, debris, or other deleterious material must not be present. Granular fill used during periods of prolonged dry weather may have up to 12 percent passing a U.S. No. 200 sieve.

4.3.4. Crushed Rock Base Layer

As discussed in Section 4.6, base rock placed below the mat foundation should consist of either crushed surfacing base course, WSDOT 2021 Standard Specification 9-03.9(3) or coarse aggregate American Association of State Highway and Transportation Officials (AASHTO) Grading No. 67 (WSDOT 2021 Standard Specification 9-03.1(4)C).

4.3.5. Pipe Bedding

Trench backfill for the bedding and pipe zone should consist of well-graded granular material with a maximum particle size of $\frac{3}{4}$ inch and less than 5 percent passing the U.S. No. 200 sieve. The material must be free of roots, debris, organic matter, and other deleterious material.

4.4. Fill Placement and Compaction

4.4.1. General

Fill soils should be compacted at a moisture content near optimum. The maximum allowable moisture content varies with the soil gradation and should be evaluated during construction. Fill and backfill material should be placed in uniform, horizontal lifts, and uniformly densified with vibratory compaction equipment. Vibratory equipment should not be used if the subgrade material is wet.

The maximum lift thickness will vary depending on the material and compaction equipment used but should generally not exceed 10 inches in loose thickness. We recommend that density testing of the placed structural fill be completed by a qualified geotechnical engineer to check that the structural fill compaction requirements presented in this report are achieved.

4.4.2. Mat Foundation Base Rock

Base rock placed below the mat foundation should be placed in 6-inch or greater lift thickness and compacted to 95 percent of the maximum dry density (MDD) in accordance with ASTM D-1557.

4.4.3. Area Fills and Bases

Fill placed to raise site grades and aggregate base materials under parking/ driveway areas should be placed on a prepared subgrade that consists of firm, inorganic native soils or compacted fill. Fill must be compacted to at least 95 percent of the MDD determined by ASTM Test Method D 1557 (modified Proctor). In pavement areas, the compaction criteria can be reduced to 92 percent below a depth of 2 feet from finished grade.

During wet weather or in areas that are particularly sensitive to subgrade disturbance, we recommend placing a woven geotextile between the subgrade and the first lift of fill. For this application, the first lift must comprise select granular fill. We recommend a 10-inch lift thickness and densification by static rolling for the initial lift.

4.4.4. Trench Backfill

Backfill in the bedding and pipe zone should be compacted to 90 percent of the MDD as determined by ASTM Test Method D 1557, or as recommended by the pipe manufacturer.

In nonstructural areas, trench backfill above the pipe zone should be compacted to at least 85 percent of the MDD as determined by ASTM Test Method D 1557. Suitable native soils or select granular soils should be acceptable in non-structural areas.

Within structural areas, trench backfill placed above the pipe zone must be compacted to at least 92 percent of the MDD as determined by ASTM Test Method D 1557 at depths greater than 2 feet below the finished subgrade, and to 95 percent within 2 feet of finished subgrade. Trench backfill in structural areas should consist of select granular fill or crushed rock as described in the previous sections.

4.5. Temporary and Permanent Slopes

We recommend that permanent cut and fill slopes be inclined no steeper than 2H:1V (horizontal:vertical). Flatter cut slopes may be necessary in areas where persistent groundwater seepage or zones of soft or loose soils are encountered. Temporary cut slopes should be inclined no steeper than about 1½H:1V. Surface loads should be kept at a minimum distance of at least 5 feet or one-half the depth of the cut away from the top of the cut, whichever is greater.

As previously stated, temporary cut slopes and shoring must comply with the provisions of Title 296 WAC, Part N, "Excavation, Trenching and Shoring." The contractor performing the work must have the primary responsibility for protection of workmen and adjacent improvements, determining whether shoring is required, and for establishing the safe inclination for open-cut slopes.

To reduce the potential for erosion, newly constructed slopes should be planted or hydroseeded shortly after completion of grading. Some sloughing and raveling of the slopes should be expected until the vegetation is established. This may require localized repairs and reseeded. Temporary covering, such as heavy plastic sheeting, jute fabric, loose straw, or excelsior matting should be used to protect unvegetated slopes during periods of rainfall.

4.6. Tank Mat Foundation

The proposed tank may be satisfactorily supported on a mat foundation supported on the medium dense to dense native soils or on crushed rock overlying these soils (anticipated to be encountered below a depth of 2 feet). A minimum 6-inch base rock layer should underlie the mat slab for uniform support as discussed below. An allowable soil bearing pressure of 4,000 psf can be used in design for the mat supported as recommended. The contact depth of the supporting layer is interpreted from subsurface information obtained in our test pits. GeoEngineers should observe subgrade preparation to confirm that actual field conditions are consistent with our design recommendations.

We recommend a minimum 6-inch-thick layer of crushed rock be placed beneath the proposed mat foundation to provide a level foundation pad and prevent disturbance. A thicker layer will be appropriate to protect the subgrade if the subgrade becomes wet, to provide a level pad if considerable boulders are encountered and require removal, or to extend to the depth of medium dense to dense native soils. The subgrade should be clean and free of loose soil prior to placing the base rock.

4.7. Subgrade Modulus

The modulus of subgrade reaction required to analyze a mat foundation will depend on a number of factors, including subsurface soils, the shape and rigidity of the mat foundation, the depth of the mat foundation below adjacent grade and loading configuration on the mat. We estimate that a modulus of subgrade reaction of about 125 pounds per cubic inch (pci) would be appropriate for evaluating a mat foundation, provided it is founded as recommended in this report.

4.8. Lateral Resistance

Lateral loads may be resisted by passive pressure on the sides of below-grade elements and as friction on the base of the foundation.

An allowable passive resistance on the face of embedded foundation elements may be computed using an equivalent fluid density of 250 pcf for on-site medium dense native soils anticipated below a depth of 2 feet. This value can be increased to 350 pcf for the dense native soils encountered below a depth of 3 feet. The allowable frictional resistance may be computed using a coefficient of friction of 0.4 applied to vertical dead-load forces. The above passive equivalent fluid density values and coefficient of friction include a factor of safety of about 1.5.

Seismic Design Parameters

We recommend the use of the following 2018 IBC parameters for seismic design:

TABLE 1. SEISMIC DESIGN PARAMETERS

2018 IBC (ASCE 7-16) Seismic Design Parameters	
Spectral Response Acceleration at Short Periods (S_s)	1.188g
Spectral Response Acceleration at 1-Second Periods (S_1)	0.424g
Site Class	D
Design Peak Ground Acceleration (PGA_M)	0.55g
Design Spectral Response Acceleration at Short Periods (S_{DS})	0.812g
Design Spectral Response Acceleration at 1-Second Periods (S_{D1})	null ¹

¹ A ground motion hazard analysis may be required in accordance with Section 11.4.8 of American Society of Civil Engineers (ASCE) 7-16 unless Exception 2 is utilized in design.

4.8.1. Liquefaction Potential

Liquefaction refers to a condition where vibration or shaking of the ground, usually from earthquake forces, results in development of excess pore pressures in loose, saturated soils and subsequent loss of strength in the deposit of soil so affected. In general, soils that are susceptible to liquefaction include loose to medium dense “clean” to silty sands that are below the water table. Based on the conditions in our explorations, there is the potential for some of the sand ice contact/outwash soils to experience liquefaction. However, based on the consistency of the glacial soils and Mashel Formation, and depth to groundwater, it is our opinion the risk of liquefaction is low at the site.

5.0 LIMITATIONS

We have prepared this report for use by Robert W. Droll Landscape Architects and other members of the design and construction team for the proposed Water Tank at the Nisqually State Park site.

Within the limitations of scope, schedule and budget, our services have been executed in accordance with generally accepted engineering practices in this area at the time this report was prepared. No warranty or other conditions express or implied should be understood.

Please refer to Appendix B titled “Report Limitations and Guidelines for Use” for additional information pertaining to use of this report.



P:\2\2935067\GIS\2935067_Project.aprx\293506701_F01_VicinityMap_WW_WaterTank Date Exported: 05/24/22 by glohnmeyer

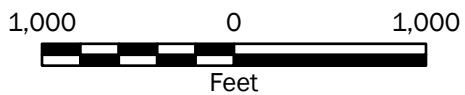

Vicinity Map

Nisqually State Park Proposed Water Tank
Pierce County, Washington



Figure 1

Notes:

1. The locations of all features shown are approximate.
2. This drawing is for information purposes. It is intended to assist in showing features discussed in an attached document. GeoEngineers, Inc. cannot guarantee the accuracy and content of electronic files. The master file is stored by GeoEngineers, Inc. and will serve as the official record of this communication.

Data Source: ESRI
Projection: NAD 1983 UTM Zone 10N

P:\2935067\CAD\01\Geotech Report - Maint Building\WWTP and Water Tank Sites_293506701_F02_Site Plan.dwg TAB:F02 Date Exported: 05/26/22 - 8:39 by syj

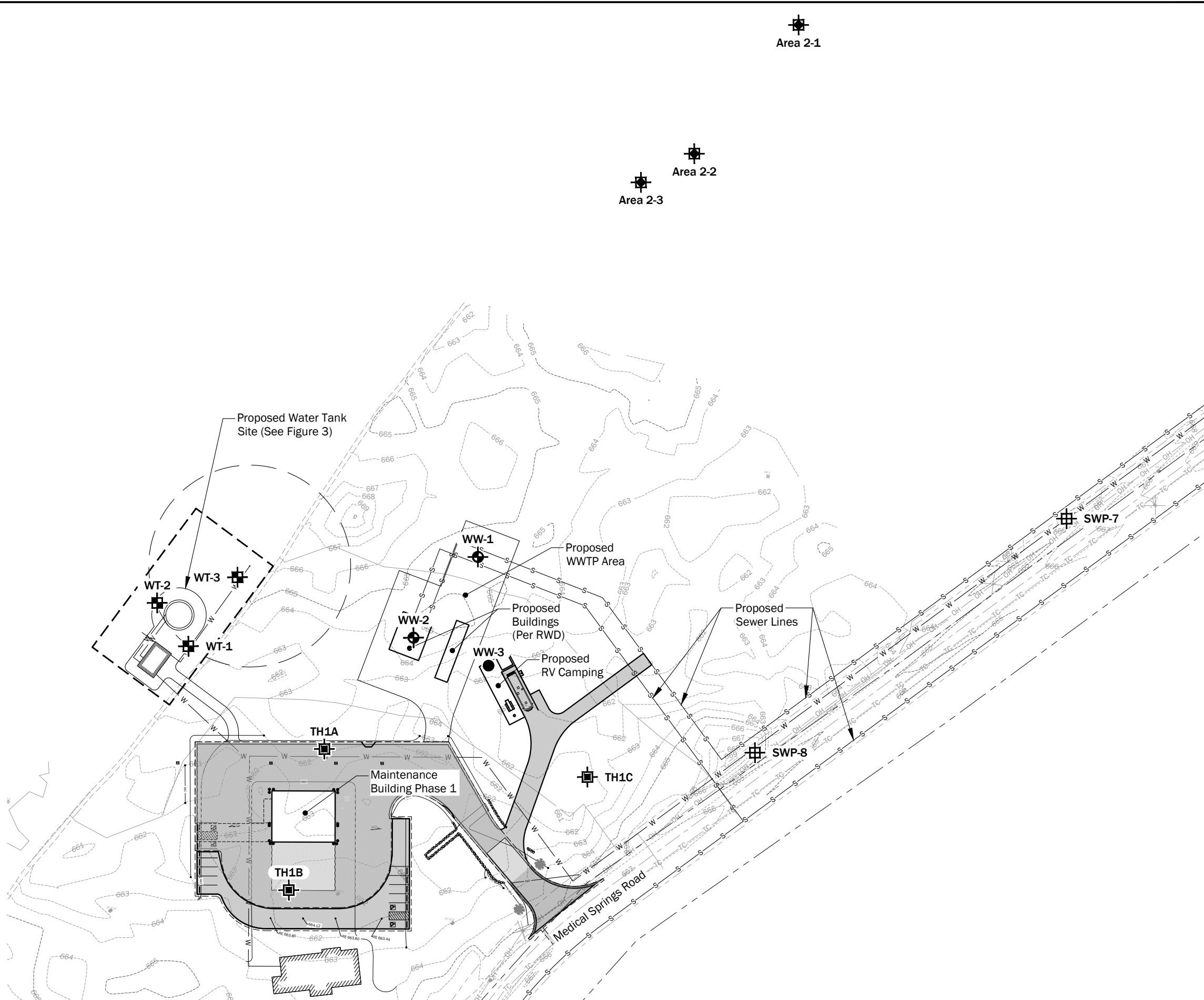

- Legend**
- WT-1 [Symbol] Test Pit by GeoEngineers, Inc., 2022
 - WW-1 [Symbol] Boring by GeoEngineers, Inc., 2021
 - WW-3 [Symbol] Monitoring Well by GeoEngineers, Inc., 2021
 - SWP-8 [Symbol] Test Pit by GeoEngineers, Inc., 2021
 - Area 2-3 [Symbol] Test Pit by GeoEngineers, Inc. for Proposed Drainage Basin 2, 2021
 - TH1A [Symbol] Test Pit by GeoEngineers, Inc. for Proposed Maintenance Building Area, 2020

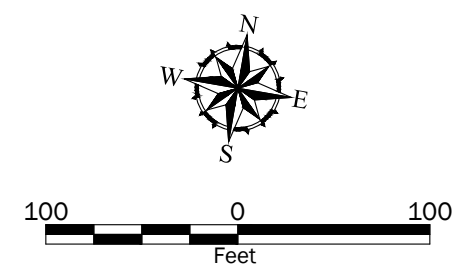

- Notes:**
1. The locations of all features shown are approximate.
 2. This drawing is for information purposes. It is intended to assist in showing features discussed in an attached document. GeoEngineers, Inc. cannot guarantee the accuracy and content of electronic files. The master file is stored by GeoEngineers, Inc. and will serve as the official record of this communication.

Data Source: Background from RWD Landscape Architects, dated 09/07/21.

Vertical Datum: NAVD 88.

Projection: NAD83 Washington State Planes, South Zone, US Foot.

Site Plan	
Nisqually State Park, Maintenance Building, WWTP and Water Tank Sites Pierce County, Washington	
	Figure 2

P:\2935067\GIS\2935067_GIS\2935067_F03_SitePlan_WW_WaterTank Date Exported: 05/25/22 by glahrmeier

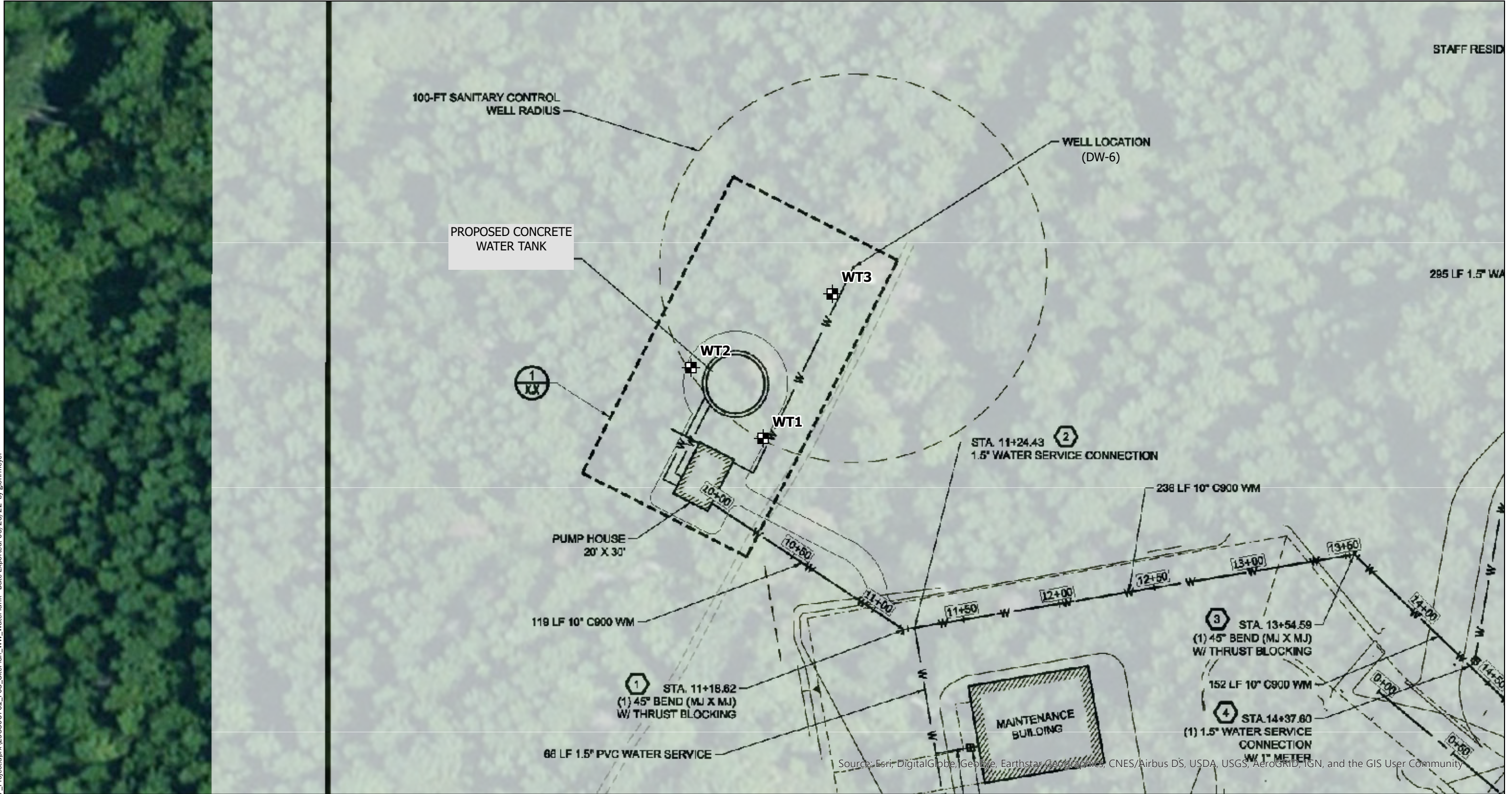

Notes:
 1. The locations of all features shown are approximate.
 2. This drawing is for information purposes. It is intended to assist in showing features discussed in an attached document. GeoEngineers, Inc. cannot guarantee the accuracy and content of electronic files. The master file is stored by GeoEngineers, Inc. and will serve as the official record of this communication.
 Data Source: Basemap from WA State Parks and Recreation Commission, Aerial from ESRI.

Legend
 WT-1 [Symbol] Test Pit by GeoEngineers, Inc., 2022

Projection: NAD 1983 StatePlane Washington South FIPS 4602 Feet

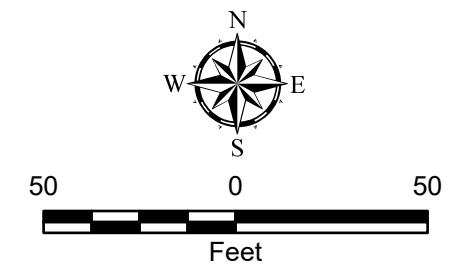

Site Plan	
Nisqually State Park Proposed Water Tank Pierce County, Washington	
	Figure 3

SOIL CLASSIFICATION CHART

MAJOR DIVISIONS			SYMBOLS		TYPICAL DESCRIPTIONS
			GRAPH	LETTER	
COARSE GRAINED SOILS	GRAVEL AND GRAVELLY SOILS	CLEAN GRAVELS <small>(LITTLE OR NO FINES)</small>		GW	WELL-GRADED GRAVELS, GRAVEL - SAND MIXTURES
		GRAVELS WITH FINES <small>(APPRECIABLE AMOUNT OF FINES)</small>		GP	POORLY-GRADED GRAVELS, GRAVEL - SAND MIXTURES
		GRAVELS WITH FINES <small>(APPRECIABLE AMOUNT OF FINES)</small>		GM	SILTY GRAVELS, GRAVEL - SAND - SILT MIXTURES
	SAND AND SANDY SOILS	CLEAN SANDS <small>(LITTLE OR NO FINES)</small>		SW	WELL-GRADED SANDS, GRAVELLY SANDS
		SANDS WITH FINES <small>(APPRECIABLE AMOUNT OF FINES)</small>		SP	POORLY-GRADED SANDS, GRAVELLY SAND
		SANDS WITH FINES <small>(APPRECIABLE AMOUNT OF FINES)</small>		SM	SILTY SANDS, SAND - SILT MIXTURES
FINE GRAINED SOILS	SILTS AND CLAYS	LIQUID LIMIT LESS THAN 50		ML	INORGANIC SILTS, ROCK FLOUR, CLAYEY SILTS WITH SLIGHT PLASTICITY
		LIQUID LIMIT LESS THAN 50		CL	INORGANIC CLAYS OF LOW TO MEDIUM PLASTICITY, GRAVELLY CLAYS, SANDY CLAYS, SILTY CLAYS, LEAN CLAYS
		LIQUID LIMIT LESS THAN 50		OL	ORGANIC SILTS AND ORGANIC SILTY CLAYS OF LOW PLASTICITY
	SILTS AND CLAYS	LIQUID LIMIT GREATER THAN 50		MH	INORGANIC SILTS, MICACEOUS OR DIATOMACEOUS SILTY SOILS
		LIQUID LIMIT GREATER THAN 50		CH	INORGANIC CLAYS OF HIGH PLASTICITY
		LIQUID LIMIT GREATER THAN 50		OH	ORGANIC CLAYS AND SILTS OF MEDIUM TO HIGH PLASTICITY
HIGHLY ORGANIC SOILS			PT	PEAT, HUMUS, SWAMP SOILS WITH HIGH ORGANIC CONTENTS	

NOTE: Multiple symbols are used to indicate borderline or dual soil classifications

Sampler Symbol Descriptions

	2.4-inch I.D. split barrel / Dames & Moore (D&M)
	Standard Penetration Test (SPT)
	Shelby tube
	Piston
	Direct-Push
	Bulk or grab
	Continuous Coring

Blowcount is recorded for driven samplers as the number of blows required to advance sampler 12 inches (or distance noted). See exploration log for hammer weight and drop.

"P" indicates sampler pushed using the weight of the drill rig.

"WOH" indicates sampler pushed using the weight of the hammer.

NOTE: The reader must refer to the discussion in the report text and the logs of explorations for a proper understanding of subsurface conditions. Descriptions on the logs apply only at the specific exploration locations and at the time the explorations were made; they are not warranted to be representative of subsurface conditions at other locations or times.

ADDITIONAL MATERIAL SYMBOLS

SYMBOLS		TYPICAL DESCRIPTIONS
GRAPH	LETTER	
	AC	Asphalt Concrete
	CC	Cement Concrete
	CR	Crushed Rock/ Quarry Spalls
	SOD	Sod/Forest Duff
	TS	Topsoil

Groundwater Contact



Measured groundwater level in exploration, well, or piezometer



Measured free product in well or piezometer

Graphic Log Contact

Distinct contact between soil strata

Approximate contact between soil strata

Material Description Contact

Contact between geologic units

Contact between soil of the same geologic unit

Laboratory / Field Tests

%F	Percent fines
%G	Percent gravel
AL	Atterberg limits
CA	Chemical analysis
CP	Laboratory compaction test
CS	Consolidation test
DD	Dry density
DS	Direct shear
HA	Hydrometer analysis
MC	Moisture content
MD	Moisture content and dry density
Mohs	Mohs hardness scale
OC	Organic content
PM	Permeability or hydraulic conductivity
PI	Plasticity index
PL	Point lead test
PP	Pocket penetrometer
SA	Sieve analysis
TX	Triaxial compression
UC	Unconfined compression
UU	Unconsolidated undrained triaxial compression
VS	Vane shear

Sheen Classification

NS	No Visible Sheen
SS	Slight Sheen
MS	Moderate Sheen
HS	Heavy Sheen

Key to Exploration Logs

Date Excavated	3/24/2022	Total Depth (ft)	6	Logged By	OA	Excavator	Volvo ECR 88D	Groundwater not observed
		Checked By	SWH	Equipment	Volvo ECR 88D			Caving not observed
Surface Elevation (ft)	Undetermined		Latitude			Coordinate System	WA State Plane South	
Vertical Datum	NAVD88		Longitude			Horizontal Datum	NAD83 (feet)	

Elevation (feet)	Depth (feet)	SAMPLE		Group Classification	MATERIAL DESCRIPTION	Moisture Content (%)	Fines Content (%)	REMARKS
		Testing Sample	Sample Name Testing					
				Duff	Forest duff surfaced with ferns, boulders up to 1½ feet (b-axis)			Roots extend to approximately 3½ feet bgs
	1	1		SM	Dark brown silty sand with gravel, occasional organic matter (wood debris, burnt sticks) (loose, moist) (outwash)	24	32	
	2			GM	Light gray silty gravel with sand and occasional boulders up to 1½ feet diameter (medium dense to very dense, moist) (glacial till? or drift?)			
	3	2						
	4	3			Grades to gray and very dense	10	42	
	5							
	6				Terminated at 6 feet due to practical refusal			

Notes: See Figure A-1 for explanation of symbols.
The depths on the test pit logs are based on an average of measurements across the test pit and should be considered accurate to ½ foot.
Coordinates Data Source: Horizontal approximated based on Topographic Survey. Vertical approximated based on Topographic Survey.

Log of Test Pit WT-1



Project: Nisqually State Park, Proposed Water Tank
Project Location: Pierce County, Washington
Project Number: 2935-067-01

Date: 6/10/22 Path: \\GEOENGINEERS.COM\WORK\PROJECTS\2935067\GINT\2935067\GIB\GERB_TESTPIT_1P_GEOtec_MF

Date Excavated	3/24/2022	Total Depth (ft)	4.75	Logged By	OA	Excavator	Volvo ECR 88D	See "Remarks" section for groundwater observed
Checked By	SWH	Equipment						Caving not observed
Surface Elevation (ft)	Undetermined	Latitude		Coordinate System	WA State Plane South			
Vertical Datum	NAVD88	Longitude		Horizontal Datum	NAD83 (feet)			

Elevation (feet)	Depth (feet)	SAMPLE		Group Classification	MATERIAL DESCRIPTION	Moisture Content (%)	Fines Content (%)	REMARKS
		Testing Sample	Sample Name Testing					
				Duff	Forest duff surfaced with ferns, boulders up to 1 foot diameter			
	1	1		SM	Light brown silty fine to coarse sand with gravel (medium dense, moist) (outwash)			
	2			GM	Light brown silty gravel with sand (medium dense, moist) (weathered till?)			
	3	2		GM	Gray and orange with moderate to heavy oxidation staining silty gravel with sand (dense, moist) (till)			
	4	3			Grades to very dense, weathered bedrock?			Slow groundwater seepage observed at 4 feet
Terminated at 4¾ feet due to practical refusal								

Notes: See Figure A-1 for explanation of symbols.
The depths on the test pit logs are based on an average of measurements across the test pit and should be considered accurate to ½ foot.
Coordinates Data Source: Horizontal approximated based on Topographic Survey. Vertical approximated based on Topographic Survey.

Log of Test Pit WT-2



Project: Nisqually State Park, Proposed Water Tank
Project Location: Pierce County, Washington
Project Number: 2935-067-01

Date: 6/10/22 Path: \\GEOENGINEERS.COM\WORK\PROJECTS\2935067\GINT\2935067\GIB\GIB_2017\GIB\GERB_TESTPIT_1P_GEOTEC_MF

Date Excavated	3/24/2022	Total Depth (ft)	4.25	Logged By	OA	Excavator	Volvo ECR 88D	Groundwater not observed
		Checked By	SWH	Equipment	Volvo ECR 88D			Caving not observed
Surface Elevation (ft)	Undetermined		Latitude	Longitude		Coordinate System	WA State Plane South	
Vertical Datum	NAVD88				Horizontal Datum	NAD83 (feet)		

Elevation (feet)	Depth (feet)	SAMPLE		Group Classification	MATERIAL DESCRIPTION	Moisture Content (%)	Fines Content (%)	REMARKS
		Testing Sample	Sample Name Testing					
				Duff	Approximately 6 inches of forest duff surfaced with ferns, boulders up to 1 foot diameter			
	1			SM	Dark brown silty fine to coarse sand with gravel (loose to medium dense, moist) (outwash)			
	2	1		GM	Light brown silty gravel with sand (medium dense, moist) (weathered till)	16	45	
	3			GM	Gray and orange with moderate to heavy oxidation staining silty gravel with sand (dense, moist) (till)			
	4	2			Grades to without oxidation staining			
		3						
Terminated at 4½ feet due to practical refusal								

Notes: See Figure A-1 for explanation of symbols.
The depths on the test pit logs are based on an average of measurements across the test pit and should be considered accurate to ½ foot.
Coordinates Data Source: Horizontal approximated based on Topographic Survey. Vertical approximated based on Topographic Survey.

Log of Test Pit WT-3



Project: Nisqually State Park, Proposed Water Tank
Project Location: Pierce County, Washington
Project Number: 2935-067-01

Date: 6/10/22 Path: \\GEOENGINEERS.COM\WORK\PROJECTS\2935067\GINT\2935067\GIB\Library\Library\GEOENGINEERS_DF_STD_US_JUNE_2017\GIB\GERB_TESTPIT_IP_GEOTEC_MF

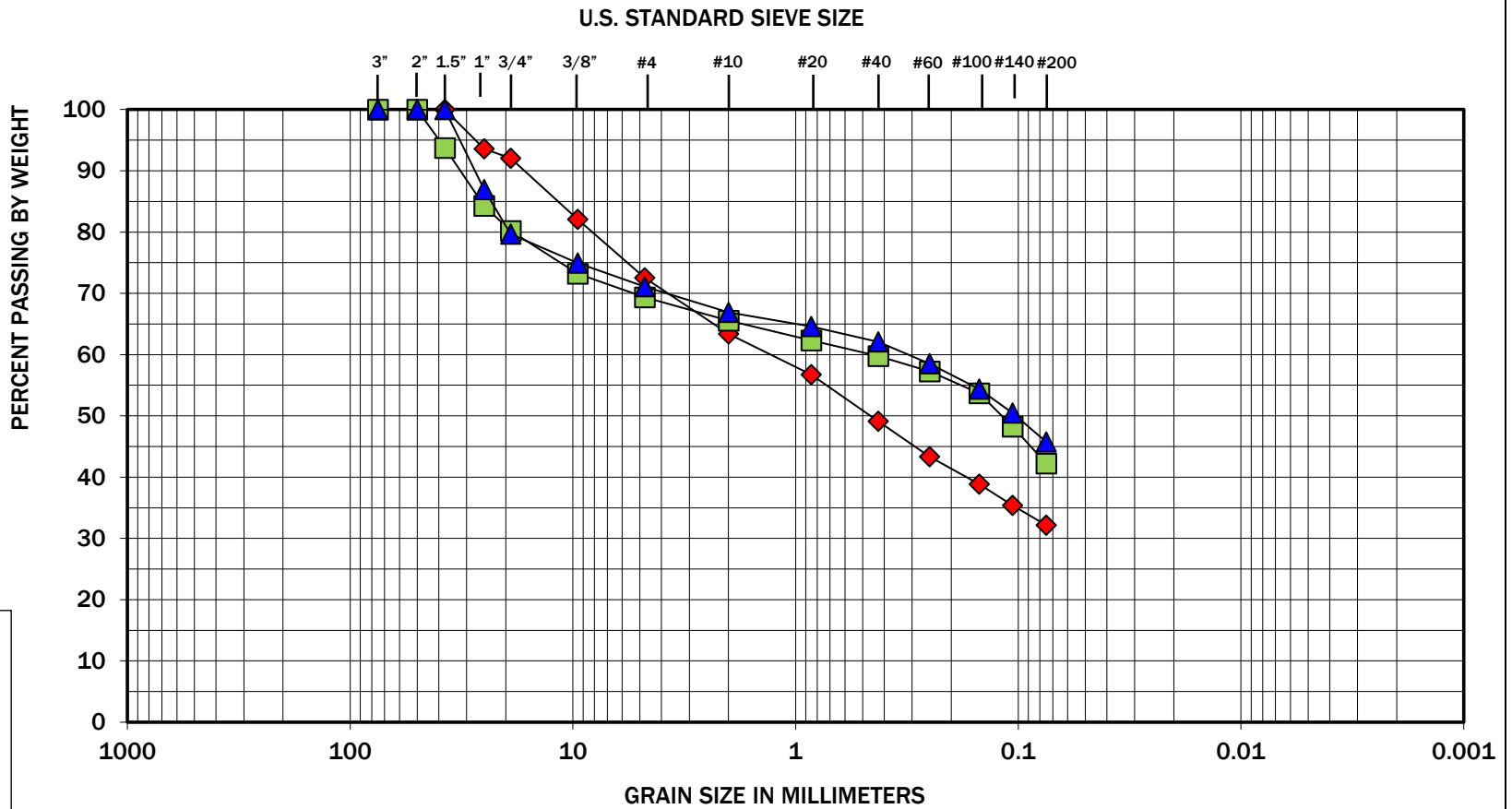

APPENDIX A
Logs of Explorations

SOIL CLASSIFICATION CHART

MAJOR DIVISIONS			SYMBOLS		TYPICAL DESCRIPTIONS
			GRAPH	LETTER	
COARSE GRAINED SOILS	GRAVEL AND GRAVELLY SOILS	CLEAN GRAVELS <small>(LITTLE OR NO FINES)</small>		GW	WELL-GRADED GRAVELS, GRAVEL - SAND MIXTURES
		GRAVELS WITH FINES <small>(APPRECIABLE AMOUNT OF FINES)</small>		GP	POORLY-GRADED GRAVELS, GRAVEL - SAND MIXTURES
		GRAVELS WITH FINES <small>(APPRECIABLE AMOUNT OF FINES)</small>		GM	SILTY GRAVELS, GRAVEL - SAND - SILT MIXTURES
	SAND AND SANDY SOILS	CLEAN SANDS <small>(LITTLE OR NO FINES)</small>		SW	WELL-GRADED SANDS, GRAVELLY SANDS
		SANDS WITH FINES <small>(APPRECIABLE AMOUNT OF FINES)</small>		SP	POORLY-GRADED SANDS, GRAVELLY SAND
		SANDS WITH FINES <small>(APPRECIABLE AMOUNT OF FINES)</small>		SM	SILTY SANDS, SAND - SILT MIXTURES
FINE GRAINED SOILS	SILTS AND CLAYS	LIQUID LIMIT LESS THAN 50		ML	INORGANIC SILTS, ROCK FLOUR, CLAYEY SILTS WITH SLIGHT PLASTICITY
		LIQUID LIMIT LESS THAN 50		CL	INORGANIC CLAYS OF LOW TO MEDIUM PLASTICITY, GRAVELLY CLAYS, SANDY CLAYS, SILTY CLAYS, LEAN CLAYS
		LIQUID LIMIT LESS THAN 50		OL	ORGANIC SILTS AND ORGANIC SILTY CLAYS OF LOW PLASTICITY
	SILTS AND CLAYS	LIQUID LIMIT GREATER THAN 50		MH	INORGANIC SILTS, MICACEOUS OR DIATOMACEOUS SILTY SOILS
		LIQUID LIMIT GREATER THAN 50		CH	INORGANIC CLAYS OF HIGH PLASTICITY
		LIQUID LIMIT GREATER THAN 50		OH	ORGANIC CLAYS AND SILTS OF MEDIUM TO HIGH PLASTICITY
HIGHLY ORGANIC SOILS			PT	PEAT, HUMUS, SWAMP SOILS WITH HIGH ORGANIC CONTENTS	

NOTE: Multiple symbols are used to indicate borderline or dual soil classifications

Sampler Symbol Descriptions

	2.4-inch I.D. split barrel
	Standard Penetration Test (SPT)
	Shelby tube
	Piston
	Direct-Push
	Bulk or grab
	Continuous Coring

Blowcount is recorded for driven samplers as the number of blows required to advance sampler 12 inches (or distance noted). See exploration log for hammer weight and drop.

"P" indicates sampler pushed using the weight of the drill rig.

"WOH" indicates sampler pushed using the weight of the hammer.

NOTE: The reader must refer to the discussion in the report text and the logs of explorations for a proper understanding of subsurface conditions. Descriptions on the logs apply only at the specific exploration locations and at the time the explorations were made; they are not warranted to be representative of subsurface conditions at other locations or times.

ADDITIONAL MATERIAL SYMBOLS

SYMBOLS		TYPICAL DESCRIPTIONS
GRAPH	LETTER	
	AC	Asphalt Concrete
	CC	Cement Concrete
	CR	Crushed Rock/Quarry Spalls
	SOD	Sod/Forest Duff
	TS	Topsoil

Groundwater Contact



Measured groundwater level in exploration, well, or piezometer



Measured free product in well or piezometer

Graphic Log Contact

Distinct contact between soil strata

Approximate contact between soil strata

Material Description Contact

Contact between geologic units

Contact between soil of the same geologic unit

Laboratory / Field Tests

%F	Percent fines
%G	Percent gravel
AL	Atterberg limits
CA	Chemical analysis
CP	Laboratory compaction test
CS	Consolidation test
DD	Dry density
DS	Direct shear
HA	Hydrometer analysis
MC	Moisture content
MD	Moisture content and dry density
Mohs	Mohs hardness scale
OC	Organic content
PM	Permeability or hydraulic conductivity
PI	Plasticity index
PL	Point load test
PP	Pocket penetrometer
SA	Sieve analysis
TX	Triaxial compression
UC	Unconfined compression
VS	Vane shear

Sheen Classification

NS	No Visible Sheen
SS	Slight Sheen
MS	Moderate Sheen
HS	Heavy Sheen

Key to Exploration Logs



Figure A-1

Date Excavated	1/20/2021	Total Depth (ft)	9.5	Logged By	CJL	Excavator	Kelly's Excavating	See "Remarks" section for groundwater observed See "Remarks" section for caving observed
				Checked By	SWH	Equipment	Komatsu PC120	
Surface Elevation (ft) Vertical Datum	Undetermined NAVD88		Easting (X) Northing (Y)	Coordinate System Horizontal Datum		WA State Plane South NAD83 (feet)		

Elevation (feet)	Depth (feet)	SAMPLE		Graphic Log	Group Classification	MATERIAL DESCRIPTION	Moisture Content (%)	Fines Content (%)	REMARKS
		Testing Sample	Sample Name Testing						
					DUFF	Approximately 6 inches of forest duff			
	1				SM	Brown-gray silty fine sand with occasional 1/4- to 1/2-inch roots (loose, moist)			
	2				SP-SM	Brown-gray fine sand with silt (loose, moist)			
	3		1 SA		SM	Brown-gray silty fine sand with trace 1/2-inch roots (loose, moist)	29	40	Significant caving observed from 3 to 6 feet
	4				SP-SM	Brown-gray fine to coarse sand with silt and gravel (loose, moist)			
	5				SP	Gray fine to medium sand with gravel and trace silt (medium dense, moist)			
	6		2 S		SP	Gray fine to medium sand with gravel and trace silt (medium dense, moist)	6	2	
	7				GP	Gray fine to coarse gravel with sand, cobbles and trace silt (dense, wet)			
	9		3		GP	Gray fine to coarse gravel with sand, cobbles and trace silt (dense, wet)			Rapid groundwater seepage observed at 9 1/2 feet

Notes: See Figure A-1 for explanation of symbols.
The depths on the test pit logs are based on an average of measurements across the test pit and should be considered accurate to 1/2 foot.
Coordinates Data Source: Horizontal approximated based on . Vertical approximated based on .

Log of Test Pit TH-4A



Project: Proposed Maintenance Facility Nisqually State Park
Project Location: Pierce County, Washington
Project Number: 2935-067-00

Date: 2/16/21 Path: P:\2935\067\GINT\293506700.GPJ DBLibrary\Library\GEOENGINEERS_DF_STD_US_JUNE_2017\GLB\GEI6_TESTPIT_IP_GEOTEC_%F

Date Excavated	1/20/2021	Total Depth (ft)	8	Logged By	CJL	Excavator	Kelly's Excavating	See "Remarks" section for groundwater observed	
				Checked By	SWH	Equipment	Komatsu PC120	See "Remarks" section for caving observed	
Surface Elevation (ft)		Undetermined		Easting (X)		Coordinate System		WA State Plane South	
Vertical Datum		NAVD88		Northing (Y)		Horizontal Datum		NAD83 (feet)	

Elevation (feet)	Depth (feet)	SAMPLE		Graphic Log	Group Classification	MATERIAL DESCRIPTION	Moisture Content (%)	Fines Content (%)	REMARKS
		Testing Sample	Sample Name Testing						
					SOD	Approximately 4 inches of sod			
	1				GM	Dark brown silty fine to coarse gravel with sand, cobbles and boulders (dense, moist) (outwash)			Moderate caving observed from 1 to 3 feet
	2				GP-GM	Brown fine to coarse gravel with silt, sand, cobbles and boulders (dense, moist) (till?)			
	3				GP	Grades to wet	9	8	Heavy perched groundwater seepage observed at 2 3/4 feet
	4				GP	Brown fine to coarse gravel with sand, cobbles, boulders and trace silt (dense, wet) (outwash?)			
	5				ML	Gray with iron oxide staining silt with fine sand and trace gravel (hard, moist) (glaciolacustrine)			
	6								
	7								
	8								

Notes: See Figure A-1 for explanation of symbols.
The depths on the test pit logs are based on an average of measurements across the test pit and should be considered accurate to 1/2 foot.
Coordinates Data Source: Horizontal approximated based on . Vertical approximated based on .

Log of Test Pit TH-4B



Project: Proposed Maintenance Facility Nisqually State Park
Project Location: Pierce County, Washington
Project Number: 2935-067-00

Figure A-3
Sheet 1 of 1

Date: 2/16/21 Path: P:\2935\067\GINT\293506700.GPJ DBLibrary\Library\GEOENGINEERS_DF_STD_US_JUNE_2017\GLB\GEI6_TESTPIT_IP_GEOTEC_%F

Date Excavated	1/20/2021	Total Depth (ft)	14	Logged By	CJL	Excavator	Kelly's Excavating	Groundwater not observed
				Checked By	SWH	Equipment	Komatsu PC120	See "Remarks" section for caving observed
Surface Elevation (ft) Vertical Datum	Undetermined NAVD88		Easting (X) Northing (Y)	Coordinate System Horizontal Datum		WA State Plane South NAD83 (feet)		

Elevation (feet)	Depth (feet)	SAMPLE		Graphic Log	Group Classification	MATERIAL DESCRIPTION	Moisture Content (%)	Fines Content (%)	REMARKS
		Testing Sample	Sample Name Testing						
					DUF	Approximately 6 inches of forest duff			
	1				GP	Brown-gray fine to coarse gravel with sand, cobbles and trace silt (dense, moist) (fill)			
	2				SP	Brown-gray fine sand with trace silt and occasional gravel (loose, moist) (fill)			
	3	1				Grades to medium dense with occasional cobbles			
	6	2			GP-GM	Brown-gray fine to coarse gravel with sand, silt, cobbles, occasional boulders (dense, _____) (outwash/alluvium)			Increased gravel
	11				GP-GM	Brown-gray fine gravel with sand, silt, gravel and occasional cobbles (dense, moist) (outwash/alluvium)			
	12	3				Grades to with fine roots at 12 to 12½ feet			Minor caving observed from 12 to 13 feet
	14				GP	Brown-gray fine to coarse gravel with sand, cobbles and trace silt (very dense, moist) (outwash/alluvium)			

Notes: See Figure A-1 for explanation of symbols.
The depths on the test pit logs are based on an average of measurements across the test pit and should be considered accurate to ½ foot.
Coordinates Data Source: Horizontal approximated based on . Vertical approximated based on .

Log of Test Pit TB-4A









Project: Proposed Maintenance Facility Nisqually State Park
Project Location: Pierce County, Washington
Project Number: 2935-067-00

Figure A-4
Sheet 1 of 1

Date: 2/16/21 Path: P:\2935\067\GINT\2935\067\00.GPJ DBLibrary\Library\GEOENGINEERS_DF_STD_US_JUNE_2017\GLB\GEI6_TESTPIT_IP_GEOTEC_%F

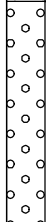
Date Excavated	1/20/2021	Total Depth (ft)	11.5	Logged By	CJL	Excavator	Kelly's Excavating	See "Remarks" section for groundwater observed See "Remarks" section for caving observed
				Checked By	SWH	Equipment	Komatsu PC120	
Surface Elevation (ft) Vertical Datum	Undetermined NAVD88		Easting (X) Northing (Y)	Coordinate System Horizontal Datum		WA State Plane South NAD83 (feet)		

Elevation (feet)	Depth (feet)	SAMPLE		Graphic Log	Group Classification	MATERIAL DESCRIPTION	Moisture Content (%)	Fines Content (%)	REMARKS
		Testing Sample	Sample Name Testing						
					DUFF	Approximately 8 inches of forest duff			Moderate caving observed from 0 to 5 feet
	1				SP	Brown-gray fine to medium sand with occasional 1/4- to 1-inch roots and trace silt (loose, moist) (outwash)			
	2		1			Grades to medium dense with occasional gravel			Occasional approximate 3- to 6-inch lenses of fine sand
	3								
	4								
	5					Grades to gray with trace gravel			
	6		2 MC				5		
	7								Significant caving observed from 7 to 11 1/2 feet
	8								
	9				GP	Brown-gray fine to coarse gravel with sand, cobbles, occasional boulders and trace silt (very dense, moist)			
	10		3			Grades to wet			
	11								Heavy groundwater seepage observed at 11 feet

Notes: See Figure A-1 for explanation of symbols.
The depths on the test pit logs are based on an average of measurements across the test pit and should be considered accurate to 1/2 foot.
Coordinates Data Source: Horizontal approximated based on . Vertical approximated based on .

Log of Test Pit TB-4B



Project: Proposed Maintenance Facility Nisqually State Park
Project Location: Pierce County, Washington
Project Number: 2935-067-00

Figure A-5
Sheet 1 of 1

Date: 2/16/21 Path: P:\2935\067\GINT\293506700.GPJ DBLibrary\Library\GEOENGINEERS_DF_STD_US_JUNE_2017\GLB\GEI6_TESTPIT_IP_GEOTECH.F

Date Excavated	1/20/2021	Total Depth (ft)	9.5	Logged By	CJL	Excavator	Kelly's Excavating	See "Remarks" section for groundwater observed See "Remarks" section for caving observed
				Checked By	SWH	Equipment	Komatsu PC120	
Surface Elevation (ft) Vertical Datum	Undetermined NAVD88		Easting (X) Northing (Y)	Coordinate System Horizontal Datum		WA State Plane South NAD83 (feet)		

Elevation (feet)	Depth (feet)	SAMPLE		Graphic Log	Group Classification	MATERIAL DESCRIPTION	Moisture Content (%)	Fines Content (%)	REMARKS
		Testing Sample	Sample Name Testing						
					SOD	Approximately 3 inches of sod			Old campfire
					SP-SM	Brown fine to medium sand with silt and deleterious debris (charcoal, glass and plastic) (loose, moist) (fill)			
	1				GP	Brown-gray fine to coarse gravel with sand, cobbles, occasional boulders, trace silt and occasional 1/4- to 1-inch roots (medium dense, moist) (alluvium)			Moderate caving observed from 3 to 6 feet
	2								
	3								
	4		g1-4				3	1	Significant caving observed from 7 to 9 1/2 feet
	5								
	6								
	7								
	8								Heavy groundwater observed at 9 1/4 feet
	9		g1-2			Grades to wet	6	1	

Notes: See Figure A-1 for explanation of symbols.
The depths on the test pit logs are based on an average of measurements across the test pit and should be considered accurate to 1/2 foot.
Coordinates Data Source: Horizontal approximated based on . Vertical approximated based on .

Log of Test Pit TB-4C



Project: Proposed Maintenance Facility Nisqually State Park
Project Location: Pierce County, Washington
Project Number: 2935-067-00

Figure A-6
Sheet 1 of 1

Date: 2/16/21 Path: P:\2935\067\GINT\293506700.GPJ DBLibrary\Library\GEOENGINEERS_DF_STD_US_JUNE_2017\GLB\GEIB_TESTPIT_IP_GEOTEC_%F

WATER WELL REPORT



DEPARTMENT OF
ECOLOGY
State of Washington

Type of Work:

Construction
 Decommission \Rightarrow Original installation NOI No. _____

Proposed Use: Domestic Industrial Municipal
 Dewatering Irrigation Test Well Other _____

Construction Type: New well Alteration Deepening Other _____
Method: Driven Jetted Cable Tool Dug Air- Mud-Rotary

Dimensions: Diameter of boring 8 in., to 275 ft.
Depth of completed well 285 ft.

Construction Details:		Wall							
Casing	Liner	Diameter	From	To	Thickness	Steel	PVC	Welded	Thread
<input checked="" type="checkbox"/>	<input type="checkbox"/>	8 in.	0	255	.375 in.	<input checked="" type="checkbox"/>	<input type="checkbox"/>	<input checked="" type="checkbox"/>	<input type="checkbox"/>
<input type="checkbox"/>	<input checked="" type="checkbox"/>	7.5 in.	252	285	.375 in.	<input checked="" type="checkbox"/>	<input type="checkbox"/>	<input checked="" type="checkbox"/>	<input type="checkbox"/>
<input type="checkbox"/>	<input type="checkbox"/>	_____ in.	_____	_____	_____ in.	<input type="checkbox"/>	<input type="checkbox"/>	<input type="checkbox"/>	<input type="checkbox"/>
<input type="checkbox"/>	<input type="checkbox"/>	_____ in.	_____	_____	_____ in.	<input type="checkbox"/>	<input type="checkbox"/>	<input type="checkbox"/>	<input type="checkbox"/>

Perforations: Yes No Type of perforator used _____
No. of perforations _____ Size of perforations _____ in. by _____ in.
Perforated from _____ ft. to _____ ft. below ground surface

Screens: Yes No K-Packer \Rightarrow Depth 252 ft.
Manufacturer's Name Rosco Moss
Type wire wraps Model No. _____
Diameter 7.5 in. Slot size 100 in. from 255 ft. to 285 ft.
Diameter _____ in. Slot size _____ in. from _____ ft. to _____ ft.

Sand/Filter pack: Yes No Size of pack material .375 in.
Materials placed from 275 ft. to 285 ft.

Surface Seal: Yes No To what depth? 30' ft.
Material used in seal Bentonite 3/8" chips Hole plug
Did any strata contain unusable water? Yes No
Type of water? _____ Depth of strata _____
Method of sealing strata off _____

Pump: Manufacturer's Name _____ Type: _____
H.P. _____ Pump intake depth: _____ ft. Designed flow rate: _____ gpm

Water Levels: Land-surface elevation above mean sea level _____ ft.
Stick-up of top of well casing 3 ft. above ground surface
Static water level 188.5 ft. below top of well casing Date _____
Artesian pressure _____ lbs. per square inch Date _____
Artesian water is controlled by _____ (cap, valve, etc.)

Well Tests:
Was a pumping test performed? No Yes \Rightarrow by whom? Holt Services Inc.
Yield _____ gpm with _____ ft. drawdown after _____ hrs.
Yield _____ gpm with _____ ft. drawdown after _____ hrs.
Yield 73 gpm with 58.85 ft. drawdown after 24 hrs.
Recovery data (time = zero when pump is turned off - water level measured from well top to water level)

Time	Water Level	Time	Water Level	Time	Water Level
18	208	_____	_____	_____	_____
86	197	_____	_____	_____	_____
274	191	_____	_____	_____	_____

 Date of pumping test 8/17/21
 Bailer test _____ gpm with _____ ft. drawdown after _____ hrs.
 Air test _____ gpm with stem set at _____ ft. for _____ hrs. } Date _____
 Artesian flow _____ gpm
 Temperature of water _____ °F Was a chemical analysis made? Yes No

Notice of Intent No. WE44307

Unique Ecology Well ID Tag No. EJE 653

Site Well Name (if more than one well): Nisqually State Park

Water Right Permit/Certificate No. _____

Property Owner Name Washington State Parks Recreation

Well Street Address Marcel Prairie Rd

City Eatonville County Pierce - 27

Tax Parcel No. 0418194008

Was a variance approved for this well? Yes No

If yes, what was the variance for? _____

Location (see instructions on page 2): WWM or EWM

NE 1/4-1/4 of the SE 1/4; Section 19 Township 16N Range 4E

Latitude (Example: 47.12345) 48.856151

Longitude (Example: -120.12345) -122.342489

Driller's Log/Construction or Decommission Procedure

Formation: Describe by color, character, size of material and structure, and the kind and nature of the material in each layer penetrated, with at least one entry for each change of information. Use additional sheets if necessary.

Material	From	To
Sand	0'	7'
Till gray with black	7'	58'
Clay with gravel	58'	61'
Clay and sand	61'	75'
Green rock and sand	75'	80'
Gray and black sand with gravel	80'	102'
Silt stone	102'	115'
Gravel and sand	115'	126'
Green clay	126'	158'
Sandstone with fine clay lenses	158'	192'
Gravel and sand	192'	220'
Clay	220'	225'
Gravel	225'	275'

RECEIVED
By WELL CONSTRUCTION AND LICENSING OFFICE at 8:04 am, Oct 13, 2021

Start Date 07/06/2021 Completed Date 8/18/21

WELL CONSTRUCTION CERTIFICATION: I constructed and/or accept responsibility for construction of this well, and its compliance with all Washington well construction standards. Materials used and the information reported above are true to my best knowledge and belief.

Driller Trainee PE - Print Name Christopher Perry

Signature _____

License No. 3252

If TRAINEE: Sponsor's License No. _____

Sponsor's Signature _____

Drilling Company Holt Services Inc

Address 10621 Todd rd East

City, State, Zip Edgewood, WA, 98372

Contractor's

Registration No. HOLTSSI898JG Date 8/24/21

The Department of Ecology does NOT warranty the Data and/or information on this well report.

SOIL CLASSIFICATION CHART

MAJOR DIVISIONS			SYMBOLS		TYPICAL DESCRIPTIONS
			GRAPH	LETTER	
COARSE GRAINED SOILS	GRAVEL AND GRAVELLY SOILS	CLEAN GRAVELS <small>(LITTLE OR NO FINES)</small>		GW	WELL-GRADED GRAVELS, GRAVEL - SAND MIXTURES
		GRAVELS WITH FINES <small>(APPRECIABLE AMOUNT OF FINES)</small>		GP	POORLY-GRADED GRAVELS, GRAVEL - SAND MIXTURES
		GRAVELS WITH FINES <small>(APPRECIABLE AMOUNT OF FINES)</small>		GM	SILTY GRAVELS, GRAVEL - SAND - SILT MIXTURES
	SAND AND SANDY SOILS	CLEAN SANDS <small>(LITTLE OR NO FINES)</small>		SW	WELL-GRADED SANDS, GRAVELLY SANDS
		SANDS WITH FINES <small>(APPRECIABLE AMOUNT OF FINES)</small>		SP	POORLY-GRADED SANDS, GRAVELLY SAND
		SANDS WITH FINES <small>(APPRECIABLE AMOUNT OF FINES)</small>		SM	SILTY SANDS, SAND - SILT MIXTURES
FINE GRAINED SOILS	SILTS AND CLAYS	LIQUID LIMIT LESS THAN 50		ML	INORGANIC SILTS, ROCK FLOUR, CLAYEY SILTS WITH SLIGHT PLASTICITY
		LIQUID LIMIT LESS THAN 50		CL	INORGANIC CLAYS OF LOW TO MEDIUM PLASTICITY, GRAVELLY CLAYS, SANDY CLAYS, SILTY CLAYS, LEAN CLAYS
		LIQUID LIMIT LESS THAN 50		OL	ORGANIC SILTS AND ORGANIC SILTY CLAYS OF LOW PLASTICITY
	SILTS AND CLAYS	LIQUID LIMIT GREATER THAN 50		MH	INORGANIC SILTS, MICACEOUS OR DIATOMACEOUS SILTY SOILS
		LIQUID LIMIT GREATER THAN 50		CH	INORGANIC CLAYS OF HIGH PLASTICITY
		LIQUID LIMIT GREATER THAN 50		OH	ORGANIC CLAYS AND SILTS OF MEDIUM TO HIGH PLASTICITY
HIGHLY ORGANIC SOILS				PT	PEAT, HUMUS, SWAMP SOILS WITH HIGH ORGANIC CONTENTS

NOTE: Multiple symbols are used to indicate borderline or dual soil classifications

Sampler Symbol Descriptions

	2.4-inch I.D. split barrel
	Standard Penetration Test (SPT)
	Shelby tube
	Piston
	Direct-Push
	Bulk or grab
	Continuous Coring

Blowcount is recorded for driven samplers as the number of blows required to advance sampler 12 inches (or distance noted). See exploration log for hammer weight and drop.

"P" indicates sampler pushed using the weight of the drill rig.

"WOH" indicates sampler pushed using the weight of the hammer.

NOTE: The reader must refer to the discussion in the report text and the logs of explorations for a proper understanding of subsurface conditions. Descriptions on the logs apply only at the specific exploration locations and at the time the explorations were made; they are not warranted to be representative of subsurface conditions at other locations or times.

ADDITIONAL MATERIAL SYMBOLS

SYMBOLS		TYPICAL DESCRIPTIONS
GRAPH	LETTER	
	AC	Asphalt Concrete
	CC	Cement Concrete
	CR	Crushed Rock/Quarry Spalls
	SOD	Sod/Forest Duff
	TS	Topsoil

Groundwater Contact



Measured groundwater level in exploration, well, or piezometer



Measured free product in well or piezometer

Graphic Log Contact



Distinct contact between soil strata



Approximate contact between soil strata

Material Description Contact



Contact between geologic units



Contact between soil of the same geologic unit

Laboratory / Field Tests

%F	Percent fines
%G	Percent gravel
AL	Atterberg limits
CA	Chemical analysis
CP	Laboratory compaction test
CS	Consolidation test
DD	Dry density
DS	Direct shear
HA	Hydrometer analysis
MC	Moisture content
MD	Moisture content and dry density
Mohs	Mohs hardness scale
OC	Organic content
PM	Permeability or hydraulic conductivity
PI	Plasticity index
PL	Point load test
PP	Pocket penetrometer
SA	Sieve analysis
TX	Triaxial compression
UC	Unconfined compression
VS	Vane shear

Sheen Classification

NS	No Visible Sheen
SS	Slight Sheen
MS	Moderate Sheen
HS	Heavy Sheen

Key to Exploration Logs



Figure A-1

Start Drilled	9/23/2021	End	9/23/2021	Total Depth (ft)	31.5	Logged By	OA	Checked By		Driller	Holocene Drilling, Inc.	Drilling Method	Sonic
Surface Elevation (ft) Vertical Datum	665 NAVD88			Hammer Data	140 (lbs) / 30 (in) Drop			Drilling Equipment	GeoProbe 8140LC				
Latitude Longitude	46.8558 -122.34188			System Datum	WA State Plane South NAD83 (feet)			See "Remarks" section for groundwater observed					
Notes:													

Elevation (feet)	FIELD DATA					Graphic Log	Group Classification	MATERIAL DESCRIPTION	Moisture Content (%)	Fines Content (%)	REMARKS
	Depth (feet)	Interval Recovered (in)	Blows/foot	Collected Sample	Sample Name Testing						
0						DUF	Forest duff				
5	7	33		1	SM	Tan fine silty sand with gravel (dense, moist) (outwash/ice contact)		4	15		
10		80/6"		4	GM	Gray silty gravel with sand (very dense, moist) (outwash/ice contact)		6	21	(Density likely due to gravel)	Broken SPT sampler, possibly due to boulder
15	5	50/6"		6	GM	Tan-brown fine to coarse silty sand with gravel (very dense, wet) (outwash/ice contact)		8	15		Groundwater observed at approximately 12 feet at time of drilling
20	18	53		7	GM	Dark gray silty gravel with sand (very dense, moist) (outwash/ice contact)		15	29		
25	18	70/6"		10A	ML	Dark gray sandy silt (hard, moist) (Mashel Formation)		31	56		
				10B							
				11	SM	Dark gray silty sand (very dense, moist) (Mashel Formation)					
30	18	34		12 SA	ML	Dark gray silt with sand (Mashel Formation)		30	79		

Note: See Figure A-1 for explanation of symbols.
Coordinates Data Source: Horizontal approximated based on Topographic Survey. Vertical approximated based on Topographic Survey.

Log of Boring WW-1



Project: Nisqually State Park, Proposed WWTP and SSL
Project Location: Pierce County, Washington
Project Number: 2935-067-01

Date: 10/14/21 Path: \\GEOENGINEERS\COM\WAN\PROJECTS\2_2935067\GINT\293506701.GPJ DBLibrary\Library\GEOENGINEERS_DF_STD_US_JUNE_2017.GLB\GEB_GEO TECH_STANDARD_MF_NO_GW

Start Drilled	9/23/2021	End	9/23/2021	Total Depth (ft)	31.5	Logged By	OA	Checked By		Driller	Holocene Drilling, Inc.	Drilling Method	Sonic
Surface Elevation (ft) Vertical Datum	665 NAVD88			Hammer Data	140 (lbs) / 30 (in) Drop			Drilling Equipment	GeoProbe 8140LC				
Latitude	46.85555			System Datum	WA State Plane South NAD83 (feet)			See "Remarks" section for groundwater observed					
Longitude	-122.34206												
Notes:													

Elevation (feet)	FIELD DATA					Graphic Log	Group Classification	MATERIAL DESCRIPTION	Moisture Content (%)	Fines Content (%)	REMARKS
	Depth (feet)	Interval Recovered (in)	Blows/foot	Collected Sample	Sample Name Testing						
0						DUF	Forest duff				
5	1	50/2"		1		SM	Tan silty fine to medium sand with occasional gravel, cobbles and boulders (loose, moist) (outwash/ice contact)				
660											
5							Grades to very dense			Rock in shoe; very slow drilling from 5 to 10 feet below the ground surface	
10	2	50/2"		3		GM	Gray gravel with sand, cobbles and boulders (very dense, moist) (outwash/ice contact)	4	21	Boulders shifted drill alignment	
665											
10											
15	5	50/1"		4				11	19	Drilled through rock	
660											
15											
20	18	70/6"		6		SM	Brown silty fine sand with oxidation staining (very dense, moist to wet) (Mashel Formation)	9	22		
645											
20						SM	Dark gray silty sand (very dense, moist) (Mashel Formation)	30	40	Very difficult drilling	
640											
25	18	55		7							
635											
25								12	8		
30						SP-SM	Gray sand with silt and occasional gravel (very dense, wet) (Mashel Formation)				

Note: See Figure A-1 for explanation of symbols.
Coordinates Data Source: Horizontal approximated based on Topographic Survey. Vertical approximated based on Topographic Survey.

Log of Boring WW-2



Project: Nisqually State Park, Proposed WWTP and SSL
Project Location: Pierce County, Washington
Project Number: 2935-067-01

Date: 10/14/21 Path: \\GEOENGINEERS\COM\WAN\PROJECTS\2_2935067\GINT\2935067-01.GPJ DBLibrary\Library\GEOENGINEERS_DF_STD_US_JUNE_2017.GLB\GEB_GEO TECH_STANDARD_%F_NO_GW

APPENDIX B
Report Limitations and Guidelines for Use

APPENDIX B REPORT LIMITATIONS AND GUIDELINES FOR USE¹

This appendix provides information to help you manage your risks with respect to the use of this report.

Read These Provisions Closely

It is important to recognize that the geoscience practices (geotechnical engineering, geology and environmental science) rely on professional judgment and opinion to a greater extent than other engineering and natural science disciplines, where more precise and/or readily observable data may exist. To help clients better understand how this difference pertains to our services, GeoEngineers includes the following explanatory “limitations” provisions in its reports. Please confer with GeoEngineers if you need to know more how these “Report Limitations and Guidelines for Use” apply to your project or site.

Geotechnical Services are Performed for Specific Purposes, Persons and Projects

This report has been prepared for Robert W. Droll Landscape Architects and for the Project(s) specifically identified in the report. The information contained herein is not applicable to other sites or projects.

GeoEngineers structures its services to meet the specific needs of its clients. No party other than the party to whom this report is addressed may rely on the product of our services unless we agree to such reliance in advance and in writing. Within the limitations of the agreed scope of services for the Project, and its schedule and budget, our services have been executed in accordance with our Agreement with Robert W. Droll Landscape Architects dated July 6, 2021 and generally accepted geotechnical practices in this area at the time this report was prepared. We do not authorize, and will not be responsible for, the use of this report for any purposes or projects other than those identified in the report.

A Geotechnical Engineering or Geologic Report is based on a Unique Set of Project-Specific Factors

This report has been prepared for Nisqually State Park site in Pierce County, Washington. GeoEngineers considered a number of unique, project-specific factors when establishing the scope of services for this project and report. Unless GeoEngineers specifically indicates otherwise, it is important not to rely on this report if it was:

- Not prepared for you,
- Not prepared for your project,
- Not prepared for the specific site explored, or
- Completed before important project changes were made.

For example, changes that can affect the applicability of this report include those that affect:

¹ Developed based on material provided by GBA, GeoProfessional Business Association; www.geoprofessional.org.

- The function of the proposed structure;
- Elevation, configuration, location, orientation or weight of the proposed structure;
- Composition of the design team; or
- Project ownership.

If changes occur after the date of this report, GeoEngineers cannot be responsible for any consequences of such changes in relation to this report unless we have been given the opportunity to review our interpretations and recommendations. Based on that review, we can provide written modifications or confirmation, as appropriate.

Environmental Concerns are Not Covered

Unless environmental services were specifically included in our scope of services, this report does not provide any environmental findings, conclusions, or recommendations, including but not limited to, the likelihood of encountering underground storage tanks or regulated contaminants.

Subsurface Conditions Can Change

This geotechnical or geologic report is based on conditions that existed at the time the study was performed. The findings and conclusions of this report may be affected by the passage of time, by man-made events such as construction on or adjacent to the site, new information or technology that becomes available subsequent to the report date, or by natural events such as floods, earthquakes, slope instability or groundwater fluctuations. If more than a few months have passed since issuance of our report or work product, or if any of the described events may have occurred, please contact GeoEngineers before applying this report for its intended purpose so that we may evaluate whether changed conditions affect the continued reliability or applicability of our conclusions and recommendations.

Geotechnical and Geologic Findings are Professional Opinions

Our interpretations of subsurface conditions are based on field observations from widely spaced sampling locations at the site. Site exploration identifies the specific subsurface conditions only at those points where subsurface tests are conducted or samples are taken. GeoEngineers reviewed field and laboratory data and then applied its professional judgment to render an informed opinion about subsurface conditions at other locations. Actual subsurface conditions may differ, sometimes significantly, from the opinions presented in this report. Our report, conclusions and interpretations are not a warranty of the actual subsurface conditions.

Geotechnical Engineering Report Recommendations are Not Final

We have developed the following recommendations based on data gathered from subsurface investigation(s). These investigations sample just a small percentage of a site to create a snapshot of the subsurface conditions elsewhere on the site. Such sampling on its own cannot provide a complete and accurate view of subsurface conditions for the entire site. Therefore, the recommendations included in this report are preliminary and should not be considered final. GeoEngineers' recommendations can be finalized only by observing actual subsurface conditions revealed during construction. GeoEngineers cannot assume responsibility or liability for the recommendations in this report if we do not perform construction observation.

We recommend that you allow sufficient monitoring, testing and consultation during construction by GeoEngineers to confirm that the conditions encountered are consistent with those indicated by the explorations, to provide recommendations for design changes if the conditions revealed during the work differ from those anticipated, and to evaluate whether earthwork activities are completed in accordance with our recommendations. Retaining GeoEngineers for construction observation for this project is the most effective means of managing the risks associated with unanticipated conditions. If another party performs field observation and confirms our expectations, the other party must take full responsibility for both the observations and recommendations. Please note, however, that another party would lack our project-specific knowledge and resources.

A Geotechnical Engineering or Geologic Report Could Be Subject to Misinterpretation

Misinterpretation of this report by members of the design team or by contractors can result in costly problems. GeoEngineers can help reduce the risks of misinterpretation by conferring with appropriate members of the design team after submitting the report, reviewing pertinent elements of the design team's plans and specifications, participating in pre-bid and preconstruction conferences, and providing construction observation.

Do Not Redraw the Exploration Logs

Geotechnical engineers and geologists prepare final boring and testing logs based upon their interpretation of field logs and laboratory data. The logs included in a geotechnical engineering or geologic report should never be redrawn for inclusion in architectural or other design drawings. Photographic or electronic reproduction is acceptable, but separating logs from the report can create a risk of misinterpretation.

Give Contractors a Complete Report and Guidance

To help reduce the risk of problems associated with unanticipated subsurface conditions, GeoEngineers recommends giving contractors the complete geotechnical engineering or geologic report, including these "Report Limitations and Guidelines for Use." When providing the report, you should preface it with a clearly written letter of transmittal that:

- Advises contractors that the report was not prepared for purposes of bid development and that its accuracy is limited; and
- Encourages contractors to conduct additional study to obtain the specific types of information they need or prefer.

Contractors are Responsible for Site Safety on Their Own Construction Projects

Our geotechnical recommendations are not intended to direct the contractor's procedures, methods, schedule or management of the work site. The contractor is solely responsible for job site safety and for managing construction operations to minimize risks to on-site personnel and adjacent properties.

Biological Pollutants

GeoEngineers' Scope of Work specifically excludes the investigation, detection, prevention or assessment of the presence of Biological Pollutants. Accordingly, this report does not include any interpretations, recommendations, findings or conclusions regarding the detecting, assessing, preventing or abating of Biological Pollutants, and no conclusions or inferences should be drawn regarding Biological Pollutants as

they may relate to this project. The term “Biological Pollutants” includes, but is not limited to, molds, fungi, spores, bacteria and viruses, and/or any of their byproducts.

A Client that desires these specialized services is advised to obtain them from a consultant who offers services in this specialized field.

Information Provided by Others

GeoEngineers has relied upon certain data or information provided or compiled by others in the performance of our services. Although we use sources that we reasonably believe to be trustworthy, GeoEngineers cannot warrant or guarantee the accuracy or completeness of information provided or compiled by others.

Geotechnical Engineering Services

Proposed Wastewater Treatment Plant and
Sanitary Sewer Line
Nisqually State Park
Pierce County, Washington

for

Robert W. Droll, Landscape Architects

October 21, 2021



Geotechnical Engineering Services

Proposed Wastewater Treatment Plant and
Sanitary Sewer Line
Nisqually State Park
Pierce County, Washington

for

Robert W. Droll, Landscape Architects

October 21, 2021



1101 South Fawcett Avenue, Suite 200
Tacoma, Washington 98402
253.383.4940

Geotechnical Engineering Services
Proposed Wastewater Treatment Plant and
Sanitary Sewer Line
Nisqually State Park
Pierce County, Washington

File No. 2935-067-01

October 21, 2021

Prepared for:

Robert W. Droll, Landscape Architects
4405 7th Avenue SE
Lacey, Washington 98503

Attention: Bob Droll

Prepared by:

GeoEngineers, Inc.
1101 South Fawcett Avenue, Suite 200
Tacoma, Washington 98402
253.383.4940

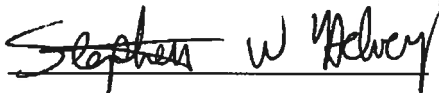

Stephen W. Helvey, LG, LEG, LHG
Senior Engineering Geologist



Debra C. Overbay, PE
Associate

SWH:DCO:leh



Disclaimer: Any electronic form, facsimile or hard copy of the original document (email, text, table, and/or figure), if provided, and any attachments are only a copy of the original document. The original document is stored by GeoEngineers, Inc. and will serve as the official document of record.

Table of Contents

1.0 INTRODUCTION AND PROJECT UNDERSTANDING.....	1
2.0 SCOPE OF SERVICES.....	2
3.0 SURFACE CONDITIONS.....	3
3.1. Geologic Conditions.....	3
4.0 FIELD EXPLORATION AND LABORATORY TESTING.....	4
4.1. Field Explorations.....	4
4.2. Laboratory Testing.....	4
4.3. Subsurface Conditions.....	4
4.3.1. WWTP.....	4
4.3.2. SSL.....	4
4.3.3. Groundwater.....	4
5.0 CONCLUSIONS AND RECOMMENDATIONS.....	5
5.1. Summary of Geotechnical Considerations.....	5
5.2. Site Preparation and Earthwork.....	6
5.2.1. General.....	6
5.2.2. Stripping and Clearing.....	6
5.2.3. Excavations.....	7
5.3. Temporary Cut Slopes.....	7
5.4. Temporary Shoring.....	8
5.4.1. General.....	8
5.4.2. Lateral Pressures for Conventional or Internally Braced Shoring.....	8
5.5. Temporary Dewatering.....	9
5.5.1. General.....	9
5.5.2. Pumped Wells.....	9
5.5.3. Open Excavation Pumping.....	9
5.5.4. Other Considerations.....	9
5.6. Subgrade Evaluation.....	10
5.7. Weather Considerations.....	10
5.8. Erosion and Sedimentation Control.....	11
5.9. Fill Materials.....	12
5.9.1. On-site Soils.....	12
5.9.2. Select Granular Fill.....	12
5.9.3. Pipe Bedding.....	12
5.9.4. Crushed Rock.....	12
5.10. Fill Placement and Compaction.....	12
5.10.1. General.....	12
5.10.2. Area Fills and Bases.....	13
5.10.3. Trench Backfill.....	13
5.11. Permanent Slopes.....	13
5.12. Foundation Support – At-Grade Structures.....	13
5.12.1. Shallow Foundations.....	13
5.12.2. Bearing Capacity.....	14

5.12.3. Footing Subgrade Preparation.....	14
5.12.4. Foundation Settlement	14
5.13.Slabs-On-Grade	14
5.14.Lateral Resistance	15
5.15.Below-Grade Structures.....	15
5.15.1. Lateral Earth Pressures	15
5.15.2. Buoyancy and Uplift.....	16
5.15.3. Foundation Support.....	16
5.16.Seismic Design Parameters	16
5.17.Liquefaction Potential.....	16
6.0 LIMITATIONS	17

LIST OF FIGURES

Figure 1. Vicinity Map
 Figures 2 and 3. Site Plan

APPENDICES

Appendix A. Field Explorations and Laboratory Testing
 Figure A-1 – Key to Exploration Logs
 Figures A-2 through A-12 – Logs of Test Pits
 Figures A-13 and A-17 – Sieve Analysis Results
 Appendix B. Proposed Maintenance Building and Drainage Basin 2 Test Pit Logs
 Appendix C. Report Limitations and Guidelines for Use

1.0 INTRODUCTION AND PROJECT UNDERSTANDING

This report presents the results of our geotechnical engineering study for a portion of the overall Nisqually State Park improvement project. The subject of this report is a proposed wastewater treatment plant (WWTP) and associated sanitary sewer line (SSL). Our understanding of this portion of the project is based on information provided by members of the design team.

The proposed WWTP is to be located generally north of the intersection of Mashel Prairie Road and an un-named road, which descends downward to the southwest toward the Nisqually River. The intersection is about 1 mile southwest of the intersection between State Route 7 (SR-7) and Mashel Prairie Road. Nearby planned features include the Park Maintenance facility. The proposed SSL is located along both sides of Mashel Prairie Road for a distance of about 4,200 feet northeast of the proposed WWTP.

The approximate area of the WWTP and SSL is shown in the Vicinity Map, Figure 1. The approximate WWTP site boundary is shown in Figure 2. The approximate locations of the proposed SSL is shown in Figure 3.

We understand the project is in the preliminary stages and as such a final site layout has not been developed for the WWTP. A proposed layout of the SSL with proposed manhole locations has also not been developed. Proposed features for this part of the overall project consist of the following:

WWTP At-Grade Structures

- Operations building, single-story, slab-on-grade structure
- Mechanical building, 1.5 stories, slab on grade structure
- Odor Control Unit
- Non-Potable Water Tank, about 6,000 gallon capacity

WWTP Below-Grade Structures

- Cast-in-place reinforced concrete process tank, 15 x 80 x 12-feet deep
- Equalization tank, likely polyvinyl chloride (PVC) or fiberglass reinforced plastic (FBR) founded 16 to 18 feet below grade
- Concrete influent pump station founded about 22 feet below grade

SSL

- Below-grade transmission pipes from the various improvement site areas to the WWTP. We understand these pipes will likely be about 8 to 12 inches in diameter and less than 6 feet below grade. The SSL will be located along Mashel Prairie Road. This feature will be about 4,200 feet long and may contain up to 14 manhole structures.

We understand that the above grade structures are generally lightly loaded with the exception of the water tank. The below grade structures are settlement sensitive.

Our work was generally performed in accordance with our revised proposal, dated February 11, 2021. We received written authorization on June 10, 2021.

2.0 SCOPE OF SERVICES

The scope of services completed for this portion of the project includes the following tasks.

1. Mobilized to the site to mark exploration locations. Clear publicly owned utilities at the exploration locations by contacting the One-Call utility located service.
2. Schedule and observe the completion of three borings, to depths of about 30 feet each, within the Wastewater Treatment Plant area. The explorations were completed using track-mounted sonic drilling equipment.
3. Construct a 2-inch diameter monitoring well in one of the borings. Develop the monitoring well using a small submersible pump. Measure groundwater levels in the monitoring well and install a pressure transducer in the well.
4. Complete eight test pit explorations on the west side of Mashel Prairie Road. The test pits were excavated to depths from 6 to 8 feet below existing grade.
5. Log soils encountered in the explorations in general accordance with ASTM International (ASTM) D 1586 procedures.
6. Collect samples from the explorations and submit selected samples for laboratory testing. Samples were collected on a near continuous basis in the borings. Samples in the test pit were collected from the trackhoe bucket.
7. Document observations of groundwater, if any, encountered in the explorations.
8. Evaluate pertinent physical and engineering characteristics of the soils based on the results of the field exploration, laboratory testing and our experience.
9. Perform evaluations and engineering analyses, and provide conclusions and recommendations for the proposed WWTP improvements. These included the following:
 - An evaluation of feasible shoring methods for the proposed below-grade structures. This included conventional shoring (slide rails, internally braced, trench boxes, etc.) and open cuts with partial shoring.
 - Lateral earth pressures on temporary excavation shoring for level ground conditions and sloping backfill, where appropriate.
 - Dewatering considerations.
 - Shallow foundation recommendations including allowable bearing pressures, lateral resistance and estimates of expected foundation settlement.
 - Slab-on-grade and mat foundation recommendations including subgrade preparation, modulus, and allowable bearing/areal loading and post-construction settlement.
 - Lateral soil pressures on permanent below-grade structures for level ground conditions.
 - Geotechnical parameters to evaluate buoyancy uplift resistance.
10. Perform engineering analyses and provide conclusions and recommendations for conventional trenching techniques to be used to install the proposed SSL. This includes the following:
 - Geotechnical parameters for trench shoring design.
 - Trench excavation considerations.

- Bedding and backfilling of pipelines and manholes.
 - Dewatering requirements.
11. Provide recommendations for earthwork and site preparation including suitability of on-site soils for reuse in backfill, placement and compaction of backfill, and mitigation of unsuitable soil conditions. This includes an evaluation of the effects of weather and/or construction equipment on site soils.
 12. Provide recommendations regarding erosion and sedimentation control, including sequencing of excavation activities to minimize disturbance of the area.
 13. Discuss seismicity at the WWTP site and evaluate the earthquake engineering aspects of the project, including liquefaction potential.

3.0 SURFACE CONDITIONS

The proposed WWTP is located on a relatively flat upland area. Site grades are slightly undulatory, varying from about Elevation 662 to about Elevation 666 feet. The project area is currently covered in fir and alder trees with moderate to thick brush.

The proposed SSL follows Mashel Prairie Road from the WWTP area about 4,200 feet northeast of the WWTP site, as shown in Figures 1 and 2. The northern approximately 2,500 feet of the line is located in a relatively flat plain that ranges from about 716 to 707 feet in elevation. The SSL traverses a low slope between test pit SW-6 and a utility easement. The slope varies in elevation from about 705 feet to about 698 feet. The remainder of the SSL slopes slightly downward to the southwest from 698 feet elevation to about 665 feet elevation.

A proposed maintenance complex is to be located south of the WWTP, as shown in Figure 2. Various campgrounds and other proposed park features are to be located east and west of the proposed SSL as shown in Figure 3. Geotechnical recommendations for these and other park development features are provided in separate reports.

3.1. Geologic Conditions

Geologic conditions at the site and nearby area were evaluated by reviewing the Washington State Department of Natural Resources “Geologic Map of the Centralia Quadrangle, Washington, 1987.” Materials mapped at and in the site area comprise Vashon Drift, Undifferentiated (map unit Qdv). This material is mapped over a broad area at and around the project site. These geologic materials are described as glacial outwash with silts, clays, lacustrine deposits and some ice contact deposits.

Mashel Formation sedimentary rocks (Tmh) are mapped beneath the Qdv material in the Ohop River valley wall, generally west of the site. Mashel Formation rocks are described as varying from claystone, sandstone to poorly cemented basaltic gravel.

4.0 FIELD EXPLORATION AND LABORATORY TESTING

4.1. Field Explorations

Soil and groundwater conditions within the WWTP area were explored by completing three borings on September 23, 2021. Eight test pits were completed within the SSL alignment on July 8, 2021. The approximate locations of the explorations completed for this project are presented on Figures 2 and 3. Details of the field exploration program and logs of the explorations are presented in Appendix A, Field Explorations and Laboratory Testing.

4.2. Laboratory Testing

Soil samples obtained during our site exploration were taken to GeoEngineers, Inc.'s (GeoEngineers) laboratory for further evaluation. Selected samples were tested for the determination of moisture content and grain-size distribution (sieve analysis). Descriptions of the laboratory testing, and the test results are presented in the exploration logs and in Appendix A.

4.3. Subsurface Conditions

4.3.1. WWTP

Variable soil conditions were encountered in the three borings. Approximately 6 to 8 inches of forest duff/vegetation was encountered at the ground surface in each exploration.

Beneath the duff material, we encountered what we interpret to be ice-contact/outwash deposits to depths ranging from about 13 to 21 feet in the three borings. The ice contact/outwash consists of dense silty sand with gravel, cobbles and boulders and dense to very dense silty gravel with sand. Soil densities, derived from driven soil samples, are likely over-stated in this unit due to the sampler size and presence of oversized particles (gravel, cobbles and boulders).

Interlayered hard silt with sand and very dense sand with silt material was encountered beneath the ice contact/outwash deposit in each boring. This material appears to be Mashel Formation bedrock. The bedrock material was encountered to the full depth explored in the borings.

The contact between the ice contact/outwash material and the bedrock appears to vary across the site. Within the Maintenance Building area, the contact was encountered at about 7 feet below ground surface in TH-1C (Appendix B). The contact was encountered at 13 feet in WW-3, 17 feet in WW-2 and 21.5 feet in WW-3.

Boulders and cobbles were encountered in all the borings and in the Maintenance Building test pits.

4.3.2. SSL

Four to six inches of forest duff material was encountered in all of the test pits (SWP-1 through SWP-8). Granular medium dense to dense outwash was then encountered to the full depth explored in all of the test pits. Most of this material was gravel with sand or gravel with sand and silt. A layer of medium dense sand was encountered in SWP-6.

4.3.3. Groundwater

Groundwater was observed in the borings at depths ranging from about 12 to 14 feet during drilling. Groundwater was measured at a depth of 11.53 feet below ground surface in WW-3 on October 7, 2021.

Groundwater in this well appears to be perched on the Mashel Formation bedrock material. Groundwater was not encountered in the test pit explorations completed for the SSL.

Groundwater levels will likely rise at the site during the normal wet late fall/winter months. We expect that future groundwater levels at the site will vary with precipitation and the depth to the Mashel Formation bedrock beneath the ice contact/outwash material.

5.0 CONCLUSIONS AND RECOMMENDATIONS

5.1. Summary of Geotechnical Considerations

Based on our observations and the results of our subsurface exploration and testing program, it is our opinion that the site is suitable for the proposed WWTP and SSL projects. A summary of the primary geotechnical considerations is provided below. The summary is presented for introductory purposes only and should be used in conjunction with the detailed recommendations presented in this report.

- The near-surface soils within the WWTP area contain a moderate to high percentage of fines and are sensitive to small changes in moisture content. These soils are susceptible to disturbance from construction traffic when the moisture content is more than a few percent above the optimum moisture content for compaction. These soils will be difficult, if not impossible, to work or compact when wet or if earthwork is performed in wet weather. Portions of the gravel soils contain a low to moderate percentage of fines. These soils may be suited for earthwork under wet and dry conditions. Cobbles and boulders were encountered in our explorations and should be anticipated during grading activities and site excavations.
- Groundwater levels observed during drilling and measured in well WW-3 are above foundation grades for several of the proposed below-grade structures, requiring up to approximately 12 feet of drawdown based on groundwater measurements to date. Dewatering will be required to construct these features regardless of season. The volume of dewatering will likely be less during typical summer/early fall months. We recommend that earthwork and construction be scheduled to avoid the normal wet late fall and winter months, when groundwater levels will be highest. Dewatering considerations using individually pumped wells are discussed in a subsequent section.
- Temporary shoring recommendations for conventional methods (slide rails, internally braced, trench boxes, and partial shoring) are discussed in Section 5.4. We recommend temporary slopes be inclined at 1½H:1V (horizontal to vertical) or flatter. These slopes may need to be modified depending on the total excavation depth, seepage conditions, localized sloughing, and the dewatering methods utilized during construction.
- We recommend all new fill placed below new structures, parking and driveway areas be placed and compacted as structural fill. In areas where the structural fill is to be placed, the topsoil and root mass must be removed, and the existing subgrade soils should be evaluated prior to fill placement to identify soft or unsuitable soils. Subgrade evaluation should be accomplished by either probing or proof-rolling with heavy, rubber-tired construction equipment.
- The proposed at-grade structures may be satisfactorily supported on continuous and isolated shallow foundations supported on the recompacted native gravel soils or on a minimum 2-foot thickness of compacted structural fill. We recommend an allowable soil bearing pressure of 3,000 pounds per square foot (psf) for design of shallow footings supported as recommended in this report.

- We recommend slabs-on-grade be underlain by a minimum 18-inch thickness of on-site soils or structural fill compacted to a minimum of 95 percent of the maximum dry density (MDD) per ASTM D 1557. The upper 4 inches should consist of a capillary break layer. Capillary break material should consist of well-graded sand and gravel or crushed rock that is a coarse-grained aggregate with negligible sand and silt.
- Permanent structures that extend below the water table will be subjected to buoyancy and uplift. Groundwater may be encountered at about 10 feet below the ground surface (or higher depending on winter conditions). Based on the subsurface soil consistency and type encountered in the borings, we estimate minor ground settlement (less than 1 inch) may occur at the site as the result of lowering the water table.
- Weakly cemented Mashel Formation bedrock (silt with sand/sand with silt) was encountered at variable depths across the site. These materials will likely be encountered/exposed in excavations to construct below-grade structures and are in a hard/very dense condition. This unit and the above outwash layer will provide suitable bearing surfaces for the proposed below-grade structures. We recommend that foundation grades for the below-grade features be over-excavated a minimum of 12-inches to allow placement of a crushed rock base layer to provide protection and uniform support. An allowable bearing pressure of 5,000 psf can be used for design of the planned below-grade structures supported as recommended.

5.2. Site Preparation and Earthwork

5.2.1. General

Site development work will include removing existing trees and vegetation, stripping of forest duff/topsoil and root layer and completing relatively deep excavations to construct the various proposed project elements. The near-surface site soils encountered in our explorations are moisture sensitive due to moderate to high fines content. Deeper soils encountered in the SSL alignment do not appear to be moisture sensitive.

Grading and reuse of the moisture-sensitive soils is more practical during the dry season (typically July through September). Moisture conditioning necessary to obtain proper compaction of these soils will likely not be practical during the cooler and wetter winter months and may still present challenges during the normally dry summer months, particularly those soils in deep excavations. We recommend a contingency be included in the project budget and schedule for export of unsuitable wet on-site soil and import of select granular soil if earthwork will be performed during periods of wet weather.

The following sections provide our recommendations for earthwork, site development, and fill materials.

5.2.2. Stripping and Clearing

The existing trees, shrubs, topsoil, unsuitable soils and boulders should be stripped and removed from all proposed construction areas. Based on our explorations, the depth of stripping to remove unsuitable surface organic materials should generally vary between 6 and 12 inches. Greater stripping depths will be required to remove localized zones of loose or organic-rich soil and tree roots or if large boulders are encountered. The primary root systems for trees and shrubs should be completely removed. Required stripping depths should be evaluated based on observations during the stripping operation. Stripped organic material should be transported off site for disposal or processed and used as fill in landscaping areas. Excavations for boulder depressions should be backfilled with structural fill compacted to the densities indicated in Section 5.6 "Fill Placement and Compaction" of this report.

5.2.3. Excavations

Excavations ranging from about 13 feet to 22 feet below grade will be required for the below-grade WWTP structures (concrete process tank, equalization tank and concrete pump tank). Excavation depths for the SSL pipeline are 6 feet or less, based on preliminary information. Excavation depths for manholes is presently unknown.

Large excavators will likely be required to complete the WWTP excavations. The Mashel bedrock material will likely require large-toothed excavator buckets. We recommend that final preparation of footing and trench excavations be performed using a smooth-blade bucket to prevent excessive disturbance of the excavation base.

Boulders and large cobbles were encountered in the explorations and should be anticipated during grading and/or utility excavations. Accordingly, the contractor should be prepared to remove boulders, if encountered. Boulders may be removed from the site or buried in landscape areas. Voids caused by boulder removal must be backfilled with structural fill.

5.3. Temporary Cut Slopes

Temporary cut slopes and shoring will be required to construct the below-grade portions of the project. We recommend that temporary slopes in the ice contact/outwash soils be inclined at 1½H:1V (horizontal:vertical) or flatter. Flatter cut slopes may be necessary depending on control of groundwater seepage and dewatering methods. Where temporary open cut slopes are utilized, we recommend the following:

- No traffic, construction equipment or supplies should be allowed at the top of cut slopes for a distance of at least 10 feet from the top of the cut.
- Exposed soil along temporary cut slopes should be protected from surface erosion using waterproof tarps or Visqueen, when appropriate.
- Construction should be scheduled so that the length of time the temporary cut is left open is minimized.
- Erosion control measures should be constructed as appropriate to reduce runoff from the site.
- Surface water flow should be diverted away from all excavations.
- The general condition of the temporary cut slopes should be observed periodically by a geotechnical engineer to identify potential problems.

If temporary cut slopes experience excessive sloughing or raveling during construction, it may become necessary to modify the cut slopes to maintain safe working conditions and protect adjacent facilities or structures. Slopes experiencing excessive sloughing or raveling can be flattened, supported with shoring, or additional dewatering can be provided if the poor slope performance is related to groundwater seepage.

Temporary cut slopes and shoring must comply with the provisions of Title 296 Washington Administrative Code (WAC), Part N, "Excavation, Trenching and Shoring." The contractor performing the work must have the primary responsibility for protection of workmen and adjacent improvements, determining whether shoring is required, and for establishing the safe inclination for open-cut slopes.

5.4. Temporary Shoring

5.4.1. General

Excavations deeper than 4 feet should be shored if temporary cut slopes are not employed. Because of the diversity of available shoring systems and construction techniques, the design of temporary shoring is most appropriately left up to the contractor proposing to complete the installation. We recommend that the shoring be designed by a PE licensed in the State of Washington, and that the PE-stamped shoring plans and calculations be submitted to Robert W. Droll, Landscape Architects (RWD), Washington State Parks and the Engineer for review prior to construction. The following paragraphs present general recommendations for the type of shoring system and design parameters that we conclude are likely to be considered by prospective bidders.

Multiple shoring alternatives can be considered for the proposed below-grade structures. Shoring systems should incorporate a dewatering plan. Our recommendations regarding conventional or internally braced shoring are presented in the following sections.

5.4.2. Lateral Pressures for Conventional or Internally Braced Shoring

The lateral soil pressures acting on temporary shoring will depend on the nature and density of the soil behind the wall, the inclination of the ground surface behind the wall, and the groundwater level. For walls that are free to yield at the top at least one thousandth of the height of the wall (i.e., wall height times 0.001), soil pressures will be less than if movement is restrained. The design of temporary shoring should allow for lateral pressures exerted by the adjacent soil, and for surcharge loads resulting from traffic, construction equipment, temporary stockpiles adjacent to the excavation, etc. Lateral load resistance can be mobilized through the use of braces, tiebacks, anchor blocks, and passive pressures on members that extend below the bottom of the excavation. Temporary shoring used to support trench excavations typically uses internal bracing such as hydraulic shoring or trench boxes.

We recommend that yielding walls retaining the medium dense to dense native soils be designed using an equivalent fluid density of 35 pounds per cubic foot (pcf), for horizontal ground surfaces and 55 pcf for a 2H:1V backslope if partial shoring is considered. For non-yielding (i.e., braced) systems, we recommend that the shoring be designed for a uniform lateral pressure of $22H$ in psf, where H is the depth of the planned excavation in feet below a level ground surface. These values assume that the soil behind the shoring has been dewatered such that the groundwater table is at least 2 feet below the base of the excavation. Temporary dewatering recommendations are discussed in a subsequent section of this report. If the dewatering system is not designed to lower the groundwater level behind the shoring walls, hydrostatic pressures must be included in the shoring design. For this condition, temporary shoring should be designed using a lateral pressure equal to an equivalent fluid density of 80 pcf, for horizontal ground conditions adjacent to the excavation.

The above lateral soil pressures do not include traffic, sloping ground, or construction surcharges that should be added separately, where present. The shoring design must incorporate all appropriate surcharges.

The soil pressure available to resist lateral loads against shoring is a function of the passive resistance that can develop on the face of below-grade elements of the shoring as those elements move horizontally into the soil. The allowable passive resistance on the face of embedded shoring elements may be computed using an equivalent fluid density of 170 pcf below the water table and 320 pcf above the water table. This passive equivalent fluid density value includes a factor of safety of about 1.5.

5.5. Temporary Dewatering

5.5.1. General

We anticipate that all of the proposed below-grade WWTP structures will likely encounter groundwater seepage, based on our observations during drilling. It is possible that the SSL excavations will not encounter groundwater, if those excavations are 6 feet or less and the excavations are completed during the dry summer months.

At the WWTP, we expect groundwater to flow from the ice contact/outwash material, above the Mashel Formation bedrock. Groundwater levels at the site are being measured in WW-3 using a pressure transducer. Groundwater level data collected during the winter of 2021-2022, spring and summer of 2022 will likely provide a more accurate indication of the optimum seasonal time period for construction.

5.5.2. Pumped Wells

Individually pumped high-capacity wells may be used to dewater the excavations. Pumped wells are generally the most effective dewatering method in areas where dewatering to deeper than about 15 feet below the ground surface (bgs) is necessary.

We recommend that all dewatering wells installed for this project be properly developed to remove fine sediment from the immediate vicinity of the well screens. Proper development is essential for producing efficient wells and helps to reduce the turbidity of the water discharged from each well. Filter packs consisting of graded sand, or sand and fine gravel should be installed around the well screens in areas where the aquifer contains a high percentage of fine sand and silt.

5.5.3. Open Excavation Pumping

If very highly permeable zones intersect the excavations, open pumping may be required to remove water that has seeped into the excavation. This is accomplished by pumping from sumps that have been excavated into the base of the trench. This form of passive dewatering should only be used when limited drawdown is required (e.g., less than about 3 feet), or to supplement pumped wells to remove excess water. Drainage ditches that are connected to the sump are typically excavated along the sidewalls at the base of the excavation or trench. The excavation for the sump and the drainage ditches should be backfilled with gravel or crushed rock to reduce the amount of erosion and associated sediment in the water pumped from the sump. In our experience, a slotted casing or perforated 55-gallon drum that is installed in the sump backfill provides a suitable housing for a submersible pump.

The amount of water removed from the excavation by open pumping should be minimized because of high turbidity levels. Temporary storage of dewatering effluent from the sumps in a settlement tank or basin may be required to meet discharge permit requirements and reduce sediment content prior to discharging the water to surface water courses. Open pumping will not adequately dewater the base of the excavations and might therefore lead to base instability unless a cutoff shoring system is utilized.

5.5.4. Other Considerations

We strongly advise against the use of small-diameter vacuum wellpoint systems for dewatering. These systems are limited in terms of pumping capacity and suction lift, both factors that will compromise the ability of these systems to fully dewater the excavations.

The disposal of water from dewatering operations should generally conform with requirements established in the Stormwater Pollution Prevention Plan (SWPPP), to be prepared for the project. We anticipate this would include options for the disposal of clean (non-turbid) water discharged from dewatering wells.

We recommend the contract specifications require that the contractor retain a specialty dewatering subcontractor to design and install an appropriate dewatering system that will operate in conjunction with the selected shoring method to adequately lower the groundwater level without adversely affecting adjacent facilities. The specifications should require the dewatering subcontractor be experienced in dewatering in the subsurface soil and groundwater conditions anticipated at the site.

Dewatering specifications should be written to address the conditions of the site, with a requirement that the contractor submit a detailed dewatering plan. To reduce the risk of low bids that misinterpret the shoring and dewatering requirements of the project, we recommend that the bid schedule require the contractor submit a one-page description of their shoring and dewatering concept for the project, and an acknowledgment that they have read this Geotechnical Engineering Report. The dewatering plan should include measures to be implemented if the dewatering system fails to achieve the required dewatering, or if groundwater levels rise in open excavations during construction.

The specifications should require that the contractor's shoring and dewatering plan be reviewed by GeoEngineers to assess whether the proposed method is feasible and that the design is consistent with our recommendations. A shoring and groundwater monitoring program may also be applicable depending on the construction sequencing at this site.

5.6. Subgrade Evaluation

After stripping and excavation to planned subgrade is complete, we recommend the exposed soils be proofrolled or probed and then compacted to a firm and unyielding condition. If dry weather conditions persist, the subgrades for at grade structures can be evaluated by proofrolling with a loaded dump truck or similar heavy rubber-tired construction equipment to identify soft, loose or unsuitable areas. Proofrolling must be conducted prior to placing fill. Below-grade subgrades can be evaluated using a small roller or by probing. If the subgrades are prepared during or exposed to wet weather, or groundwater, we recommend that they be evaluated by probing with a steel probe rod.

The proofrolling/probing should be observed by a qualified geotechnical engineer, who will evaluate the suitability of the subgrade and identify any areas of yielding. If soft or otherwise unsuitable areas revealed during proofrolling cannot be compacted to a stable and uniformly firm condition, we recommend that: (1) the subgrade soils be scarified (e.g., with a ripper or a farmer's disc), aerated and recompacted; or (2) the unsuitable soils be excavated to firm soil and replaced with structural fill, as recommended by the geotechnical engineer.

5.7. Weather Considerations

Soils encountered in our explorations contain a sufficient percentage of fines (silt) to be moisture sensitive. When the moisture content of these soils is appreciably above the optimum moisture content, these soils become muddy and unstable, operation of equipment on these soils will be difficult, and it will be difficult to meet the required compaction criteria. Additionally, disturbance of these near-surface soils should be expected if earthwork is completed during periods of wet weather.

The wet weather season generally begins in early November and continues through April in Western Washington; however, periods of wet weather may occur during any month of the year. The optimum earthwork period for these types of soils is typically June through October. If wet weather earthwork is unavoidable, we recommend that:

- Structural fill placed during the wet season or during periods of wet weather consist of gravel borrow (Section 9-03.14(1) of the 2020 Washington State Department of Transportation [WSDOT] Standard Specifications) with the added restriction that no more than 5 percent of the material passes the U.S. No. 200 sieve. The cleaner zones of outwash soils will likely be suitable based on this criteria.
- The ground surface in and around the work areas be sloped so that surface water is directed away from the work areas. The ground surface should be graded such that areas of ponded water do not develop. Measures should be taken by the contractor to prevent surface water from collecting in excavations and trenches. Measures should be implemented to remove surface water from the work area.

5.8. Erosion and Sedimentation Control

The site will be susceptible to erosion during wet weather conditions, particularly if large segments of exposed subgrades are exposed to rainfall. Development, implementation and adherence to an Erosion and Sedimentation Control Plan should reduce the project impact on erosion-prone areas. The Plan should be designed in accordance with applicable city, county and/or state standards. The Plan should incorporate basic planning principles, including:

- Scheduling grading and construction to reduce soil exposure.
- Re-vegetating or mulching denuded areas.
- Directing runoff away from exposed soils.
- Reducing the length and steepness of slopes with exposed soils.
- Decreasing runoff velocities.
- Preparing drainage ways and outlets to handle concentrated or increased runoff.
- Confining sediment to the project site.
- Inspecting and maintaining control measures frequently.

Some sloughing erosion and raveling of exposed or disturbed soil on slopes should be expected, particularly if the work is completed during the wet season. We recommend that disturbed soil be restored promptly so that surface runoff does not become channeled.

Temporary erosion protection should be used and maintained in areas with exposed or disturbed soils to help reduce erosion and transport of sediment to adjacent areas and receiving waters. Permanent erosion protection should be provided by paving, structure construction or landscape planting.

Until the permanent erosion protection is established, and the site is stabilized, site monitoring may be required by qualified personnel who will evaluate the effectiveness of the erosion control measures and recommend repairs and/or modifications as appropriate. Provision for modifications to the erosion control system based on monitoring observations should be included in the Erosion and Sedimentation Control Plan.

5.9. Fill Materials

The workability of material used as structural fill depends on the gradation and moisture content of the soil. As the amount of fines (material passing the U.S. No. 200 sieve) increases, soil becomes increasingly sensitive to small changes in moisture content and adequate compaction becomes more difficult, if not impossible to achieve. As discussed previously, we recommend that select granular fill or crushed rock be used as structural fill during the rainy season. The following paragraphs summarize the material requirements for fill and backfill.

5.9.1. On-site Soils

Soils encountered in our explorations may be considered for use as structural fill during periods of extended dry weather, provided they can be properly moisture conditioned and do not contain an unacceptable amount of organic materials. The clean gravel outwash soils encountered in the SSL test pits can likely be used as structural fill during wet and dry weather conditions. On-site materials used as structural fill must be free of roots, organic matter and other deleterious materials and particles larger than 3 inches in diameter.

5.9.2. Select Granular Fill

Select granular fill (pit run) used during the wet season should meet the criteria for gravel borrow as discussed in Section 5.3. Organic matter, debris, or other deleterious material must not be present. Granular fill used during periods of prolonged dry weather may have up to 12 percent passing a U.S. No. 200 sieve provided the material can be moisture conditioned and compacted to the minimum criteria.

5.9.3. Pipe Bedding

Trench backfill for the bedding and pipe zone must consist of well-graded granular material with a maximum particle size of $\frac{3}{4}$ inch and less than 5 percent passing the U.S. No. 200 sieve. The material must be free of roots, debris, organic matter, and other deleterious material.

5.9.4. Crushed Rock

Crushed rock fill must consist of clean, durable, crushed angular rock that has a maximum particle size of 4 inches, is well graded between coarse and fine sizes, and has less than 5 percent fines (material finer than a U.S. No. 200 sieve). A smaller maximum particle size will be required for some applications as discussed in other sections of this report. Gravel materials should be crushed to have at least two fractured faces. Organic matter, debris, or other deleterious material must not be present.

5.10. Fill Placement and Compaction

5.10.1. General

Fill soils should be compacted at a moisture content near optimum. The maximum allowable moisture content varies with the soil gradation and should be evaluated during construction. Fill and backfill material should be placed in uniform, horizontal lifts, and uniformly densified with vibratory compaction equipment. The maximum lift thickness will vary depending on the material and compaction equipment used but should generally not exceed 10 inches in loose thickness. We recommend that density testing of the placed structural fill be completed by a qualified geotechnical engineer to check that the structural fill compaction requirements presented in this report are achieved.

5.10.2. Area Fills and Bases

Fill placed to raise site grades and aggregate base materials under foundations and slabs should be placed on a prepared subgrade that consists of firm, inorganic native soils or compacted fill. Fill must be compacted to at least 95 percent of the MDD determined by ASTM Test Method D 1557 (modified Proctor). In pavement and crushed rock surfacing areas, the compaction criteria can be reduced to 92 percent below a depth of 2 feet from finished grade.

During wet weather or in areas that are particularly sensitive to subgrade disturbance, we recommend placing a woven geotextile between the subgrade and the first lift of fill. For this application, the first lift must comprise select granular fill. We recommend a 10-inch lift thickness and densification by static rolling for the initial lift.

5.10.3. Trench Backfill

Backfill in the bedding and pipe zone should be compacted to 90 percent of the MDD as determined by ASTM Test Method D 1557, or as recommended by the pipe manufacturer.

In nonstructural areas, trench backfill above the pipe zone should be compacted to at least 85 percent of the MDD as determined by ASTM Test Method D 1557. Suitable native soils or select granular soils should be acceptable in non-structural areas.

Within structural areas, trench backfill placed above the pipe zone must be compacted to at least 92 percent of the MDD as determined by ASTM Test Method D 1557 at depths greater than 2 feet below the finished subgrade, and to 95 percent within 2 feet of finished subgrade. Trench backfill in structural areas should consist of select granular fill or crushed rock as described in the previous sections.

5.11. Permanent Slopes

We recommend that permanent cut and fill slopes be inclined no steeper than 2H:1V. Flatter cut slopes may be necessary in areas where persistent groundwater seepage or zones of soft or loose soils are encountered.

To reduce the potential for erosion, newly constructed slopes should be planted or hydroseeded shortly after completion of grading. Some sloughing and raveling of the slopes should be expected until the vegetation is established. This may require localized repairs and reseeding. Temporary covering, such as heavy plastic sheeting, jute fabric, loose straw, or excelsior matting should be used to protect unvegetated slopes during periods of rainfall.

5.12. Foundation Support – At-Grade Structures

5.12.1. Shallow Foundations

Shallow foundations can be supported on undisturbed dense native ice contact/outwash soils following recompaction, or on a minimum 2-foot thickness of structural fill. Where dense native soils are encountered at footing subgrade, we recommend that the exposed surface be recompacted to a dense condition following excavation disturbance. If weather or subgrade conditions prevent adequate compaction, the subgrade should be overexcavated and replaced with a 2-foot thickness of structural fill. The structural fill pad should extend a minimum of 2 feet beyond the edges of the footing. Isolated column and continuous wall footings should have minimum widths of 24 and 18 inches, respectively.

The exterior footings should be embedded at least 18 inches below the lowest adjacent grade for frost protection. Interior footings can be founded a minimum of 12 inches below the top of the floor slab.

5.12.2. Bearing Capacity

We recommend that footings for the above-grade structures, founded as recommended be proportioned using an allowable bearing pressure of 3,000 psf. The recommended bearing pressures applies to the total of dead and long-term live loads and may be increased by one-third when considering earthquake or wind loads. This is a net bearing pressure. The weight of the footing and overlying backfill can be ignored in calculating footing sizes.

5.12.3. Footing Subgrade Preparation

Footing excavations should be performed using a smooth-edged bucket to limit bearing surface disturbance. Loose or disturbed materials present at the base of footing excavations should be removed or compacted. Foundation bearing surfaces should not be exposed to standing water. If water infiltrates and pools in the excavation, it must be removed, and the bearing surface reevaluated before placing structural fill or reinforcing steel.

We recommend that an experienced geotechnical engineer observe all foundation excavations before placing reinforcing steel in order to confirm that adequate bearing surfaces have been achieved and that the soil conditions are as anticipated. Unsuitable foundation subgrade soils must be removed and replaced with structural fill as recommended by the geotechnical engineer. It may be prudent to place a thin mud mat of lean concrete to protect the bearing surface if footing excavations are to remain open in wet weather.

5.12.4. Foundation Settlement

We estimate that settlements of footings designed and constructed as recommended will be less than $\frac{3}{4}$ inch, for the anticipated light loading conditions. Differential settlements between comparably loaded isolated column footings or along 50 feet of continuous footing should be less than $\frac{1}{2}$ inch. Settlement is expected to occur rapidly as loads are applied.

5.13. Slabs-On-Grade

We recommend floor slabs and on-grade supported facilities such as equipment slabs be supported on a minimum 18-inch thickness of structural fill. The upper 4 inches should consist of capillary break material, a well-graded sand and gravel or crushed rock that is a coarse-grained aggregate with negligible sand and silt (similar to American Association of State Highway and Transportation Officials [AASHTO] Grading No. 57). If adequate compaction of the native soils is not possible or if soft soils are encountered, the unsuitable subgrade soils should be over-excavated and replaced with compacted structural fill to a depth of 18 inches below the bottom of the slab. Structural fill placed below the slab, if necessary, should extend a minimum of 2 feet beyond the edge of the slab on all sides. Provided the slab foundations are constructed on the recommended subbase layer, the foundation performance can be evaluated using a subgrade modulus of 80 pounds per cubic inch (pci).

We recommend that a representative from our firm observe the excavation for crushed rock subbase, monitor the proofrolling or perform the hand probing to evaluate the condition of the exposed subgrade, monitor the compaction of structural fill and crushed rock, and recommend modifications if required.

We estimate that the post-construction settlement of on-grade slabs under static loading conditions may range from about $\frac{3}{4}$ to 1 inch provided that the slab subgrade is prepared as recommended. We expect that settlements for these conditions will tend to occur rapidly after the loads are applied.

5.14. Lateral Resistance

The ability of the soil to resist lateral loads is a function of frictional resistance, which can develop on the base of footings and slabs and the passive resistance, which can develop on the face of below-grade elements of the structure as these elements tend to move into the soil. For footings and floor slabs founded in accordance with the recommendations presented above, the allowable frictional resistance may be computed using a coefficient of friction of 0.35 applied to vertical dead-load forces. The allowable passive resistance on the face of footings, grade beams or other embedded foundation elements founded above the water table may be computed using an equivalent fluid density of 300 pounds per cubic foot (pcf) for undisturbed on-site soils or structural fill extending out from the face of the foundation element a distance at least equal to two and one-half times the depth of the element.

The passive earth pressure and friction components may be combined provided that the passive component does not exceed two-thirds of the total. The passive earth pressure value is based on the assumptions that the adjacent grade is level, and that groundwater remains below the base of the footing throughout the year. The top foot of soil should be neglected when calculating passive lateral earth pressures unless the foundation area is covered with pavement or is inside a building.

The lateral resistance values include a safety factor of approximately 1.5.

5.15. Below-Grade Structures

5.15.1. Lateral Earth Pressures

We recommend permanent below-grade walls be designed using a uniform lateral pressure of $35 \cdot H$ in psf above the water table, where H is the depth of the structure below a level ground surface to the groundwater elevation. For preliminary design, we recommend the long-term groundwater elevation be assumed to be as high as 5 feet below the existing ground surface. Below this depth, a uniform lateral pressure of $18 \cdot H$ psf can be utilized (assuming buoyant unit weight), and the design should account for hydrostatic head. The hydrostatic pressure should be added to the $18 \cdot H$ psf lateral pressure. In addition, we recommend a seismic loading be approximated using a uniform lateral pressure equal to $10 \cdot H$ psf, where H is the depth in feet below grade of the structure. This seismic lateral pressure is in addition to and should be superimposed upon the static soil and hydrostatic pressures.

These lateral soil pressures do not include traffic or other surcharges that should be added separately, if appropriate. For traffic loading, we recommend that below grade walls be designed for a uniform surcharge pressure determined by increasing the apparent height of the backfill around the wall by 2 feet (250 psf). Other surcharge loads should be included as appropriate.

The soil pressure available to resist lateral loads is a function of the passive resistance that can develop on the face of below-grade elements as those elements move horizontally into the soil. The allowable passive resistance on the face of embedded foundation elements may be computed using an equivalent fluid density of 170 pcf below the water table and 320 pcf above the water table. This passive equivalent fluid density value includes a factor of safety of about 1.5.

5.15.2. Buoyancy and Uplift

Below-grade structures will extend below the groundwater level and should be evaluated for buoyancy and uplift resistance. Resistance to uplift can be developed by the dead weight of the structure, friction along the sides of the structure, and the weight of zones of soil which are located above the base of the structure which protrude beyond the permanent walls. For design purposes, we recommend that hydrostatic uplift pressures be considered beginning at a depth of 5 feet below existing site grade. Frictional resistance can be computed using a coefficient of friction of 0.35 applied to the lateral soil pressures. This coefficient of friction value includes a factor of safety of about 1.5. We recommend that lateral soil pressures for uplift resistance be computed using an equivalent fluid density of 20 pcf considering groundwater is present. Backfill above the base of the structure may be assumed to have a submerged unit weight of 60 pcf.

5.15.3. Foundation Support

Subsurface soil conditions encountered near the base of the below-grade structures consists of dense outwash or very dense weathered Mashel Formation that will provide adequate support for the base slabs/footings.

The silty soils will become easily disturbed during excavation and when wet. To provide a level foundation pad and prevent disturbance, we recommend placing a minimum 12-inch-thick layer of crushed rock beneath the base of the structures. All loose soil should be removed from the subgrade prior to placing the crushed rock. We recommend that subgrade areas be evaluated by a geotechnical engineer immediately prior to placing the crushed rock to confirm that subsurface conditions are as expected and that the bearing surface has been prepared adequately. An allowable bearing pressure of 5,000 psf can be used in design of the proposed below-grade facilities founded below a depth of 10 feet.

5.16. Seismic Design Parameters

We recommend the use of the following 2018 International Building Code (IBC) parameters for seismic design:

TABLE 1. SEISMIC DESIGN PARAMETERS

2018 IBC (ASCE 7-16) Seismic Design Parameters	
Spectral Response Acceleration at Short Periods (S_s)	1.188g
Spectral Response Acceleration at 1-Second Periods (S_1)	0.424g
Site Class	D
Design Peak Ground Acceleration (PGA_M)	0.55g
Design Spectral Response Acceleration at Short Periods (S_{DS})	0.811g
Design Spectral Response Acceleration at 1-Second Periods (S_{D1})	null ¹

¹ A ground motion hazard analysis may be required in accordance with Section 11.4.8 of ASCE 7-16 unless Exception 2 is utilized in design.

5.17. Liquefaction Potential

Liquefaction refers to a condition where vibration or shaking of the ground, usually from earthquake forces, results in development of excess pore pressures in loose, saturated soils and subsequent loss of strength in the deposit of soil so affected. In general, soils that are susceptible to liquefaction include loose to medium dense “clean” to silty sands that are below the water table. Based on the conditions in our

explorations, there is the potential for some of the sand ice contact/outwash soils to experience liquefaction. However, based on the consistency of the outwash and depth to groundwater, it is our opinion the risk of liquefaction is low at the site.

6.0 LIMITATIONS

We have prepared this report for use by Robert W. Droll, Landscape Architects. This report may be made available to regulatory agencies. Our analysis, interpretations and conclusions should not be construed as a warranty of subsurface conditions beneath the site. We have relied on information prepared and supplied by others in developing our recommendations. GeoEngineers makes no representations as to the accuracy or reliability of these data.

Within the limitations of scope, schedule and budget, our services have been executed in accordance with generally accepted practices in the field of geotechnical engineering in this area at the time this report was prepared. The conclusions, recommendations, and opinions presented in this report are based on our professional knowledge, judgment and experience. No warranty or other conditions, express or implied, should be understood.

Please refer to Appendix C titled “Report Limitations and Guidelines for Use” for additional information pertaining to use of this report.



P:\2\2935067\GIS\2935067_Project.aprx\293506701_F01_VicinityMap_MRP Date Exported: 10/14/21 by ccaברה

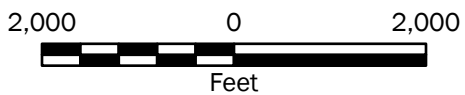
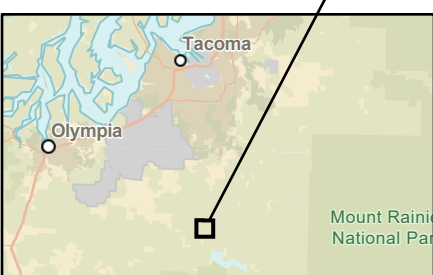

Vicinity Map

Nisqually State Park Proposed WWTP and SSL
Pierce County, Washington



Figure 1

Notes:

1. The locations of all features shown are approximate.
2. This drawing is for information purposes. It is intended to assist in showing features discussed in an attached document. GeoEngineers, Inc. cannot guarantee the accuracy and content of electronic files. The master file is stored by GeoEngineers, Inc. and will serve as the official record of this communication.

Data Source: ESRI

Projection: NAD 1983 StatePlane Washington North FIPS 4601 Feet

P:\2935067\CAD\01\Geotech Report - WWTP and SSL_293506701_F02_Site Plan.dwg TAB:F02 Date Exported: 10/14/21 - 13:48 by syj

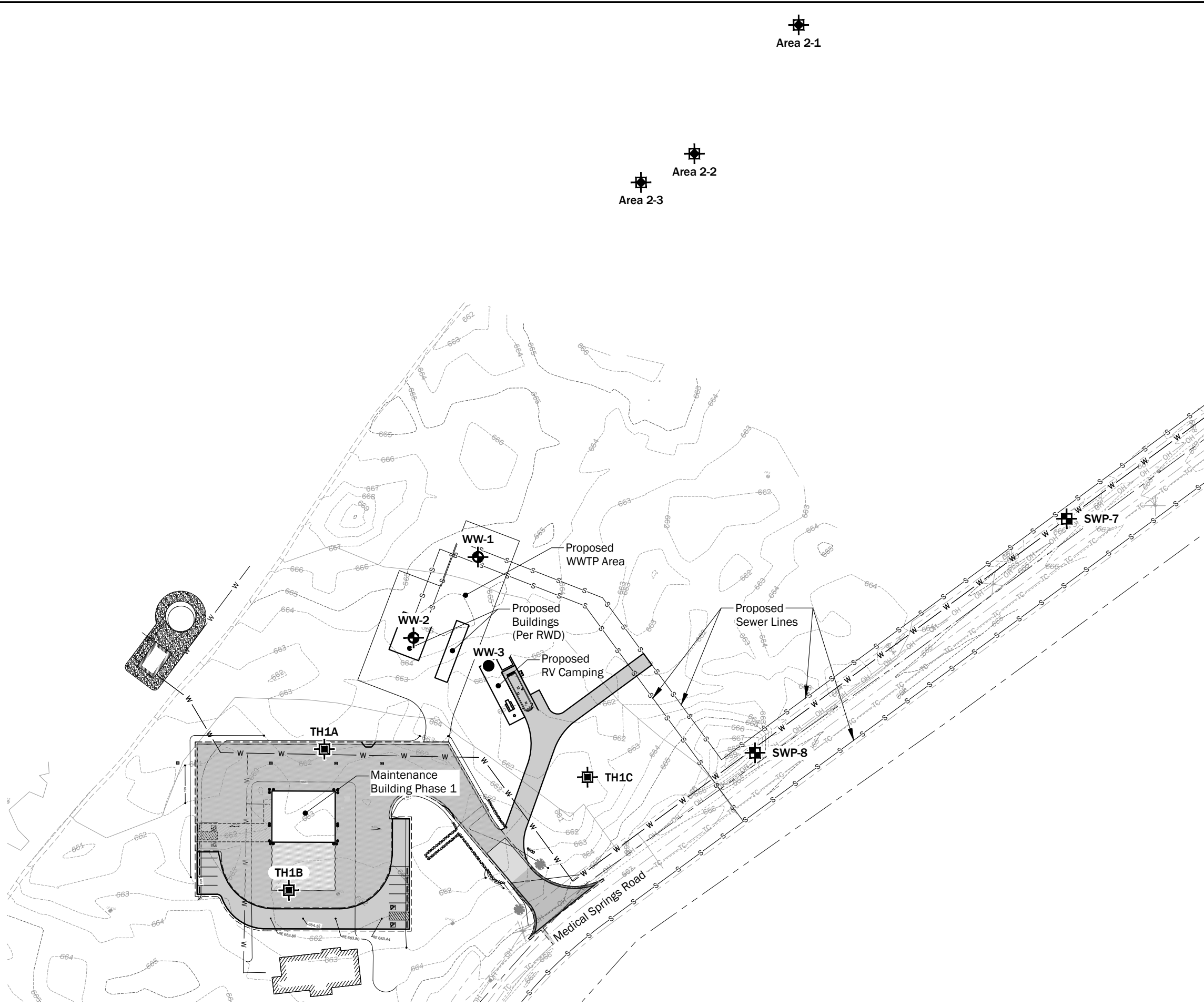

Area 2-1

Area 2-2

Area 2-3

Legend

- WW-1 Boring by GeoEngineers, Inc., 2021
- WW-3 Monitoring Well by GeoEngineers, Inc., 2021
- SWP-8 Test Pit by GeoEngineers, Inc., 2021
- Area 2-3 Test Pit by GeoEngineers, Inc. for Proposed Drainage Basin 2, 2021
- TH1A Test Pit by GeoEngineers, Inc. for Proposed Maintenance Building Area, 2020

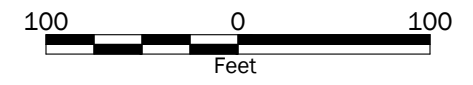
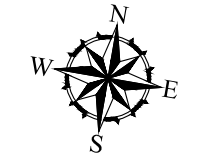

Notes:

1. The locations of all features shown are approximate.
2. This drawing is for information purposes. It is intended to assist in showing features discussed in an attached document. GeoEngineers, Inc. cannot guarantee the accuracy and content of electronic files. The master file is stored by GeoEngineers, Inc. and will serve as the official record of this communication.

Data Source: Background from RWD Landscape Architects, dated 09/07/21.

Vertical Datum: NAVD 88.

Projection: NAD83 Washington State Planes, South Zone, US Foot.

Site Plan	
Nisqually State Park, Proposed WWTP and SSL Pierce County, Washington	
	Figure 2

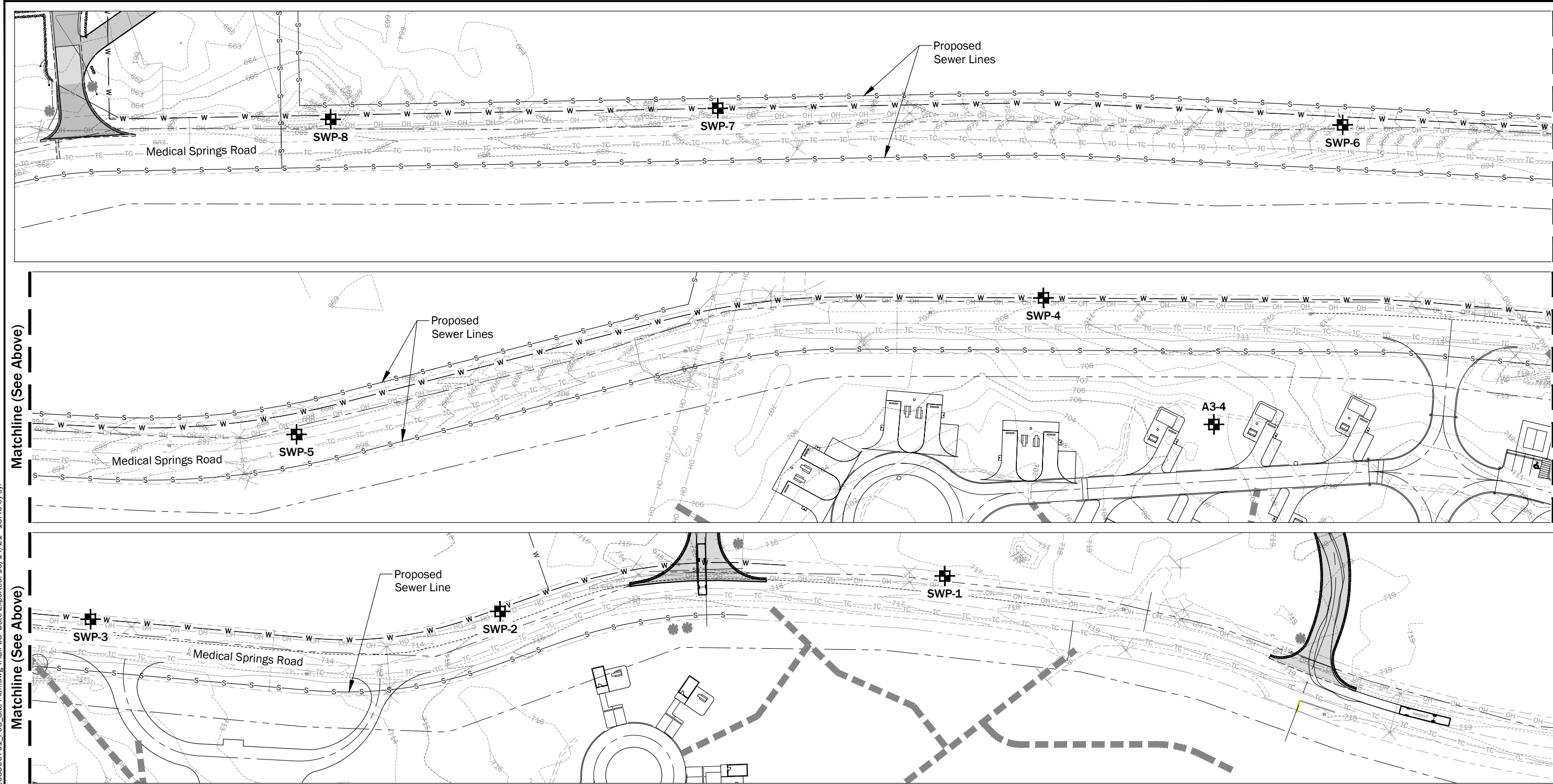

P:\2935067\CAD\01\Geotech Report - WWTP and SSL\293506701_F03_Site Plan.dwg TAB:F03 Date Exported: 10/14/21 - 13:49 by syf

Notes:

- The locations of all features shown are approximate.
- This drawing is for information purposes. It is intended to assist in showing features discussed in an attached document. GeoEngineers, Inc. cannot guarantee the accuracy and content of electronic files. The master file is stored by GeoEngineers, Inc. and will serve as the official record of this communication.

Data Source: Background from RWD Landscape Architects, dated 09/07/21.
 Vertical Datum: NAVD 88.
 Projection: NAD83 Washington State Planes, South Zone, US Foot.

Legend
 SWP-8 Test Pit by GeoEngineers, Inc., 2021

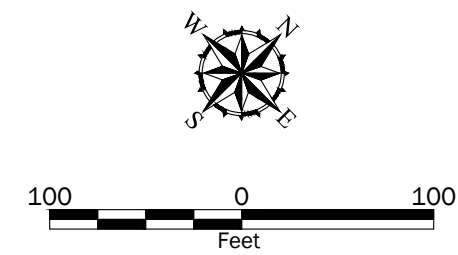

Site Plan	
Nisqually State Park, Proposed WWTP and SSL Pierce County, Washington	
	Figure 3

APPENDIX A
Field Explorations and Laboratory Testing

APPENDIX A FIELD EXPLORATIONS AND LABORATORY TESTING

Field Explorations

Soil and groundwater conditions were explored at the site by observing and collecting soil samples in three borings completed by Holocene Drilling, Inc. on September 23, 2021 and in eight test pits completed on July 9, 2021 by Kelly's Excavating, Inc. Explorations were completed to depths ranging from about 8 to about 31½ feet. Exploration locations should be considered approximate and are shown on Figures 2 and 3.

A monitoring well was constructed in boring WW-3 in general accordance with Washington State Department of Ecology (Ecology) regulations and covered with steel well monuments and caps. The well was developed by surging and pumping using a plastic submersible pump. This continued until relatively clear water was pumped from each well.

Our field representative obtained samples, classified the soils, maintained a detailed log of each exploration and observed groundwater conditions where applicable. Samples were collected on a continual basis from the sonic core barrel. Samples were also taken with a standard split spoon sampler at 5-foot intervals in general accordance with ASTM International (ASTM) D 1586. Samples from test pits were collected from the trackhoe bucket.

The samples were retained in sealed plastic bags. The soils were classified visually in general accordance with the system described in Figure A-1, which includes a key to the exploration logs. Summary logs of the explorations are included as Figures A-2 through A-12.

Laboratory Testing

Soil samples obtained from the explorations were brought to our laboratory to confirm field classifications. Selected samples were tested to determine their moisture content and grain-size distribution in general accordance with applicable ASTM standards.

The moisture content of selected samples was determined in general accordance with ASTM Test Method D 2216. The test results are presented in the respective exploration logs in Appendix A. Grain-size distribution (sieve analyses) testing was conducted in general accordance with ASTM Test Method D 422. The results of the grain-size and hydrometer analyses are presented in Figures A-13 and A-17.

SOIL CLASSIFICATION CHART

MAJOR DIVISIONS			SYMBOLS		TYPICAL DESCRIPTIONS
			GRAPH	LETTER	
COARSE GRAINED SOILS	GRAVEL AND GRAVELLY SOILS	CLEAN GRAVELS <small>(LITTLE OR NO FINES)</small>		GW	WELL-GRADED GRAVELS, GRAVEL - SAND MIXTURES
		GRAVELS WITH FINES <small>(APPRECIABLE AMOUNT OF FINES)</small>		GP	POORLY-GRADED GRAVELS, GRAVEL - SAND MIXTURES
		GRAVELS WITH FINES <small>(APPRECIABLE AMOUNT OF FINES)</small>		GM	SILTY GRAVELS, GRAVEL - SAND - SILT MIXTURES
	SAND AND SANDY SOILS	CLEAN SANDS <small>(LITTLE OR NO FINES)</small>		SW	WELL-GRADED SANDS, GRAVELLY SANDS
		SANDS WITH FINES <small>(APPRECIABLE AMOUNT OF FINES)</small>		SP	POORLY-GRADED SANDS, GRAVELLY SAND
		SANDS WITH FINES <small>(APPRECIABLE AMOUNT OF FINES)</small>		SM	SILTY SANDS, SAND - SILT MIXTURES
FINE GRAINED SOILS	SILTS AND CLAYS	LIQUID LIMIT LESS THAN 50		ML	INORGANIC SILTS, ROCK FLOUR, CLAYEY SILTS WITH SLIGHT PLASTICITY
		LIQUID LIMIT LESS THAN 50		CL	INORGANIC CLAYS OF LOW TO MEDIUM PLASTICITY, GRAVELLY CLAYS, SANDY CLAYS, SILTY CLAYS, LEAN CLAYS
		LIQUID LIMIT LESS THAN 50		OL	ORGANIC SILTS AND ORGANIC SILTY CLAYS OF LOW PLASTICITY
	SILTS AND CLAYS	LIQUID LIMIT GREATER THAN 50		MH	INORGANIC SILTS, MICACEOUS OR DIATOMACEOUS SILTY SOILS
		LIQUID LIMIT GREATER THAN 50		CH	INORGANIC CLAYS OF HIGH PLASTICITY
		LIQUID LIMIT GREATER THAN 50		OH	ORGANIC CLAYS AND SILTS OF MEDIUM TO HIGH PLASTICITY
HIGHLY ORGANIC SOILS			PT	PEAT, HUMUS, SWAMP SOILS WITH HIGH ORGANIC CONTENTS	

NOTE: Multiple symbols are used to indicate borderline or dual soil classifications

Sampler Symbol Descriptions

	2.4-inch I.D. split barrel
	Standard Penetration Test (SPT)
	Shelby tube
	Piston
	Direct-Push
	Bulk or grab
	Continuous Coring

Blowcount is recorded for driven samplers as the number of blows required to advance sampler 12 inches (or distance noted). See exploration log for hammer weight and drop.

"P" indicates sampler pushed using the weight of the drill rig.

"WOH" indicates sampler pushed using the weight of the hammer.

NOTE: The reader must refer to the discussion in the report text and the logs of explorations for a proper understanding of subsurface conditions. Descriptions on the logs apply only at the specific exploration locations and at the time the explorations were made; they are not warranted to be representative of subsurface conditions at other locations or times.

ADDITIONAL MATERIAL SYMBOLS

SYMBOLS		TYPICAL DESCRIPTIONS
GRAPH	LETTER	
	AC	Asphalt Concrete
	CC	Cement Concrete
	CR	Crushed Rock/Quarry Spalls
	SOD	Sod/Forest Duff
	TS	Topsoil

Groundwater Contact



Measured groundwater level in exploration, well, or piezometer



Measured free product in well or piezometer

Graphic Log Contact



Distinct contact between soil strata



Approximate contact between soil strata

Material Description Contact



Contact between geologic units



Contact between soil of the same geologic unit

Laboratory / Field Tests

%F	Percent fines
%G	Percent gravel
AL	Atterberg limits
CA	Chemical analysis
CP	Laboratory compaction test
CS	Consolidation test
DD	Dry density
DS	Direct shear
HA	Hydrometer analysis
MC	Moisture content
MD	Moisture content and dry density
Mohs	Mohs hardness scale
OC	Organic content
PM	Permeability or hydraulic conductivity
PI	Plasticity index
PL	Point load test
PP	Pocket penetrometer
SA	Sieve analysis
TX	Triaxial compression
UC	Unconfined compression
VS	Vane shear

Sheen Classification

NS	No Visible Sheen
SS	Slight Sheen
MS	Moderate Sheen
HS	Heavy Sheen

Key to Exploration Logs



Figure A-1

Start Drilled	9/23/2021	End	9/23/2021	Total Depth (ft)	31.5	Logged By	OA	Checked By		Driller	Holocene Drilling, Inc.	Drilling Method	Sonic
Surface Elevation (ft) Vertical Datum	665 NAVD88			Hammer Data	140 (lbs) / 30 (in) Drop			Drilling Equipment	GeoProbe 8140LC				
Latitude Longitude	46.8558 -122.34188			System Datum	WA State Plane South NAD83 (feet)			See "Remarks" section for groundwater observed					
Notes:													

Elevation (feet)	FIELD DATA					Graphic Log	Group Classification	MATERIAL DESCRIPTION	Moisture Content (%)	Fines Content (%)	REMARKS
	Depth (feet)	Interval Recovered (in)	Blows/foot	Collected Sample	Sample Name Testing						
0						DUF	Forest duff				
5	7	33		1	SM	Tan fine silty sand with gravel (dense, moist) (outwash/ice contact)		4	15		
10		80/6"		2	GM	Gray silty gravel with sand (very dense, moist) (outwash/ice contact)		6	21	(Density likely due to gravel)	
15	5	50/6"		4	GM	Tan-brown fine to coarse silty sand with gravel (very dense, wet) (outwash/ice contact)		8	15	Broken SPT sampler, possibly due to boulder	Groundwater observed at approximately 12 feet at time of drilling
20	18	53		6	GM	Dark gray silty gravel with sand (very dense, moist) (outwash/ice contact)		15	29		
25	18	70/6"		7	ML	Dark gray sandy silt (hard, moist) (Mashel Formation)		31	56		
30	18	34		10A	SM	Dark gray silty sand (very dense, moist) (Mashel Formation)					
				10B							
				11	ML	Dark gray silt with sand (Mashel Formation)		30	79		
				12 SA							

Note: See Figure A-1 for explanation of symbols.
Coordinates Data Source: Horizontal approximated based on Topographic Survey. Vertical approximated based on Topographic Survey.

Log of Boring WW-1



Project: Nisqually State Park, Proposed WWTP and SSL
Project Location: Pierce County, Washington
Project Number: 2935-067-01

Date: 10/14/21 Path: \\GEOENGINEERS\COM\WAN\PROJECTS\2_2935067\GINT\293506701.GPJ DBLibrary\Library\GEOENGINEERS_DF_STD_US_JUNE_2017.GLB\GEB_GEO TECH_STANDARD_MF_NO_GW

Start Drilled	9/23/2021	End	9/23/2021	Total Depth (ft)	31.5	Logged By	OA	Checked By		Driller	Holocene Drilling, Inc.	Drilling Method	Sonic
Surface Elevation (ft) Vertical Datum	665 NAVD88			Hammer Data	140 (lbs) / 30 (in) Drop			Drilling Equipment	GeoProbe 8140LC				
Latitude	46.85555			System Datum	WA State Plane South NAD83 (feet)			See "Remarks" section for groundwater observed					
Longitude	-122.34206												
Notes:													

Elevation (feet)	Depth (feet)	FIELD DATA				Graphic Log	Group Classification	MATERIAL DESCRIPTION	Moisture Content (%)	Fines Content (%)	REMARKS
		Interval Recovered (in)	Blows/foot	Collected Sample	Sample Name Testing						
0	0					DUF	Forest duff				
	1				1	SM	Tan silty fine to medium sand with occasional gravel, cobbles and boulders (loose, moist) (outwash/ice contact)				
660	5	1	50/2"		2		Grades to very dense			Rock in shoe; very slow drilling from 5 to 10 feet below the ground surface	
	10	2	50/2"		3	GM	Gray gravel with sand, cobbles and boulders (very dense, moist) (outwash/ice contact)	4	21	Boulders shifted drill alignment	
655	15	5	50/1"		4			11	19	Drilled through rock	
650	20	18	70/6"		6					Groundwater observed at approximately 14 feet during drilling	
	25	18	55		7	SM	Brown silty fine sand with oxidation staining (very dense, moist to wet) (Mashel Formation)	9	22		
645	30				8	SM	Dark gray silty sand (very dense, moist) (Mashel Formation)	30	40	Very difficult drilling	
640					9 & 10						
	30				11						
					12	SP-SM	Gray sand with silt and occasional gravel (very dense, wet) (Mashel Formation)	12	8		
635					13						

Note: See Figure A-1 for explanation of symbols.
Coordinates Data Source: Horizontal approximated based on Topographic Survey. Vertical approximated based on Topographic Survey.

Log of Boring WW-2



Project: Nisqually State Park, Proposed WWTP and SSL
Project Location: Pierce County, Washington
Project Number: 2935-067-01

Date: 10/14/21 Path: \\GEOENGINEERS\COM\WAW\PROJECTS\2_2935067\GINT\2935067-01.GPJ DBLibrary\Library\GEOENGINEERS_DF_STD_US_JUNE_2017.GLB\GEB_GEO TECH_STANDARD_%F_NO_GW

Start Drilled 9/23/2021	End 9/23/2021	Total Depth (ft)	31.5	Logged By Checked By	OA	Driller Holocene Drilling, Inc.	Drilling Method	Sonic
Hammer Data		140 (lbs) / 30 (in) Drop		Drilling Equipment		GeoProbe 8140LC		DOE Well I.D.: BNG 443 A 2-in well was installed on 9/23/2021 to a depth of 31.5 ft.
Surface Elevation (ft) Vertical Datum		664 NAVD88		Top of Casing Elevation (ft)		Groundwater Date Measured		
Latitude Longitude		46.85552 -122.34175		Horizontal Datum		WA State Plane South NAD83 (feet)		Depth to Water (ft) Elevation (ft)
						10/7/2021		11.53 653
Notes:								

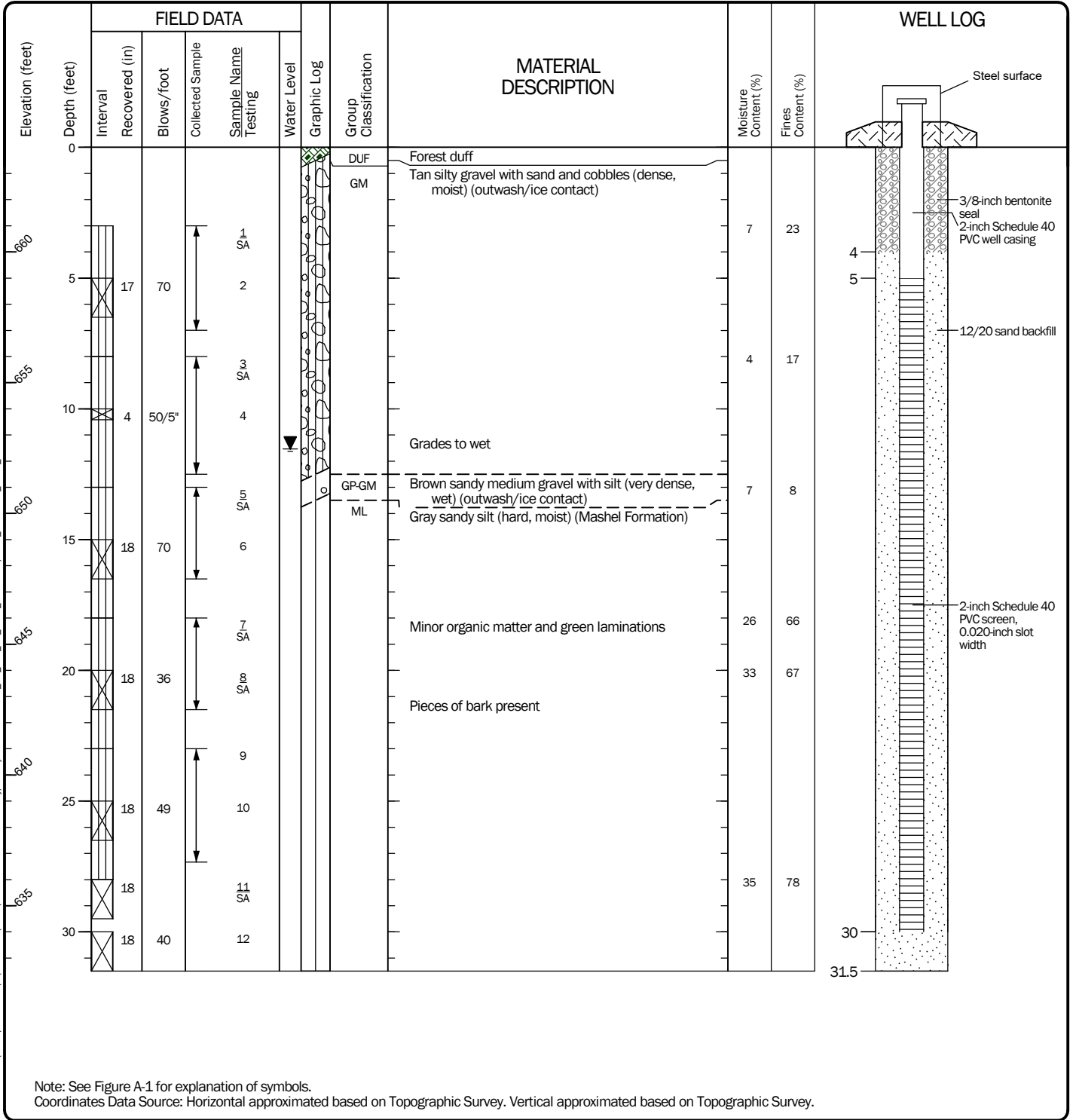

Note: See Figure A-1 for explanation of symbols.
Coordinates Data Source: Horizontal approximated based on Topographic Survey. Vertical approximated based on Topographic Survey.

Log of Monitoring Well WW-3



Project: Nisqually State Park, Proposed WWTP and SSL
Project Location: Pierce County, Washington
Project Number: 2935-067-01

Date: 10/14/21 Path: \\GEOENGINEERS.COM\WAN\PROJECTS\2935067\GINT\293506701.GPJ DBLibrary\Library\GEOENGINEERS_DF_STD_US_JUNE_2017.GLB\GEB_GEO TECH_WELL_MF

Date Excavated	7/8/2021	Total Depth (ft)	8	Logged By	CJL	Excavator	Kelly's Excavating, Inc.	Groundwater not observed
				Checked By	SWH	Equipment	Takeuchi TB 138 Mini Excavator	See "Remarks" section for caving observed
Surface Elevation (ft) Vertical Datum	717 NAVD88	Latitude Longitude	46.86294 -122.331	Coordinate System Horizontal Datum	WA State Plane South NAD83 (feet)			

Elevation (feet)	Depth (feet)	SAMPLE		Graphic Log	Group Classification	MATERIAL DESCRIPTION	Moisture Content (%)	Fines Content (%)	REMARKS
		Testing Sample	Sample Name Testing						
716	1				DUFF	4 inches of forest duff			
715	2		1 SA		GP-GM	Brown fine to coarse gravel with silt, sand and cobbles (medium dense, moist) (outwash)	5	9	Severe caving from 2 to 8 feet
714	3				GP	Brown-gray fine to coarse gravel with sand and cobbles (loose, moist) (outwash)			
712	5		2			Grades to gray with occasional boulders			
711	6								
710	7								
709	8								

Notes: See Figure A-1 for explanation of symbols.
The depths on the test pit logs are based on an average of measurements across the test pit and should be considered accurate to 1/2 foot.
Coordinates Data Source: Horizontal approximated based on Topographic Survey. Vertical approximated based on Topographic Survey.

Log of Test Pit SWP-1



Project: Nisqually State Park, Proposed WWTP and SSL
Project Location: Pierce County, Washington
Project Number: 2935-067-01

Figure A-5
Sheet 1 of 1

Date: 10/14/21 Path: \\GEOENGINEERS.COM\WAN\PROJECTS\2_2935067\GINT\2935067\01.GPJ DBLibrary/Library\GEOENGINEERS_DF_STD_US_JUNE_2017.GLB\GER_TESTPIT_AP_GEOTEC_%F

Date Excavated	7/8/2021	Total Depth (ft)	8	Logged By	CJL	Excavator	Kelly's Excavating, Inc.	Groundwater not observed
				Checked By	SWH	Equipment	Takeuchi TB 138 Mini Excavator	See "Remarks" section for caving observed
Surface Elevation (ft)	715	Latitude	46.86199	Coordinate System	Horizontal Datum	WA State Plane South NAD83 (feet)		
Vertical Datum	NAVD88	Longitude	-122.33212					

Elevation (feet)	Depth (feet)	SAMPLE		Graphic Log	Group Classification	MATERIAL DESCRIPTION	Moisture Content (%)	Fines Content (%)	REMARKS
		Testing Sample	Sample Name Testing						
714	1				DUFF	6 inches of forest duff			
713	2		1		GP-GM	Brown fine to coarse gravel with silt, sand and cobbles (medium dense, moist) (outwash)			
711	4				GP	Gray fine to coarse gravel with sand, cobbles and occasional boulders (medium dense, moist) (outwash)			Moderate caving from 4 to 8 feet
710	5		2 SA				3	2	
709	6								
708	7								
707	8								

Date: 10/14/21 Path: \\GEOENGINEERS.COM\WAN\PROJECTS\2_2935067\GINT\2935067-01.GPJ DBLibrary/Library\GEOENGINEERS_DF_STD_US_JUNE_2017.GLB\GER_TESTPIT_AP_GEOTEC.%.F

Notes: See Figure A-1 for explanation of symbols.
 The depths on the test pit logs are based on an average of measurements across the test pit and should be considered accurate to 1/2 foot.
 Coordinates Data Source: Horizontal approximated based on Topographic Survey. Vertical approximated based on Topographic Survey.

Log of Test Pit SWP-2		
	Project: Nisqually State Park, Proposed WWTP and SSL	Figure A-6 Sheet 1 of 1
	Project Location: Pierce County, Washington	
	Project Number: 2935-067-01	

Date Excavated	7/8/2021	Total Depth (ft)	9.5	Logged By	CJL	Excavator	Kelly's Excavating, Inc.	Groundwater not observed
				Checked By	SWH	Equipment	Takeuchi TB 138 Mini Excavator	See "Remarks" section for caving observed
Surface Elevation (ft) Vertical Datum	713 NAVD88		Latitude Longitude	46.86117 -122.33322		Coordinate System Horizontal Datum	WA State Plane South NAD83 (feet)	

Elevation (feet)	Depth (feet)	SAMPLE		Graphic Log	Group Classification	MATERIAL DESCRIPTION	Moisture Content (%)	Fines Content (%)	REMARKS
		Testing Sample	Sample Name Testing						
712	1				DUFF	6 inches of forest duff			
711	2				GP-GM	Brown fine to coarse gravel with silt, sand and cobbles (medium dense, moist) (outwash)			
710	3		S _A 1				4	11	
708	4		S _A 2						
708	5				GW	Brown-gray fine to coarse gravel with sand, cobbles and occasional boulders (medium dense, moist) (outwash)	3	5	Moderate caving from 4 to 9½ feet
707	6								
706	7								
705	8								
704	9		3						

Date: 10/14/21 Path: \\GEOENGINEERS.COM\WAN\PROJECTS\2_2935067\GINT\2935067\GIB\TESTPIT_3P_GEOTECH.F

Notes: See Figure A-1 for explanation of symbols.
 The depths on the test pit logs are based on an average of measurements across the test pit and should be considered accurate to ½ foot.
 Coordinates Data Source: Horizontal approximated based on Topographic Survey. Vertical approximated based on Topographic Survey.

Log of Test Pit SWP-3		
	Project:	Nisqually State Park, Proposed WWTP and SSL
	Project Location:	Pierce County, Washington
	Project Number:	2935-067-01
		Figure A-7 Sheet 1 of 1

Date Excavated	7/8/2021	Total Depth (ft)	9	Logged By	CJL	Excavator	Kelly's Excavating, Inc.	Groundwater not observed
				Checked By	SWH	Equipment	Takeuchi TB 138 Mini Excavator	See "Remarks" section for caving observed
Surface Elevation (ft)	708	Latitude	46.86008	Coordinate System	WA State Plane South			
Vertical Datum	NAVD88	Longitude	-122.33485	Horizontal Datum	NAD83 (feet)			

Elevation (feet)	Depth (feet)	SAMPLE		Graphic Log	Group Classification	MATERIAL DESCRIPTION	Moisture Content (%)	Fines Content (%)	REMARKS
		Testing Sample	Sample Name Testing						
707	1				DUFF	6 inches of forest duff			Moderate caving from 1 to 6 feet
706	2				SP-SM	Brown-gray fine to medium sand with silt, gravel and cobbles (loose to medium dense, moist) (outwash)			
705	3	1	SA				4	6	
704	4				GP	Gray fine to coarse gravel with sand and cobbles (medium dense, moist) (outwash)			
703	5								
702	6	2							
701	7								
700	8								
699	9								

Date: 10/14/21 Path: \\GEOENGINEERS.COM\WAN\PROJECTS\2_2935067\GINT\2935067-01.GPJ DBLibrary/Library\GEOENGINEERS_DF_STD_US_JUNE_2017.GLB\GER_TESTPIT_AP_GEOTEC_%F









Notes: See Figure A-1 for explanation of symbols.
 The depths on the test pit logs are based on an average of measurements across the test pit and should be considered accurate to 1/2 foot.
 Coordinates Data Source: Horizontal approximated based on Topographic Survey. Vertical approximated based on Topographic Survey.

Log of Test Pit SWP-4



Project: Nisqually State Park, Proposed WWTP and SSL
 Project Location: Pierce County, Washington
 Project Number: 2935-067-01

Date Excavated	7/8/2021	Total Depth (ft)	8	Logged By	CJL	Excavator	Kelly's Excavating, Inc.	Groundwater not observed
				Checked By	SWH	Equipment	Takeuchi TB 138 Mini Excavator	See "Remarks" section for caving observed
Surface Elevation (ft) Vertical Datum	698 NAVD88	Latitude Longitude	46.85834 -122.3365	Coordinate System Horizontal Datum	WA State Plane South NAD83 (feet)			

Elevation (feet)	Depth (feet)	SAMPLE		Graphic Log	Group Classification	MATERIAL DESCRIPTION	Moisture Content (%)	Fines Content (%)	REMARKS
		Testing Sample	Sample Name Testing						
697	1				DUFF	6 inches of forest duff			Moderate caving from 1 to 8 feet
696	2				GP	Brown fine to coarse gravel with sand and cobbles (medium dense, moist) (outwash)			
695	3					Grades to gray			
694	4		1						
693	5								
692	6								
691	7								
690	8								

Notes: See Figure A-1 for explanation of symbols.
The depths on the test pit logs are based on an average of measurements across the test pit and should be considered accurate to 1/2 foot.
Coordinates Data Source: Horizontal approximated based on Topographic Survey. Vertical approximated based on Topographic Survey.

Log of Test Pit SWP-5



Project: Nisqually State Park, Proposed WWTP and SSL
Project Location: Pierce County, Washington
Project Number: 2935-067-01

Figure A-9
Sheet 1 of 1

Date: 10/14/21 Path: \\GEOENGINEERS.COM\WAN\PROJECTS\2_2935067\GINT\2935067-01.GPJ DBLibrary/Library\GEOENGINEERS_DF_STD_US_JUNE_2017.GLB\GER_TESTPIT_AP_GEOTEC_%F

Date Excavated	7/8/2021	Total Depth (ft)	8.5	Logged By	CJL	Excavator	Kelly's Excavating, Inc.	Groundwater not observed
				Checked By	SWH	Equipment	Takeuchi TB 138 Mini Excavator	See "Remarks" section for caving observed
Surface Elevation (ft)	686	Latitude	46.85742	Coordinate System	Horizontal Datum	WA State Plane South NAD83 (feet)		
Vertical Datum	NAVD88	Longitude	-122.33786					

Elevation (feet)	Depth (feet)	SAMPLE		Group Classification	MATERIAL DESCRIPTION	Moisture Content (%)	Fines Content (%)	REMARKS
		Testing Sample	Sample Name Testing					
685	1			DUFF	6 inches of forest duff			Moderate caving from 1 to 8½ feet
684	2			GP-GM	Red-brown fine to coarse gravel with silt, sand, cobbles and occasional boulders (loose to medium dense, moist)			
683	3	1	SA			4	7	
682	4			GP	Gray fine to coarse gravel with sand, cobbles and occasional boulders (medium dense, moist)			
681	5			SP	Gray fine to coarse sand with gravel and occasional cobbles (medium dense, moist)			
680	6	2	SA			5	1	
679	7			GP	Gray fine to coarse gravel with sand, cobbles and occasional boulders (dense, moist)			
678	8	3						

Date: 10/14/21 Path: \\GEOENGINEERS.COM\WAN\PROJECTS\2_2935067\GINT\2935067-01.GPJ DBLibrary/Library\GEOENGINEERS_DF_STD_US_JUNE_2017.GLB\GER_TESTPIT_IP_GEOTEC.MF

Notes: See Figure A-1 for explanation of symbols.
 The depths on the test pit logs are based on an average of measurements across the test pit and should be considered accurate to ½ foot.
 Coordinates Data Source: Horizontal approximated based on Topographic Survey. Vertical approximated based on Topographic Survey.

Log of Test Pit SWP-6



Project: Nisqually State Park, Proposed WWTP and SSL
 Project Location: Pierce County, Washington
 Project Number: 2935-067-01

Date Excavated	7/8/2021	Total Depth (ft)	9	Logged By	CJL	Excavator	Kelly's Excavating, Inc.	Groundwater not observed
				Checked By	SWH	Equipment	Takeuchi TB 138 Mini Excavator	Caving not observed
Surface Elevation (ft)	666	Latitude	46.85621	Coordinate System	WA State Plane South			
Vertical Datum	NAVD88	Longitude	-122.33962	Horizontal Datum	NAD83 (feet)			

Elevation (feet)	Depth (feet)	SAMPLE		Graphic Log	Group Classification	MATERIAL DESCRIPTION	Moisture Content (%)	Fines Content (%)	REMARKS
		Testing Sample	Sample Name Testing						
665	1				DUFF	6 inches of forest duff			
664	2		SA		GP-GM	Brown gravel with silt and sand and cobbles (medium dense, moist)	5	10	
663	3								
662	4								
661	5		2		GP-GM	Gray gravel with sand, silt and occasional cobbles (medium dense, moist)			
660	6								
659	7					Grades to with iron-oxide staining and occasional gravel			
658	8								
657	9		3			Grades to with gravel, cobbles and occasional boulders	11	12	

Date: 10/14/21 Path: \\GEOENGINEERS.COM\WAN\PROJECTS\2_2935067\GINT\2935067-01.GPJ DBLibrary/Library\GEOENGINEERS_DF_STD_US_JUNE_2017.GLB\GER_TESTPIT_IP_GEOTEC.%F

Notes: See Figure A-1 for explanation of symbols.
 The depths on the test pit logs are based on an average of measurements across the test pit and should be considered accurate to 1/2 foot.
 Coordinates Data Source: Horizontal approximated based on Topographic Survey. Vertical approximated based on Topographic Survey.

Log of Test Pit SWP-7



Project: Nisqually State Park, Proposed WWTP and SSL
 Project Location: Pierce County, Washington
 Project Number: 2935-067-01

Date Excavated	7/8/2021	Total Depth (ft)	6	Logged By	CJL	Excavator	Kelly's Excavating, Inc.	Groundwater not observed
				Checked By	SWH	Equipment	Takeuchi TB 138 Mini Excavator	See "Remarks" section for caving observed
Surface Elevation (ft)	667	Latitude	46.85543	Coordinate System	Horizontal Datum	WA State Plane South NAD83 (feet)		
Vertical Datum	NAVD88	Longitude	-122.34065					

Elevation (feet)	Depth (feet)	SAMPLE		Graphic Log	Group Classification	MATERIAL DESCRIPTION	Moisture Content (%)	Fines Content (%)	REMARKS
		Testing Sample	Sample Name Testing						
666	1				DUFF	4 inches of forest duff			Moderate caving from 0 to 6 feet
665	2		§1		GP-GM	Brown fine to coarse gravel with silt, sand, cobbles and boulders (medium dense, moist)	6	11	
664	3				GP	Gray fine to coarse gravel with sand, cobbles and boulders (medium dense, moist)			
663	4				GP	Gray fine to coarse gravel with sand, cobbles and boulders (medium dense, moist)			
662	5				GP	Grades to dense			
661	6		2		GP	Grades to dense			

Date: 10/14/21 Path: \\GEOENGINEERS.COM\WAN\PROJECTS\2_2935067\GINT\2935067-01.GPJ DBLibrary/Library\GEOENGINEERS_DF_STD_US_JUNE_2017.GLB\GER_TESTPIT_AP_GEOTEC_%F

Notes: See Figure A-1 for explanation of symbols.
 The depths on the test pit logs are based on an average of measurements across the test pit and should be considered accurate to 1/2 foot.
 Coordinates Data Source: Horizontal approximated based on Topographic Survey. Vertical approximated based on Topographic Survey.

Log of Test Pit SWP-8



Project: Nisqually State Park, Proposed WWTP and SSL
 Project Location: Pierce County, Washington
 Project Number: 2935-067-01

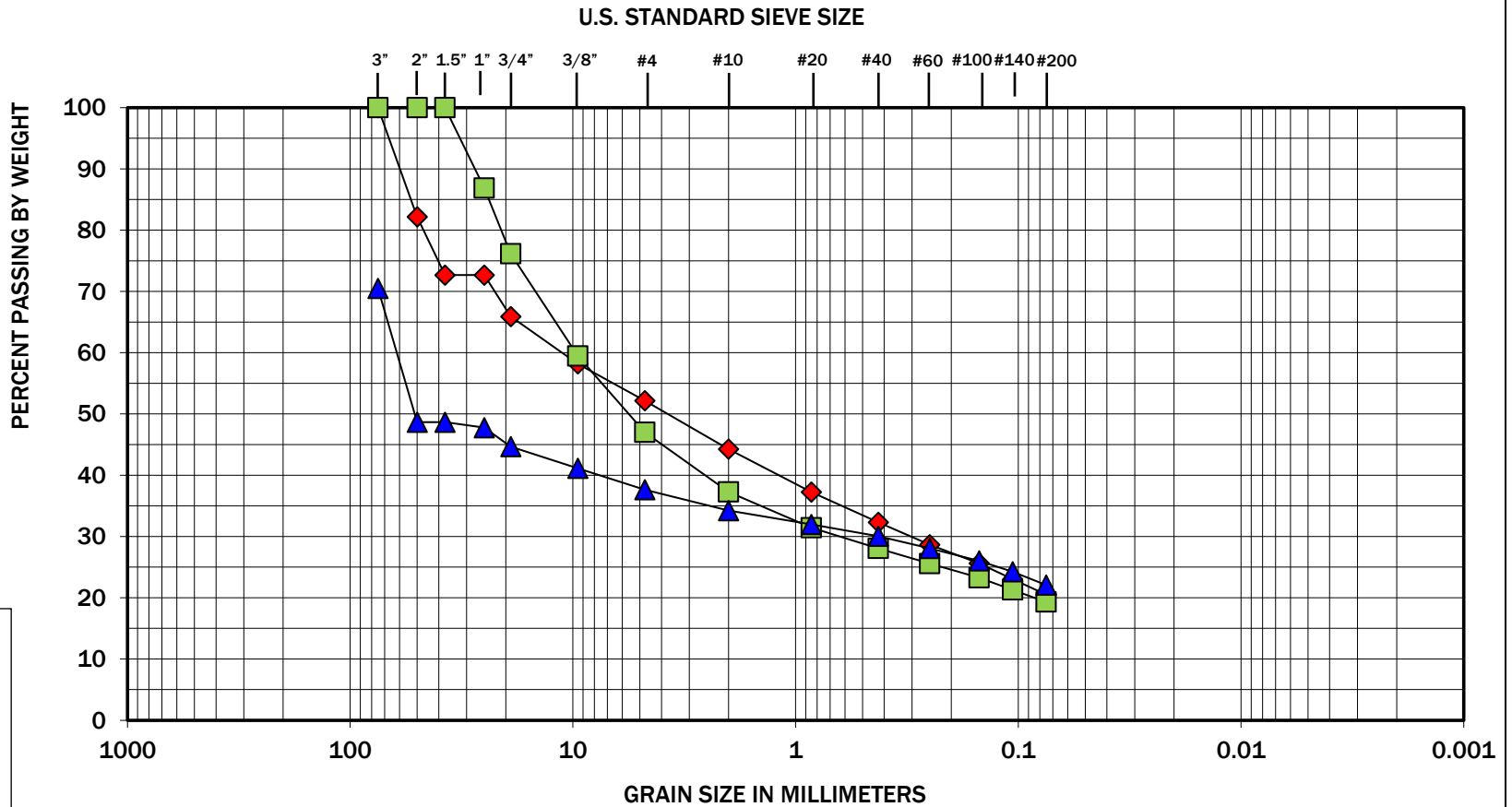

COBBLES	GRAVEL		SAND			SILT OR CLAY
	COARSE	FINE	COARSE	MEDIUM	FINE	

Symbol	Boring Number	Depth (feet)	Moisture (%)	Soil Description
◆	WW-2	8	4	Silty gravel with sand (GM)
■	WW-2	13	11	Silty gravel with sand (GM)
▲	WW-2	18	9	Silty gravel with sand (GM)



Note: This report may not be reproduced, except in full, without written approval of GeoEngineers, Inc. Test results are applicable only to the specific sample on which they were performed, and should not be interpreted as representative of any other samples obtained at other times, depths or locations, or generated by separate operations or processes.

The grain size analysis results were obtained in general accordance with ASTM C 136. GeoEngineers 17425 NE Union Hill Road Ste 250, Redmond, WA 98052

GEOENGINEERS



Figure A-14

Nisqually State Park, MRP Plant and Sewer Line
Pierce County, Washington

Sieve Analysis Results

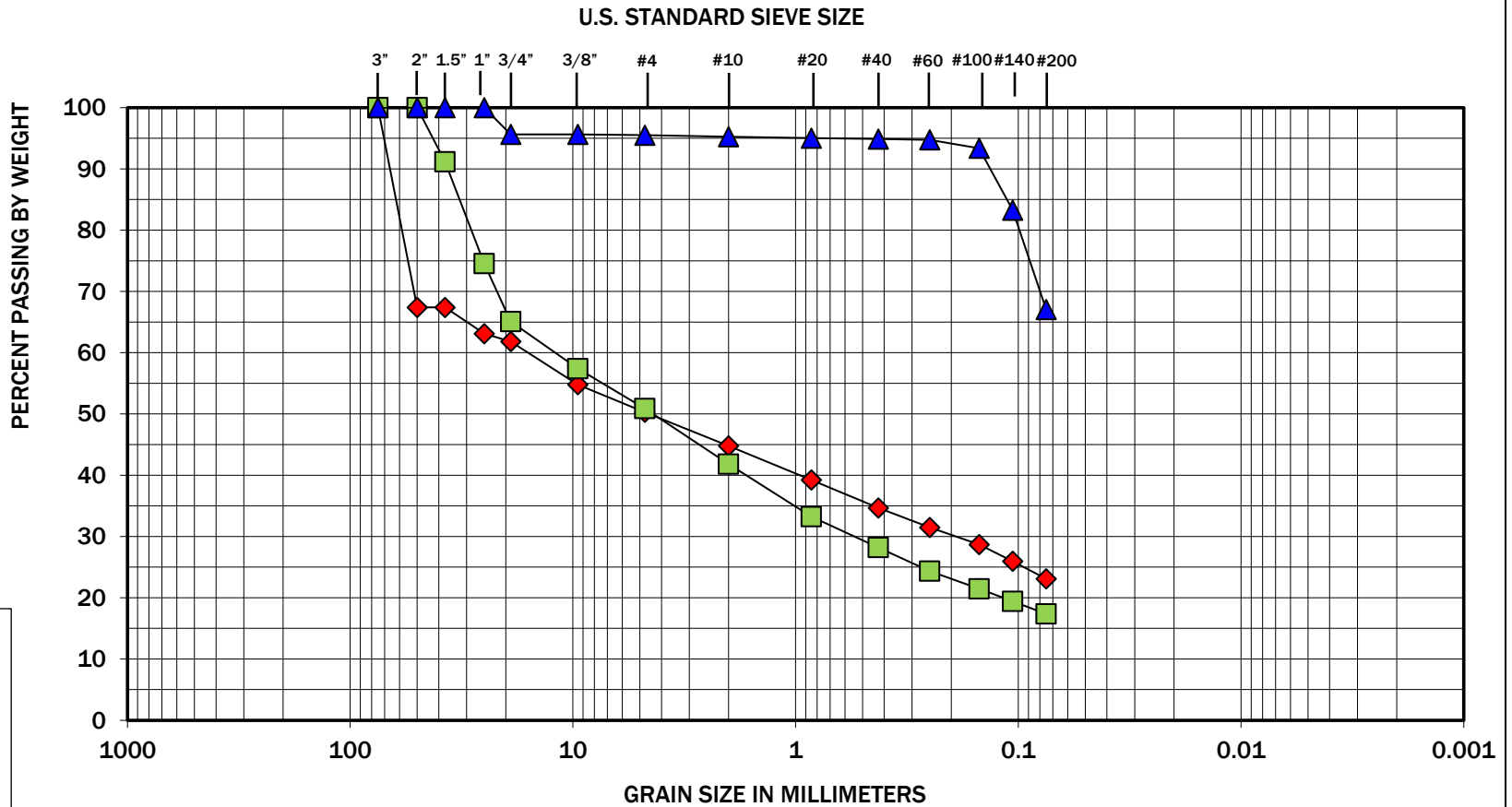

COBBLES	GRAVEL		SAND			SILT OR CLAY
	COARSE	FINE	COARSE	MEDIUM	FINE	

Symbol	Boring Number	Depth (feet)	Moisture (%)	Soil Description
◆	WW-3	3	7	Silty gravel with sand (GM)
■	WW-3	8	4	Silty gravel with sand (GM)
▲	WW-3	20	33	Sandy silt (ML)



Note: This report may not be reproduced, except in full, without written approval of GeoEngineers, Inc. Test results are applicable only to the specific sample on which they were performed, and should not be interpreted as representative of any other samples obtained at other times, depths or locations, or generated by separate operations or processes.

The grain size analysis results were obtained in general accordance with ASTM C 136. GeoEngineers 17425 NE Union Hill Road Ste 250, Redmond, WA 98052

GEOENGINEERS

Figure A-15

Nisqually State Park, MRP Plant and Sewer Line
Pierce County, Washington

Sieve Analysis Results

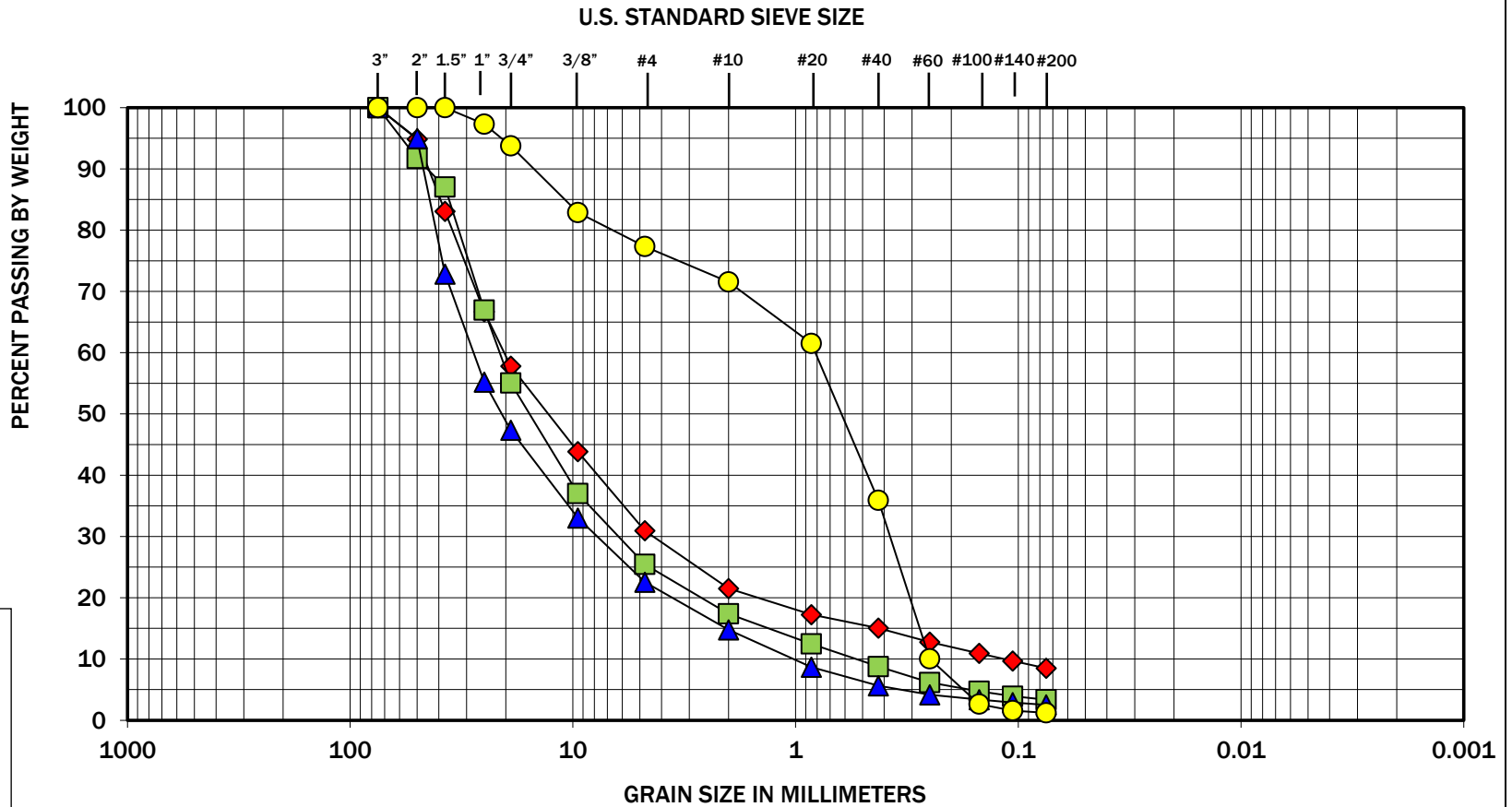

Symbol	Boring Number	Depth (feet)	Moisture (%)	Soil Description
◆	SWP-1	2	5	Poorly graded gravel with silt and sand (GP-GM)
■	SWP-2	5.5	3	Poorly graded gravel with sand (GP)
▲	SWP-3	4	3	Well-graded gravel with sand (GW)
●	SWP-6	5.5	5	Poorly graded sand with gravel (SP)



Note: This report may not be reproduced, except in full, without written approval of GeoEngineers, Inc. Test results are applicable only to the specific sample on which they were performed, and should not be interpreted as representative of any other samples obtained at other times, depths or locations, or generated by separate operations or processes.

The grain size analysis results were obtained in general accordance with ASTM C 136. GeoEngineers 17425 NE Union Hill Road Ste 250, Redmond, WA 98052

GEOENGINEERS

Figure A-16

Nisqually State Park, MRP Plant and Sewer Line
Pierce County, Washington

Sieve Analysis Results

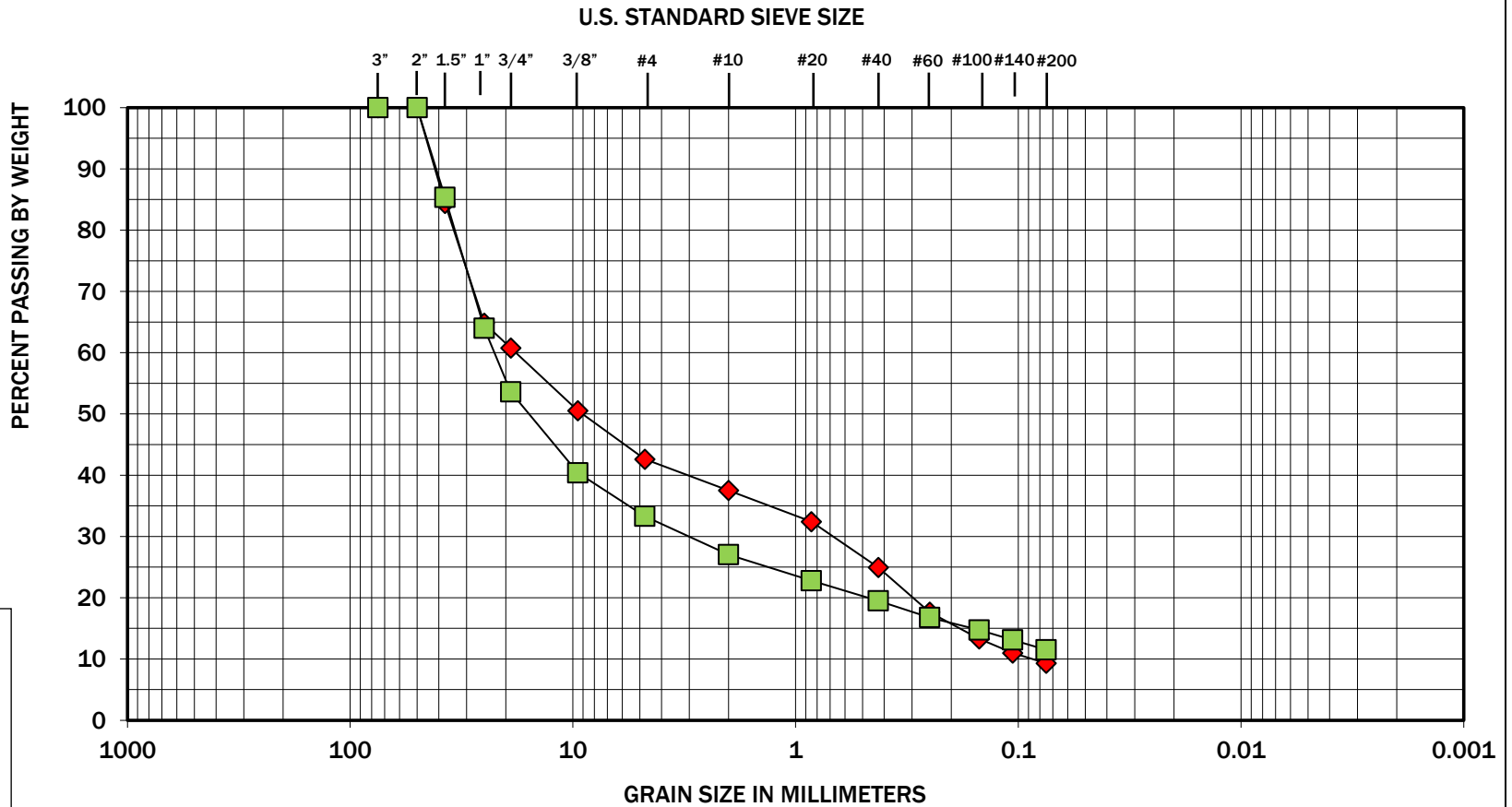

COBBLES	GRAVEL		SAND			SILT OR CLAY
	COARSE	FINE	COARSE	MEDIUM	FINE	

Symbol	Boring Number	Depth (feet)	Moisture (%)	Soil Description
◆	SWP-7	2	5	Poorly graded gravel with silt and sand (GP-GM)
■	SWP-8	1.5	6	Poorly graded gravel with silt and sand (GP-GM)



Note: This report may not be reproduced, except in full, without written approval of GeoEngineers, Inc. Test results are applicable only to the specific sample on which they were performed, and should not be interpreted as representative of any other samples obtained at other times, depths or locations, or generated by separate operations or processes.

The grain size analysis results were obtained in general accordance with ASTM C 136. GeoEngineers 17425 NE Union Hill Road Ste 250, Redmond, WA 98052

GEOENGINEERS



Figure A-17

Nisqually State Park, MRP Plant and Sewer Line
Pierce County, Washington

Sieve Analysis Results

APPENDIX B
Proposed Maintenance Building and
Drainage Basin 2 Test Pit Logs

Date Excavated	12/1/2020	Total Depth (ft)	10	Logged By	SLG	Excavator	Kelly's Excavating	See "Remarks" section for groundwater observed Caving not observed
Checked By	SWH	Equipment	Takeuchi TB138					
Surface Elevation (ft) Vertical Datum	662		Easting (X) Northing (Y)	1179575.94 560428.88		Coordinate System Horizontal Datum		

Elevation (feet)	Depth (feet)	SAMPLE		Graphic Log	Group Classification	MATERIAL DESCRIPTION	Moisture Content (%)	Fines Content (%)	REMARKS
		Testing Sample	Sample Name Testing						
661	1				TS	Vegetation/topsoil (loose, dry to moist)			Numerous cobbles and occasional boulders encountered from 1 to 9 feet bgs
660	2		SA		GP	Brown gravel with sand, cobbles and occasional boulders (medium dense, moist)	5	5	
660	3				GM	Gray silty gravel with sand (medium dense, moist to wet) (outwash)			
660	4				GM	Gray silty gravel with sand (medium dense, moist to wet) (outwash)			
661	5		2						
666	6								
666	7								
664	8								
663	9		SA				18	17	Minor to moderate groundwater seepage observed at 9 feet bgs
662	10								

Notes: See Figure A-1 for explanation of symbols.
The depths on the test pit logs are based on an average of measurements across the test pit and should be considered accurate to 1/2 foot.
Coordinates Data Source: Horizontal approximated based on . Vertical approximated based on .

Log of Test Pit TH-1A



Project: Proposed Maintenance Facility Nisqually State Park
Project Location: Pierce County, Washington
Project Number: 2935-067-00

Date: 12/1/20 Path: P:\2935067\GINT\2935067\00.GPJ DBLlibrary\Library\GEOENGINEERS_DF_STD_US_JUNE_2017.GLB\GER_TESTPIT_1P_GEOTEC_SF

Date Excavated	12/1/2020	Total Depth (ft)	8	Logged By	SLG	Excavator	Kelly's Excavating	Groundwater not observed
				Checked By	SWH	Equipment	Takeuchi TB138	Caving not observed
Surface Elevation (ft) Vertical Datum	664		Easting (X) Northing (Y)	1179565.89 560254.63		Coordinate System Horizontal Datum		

Elevation (feet)	Depth (feet)	SAMPLE		Graphic Log	Group Classification	MATERIAL DESCRIPTION	Moisture Content (%)	Fines Content (%)	REMARKS
		Testing Sample	Sample Name Testing						
					DUFF	Forest duff			
663	1				SM	Brown silty sand with gravel and organic matter (loose to medium dense, moist)	20	20	
662	2		g14		SW-SM	Brown sand with silt and gravel (medium dense, moist) (outwash)	10	12	
661	3								
660	4								
659	5		g13		SW-SM	Brown sand with silt and gravel (medium dense, moist) (outwash)	10	12	
658	6								
657	7								
656	8								Refusal at 8 feet on boulders

Notes: See Figure A-1 for explanation of symbols.
The depths on the test pit logs are based on an average of measurements across the test pit and should be considered accurate to 1/2 foot.
Coordinates Data Source: Horizontal approximated based on . Vertical approximated based on .

Log of Test Pit TH-1B



Project: Proposed Maintenance Facility Nisqually State Park
Project Location: Pierce County, Washington
Project Number: 2935-067-00

Figure A-3
Sheet 1 of 1

Date: 12/1/20 Path: P:\2935067\GINT\293506700.GPJ DBLibrary\Library\GEOENGINEERS_DF_STD_US_JUNE_2017.GLB\GERB_TESTPIT_IP_GEOtec_MF

Date Excavated	12/1/2020	Total Depth (ft)	9	Logged By	SLG	Excavator	Kelly's Excavating	Groundwater not observed
				Checked By	SWH	Equipment	Takeuchi TB138	Caving not observed
Surface Elevation (ft) Vertical Datum	662			Easting (X) Northing (Y)	1179837.3 560445.85		Coordinate System Horizontal Datum	

Elevation (feet)	Depth (feet)	SAMPLE		Graphic Log	Group Classification	MATERIAL DESCRIPTION	Moisture Content (%)	Fines Content (%)	REMARKS
		Testing Sample	Sample Name Testing						
					DUFF	Forest duff			
661	1				SM	Brown silty sand with gravel and organic matter (loose to medium dense, moist to wet)			
660	2		MC		SM	Brown silty sand with gravel and organic matter (loose to medium dense, moist to wet)	24		4.6 percent organics 2 to 3 feet picked up numerous cobbles and boulders
659	3				GM	Brown silty gravel with sand, cobbles and occasional boulders (medium dense, moist to wet) (outwash)			
658	4		GM		GM	Brown silty gravel with sand, cobbles and occasional boulders (medium dense, moist to wet) (outwash)	11	20	
657	5				SM	Brown silty sand with occasional gravel (medium dense, moist) (outwash)			
656	6		SM		SM	Brown silty sand with occasional gravel (medium dense, moist) (outwash)	15	15	
655	7				ML	Gray-tan red mottled silt with sand (hard to very hard, moist) (glaciolacustrine)			
654	8		4		ML	Gray-tan red mottled silt with sand (hard to very hard, moist) (glaciolacustrine)			Denser digging at approximately 8 1/2 feet per operator
653	9								

Notes: See Figure A-1 for explanation of symbols.
The depths on the test pit logs are based on an average of measurements across the test pit and should be considered accurate to 1/2 foot.
Coordinates Data Source: Horizontal approximated based on . Vertical approximated based on .

Log of Test Pit TH-1C



Project: Proposed Maintenance Facility Nisqually State Park
Project Location: Pierce County, Washington
Project Number: 2935-067-00

Figure A-4
Sheet 1 of 1

Date: 12/1/20 Path: P:\2935067\GINT\2935067\00.GPJ DBLlibrary\Library\GEOENGINEERS_DF STD_US_JUNE_2017.GLB\GERB_TESTPIT_IP_GEOtec_SF

Date Excavated	7/6/2021	Total Depth (ft)	10.5	Logged By	CJL	Excavator	Kelly's Excavating, Inc.	Groundwater not observed
				Checked By	SWH	Equipment	Komatsu PC 120	See "Remarks" section for caving observed
Surface Elevation (ft)	Undetermined		Latitude	46.85941745		Coordinate System		
Vertical Datum			Longitude	-122.33712285		Horizontal Datum		

Elevation (feet)	Depth (feet)	SAMPLE		Graphic Log	Group Classification	MATERIAL DESCRIPTION	Moisture Content (%)	Fines Content (%)	REMARKS
		Testing Sample	Sample Name Testing						
					DUFF	6 inches of forest duff			
	1				GP-GM	Brown fine to coarse gravel with silt and sand and occasional cobbles (medium dense, moist) (outwash)			
	2					Grades to dense			
	3		1						
	4		2				4	8	
	5				SP	Gray fine to medium sand with gravel and trace silt (loose, moist) (outwash)			
	6		3				16	4	Severe caving from 6 to 10½ feet
	7								
	8								
	9				GP	Gray fine to coarse gravel with sand, cobbles and occasional boulders (loose, moist) (outwash)			
	10		4						

Notes: See Figure 3 for explanation of symbols.
The depths on the test pit logs are based on an average of measurements across the test pit and should be considered accurate to ½ foot.
Coordinates Data Source: Horizontal approximated based on . Vertical approximated based on .

Log of Test Pit Area 1-1 (PIT-1)



Project: Nisqually State Park Wastewater Treatment Plant
Project Location: Eatonville, Washington
Project Number: 2935-067-01

Figure 4
Sheet 1 of 1

Date: 8/12/21 Path: P:\2935\067\GINT\293506701.GPJ DBLibrary\Library\GEOENGINEERS_DF_STD_US_JUNE_2017\GLB\GEI6_TESTPIT_1P_GIOTEC_%F

Date Excavated	7/6/2021	Total Depth (ft)	9.5	Logged By	CJL	Excavator	Kelly's Excavating, Inc.	Groundwater not observed
				Checked By	SWH	Equipment	Komatsu PC 120	See "Remarks" section for caving observed
Surface Elevation (ft)	Undetermined		Latitude	46.85960561		Coordinate System		
Vertical Datum			Longitude	-122.33680785		Horizontal Datum		

Elevation (feet)	Depth (feet)	SAMPLE		Graphic Log	Group Classification	MATERIAL DESCRIPTION	Moisture Content (%)	Fines Content (%)	REMARKS
		Testing Sample	Sample Name Testing						
					DUFF	12 inches of forest duff			
	1				GP-GM	Brown fine to coarse gravel with silt, sand and cobbles (loose, moist) (outwash)			Severe caving from 2 to 9½ feet
	2	1							
	3								
	4				GW	Brown-gray fine to coarse gravel with sand and trace silt (loose, moist) (outwash)			
	5		2				2	4	
	6								
	7					Grades to with occasional boulders			
	8								
	9		3						

Notes: See Figure 3 for explanation of symbols.
The depths on the test pit logs are based on an average of measurements across the test pit and should be considered accurate to ½ foot.
Coordinates Data Source: Horizontal approximated based on . Vertical approximated based on .







Log of Test Pit Area 1-2



Project: Nisqually State Park Wastewater Treatment Plant
Project Location: Eatonville, Washington
Project Number: 2935-067-01

Date: 8/12/21 Path: P:\2935\067\GINT\293506701.GPJ DBLibrary\Library\GEOENGINEERS_DF_STD_US_JUNE_2017\GLB\GEI6_TESTPIT_1P_GEOTEC_%F

Date Excavated	7/7/2021	Total Depth (ft)	10	Logged By	CJL	Excavator	Kelly's Excavating, Inc.	Groundwater not observed
				Checked By	SWH	Equipment	Komatsu PC 120	See "Remarks" section for caving observed
Surface Elevation (ft)	Undetermined		Latitude	46.85968707		Coordinate System		
Vertical Datum			Longitude	-122.33655649		Horizontal Datum		

Elevation (feet)	Depth (feet)	SAMPLE		Graphic Log	Group Classification	MATERIAL DESCRIPTION	Moisture Content (%)	Fines Content (%)	REMARKS
		Testing Sample	Sample Name Testing						
					DUFF	7 inches of forest duff			
	1				SM	Brown silty fine to coarse sand with gravel (loose, moist) (outwash)			
	2		g ₁₊₂				6	14	
	3		2		GP-GM	Brown fine to coarse gravel with silt and sand and occasional cobbles (loose, moist) (outwash)			Severe caving from 3 to 10 feet
	4								
	5				GW	Brown-gray fine to coarse gravel with sand and occasional cobbles (loose, moist) (outwash)			
	6		g ₆₋₁₀			Grades to with cobbles and occasional boulders	5.5	2	
	7								
	8								
	9								
	10		4						

Notes: See Figure 3 for explanation of symbols.
The depths on the test pit logs are based on an average of measurements across the test pit and should be considered accurate to 1/2 foot.
Coordinates Data Source: Horizontal approximated based on . Vertical approximated based on .





Log of Test Pit Area 1-3 (PIT-2)



Project: Nisqually State Park Wastewater Treatment Plant
Project Location: Eatonville, Washington
Project Number: 2935-067-01

Date: 8/12/21 Path: P:\2935\067\GINT\293506701.GPJ DBLibrary\Library\GEOENGINEERS_DF_STD_US_JUNE_2017\GLB\GEI6_TESTPIT_1P_GEOTEC_%F

Date Excavated	7/8/2021	Total Depth (ft)	5.5	Logged By	CJL	Excavator	Kelly's Excavating, Inc.	Groundwater not observed
				Checked By	SWH	Equipment	Komatsu PC 120	Caving not observed
Surface Elevation (ft)	Undetermined		Latitude	46.85738345		Coordinate System		
Vertical Datum			Longitude	-122.34102403		Horizontal Datum		

Elevation (feet)	Depth (feet)	SAMPLE		Graphic Log	Group Classification	MATERIAL DESCRIPTION	Moisture Content (%)	Fines Content (%)	REMARKS
		Testing Sample	Sample Name Testing						
					DUFF	6 inches of forest duff			
	1				SM	Light gray silty fine to medium sand with gravel and cobbles (dense to very dense, moist) (glacial till)			
	2		1						
	4		2			Grades to gray with occasional iron-oxide staining			
	5		3			Grades to no iron-oxide staining, with occasional boulders			

Notes: See Figure 3 for explanation of symbols.
The depths on the test pit logs are based on an average of measurements across the test pit and should be considered accurate to 1/2 foot.
Coordinates Data Source: Horizontal approximated based on . Vertical approximated based on .

Log of Test Pit Area 2-1



Project: Nisqually State Park Wastewater Treatment Plant
Project Location: Eatonville, Washington
Project Number: 2935-067-01

Date: 8/12/21 Path: P:\2935\067\GINT\293506701.GPJ DBLibrary\Library\GEOENGINEERS_DF_STD_US_JUNE_2017.GLB\GEI6_TESTPIT_IP_GEOTEC_%F

Date Excavated	7/8/2021	Total Depth (ft)	5.5	Logged By	CJL	Excavator	Kelly's Excavating, Inc.	Groundwater not observed
				Checked By	SWH	Equipment	Takeuchi TB 138 Mini Excavator	Caving not observed
Surface Elevation (ft)	Undetermined		Latitude	46.85698547		Coordinate System		
Vertical Datum			Longitude	-122.341330049		Horizontal Datum		

Elevation (feet)	Depth (feet)	SAMPLE		Graphic Log	Group Classification	MATERIAL DESCRIPTION	Moisture Content (%)	Fines Content (%)	REMARKS
		Testing Sample	Sample Name Testing						
					DUFF	6 inches of forest duff			
	1				SM	Light brown-gray silty fine to medium sand with gravel and cobbles (dense, moist) (weathered till)			
	2				SM				
	3		1 SA				11	47	
	4				SM	Gray with occasional iron-oxide staining silty fine to medium sand with gravel and cobbles (very dense, moist) (glacial till?)			
	5		2			Grades to no iron-oxide staining			

Notes: See Figure 3 for explanation of symbols.
The depths on the test pit logs are based on an average of measurements across the test pit and should be considered accurate to 1/2 foot.
Coordinates Data Source: Horizontal approximated based on . Vertical approximated based on .







Log of Test Pit Area 2-2



Project: Nisqually State Park Wastewater Treatment Plant
Project Location: Eatonville, Washington
Project Number: 2935-067-01

Date: 8/12/21 Path: P:\2935\067\GINT\293506701.GPJ DBLibrary\Library\GEOENGINEERS_DF_STD_US_JUNE_2017\GLB\GEI6_TESTPIT_IP_GEOTEC_%F

Date Excavated	7/8/2021	Total Depth (ft)	5.5	Logged By	CJL	Excavator	Kelly's Excavating, Inc.	Groundwater not observed
				Checked By	SWH	Equipment	Takeuchi TB 138 Mini Excavator	Caving not observed
Surface Elevation (ft)	Undetermined		Latitude	46.85688087		Coordinate System		
Vertical Datum			Longitude	-122.34151531		Horizontal Datum		

Elevation (feet)	Depth (feet)	SAMPLE		Graphic Log	Group Classification	MATERIAL DESCRIPTION	Moisture Content (%)	Fines Content (%)	REMARKS
		Testing Sample	Sample Name Testing						
					DUFF	6 inches of forest duff			
	1				SM	Light brown-gray silty fine to medium sand with gravel and cobbles (dense, moist) (weathered till)			
	2		9#			Grades to with occasional boulders	9	42	
	3								
	4				SM	Gray with occasional iron-oxide staining silty fine to medium sand with gravel, cobbles and occasional boulders (very dense, moist) (glacial till)			
	5		2			Grades to no iron-oxide staining			

Notes: See Figure 3 for explanation of symbols.
The depths on the test pit logs are based on an average of measurements across the test pit and should be considered accurate to 1/2 foot.
Coordinates Data Source: Horizontal approximated based on . Vertical approximated based on .

Log of Test Pit Area 2-3



Project: Nisqually State Park Wastewater Treatment Plant
Project Location: Eatonville, Washington
Project Number: 2935-067-01

Date: 8/12/21 Path: P:\2935067\GINT\293506701.GPJ DBLibrary\Library\GEOENGINEERS_DF_STD_US_JUNE_2017\GLB\GEI6_TESTPIT_IP_GEOTEC_%F

APPENDIX C
Report Limitations and Guidelines for Use

APPENDIX C

REPORT LIMITATIONS AND GUIDELINES FOR USE¹

This appendix provides information to help you manage your risks with respect to the use of this report.

Geotechnical Services Are Performed For Specific Purposes, Persons and Projects

This report has been prepared for the exclusive use of Robert W. Droll, Landscape Architects and their authorized agents. This report is not intended for use by others, and the information contained herein is not applicable to other sites.

GeoEngineers structures our services to meet the specific needs of our clients. For example, a geotechnical or geologic study conducted for a civil engineer or architect may not fulfill the needs of a construction contractor or even another civil engineer or architect that are involved in the same project. Because each geotechnical or geologic study is unique, each geotechnical engineering or geologic report is unique, prepared solely for the specific client and project site. Our report is prepared for the exclusive use of our Client. No other party may rely on the product of our services unless we agree in advance to such reliance in writing. This is to provide our firm with reasonable protection against open-ended liability claims by third parties with whom there would otherwise be no contractual limits to their actions. Within the limitations of scope, schedule and budget, our services have been executed in accordance with our Agreement with the Client and generally accepted geotechnical practices in this area at the time this report was prepared. This report should not be applied for any purpose or project except the one originally contemplated.

A Geotechnical Engineering or Geologic Report is Based on a Unique Set of Project-Specific Factors

This report has been prepared for the planned Wastewater Treatment Plant and Sewer Line improvements at Nisqually State Park in Pierce County, Washington. GeoEngineers considered a number of unique, project-specific factors when establishing the scope of services for this project and report. Unless GeoEngineers specifically indicates otherwise, do not rely on this report if it was:

- Not prepared for you,
- Not prepared for your project,
- Not prepared for the specific site explored, or
- Completed before important project changes were made.

For example, changes that can affect the applicability of this report include those that affect:

- The function of the proposed structure;
- Elevation, configuration, location, orientation or weight of the proposed structure;
- Composition of the design team; or
- Project ownership.

¹ Developed based on material provided by ASFE, Professional Firms Practicing in the Geosciences; www.asfe.org.

If important changes are made after the date of this report, GeoEngineers should be given the opportunity to review our interpretations and recommendations and provide written modifications or confirmation, as appropriate.

Subsurface Conditions Can Change

This report is based on conditions that existed at the time the study was performed. The findings and conclusions of this report may be affected by the passage of time, by manmade events such as construction on or adjacent to the site, or by natural events such as floods, earthquakes, slope instability or groundwater fluctuations. Always contact GeoEngineers before applying a report to determine if it remains applicable.

Most Geotechnical and Geologic Findings are Professional Opinions

Our interpretations of subsurface conditions are based on field observations from widely spaced sampling locations at the site. Site exploration identifies subsurface conditions only at those points where subsurface tests are conducted or samples are taken. GeoEngineers reviewed field and laboratory data and then applied our professional judgment to render an opinion about subsurface conditions throughout the site. Actual subsurface conditions may differ, sometimes significantly, from those indicated in this report. Our report, conclusions and interpretations should not be construed as a warranty of the subsurface conditions.

Geotechnical Engineering Report Recommendations are Not Final

Do not over-rely on the preliminary construction recommendations included in this report. These recommendations are not final, because they were developed principally from GeoEngineers' professional judgment and opinion. GeoEngineers' recommendations can be finalized only by observing actual subsurface conditions revealed during construction. GeoEngineers cannot assume responsibility or liability for this report's recommendations if we do not perform construction observation.

Sufficient monitoring, testing and consultation by GeoEngineers should be provided during construction to confirm that the conditions encountered are consistent with those indicated by the explorations, to provide recommendations for design changes should the conditions revealed during the work differ from those anticipated, and to evaluate whether or not earthwork activities are completed in accordance with our recommendations. Retaining GeoEngineers for construction observation for this project is the most effective method of managing the risks associated with unanticipated conditions.

A Geotechnical Engineering or Geologic Report Could be Subject to Misinterpretation

Misinterpretation of this report by other design team members can result in costly problems. You could lower that risk by having GeoEngineers confer with appropriate members of the design team after submitting the report. Also retain GeoEngineers to review pertinent elements of the design team's plans and specifications. Contractors can also misinterpret a geotechnical engineering or geologic report. Reduce that risk by having GeoEngineers participate in pre-bid and preconstruction conferences, and by providing construction observation.

Do Not Redraw the Exploration Logs

Geotechnical engineers and geologists prepare final boring and testing logs based upon their interpretation of field logs and laboratory data. To prevent errors or omissions, the logs included in a geotechnical engineering or geologic report should never be redrawn for inclusion in architectural or other design

drawings. Only photographic or electronic reproduction is acceptable, but recognize that separating logs from the report can elevate risk.

Give Contractors a Complete Report and Guidance

Some owners and design professionals believe they can make contractors liable for unanticipated subsurface conditions by limiting what they provide for bid preparation. To help prevent costly problems, give contractors the complete geotechnical engineering or geologic report, but preface it with a clearly written letter of transmittal. In that letter, advise contractors that the report was not prepared for purposes of bid development and that the report's accuracy is limited; encourage them to confer with GeoEngineers and/or to conduct additional study to obtain the specific types of information they need or prefer. A pre-bid conference can also be valuable. Be sure contractors have sufficient time to perform additional study. Only then might an owner be in a position to give contractors the best information available, while requiring them to at least share the financial responsibilities stemming from unanticipated conditions. Further, a contingency for unanticipated conditions should be included in your project budget and schedule.

Contractors are Responsible for Site Safety on Their Own Construction Projects

Our geotechnical recommendations are not intended to direct the contractor's procedures, methods, schedule or management of the work site. The contractor is solely responsible for job site safety and for managing construction operations to minimize risks to on-site personnel and to adjacent properties.

Read These Provisions Closely

Some clients, design professionals and contractors may not recognize that the geoscience practices (geotechnical engineering or geology) are far less exact than other engineering and natural science disciplines. This lack of understanding can create unrealistic expectations that could lead to disappointments, claims and disputes. GeoEngineers includes these explanatory "limitations" provisions in our reports to help reduce such risks. Please confer with GeoEngineers if you are unclear how these "Report Limitations and Guidelines for Use" apply to your project or site.

Geotechnical, Geologic and Environmental Reports Should Not be Interchanged

The equipment, techniques and personnel used to perform an environmental study differ significantly from those used to perform a geotechnical or geologic study and vice versa. For that reason, a geotechnical engineering or geologic report does not usually relate any environmental findings, conclusions or recommendations; e.g., about the likelihood of encountering underground storage tanks or regulated contaminants. Similarly, environmental reports are not used to address geotechnical or geologic concerns regarding a specific project.

Biological Pollutants

GeoEngineers' Scope of Work specifically excludes the investigation, detection, prevention, or assessment of the presence of Biological Pollutants in or around any structure. Accordingly, this report includes no interpretations, recommendations, findings, or conclusions for the purpose of detecting, preventing, assessing, or abating Biological Pollutants and no conclusions or inferences should be drawn regarding Biological Pollutants, as they may relate to this project. The term "Biological Pollutants" includes, but is not limited to, molds, fungi, spores, bacteria, and viruses, and/or any of their byproducts. If Client desires these specialized services, they should be obtained from a consultant who offers services in this specialized field.

Appendix B - Earthwork Calculations
For Information Only-Contractor is responsible for deriving their
own earthwork quantities.



PO Box 640
 1116 1st St.
 Cosmopolis, WA 98537

June 29, 2022

Earthwork Services Job# 42352

Jonah Hayes
 RWD Landscape Architects
 4405 7th Ave. SE, Ste. 203
 Lacey, WA 98503

RE: Nisqually State Park PH2

Dear Jonah,

Enclosed please find grid elevation, cut/fill graphics, and volumes for this project, which was calculated using the average end area method and the following assumptions:

1. A **stripping** depth of **12"** was applied to the **existing terrain**.
2. A depth of **8"** from design elevations to subgrade in the **concrete pad and walks**.
3. A depth of **15"** from design elevations to subgrade in the **heavy duty paving**.
4. A depth of **6"** from design elevations to subgrade in the **light duty paving and crushed rock**.
5. A depth of **3"** from design elevations to subgrade in the **island and landscaping**.
6. A depth of **18"** from design elevations to subgrade in the **bioretention cell**.
7. A depth of **18"** from finish floor elevations to subgrade in the **building**.

TOTAL RAW VOLUMES IN PLACE

(Volumes are in Cubic Yards)

Activity	Area (ft ²)	Cut Volume	Fill Volume	Strip/Demo Volume
Finish Site	79,702	6,925	1,050	2,966

Please call after you have reviewed this information if you have any questions.

* Raw volumes are calculated after existing terrain has been stripped, thus creating less cut and more fill of suitable material. Raw volumes have not been adjusted to reflect shrink or swell for compaction and expansion and are volumetric areas only.

Volume Report
Subgrade vs. Stripped

	Total	Cut	Area Fill	OnGrade	Volume		Comp/Ratio		Compact		Export -Import	Change Per .1 Ft
					Cut	Fill	Cut	Fill	Cut	Fill		
Bioretention Cell	11,704	11,704	0	0	3,325	0	1.00	1.00	3,325	0	3,325	43
Building	3,097	0	3,097	0	0	153	1.00	1.00	0	153	-153	11
Conc. Pad	270	0	270	0	0	4	1.00	1.00	0	4	-4	1
Crushed Rock 1	415	14	392	9	0	8	1.00	1.00	0	8	-8	2
Crushed Rock 2	3,082	2,759	240	83	282	3	1.00	1.00	282	3	279	11
Crushed Rock 3	219	0	219	0	0	20	1.00	1.00	0	20	-20	1
Crushed Sub:	3,716	2,773	851	92	282	31			282	31	251	14
HD Paving	17,697	16,483	683	531	961	15	1.00	1.00	961	15	946	66
Island	806	403	277	126	8	4	1.00	1.00	8	4	4	3
Landscaping	29,495	18,795	9,825	875	2,130	467	1.00	1.00	2,130	467	1,663	109
LD Paving 1	1,606	884	444	278	13	7	1.00	1.00	13	7	6	6
LD Paving 2	1,630	1,614	11	5	200	0	1.00	1.00	200	0	200	6
LD Sub:	3,236	2,498	455	283	213	7			213	7	206	12
Walk 1	9,633	410	8,980	243	6	365	1.00	1.00	6	365	-359	36
Walk 2	48	0	48	0	0	4	1.00	1.00	0	4	-4	0
Walk Sub:	9,681	410	9,028	243	6	369			6	369	-363	36
Regions Total	79,702	53,066	24,486	2,150	6,925	1,050			6,925	1,050	5,875	295

Stripping Qtys	Plane Area	Slope Area	Depth	Volume
Stripping	79,702	80,090	1.000	2,966

Sectional Qtys	Plane Area	Slope Area	Depth	Volume
Bioretention Cell	11,704	12,094	1.500	672
Building	3,097	3,099	1.500	172
Conc. Pad	270	270	0.667	7
Crushed Rock 1	415	442	0.500	8
Crushed Rock 2	3,082	3,084	0.500	57
Crushed Rock 3	219	224	0.500	4
Crushed Sub:	3,716	3,750		69
HD Paving	17,697	17,707	1.250	820
Island	806	807	0.250	7
Landscaping	29,495	30,360	0.250	281
LD Paving 1	1,606	1,606	0.500	30
LD Paving 2	1,630	1,631	0.500	30
LD Sub:	3,236	3,237		60
Walk 1	9,633	9,641	0.667	238
Walk 2	48	48	0.667	1
Walk Sub:	9,681	9,689		239
Sectional Total	79,702	81,013		2,327

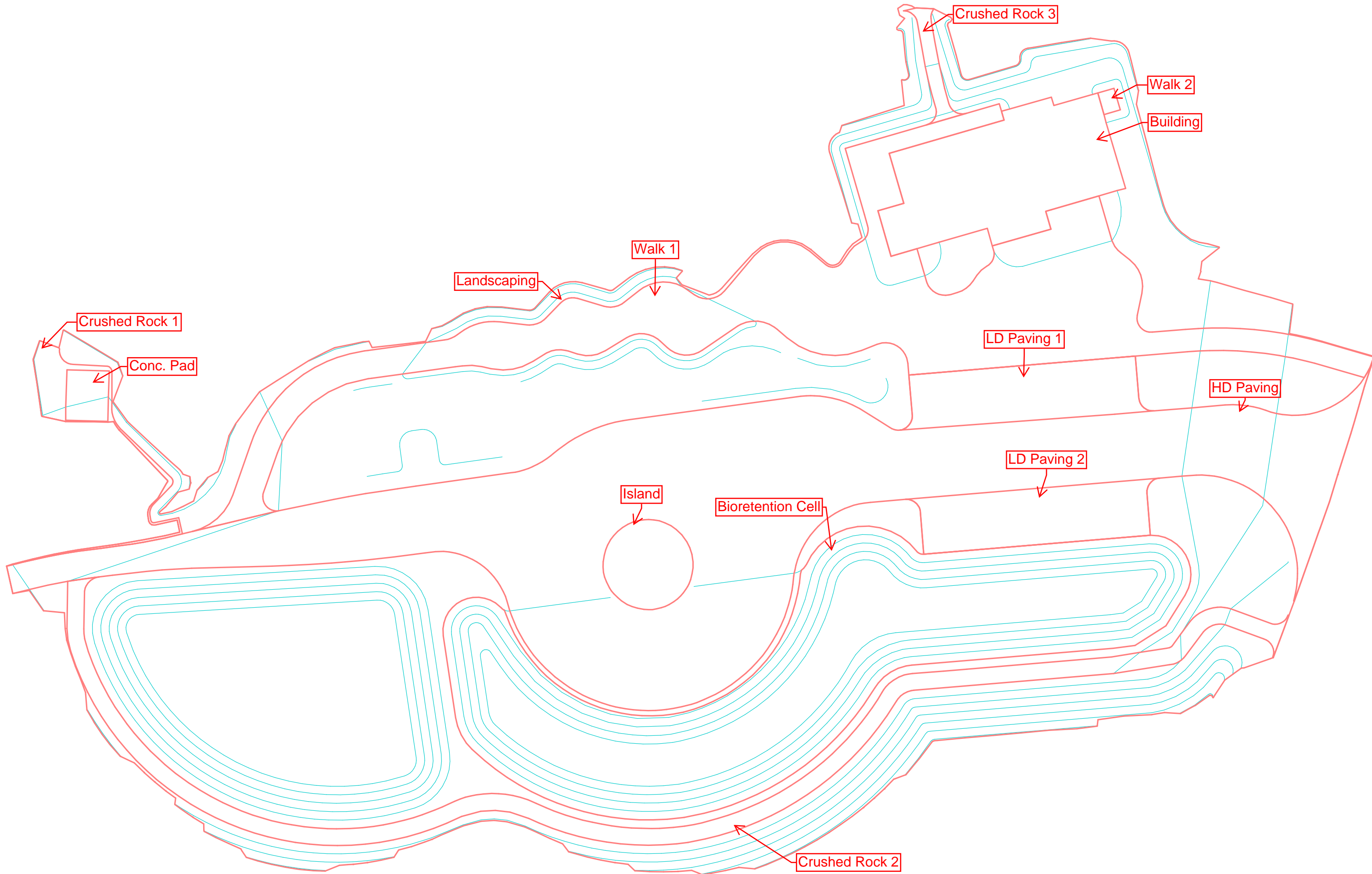



PO Box 640
 1116 1st St.
 Cosmopolis, WA 98537

November 2, 2020

Earthwork Services Job # 41030

Bob Droll
 RWD Landscape Architects
 4405 7th Ave. SE, Ste. 203
 Lacey, WA 98503

RE: Nisqually State Park PH2 Schedule D

Dear Bob,

Enclosed please find grid elevation, cut/fill graphics, and volumes for this project, which was calculated using the average end area method and the following assumptions:

1. A **stripping** depth of **6"** was applied to the **existing terrain**.
2. A depth of **8"** from design elevations to subgrade in the **concrete pavement** and **crushed surfacing Types A&B**.
3. A depth of **6"** from design elevations to subgrade in the **concrete ramp**.
4. A depth of **10"** from design elevations to subgrade in the **heavy pavement**.
5. A depth of **0"** from design elevations to subgrade in the **landscaping** and **landing mass grading**.

TOTAL RAW VOLUMES IN PLACE

(Volumes are in Cubic Yards)

Activity	Area (ft ²)	Cut Volume	Fill Volume	Stripping/Demo Volume
Vault Ex	86	12	0	2
Finish Site	49,864	548	381	927
TOTAL SITE	49,864	560	381	929

Please call after you have reviewed this information if you have any questions.

* Raw volumes are calculated after existing terrain has been stripped, thus creating less cut and more fill of suitable material. Raw volumes have not been adjusted to reflect shrink or swell for compaction and expansion and are volumetric areas only.

Volume Report
Subgrade vs. Stripped

	Total	Cut	Area		Volume		Comp/Ratio		Compact		Export -Import	Change Per .1 Ft
			Fill	OnGrade	Cut	Fill	Cut	Fill	Cut	Fill		
Conc Ramp	244	32	142	70	0	4	1.00	1.00	0	4	-4	1
Crushed Surfacing Type A 1	16,553	8,395	4,609	3,549	86	79	1.00	1.00	86	79	7	61
Crushed Surfacing Type A 2	273	219	0	54	2	0	1.00	1.00	2	0	2	1
Crushed Surfacing Type B 1	1,543	507	680	356	5	12	1.00	1.00	5	12	-7	6
Crushed Surfacing Type B 2	347	293	16	38	4	0	1.00	1.00	4	0	4	1
Crushed Surfacing Type B 3	1,077	655	238	184	9	2	1.00	1.00	9	2	7	4
Crushed Surfacing Type B 4	462	183	53	226	1	2	1.00	1.00	1	2	-1	2
Crushed Sub:	20,255	10,252	5,596	4,407	107	95			107	95	12	75
Landing Mass Grading	4,385	3,611	552	222	306	7	1.00	1.00	306	7	299	16
Landscaping 1	6,875	1,245	5,142	488	30	123	1.00	1.00	30	123	-93	25
Landscaping 2	2,253	0	2,241	12	0	51	1.00	1.00	0	51	-51	8
Landscaping Sub:	9,128	1,245	7,383	500	30	174			30	174	-144	33
Pavement Conc 1	2,348	0	2,164	184	0	38	1.00	1.00	0	38	-38	9
Pavement Heavy	13,504	6,163	4,141	3,200	105	63	1.00	1.00	105	63	42	50
Pavement Sub:	15,852	6,163	6,305	3,384	105	101			105	101	4	59
Regions Total	49,864	21,303	19,978	8,583	548	381			548	381	167	184

<u>Stripping Qtys</u>	<u>Plane Area</u>	<u>Slope Area</u>	<u>Depth</u>	<u>Volume</u>
Site Stripping 1	45,471	45,537	0.500	843
Site Stripping 2	4,385	4,520	0.500	84
Site Sub:	49,856	50,057		927
Stripping Total	49,856	50,057		927

<u>Sectional Qtys</u>	<u>Plane Area</u>	<u>Slope Area</u>	<u>Depth</u>	<u>Volume</u>
Conc Ramp	243	244	0.500	5
Crushed Surfacing Type A 1	16,553	16,559	0.667	409
Crushed Surfacing Type A 2	273	273	0.667	7
Crushed Surfacing Type B 1	1,542	1,563	0.667	39
Crushed Surfacing Type B 2	347	362	0.667	9
Crushed Surfacing Type B 3	1,077	1,089	0.667	27
Crushed Surfacing Type B 4	462	467	0.667	12
Crushed Sub:	20,254	20,313		503
Landing Mass Grading	4,385	4,388	0.000	0
Landscaping 1	6,875	7,062	0.000	0
Landscaping 2	2,253	2,254	0.000	0
Landscaping Sub:	9,128	9,316		0
Pavement Conc 1	2,348	2,348	0.667	58
Pavement Heavy	13,504	13,515	0.833	417
Pavement Sub:	15,852	15,863		475
Sectional Total	49,862	50,124		983

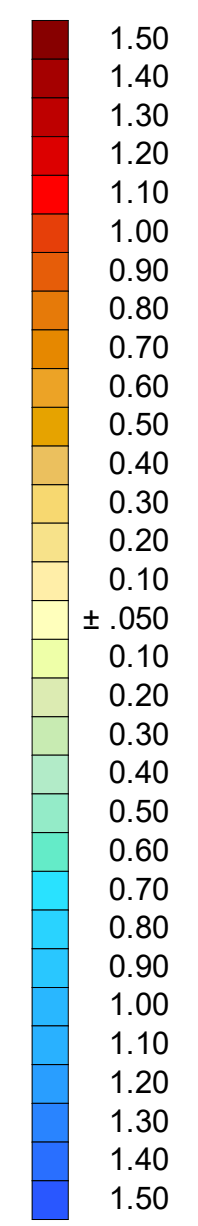
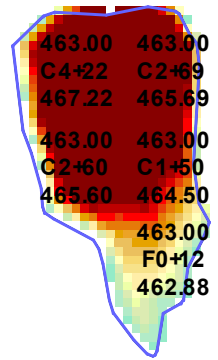

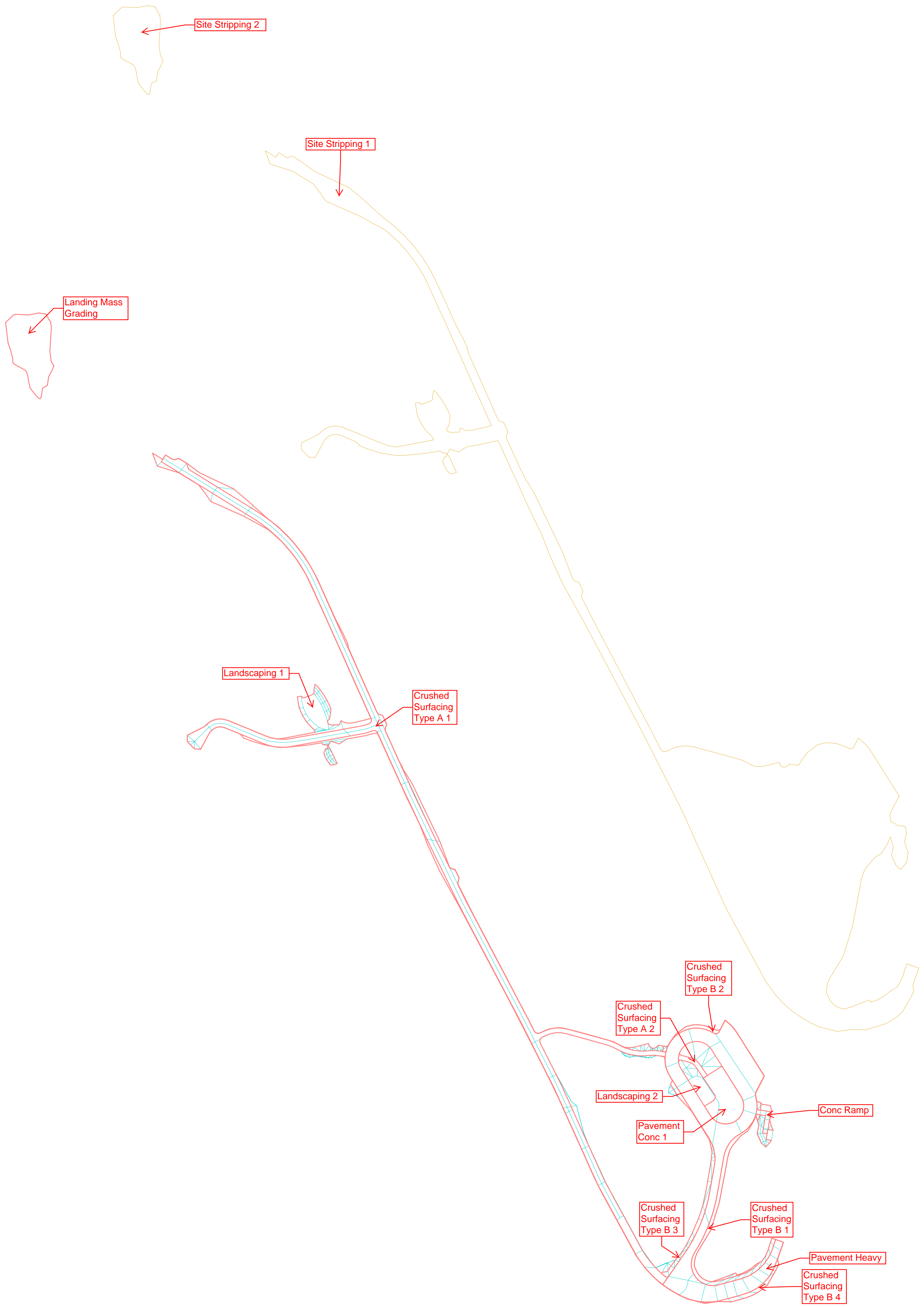

Appendix C - Diamond Pier Foundation Installation Manual

DiamondPier

Quick Installation Overview

IMPORTANT: Read Full *Diamond Pier Installation Manual* and View the *Installation Video* at: www.DiamondPiers.com

Before You Purchase Page references refer to the Full Installation Manual

- 1. Know Your Soils** See "Normal Soil Conditions" (page 5) – 1500 psf min supporting soils.
- 2. Check Your Loads** "Residential Diamond Pier Load Chart" (page 6) shows Equivalency to Traditional Concrete Footings.
- 3. Get Building Permit from Local Municipality** Provide Diamond Pier model size and code compliance documentation. See "Use and Applications" (page 7).
- 4. Locate Buried Utilities** Determine safety zones and adequate clearances (page 8).

Documents to Submit with a Permit Application

- ESR-1895 Code Compliance Document
- Wisconsin UDC Approval Evaluation
- Detail Drawings and Load Chart
- See "Use and Applications" (page 7)

To Get Started You will Need...

• The Proper Sized Diamond Pier

Includes:

- 1 - Concrete Head
- 4 - Pins
- 4 - Plugs
- 4 - Caps



- **Driving Bit**
1-1/8" hex shaft



- **Demo/Breaker Hammer**
35 lb.+



Ask dealer about rental

Other Common Tools Required...

- Square-Edge Shovel
- Torpedo Level
- Pipe Wrench
- Ear Protection
- Sledgehammer
- Tape Measure
- Proper Safety Goggles
- Insulated Gloves & Protective Clothing

Diamond Pier® Detail

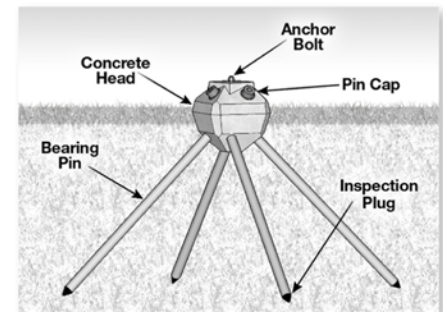

Install in Minutes A minimum two-person crew is recommended. See Full Installation Instructions pages (11-14).



- 1. Install plugs in pins** to prevent soil from entering as they are driven into the ground. Inspectors can then use a tape measure to verify pin length after installation.
- 2. Lay out string** approx. 12–14" above the ground on center location of post/pier to allow for quick reference point.
- 3. Remove soil** the same size as bottom half of concrete head, approx. 6" depth. Note: Pier can be buried for aesthetic reasons, but access to top of pier needs to be maintained. Concrete slabs, patios, and other products installed **MUST NOT** interfere with the Diamond Pier system and the attached post/beam assembly. Expansion joints are commonly used to protect the system. Proper drainage must also be maintained.
- 4. Set concrete head** in hole and, keeping the pin centered in the driving hole, carefully set each pin 6–12" into soil tapping with a short grip on sledgehammer until pier is locked into a level position. Note: The edges on the flat top of the concrete head do not have to align exactly with the sides of the post or post bracket as long as the bracket is fully supported by the concrete for proper weight distribution. Piers can be nested next to each other to provide more loading, but if closer than 3' on-center, a 13% load reduction should be applied to each pier.
- 5. With driving bit** attached to the automatic hammer, drive pins in evenly from side to side in equal increments, approx. 1–2' each until pin is approx. 6" out. Then double check pier position before final driving of the pins to ¾" out for cap attachment. Note: One person should hold pin to limit vibration to pier while pin is driven.
- 6. Be sure the pin length** is inspected per permit requirements before caps are applied.

Removal/Repositioning if Obstruction Encountered

If a pin stops moving when being driven in, STOP driving the pin. Put pencil mark on pin by head to indicate if pin is moving. With other pins part way in, use the automatic hammer for approx. 10–20 seconds, or give the pin one or two firm square hits with the sledgehammer. If it still will not move, then remove and reposition the pier. To remove, spin and pry a pin simultaneously using a pipe wrench and pry bar. If the obstruction is close to the surface, it may be dug up and removed. Then recompact the soils with the sledgehammer, and reset the pier. See Installation Manual (page 13) and Removal Video available at www.DiamondPiers.com.



Register Your Product Warranty See information at www.DiamondPiers.com

WARNING: Do not install Diamond Pier foundations before all underground utilities have been located, marked, and de-energized. See "Locate Buried Utilities" in the full Installation Manual at www.DiamondPiers.com

DiamondPier®

FOUNDATION SYSTEM

From
this...



...to this

Before Lunch!

Complete Projects 1 to 2 Days Faster
No Holes to Dig
Perfect for DIY Projects

**Professional Builders
Choose Diamond Pier**

**Uplift & Lateral
Resistance
Increased
Dramatically**

**Inclined
Pin Pile Design
Distributes Loads
Over a**

**Greater
Bearing Area**
than Conventional Concrete
Footings

**Uplift & Lateral
Resistance
Increased
Dramatically**

**Code
COMPLIANT**
MODELS
**DP-50
AND DP-75**

**GreenSpec®
LISTED**

DiamondPier®

FOUNDATION SYSTEM

INSTALLATION MANUAL

Pin Foundations, Inc.

Gig Harbor, Washington

Toll Free: 866-255-9478 / Main Office: 253-858-8809

www.pinfoundations.com or www.diamondpiers.com

© 2020 by Pin Foundations, Inc. All rights reserved. DOC0001/0.2020

Diamond Pier® Foundation Systems are covered by U.S. Patents 5,039,256; 6,910,832; 7,326,003; and patents pending.

Diamond Pier® is a U.S. registered trademark of Pin Foundations, Inc.

The latest version of this Installation Manual is available on our website, www.diamondpiers.com, or by calling us at 866-255-9478 (Toll Free) or 253-858-8809 (Main Office).

Other documents and publications referenced in this manual are listed below and available at www.diamondpiers.com.

National Evaluations

“Diamond Pier DP-50 & DP-75 for Bearing Pin Piers,” ICC-ES Evaluation Report No. ESR-1895, 2017.

State Evaluations

“Diamond Pier DP-50 & DP-75 Precast Concrete Pier Foundation Assembly,” Wisconsin Building Product Evaluation, Code Approval No. 201612-O (Replaces No. 201008-O), November 22, 2016.

Observational Evidence

“Diamond Pier National Performance Submittals,” 2005.

“Diamond Pier Frost Performance Report, Zone II, Minnesota Soils,” 2010. “Diamond Pier Observational Evidence, Forest Lake, Minnesota,” May 2011.

PFI Frost Performance Study 2109

Building Code Compliance Documents

“Code Compliance Information for Diamond Pier Foundations in the State of Michigan,” Pin Foundations, Inc., Revised January 2018.

“Code Compliance Information for Diamond Pier Foundations in the State of Minnesota,” Pin Foundations, Inc., Revised January 2018.

CONTENTS

INTRODUCTION	4
Soils	4
Pin Pile Technology	4
Diamond Pier Foundation System.....	4
CONDITIONS AND USES	5
Normal Soil Conditions	5
Supporting Soils	5
Residential Diamond Pier Load Chart.....	6
Use and Applications	7
Frost Heave	7
Heave Resistance.....	7
INSTALLATION INSTRUCTIONS	8
Prior to Installation	8
Inspect for Underground Obstacles	8
Locate Buried Utilities.....	8
Check Your Layout.....	9
Assemble Tools and Supplies.....	10
Inspect and Prepare Diamond Pier Components	10
Install Inspection Plugs in Pins.....	11
Installation.....	11
Identify and Mark Location	11
Set the Concrete Head.....	11
Drive in the Pins	12
Encountering Obstructions.....	13
Removing Pins	13
Place Pin Caps on Pins.....	14
Register Your Product Warranty.....	14
AUXILIARY PARTS AND EQUIPMENT	15
Post/Beam Brackets	15
Breaker Hammers and Driving Bits	15
FIELD INSPECTION	16
Pin Length Inspection	16
Pin Specifications	16
Concrete Head Integrity.....	16
Allowable Capacity	17
SPECIFICATIONS	18
References/Standards	18
Delivery/Storage and Handling.....	18
Pins	18
Connections/Posts/Beams	18
Site.....	18
Installation.....	18
TROUBLESHOOTING	19

INTRODUCTION

Soils

Pin Foundations, Inc. (PFI) has been designing and manufacturing foundations for over 25 years. One thing has always driven our thinking—the Earth is the actual foundation, and soils, in their natural undisturbed state, have the strength and structure to do the job.

Man-made foundations have two basic functions: to transfer loads properly into the Earth's soil structure and to provide a connection to the built structure above. There are two general types of man-made foundations: deep vertical pilings (banged in) and shallow spread footings (dug in and buried). Pilings keep the Earth's existing soil strength and structure intact, and are easy to install if they do not need to go too deep. Footings spread loads more widely, but the digging breaks apart the soil, weakening it and blocking or exaggerating water flow.

Pin Pile Technology

Pin pile technology combines the best features of both types of man-made foundations. By grouping short stiff piles (bearing pins), which can easily be driven into intact penetrable soils, and setting them at angles to work more like a shallow footing, a sound foundation can be constructed that requires no excavation. The pin pile group simulates nature's design, resembling the roots of a tree providing bearing, uplift, and lateral capacity. In recent decades, grouped pin piling has become a reliable technology for complex, heavy-duty commercial applications, performing a superior job of transferring loads to intact undisturbed soils.

Diamond Pier Foundation System

PFI's innovation is to bring pin pile technology into common use with a superior connector—the Diamond Pier concrete head. This high-strength, precast component is a driving guide, a pin piling lock, and a structural connection all in one. As a driving guide, the head maintains the pin angles so that their capacity is definable and consistent. As a lock, the head is designed to increase its grip on the pin cluster when loaded up, down, or sideways—getting stronger and tighter as loads increase. And as a connection, an embedded anchor bolt and precast, post-matching shape make it a simple and proportional complement to its supported structure.

This concrete head combined with the bearing pin group forms the Diamond Pier system—a hybrid of familiar concrete and steel materials. This system provides a solid, stable, economical foundation that both captures and preserves the supporting strength and natural functions of the Earth's soil it's engaged in and, in turn, solidly and simply connects to and protects the permanent structures above.

This manual provides information and instructions for installing Diamond Pier foundations in residential applications in Normal Soil Conditions (see next section).

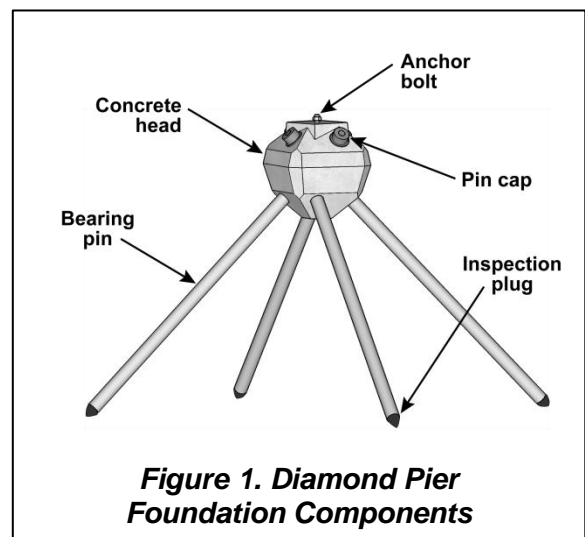

CONDITIONS AND USES

Normal Soil Conditions

Diamond Pier foundations sold through retail outlets are designed for projects that are founded in normal sound soils. Normal soils are typical in most residential neighborhoods throughout the United States and are defined in the International Residential Code (IRC) Table R401.4.1. Presumptive Load-Bearing Values of Foundation Materials.

For residential applications, the two most common prescriptive bearing soil types relied upon in the IRC table, and in most local codes, are 2000 psf sands/gravels and 1500 psf silts/clays. Diamond Pier foundations sold through retail outlets must be founded in soils with a minimum 1500 psf bearing strength. Supporting soils that do not meet the presumptive bearing strength defined in the applicable code for your area will not provide expected foundation capacity, and their bearing capacity may need to be determined by a soils investigation. Ask your local code official for soil information regarding your site. Additional soils information may also be available at the U.S. Geological Soils Survey website managed by the U.S. Department of Agriculture—see <http://websoilsurvey.sc.egov.usda.gov/>.

Supporting Soils

Some soils may not be appropriate for supporting Diamond Pier foundations. Some examples include soils that are weaker than 1500 psf, soils that are highly expansive, shifting or sliding soils, soils on slopes greater than 2:1 (27 degrees), contaminated soils, or soils where traditional concrete piers, accepted by local codes, are unable to provide adequate bearing to support the loads of the project or to protect the structure from the negative effects of frost heave. Where unsound soils exist, a registered design professional may be required to review the project.

Soils can also be weakened when they retain standing water or are improperly drained, and in certain types of soil this can also cause heave problems. A site depression with standing water or the potential for water to pond, pool, or saturate the soil may be an indication that the soil is not sound. Downspouts that discharge at or near a foundation may also cause soil problems, and setting a Diamond Pier foundation adjacent to any water body should be considered carefully. Depending on the variables involved, soils at the edge of or within lakes, ponds, rivers, streams, or tidal zones may be considerably weaker (as much as 40% or more) than dry or well-drained soils. Soils adjacent to existing foundations may also have been improperly or loosely backfilled, which may also cause poor drainage or poor soil conditions. Be sure to inform your project designer if any of these conditions exist.

Please contact PFI if you have any questions regarding your project or soil conditions, and/or the proper use of the Diamond Pier product or “Residential Diamond Pier Load Chart,” provided in Table 1.

WARNING: You must check for underground utilities and follow the instructions described under “Locate Buried Utilities” (page 8) before Diamond Pier foundations can be installed.

Residential Diamond Pier Load Chart

Table 1. Residential Diamond Pier Load Chart
IAS-Accredited Third-Party Bearing, Uplift, and Lateral Field Tests²

Minimum 1500 psf Silts/Clays (CL, ML, MH, CH)³

Model / Pin Length	Bearing Load Capacity	□ Equivalent Base Area	○ Cylinder Comparison	☼ Frost Zone	Uplift Load Capacity	Lateral Load Capacity
DP-50/36"	2700#	1.8 sf	18" dia	24"	600#	600#
DP-50/42"	* 3000#	2.0 sf	19" dia	36"	* 900#	* 600#
DP-50/50"	3300#	2.2 sf	20" dia	48"	1200#	600#
DP-75/50"	* 3750#	2.5 sf	21" dia	48"	* 1400#	* 600#
DP-75/63"	4200#	2.8 sf	22" dia	60"	1600#	600#
Equivalency to Traditional Concrete Footings						

Minimum 2000 psf Sands/Gravels (SW, SP, SM, SC, GM, GC)³

Model / Pin Length	Bearing Load Capacity	□ Equivalent Base Area	○ Cylinder Comparison	☼ Frost Zone	Uplift Load Capacity	Lateral Load Capacity
DP-50/36"	3600#	1.8 sf	18" dia	24"	600#	600#
DP-50/42"	* 4000#	2.0 sf	19" dia	36"	* 900#	* 600#
DP-50/50"	4400#	2.2 sf	20" dia	48"	1200#	600#
DP-75/50"	* 5600#	2.8 sf	22" dia	48"	* 1400#	* 600#
DP-75/63"	6400#	3.2 sf	24" dia	60"	1600#	600#
Equivalency to Traditional Concrete Footings					*Interpolated from field test values.	

Notes:

1. This load chart is intended for simple structures supported by columns, posts, and beams loaded up to, but not exceeding, the stated capacities. It is not intended for structures with asymmetrical, rotational, overturning, or dynamic forces. Intended uses are described in section 2.0 of ICC-ES prescriptive bearing evaluation report ESR-1895. For projects that exceed the capacities or limitations defined herein, or the intended uses described in ESR-1895, contact PFI for additional information or site-specific capacity evaluation. See also the [Use and Applications](#) download at www.diamondpiers.com.
2. Capacities shown are tested to a Factor of Safety of 2, and are applicable in properly drained, normal sound soils only, with minimum soil bearing capacities as indicated. Copies of the field test reports are available from PFI upon request.
3. See IRC Table R401.4.1, "Presumptive Load-Bearing Values of Foundation Materials," for a full description of applicable 1500 psf and 2000 psf soil types. For soils below 1500 psf, or soils with unknown characteristics, additional site and design analysis is required. For soils above 2000 psf, the values in this chart shall apply.
4. All capacities use four pins of the specified length per foundation. Pin length includes that portion of the pin embedded within the concrete head. See "Check Your Layout" on page 9 for more information on pin/pier layout and spacing restrictions.
5. For professional engineers designing for short-term transient loads, contact PFI for further information.

Use and Applications

The intended use for Diamond Pier DP-50 and DP-75 foundations sold through retail stores is to support simple residential projects constructed with columns, posts, and beams. The scope of project is defined as decks, covered decks, walkways, stairways, and accessory structures or similar projects that meet this intent. Project loads are limited to the capacities defined in the “Residential Diamond Pier Load Chart” shown in Table 1. The load chart shows that Diamond Pier foundations provide equal or better performance when compared to traditional concrete foundations claimed as equivalent.

In the residential load chart, “cylinder comparison” and “frost zone” values are given. These two values define the size of the traditional concrete pier foundation that a given Diamond Pier foundation is equivalent to in bearing capacity and frost heave resistance. For example, a DP-50 with 50" bearing pins shows a cylinder comparison of 20" and a frost zone rating of 48". This compares with a traditional 20" diameter, 48" deep poured concrete foundation. For more information, please refer to the [Use and Applications](#) document at www.diamondpiers.com.

Frost Heave

Frost is not an unusual or unsound soil condition unless the site has a history of locally accepted conventional foundations failing due to frost heave or freeze/thaw cycling. In frost zones, a properly drained, sound soil will freeze solid and hold its foundations tight. In heaving areas, water sources, the rate of temperature drop, and certain soil grain sizes can combine to cause pressures on foundations in all directions. The most important of these three factors is the presence of water in the soil, and this makes proper drainage a must—for all types of foundations.

Heave Resistance

Most traditional concrete foundations in frost zones rely on depth and gross weight as protections against frost heave. They use significant volumes of site-poured concrete, which has the potential for many field condition variables and inconsistent mix designs, and their installation requires considerable excavation, which weakens the existing soil structure, invites water problems, and leaves substantial amounts of soil to be removed from a site.

Diamond Pier foundations resist heave pressures and are often used in areas requiring frost protection.

Rather than reaching a specific vertical depth or gross weight, Diamond Pier foundations resist heave pressures with their wide-spreading pin pile groups. Embedded in the intact soil structure, the pins are prevented from changing angle under load by the concrete head, creating a stable foundation for both bearing and uplift forces. Because of the unique design of the Diamond Pier head, the pins are also free to move along their axes without compromising the position of the head or its lock on the pin cluster. This feature allows the Diamond Pier foundation to absorb soil strains caused by frost heave or expansive conditions without losing alignment or transferring these strains to the supported structure.

When assessing projects in extreme frost areas, be aware of sites where traditional concrete footings—48" to 60" deep—have failed to resist frost heave, requiring larger, deeper concrete piers. Project sites that require concrete footings deeper than 60" to resist frost heave exceed the definition of normal soil conditions and the limits of the “Residential Diamond Pier Load Chart.”

INSTALLATION INSTRUCTIONS

These instructions only cover the installation of Diamond Pier foundations in residential applications where normal soil conditions exist and the “Residential Diamond Pier Load Chart” (Table 1) is referenced (see discussion of “Normal Soil Conditions” on page 5 and “Residential Diamond Pier Load Chart” on page 6).

Please also view the “Installation” video provided on our website, www.diamondpiers.com.

Prior to Installation

Inspect for Underground Obstacles

The same obstacles that conventional foundation systems encounter, such as rocks, tree roots, underground utility lines, and other buried objects, can also obstruct the Diamond Pier system. Refer to “Encountering Obstructions” (page 13) for instructions on handling buried obstacles. If an obstacle is encountered that cannot be passed using the breaker hammer while driving the pins and not cracking the concrete pier head in the process, the pins can be removed and the concrete head rotated, allowing the pins to penetrate the soil in a different location.

Locate Buried Utilities

WARNING: Do not install Diamond Pier foundations before all underground utilities have been located, marked, and de-energized.

All underground utility lines must be located and properly marked by your local official utility locating service, and all privately run lines must also be identified and located by the proper authority. If there are any electrical lines in the area, de-energize the power source prior to installing the Diamond Pier foundations. Never allow bodily contact with uninsulated portions of the automatic breaker hammer. Wear properly rated rubber-insulated gloves and boots. In addition, if underground utilities are located on the site, check with your local utility locating service to confirm required safety zones. You must ensure that the horizontal pin distance for your foundation will have adequate horizontal clearance to be well outside all safety zones, including the 6" Diamond Pier (DP) safety zone (see Figure 2 and Table 2 on next page).

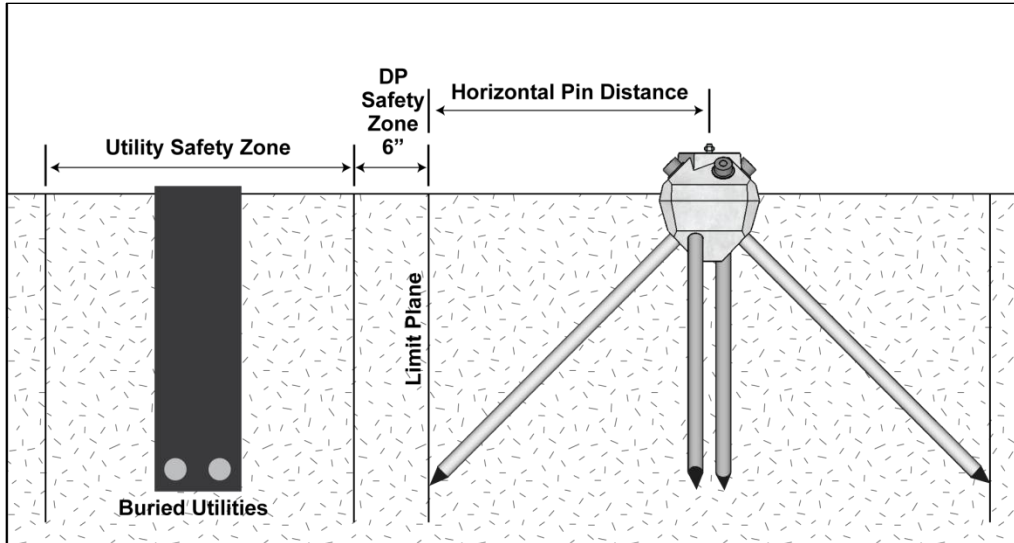

Figure 2. Horizontal Pin Distance

After installation, horizontal distance of all pins must be well outside all safety zones.

Table 2. Horizontal Pin Distance for All Diamond Pier Models

Measured from center of pier anchor bolt horizontally to vertical limit of pin end.

Pin Length (inches)	Horizontal Pin Distance (inches)	
	When Pin Is at 90 degrees (Perpendicular to Limit Plane)	When Pin Is at 45 degrees (Shortest Distance to Limit Plane)
36	20	15
42	24	17
50	29	21
63	38	27
84	51	36
126	78	56

Check Your Layout

To meet the load bearing capacities shown in the “Residential Diamond Pier Load Chart” (Table 1, page 6), Diamond Pier foundations must be spaced a minimum of 3 feet apart (from center of pier anchor bolt to center of pier anchor bolt). If they are spaced less than 3 feet apart, the bearing capacity must be reduced by 13% for each closer-spaced pier. The piers must also be set back the correct horizontal distance from existing foundations or other buried obstacles, as shown in Table 2. Tributary loads from the supported structure must be properly calculated, and the piers spaced accordingly, so that each pier is supporting only up to its designated allowable loads.

Assemble Tools and Supplies

You will need to assemble the following tools and gear:

- Automatic driving hammer with 1-1/8" hex shaft driving bit (see "Breaker Hammers and Driving Bits," page 15)
- Square-edge shovel
- Sledgehammer
- Torpedo level
- Tape measure
- Pipe wrench
- Proper protective gear, including safety goggles, ear protection, insulated gloves, protective clothing, and boots

We recommend a minimum two-person crew for installation.

Inspect and Prepare Diamond Pier Components

Inspect your Diamond Pier assemblies (see Figure 3) to ensure that no parts are flawed or have been damaged in shipping. Do not install a concrete pier if it has a structural crack with a fissure running internally into the head (see "Concrete Head Integrity" on page 16). Slight flaking or chipping is acceptable; a concrete head with surface flaking or chipping may be installed.

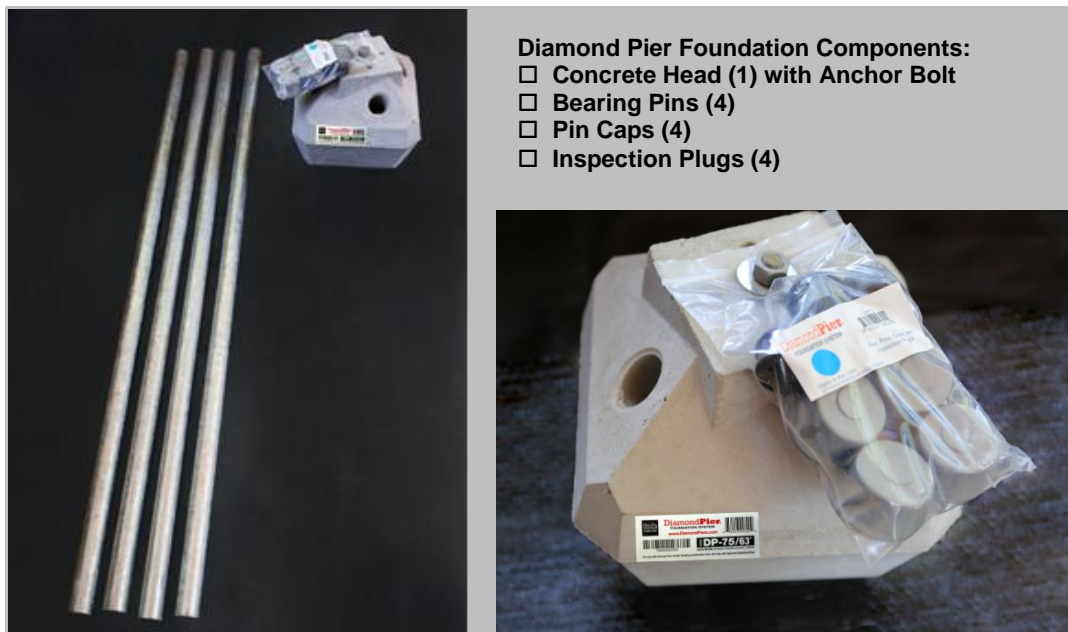

Figure 3. Diamond Pier Model DP-75/63" – Concrete Head with Bearing Pins and Package Containing Pin Caps and Inspection Plugs

Verify that you have the correct number of concrete heads with the corresponding number of bearing pins (4 per pier), pin caps (4 per pier), and inspection plugs (4 per pier), and that the anchor nuts thread properly on the pier anchor bolts. Measure the pin diameter to be sure the proper pins have been supplied for your pier model. (The DP-50 model has a 1" nominal pin with a 1.315" actual outside diameter [OD]; DP-75 has a 1-1/4" nominal pin with a 1.67" actual OD.) If the pins do not fit, contact your supplier. The inspection plugs are inserted in the bottom of each bearing pin prior to installation to keep soil from moving up inside the pins as they are driven into the ground. This allows inspectors to slide a tape measure down a pin from above as a method to verify its length.

Install Inspection Plugs in Pins

Remove any dirt and debris from the pins and check that they will fit easily into the driving holes in the concrete heads. (If a cut or burr is restricting the fit, try the other end of the pin.)

Install the inspection plugs in the ends of the pins that will go into the concrete head first. Align the slot in the plug with the interior weld bead and insert (see Figure 4). The allowable tolerance in pin wall thickness means that some plugs will fit high in the end of the pin, and some will fit down almost to the plug shoulder. In either case, tap the point of the plug with a hammer to seat it firmly enough in the end of the pin so that it will not drop out as you slide it through the driving holes in the pier. Don't worry that tapping the end of the plug with the hammer will blunt the point; it is not intended as a piercing or cutting tip, and this will happen anyway as the plug is driven into the soil. (See "Encountering Obstructions," page 13, for plug use where buried obstructions may be encountered.)

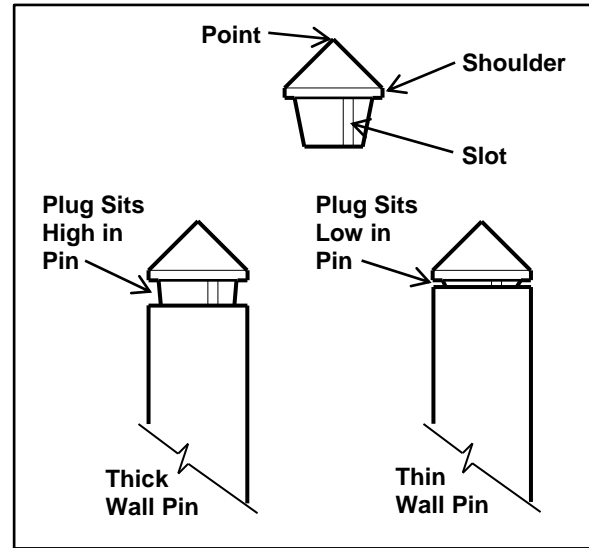

Figure 4. Inspection Plugs Must Be Installed in Pins

Installation

Identify and Mark Location

1. Identify where you would like the center of the pier anchor bolt to be located.
2. Mark the location by using reference points that will easily identify the center location of the pier even after top soil is removed. **Tip:** Set a string line centered on the anchor bolt approximately 12-14" above the ground for a quick reference point and to maintain alignment.

Set the Concrete Head

1. Dig a tapered square hole the same size and shape as the bottom half of the concrete head (see Figure 5). This creates a cradle to steady the head for leveling. Soils directly below the head should be left loose.
2. *Following safe lifting procedures*, carefully lift the concrete head and position it in the hole to its midpoint.* Ensure top is level and centered on your alignment.
3. Replace some of the removed soils back around the sides of the head at grade, lightly tamping to maintain level and alignment during pin driving. (See Notes under "Drive in the Pins" on page 12.) A few inches of small rounded pea gravel may be used if native soils are not available.



Figure 5. Tapered Hole for Concrete Head

NOTE: The edges of the top of the concrete head do not have to align exactly with the sides of the post or post bracket as long as the bracket being used is fully supported by the concrete and providing proper weight distribution.

*The concrete head may also be buried for aesthetic considerations, but access to the top of the head needs to be maintained. Concrete slabs, patios, and other products installed **MUST NOT** interfere with the Diamond Pier foundation and the attached post/beam assembly. Expansion joints may be used to protect the foundation. Proper drainage must also be maintained.

Drive in the Pins

WARNING: Verify locations of any buried utilities before driving pins (see “Locate Buried Utilities,” page 8).

1. Slide the ends of the pins with the inspection plugs through opposing holes in the concrete head, making sure to support them so their weight does not roll the head out of the hole or out of alignment.
2. Keeping the pin centered in the driving hole, carefully set each pin 6" to 12" into the soil tapping with the sledgehammer (gripped just below the hammer head) until the concrete head is locked into a level position (see Figure 6). Impact the pin end squarely to minimize flaking of the concrete surface or deformation of the end of the pin (see **Note 1**).
3. With the pin driving bit installed on the automatic hammer, and another crew member holding the pin, drive in opposing pins alternately in increments (see **Note 2**). Periodically check for alignment and level (a 5-degree tolerance is allowed). Be sure to keep the weight of the auto-hammer from forcing the pin against the lower half of the driving hole and impacting the concrete head. The other crew member should hold the pin centered in the driving hole (see Figure 7). This will also reduce pin vibration and minimize concrete flaking.



Figure 6. Setting Pins and Leveling Concrete Head

NOTE: Do not use the pin driving bit as a hammering tool or hammer against it with the sledgehammer. It is to be used with the automatic hammer only.

4. Temporarily drive all pins down to within 6" from the top of the head; this allows easier removal if an obstruction is encountered (see **Note 3**).
5. Finish driving the pins with the automatic hammer (with pin driving bit), being careful not to damage the precast concrete head or the upper ends of the pins and leaving approximately 3/4" of the pin protruding from the top of the concrete.



Figure 7. Driving Pins with Auto-hammer and Pin Driving Bit

Note 1: Do not attempt to drive the pins all the way down with just the sledgehammer; this may damage the ends of the pins or crack the concrete head.

Note 2: Do not drive a pin all the way down at once as this may cause the head to be pulled to one side. Continue to rotate around the head, driving the pins in increments, until the growing strength in the pile group is sufficient to allow final driving.

Note 3: Do not continue to hammer away at a pin that is bouncing, rattling, or scraping against an impassable object. This may cause the concrete head to ride up the pin, push the head to one side, or risk eccentrically stressing the head with a pin that is out of line. It could also cause the concrete head to have a structural crack, which would require removal and replacement (see “Concrete Head Integrity” on page 16). If encountering difficulties in the soil, see “Encountering Obstructions” on the next page.

Encountering Obstructions

If a pin stops moving when being driven in, STOP driving the pin. If the obstruction is close enough to the surface, it may be dug up and removed. Once accomplished, recompact the soils with the sledgehammer, and then reset the concrete head.

You can also try to drive the pin past or through the obstruction. Be sure the other pins are at least half way in to stabilize the concrete head and ensure that the head will remain in place before trying to drive the obstructed pin in any further. Put a pencil mark on the pin by the head to indicate if the pin moves. Attempt to drive the obstructed pin with the automatic hammer for approximately 10 to 20 seconds, or give it one or two firm square hits with the sledgehammer, which may drive it past the obstruction. Many small rocks will roll, potentially allowing the pin to move directly past. If the pin begins to move, continue with the automatic hammer, but make sure that it is not being forced out of line. If its trajectory is off, this can cause an eccentric stress on the concrete head and crack it.

If you can remove the pin, you can try removing the soil plug and redriving. Inspection plugs may only be omitted when approved by the building official. With the plug removed and less surface area at the lower end, the pin may drive easier, and not be forced by the angle of the plug past an obstruction, but off its trajectory.

If the trajectory is off or the pin will not go in at all, remove all the pins (see “Removing Pins”), rotate the concrete head around its center alignment, and reinstall to avoid the obstruction. The pier may also be relocated, within the parameters of your structure’s design, if necessary.

Removing Pins

The jacking method is used to spin and pry a pin out from the concrete head simultaneously by using a pipe wrench and a pry bar. This method works best when the pin is approximately 6" extended out from the concrete head. A pipe wrench, a flat bar, and a pry bar are required. Follow the instructions below to turn the pin while corkscrewing it upward. See also the “Pin Removal” video on the website.

1. Using your right hand, place the pry bar flat against the concrete angle at the outer edge of the pier head and perpendicular to the pin to be removed.
2. With your left hand, place the pipe wrench on the pin and slide it down tight to the pry bar. The pipe wrench handle should be pointing up slightly and perpendicular to the pry bar to allow the pipe wrench to turn the pin as it is pried (see Figure 8).
3. Pull up on the pipe wrench handle to lock.
4. Pull up on the pry bar with your right hand to move the pin out approximately 1" to 2".
5. Slide the pry bar back to be flush with the concrete angle on the pier head.
6. Repeat lock and jack (steps 3–5) until the pin can be pulled out by hand.



Figure 8. Jacking Method for Pin Removal

Note 1: For the first 4" of removal use the flat bar with the pipe wrench. After the pin is 4" removed you may use a pin as a pry bar.

Note 2: For an alternate removal technique, an internal pipe locking tool with an electric impact wrench may be used to spin the pin and draw it from the concrete head.

Place Pin Caps on Pins

1. Set the pin caps loosely on the ends of the pins so they can be removed for pin length inspection (see “Pin Length Inspection,” page 16).
2. Set brackets and posts or beams, and frame and complete the supported structure.
3. Once these framing material loads have been applied, pull the caps off and reverify the extent of the protruding pins, adjusting as necessary by tapping with the small sledgehammer.
4. After the field inspection has been completed, tap the caps down tight with the small hammer (see Figure 9) to seal them against the concrete.



Figure 9. Completed Installation with Pin Caps

NOTE: If the caps will not go on, check the pin ends for any extreme deformations that may have occurred while driving. File or grind off any damage to re-establish the original diameter, and apply the cap.

Register Your Product Warranty

1. Download the Limited Lifetime Warranty Application Form available at www.diamondpiers.com.
2. Submit application within 30 days of project completion.
3. Confirm receipt of your registered warranty by PFI.

AUXILIARY PARTS AND EQUIPMENT

Post/Beam Brackets

The bracket needed to make the connection from the Diamond Pier foundation to the superstructure can be purchased separately from a local lumberyard. The DP-50 pier typically has a 1/2" diameter galvanized bolt embedded in the top of the concrete head (nut provided), and this bolt will connect to a code-approved post base. The DP-75 pier has a 5/8" diameter bolt at the top of the concrete head. Check your local building code or building official to verify which post bases are acceptable in your area, and make sure to match the post size and loads on the post with the appropriate bracket size and bracket load ratings. Typically these brackets come with a "standoff" design that separates the wood from contact with the base of the bracket and eliminates the need to drill into the bottom of the lumber to compensate for the raised anchor bolt. Most post-base brackets have a wide hole in the base that allows for horizontal adjustment of the final bracket location.

Horizontal beams may also be set directly in an appropriate bracket for direct connection to the Diamond Pier foundation when constructing low-profile structures. Larger piers not shown on the "Residential Diamond Pier Load Chart" (Table 1) have a variety of bolt diameters and configurations. Contact PFI for more information if your project requires piers larger than the DP-50 or DP-75.

The proper bracket coating or finish should be chosen based on the lumber to be used and the treating specifications of the project superstructure. If stainless steel is chosen, the embedded galvanized bolt must be protected from contact with the stainless bracket with the addition of a plastic or rubber bushing (not supplied) or the concrete heads must be special ordered with embedded stainless steel anchor bolts to avoid the potential for corrosion of dissimilar metals in contact.

Breaker Hammers and Driving Bits

The Diamond Pier driving bit is recommended for use with a standard breaker/demolition hammer, see below. The driving bit has a 1-1/8" hex shaft, and can be rented or purchased through a local dealer or purchased directly from PFI. **NOTE: The bits are NOT to be used with, or as, a sledgehammer.**

Only automatic breaker/demolition hammers should be used to install the Diamond Pier pins. Any standard automatic hammer that will handle a 1-1/8" hex shaft can be used, provided it can be properly and safely controlled by the operator and not risk injury or damage to the concrete head. Soft or loose soils will allow for the use of lighter lower-energy hammers. Stiff or dense soils will require electric hammers in the higher impact range or standard jackhammers driven by compressed air. In most cases, the DP-50 and DP-75 are installed with electric hammers. Roto-hammers are not adequate.

Below is a list of commonly available electric automatic breaker/demolition hammers.

- BOSCH Brute #BH2760VC 63-lb Breaker Hammer; Bit type: 1-1/8" Hex
- MAKITA Model #HM1307CB 35-lb Demolition Hammer; Bit type: 1-1/8" Hex
- HITACHI Model #H65SD2 40-lb Demolition Hammer; Bit type: 1-1/8" Hex
- BOSCH Model #11335K 35-lb Breaker Hammer; Bit type: 1-1/8" Hex
- MILWAUKEE Model #5338 71-lb Breaker Hammer; Bit type: 1-1/8" Hex

FIELD INSPECTION

A Diamond Pier foundation code inspection may take place at any time during or after installation and may be combined with the structural framing inspection as each jurisdiction warrants. The top ends of all pins should be accessible for measuring pin lengths.

Pin Length Inspection

Diamond Pier foundations are designed to be inspected from above grade after they have been installed. An inspection plug must be installed at the lower (driven) end of the pin to keep soils from moving up inside it and to allow a tape measure to be slid down from the top of the installed pin to verify its length (see “Install Inspection Plugs in Pins” on page 11).

NOTE: The Diamond Pier foundation is a shallow bearing technology and does not require “refusal” or “friction” resistance, or the professional installation monitoring or special inspection typically associated with conventional vertical or battered piling.

NOTE: If framing members will be too close to the top of the concrete head to allow the tape measure to be inserted, then the inspection should be done before the framing is in place. Also, if inspection plugs have been unintentionally forgotten, then the pins can be twisted or jacked out with a pipe wrench to verify their length (see “Removing Pins” on page 13). They can then be redriven into the same soil cavity. If a plug has been removed to facilitate driving in an obstructed condition (see “Encountering Obstructions,” page 13), be sure to note or mark the location of this pin for the inspector. Pins are to be their full specified length without joints or coupling (length tolerance is $\pm 1/2$ ”).

Pin Specifications

Bearing pins provided with the piers are schedule 40 galvanized pipe, Grade A electric resistance welded, with no threads. This also can be verified from above grade; with the pin cap removed, the weld can be verified on the inside wall of the pin, and the wall thickness can be checked. If the wall thickness is thinner than specified, the pins have been substituted with a lower schedule pipe or conduit and must be replaced with the properly specified pipe—1" nominal schedule 40 pipe has a wall thickness of 0.133" (just over 1/8"), 1-1/4" nominal schedule 40 pipe has a wall thickness of 0.140". The wall thickness tolerance is $\pm 12\%$.

Concrete Head Integrity

If the “INSTALLATION INSTRUCTIONS” (page 8) are properly followed, the concrete heads should be level, and they should not have structural cracks as a result of improper handling or pin driving. (Surface spalls or chips may occur during driving or handling, but these are not structural, and will not affect the concrete head.) A structural crack is a fissure running internally into the head. It is perpendicular to the outer face of the head and runs inward to its core. This can weaken the strength of the pier head and/or allow water to penetrate and cause freeze/thaw problems in the concrete. If a concrete head has a structural crack, it should NOT be patched. It must be removed and replaced.

If a concrete head is more than 5 degrees out of level, the symmetry of the pin pairs may be compromised, and the head should be removed and correctly reinstalled.

Allowable Capacity

The piers must not be overloaded. The total load on any specific pier is based on the individual tributary loads of the structure, supported by the corresponding post or beam connected to the pier. If you are not capable of properly calculating allowable loads, have the loading and capacities verified by your local building department or an independent registered design professional.

The total load calculated for a post or beam connected to the pier (also known as the “support column”) is based on a combination of the live load (snow, people, furnishings, etc.) and the dead load (weight of structure itself). The live load and dead load requirements are provided by your local building department; loads are specified in pounds per square foot (psf). A determination must be made as to what portion of the floor area is supported by a single support column. A design professional should be able to make this determination. Once the proper area for the single support column is determined, multiply the area (A) supported by the required loads (in psf) to determine the total tributary load (in pounds) for the single pier:

$$(A) \times (\text{psf}) = \text{Total Tributary Load}$$

This value should not exceed the published capacity of the Diamond Pier model and corresponding pin length intended for use.

SPECIFICATIONS

The information given in this section is provided for use in document/permit submittal, where applicable.

References/Standards

ASTM A 53 - Pipe, Steel, Black and Hot dipped, Zinc-coated
ASTM A153 - Zinc coating (hot-dip) on Steel Hardware
ASTM, ACI, and CRSI standards for precast concrete products

Delivery/Storage and Handling

Contractor shall protect the materials from damage.

Pins

Four pins per pier. All pins to be galvanized steel pipe with butt cut ends, schedule 40, Grade A, Type E, electric resistance welded. Pins are to be capped with UV-resistant vinyl caps.

Connections/Posts/Beams

Diamond Pier foundation connection to be galvanized steel post base or beam bracket (by others) attached to embedded single galvanized anchor bolt in concrete head. See "Post/Beam Brackets" (page 15).

Site

Alteration of site soils or vegetation to be kept to a minimum to avoid erosion, drainage issues, or the need for replanting. Site must be properly drained.

Installation

Contractor shall verify superstructure layout, spans, and resulting loads for consistency with the manufacturer's published capacities.

Pins to be full length as specified before driving. No coupled or welded pins are to be used.

Follow the complete Installation Instructions provided in this manual.

TROUBLESHOOTING

Cracked Concrete Head	Always inspect materials when received from supplier. Do not install a head that has a structural crack or fissure running internally into it. Slight flaking or chipping does not constitute a crack.
Concrete Flaking	During installation, pins rubbing against the concrete head may cause superficial flaking of concrete around the driving hole. This will not affect the structural strength. However, if a structural crack or fissure running internally into the concrete head develops during installation, the integrity of the pier has been compromised and the concrete head must be removed and replaced.
Concrete Head Will Not Stay Level When Installing	One or more pins may be driving out of line due to obstructions in the soil (See “Encountering Obstructions,” page 13), or your hole for setting the concrete head may be too big. Only dig a hole the size of the head being used, and be sure to put all pins in the head before setting them. With all the pins sticking up from the head, one person can also push or pull on the pins to manipulate the leveling process and guide or steer the concrete head to a level position, being careful not to wrench on it and cause a crack.
Concrete Head Installed Out of Level	If a concrete head is more than 5 degrees out of level, the symmetry of the bearing pins may be compromised—the head should be removed and repositioned. Reinstall the pins incrementally at first, checking level constantly, and if one pin is not going in straight and is causing the head to tip, install the other pins first and then carefully finish driving this last pin.
Hitting an Obstruction When Installing	If an obstruction is encountered, the pins may be removed and the concrete head repositioned. If the obstruction is dug out and removed, soil must be recompacted per the Installation Instructions. See “Encountering Obstructions” (page 13).
Installing in Frozen Ground	Check with the local building code for criteria or limitations on installing foundations in frozen soil. See “Frost Heave” and “Heave Resistance” on page 7.
Pins Have Risen Slightly Out of the Concrete Head	This may occur when extreme loads have been applied to the pier, but the foundation is designed to relieve pressure in this way. The pins may simply be tapped back to their original position with a small hammer. Remove the caps, tap the pin, and replace the caps.
Pins Will Not Fit into Concrete Head	Make sure the pins fit into the concrete head before inserting the inspection plugs. Be sure pins and concrete heads are free of dirt, and check both ends of pins for fit. Always transport and store parts in a clean environment. Measure the pin diameter to be sure the proper pins have been supplied for your pier model. (The DP-50 model has a 1" nominal pin with a 1.315" actual outside diameter [OD]; DP-75 has a 1-1/4" nominal pin with a 1.67" actual OD.) If the pins still do not fit, contact your supplier.
Pin Caps Will Not Fit over Driven Pins	Check to be sure the proper cap size was supplied and that your caps are pliable and not frozen. Caps should be tapped on with a small hammer. If they still will not go on, check the pin ends for any extreme deformations that may have occurred while driving. File or grind off any damage to re-establish the original diameter, and apply the cap.

DiamondPier[®]

FOUNDATION SYSTEM

Pin Foundations, Inc.
Gig Harbor, Washington

Toll Free: 866-255-9478 / Main Office: 253-858-8809
www.pinfoundations.com or www.diamondpiers.com

© 2020 by Pin Foundations, Inc. All rights reserved. DOC0001/01.2020

**NISQUALLY STATE PARK
LEAD ASSESSMENT OF BORROW PIT**

Conducted On:

**NISQUALLY STATE PARK BORROW PIT
LATITUDE: 46.861251, LONGITUDE: -122.321474
MASHEL PRAIRIE ROAD
EATONVILLE, WASHINGTON 98328**

**MARCH 7, 2023
PROJECT NUMBER: 0223-03**

Prepared for:

**RWD | LANDSCAPE ARCHITECTS
BOB DROLL, PLA, ASLA, PRESIDENT
4405 7TH AVENUE SE, SUITE 203
LACEY, WA 98503
O: 360.456.3813 | C: 360.481.6479
BOB@RWDROLL.COM**

AND

**WASHINGTON STATE PARKS
1111 ISRAEL ROAD SW
TUMWATER, WA 98501-6512**



Prepared by:

ADESA, LLC
197 Central Avenue E
Tenino, WA 98589



Assessment Summary

ADESA has completed the preliminary lead assessment of a borrow pit located at approximate latitude: 46.861251 and longitude: -122.321474 within Nisqually State Park, Mashel Prairie Road, Eatonville, Washington 98328. The borrow pit is an approximately 1.58-acre (68,758.85 SF) portion of Pierce County Assessor Parcel Number 0416201006 (Subject Property/borrow pit). This assessment is being performed for RWD Landscape Architects and Washington State Parks to aid in the determination regarding the suitability of the material in the borrow pit for use as fill material.



Figure 1.0: Property Location Map

Based on the limited review of aerial photographs, it appears that the borrow pit was first developed circa 1970, possibly in conjunction with the adjoining former town of Eatonville Landfill site (Ecology Facility Site ID No. 85933) to the south beyond a narrow power utility corridor. Aerial photographs of the area suggest that the former landfill was in operation by 1955 or earlier. The landfill is currently undergoing remedial investigation to determine the extent of contaminate impacts to soil and groundwater by Weyerhaeuser and the town of Eatonville.

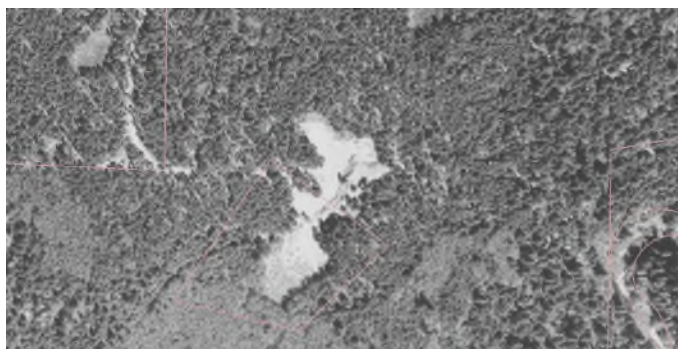

Gravel Pit and Adjacent Landfill Circa 1970



Prior sampling of the Subject Property occurred in 2021, when GSI Water Solutions, Inc., while performing a remedial investigation on the adjoining former landfill, collected and analyzed one 30-point composite sample of surficial soil from the borrow pit. The sample exhibited a concentration of lead at 6,000 mg/kg, well above the Washington State Department of Ecology MTCA Method A Cleanup Level in soil of 250 mg/kg. Based on the indications that the pit was historically used as a shooting range (spent shells/casings), it was suggested that this was the source of the lead. Elevated levels of lead have also been discovered in the surficial soil of the landfill. The GSI Water Solutions, Inc. results are provided in “Figure 9-2 Soil Analytical Results – ISM” (2021), which is attached in the Appendix.

Due to the similar historical and proposed uses of the Subject Property, the entire area was considered a single Decision Unit (DU).

Pursuant to an inquiry by RWD Landscape Architects, on February 20, 2023, ADESA established a 53 ft (northeast/southwest) by 64.25 ft (northwest/southeast) sampling grid over the 1.58 acre area (Decision Unit 1/DU1), and collected a total of 28 soil samples from grid locations at a depth of 6 inches below the surface (“s” samples collected from every location) and 12 inches below the surface (“d” samples collected from every 4th location). The soil samples were collected using clean, stainless steel hand tools and placed in labeled, laboratory supplied four-ounce glass jars with Teflon-lined lids. All of the soil samples were submitted, under chain of custody, to Libby Environmental Inc. for lead analysis by EPA Method 6020B. **Samples 9s and 18s were destroyed/broken by the laboratory and were consequently not analyzed as part of this assessment.**

The results of the sample analysis and sample location map are presented on the following pages. The results of the assessment are summarized below:

- The average lead concentration calculated for the entire DU was 107.8 mg/kg.
- Lead concentrations in excess of the Washington State Department of Ecology MTCA Method A Cleanup Level for Unrestricted Land Use (250 mg/kg) were detected in samples 8s, 8d and 20s.
- The greatest single lead concentration within the DU was 591.0 mg/kg in sample 20s.
- The lead concentrations discovered in the remaining samples within the DU were below the cleanup level established by Ecology.

Recommendations

Based on the findings of this assessment ADESA recommends additional sampling to further delineate and characterize the lead impacted areas. The Washington State Department of Ecology should be notified of the findings of this assessment.



Sample ID	Latitude	Longitude	Lead Concentration (mg/kg)	Location ID
1s	46.8612	-122.322	34.50	1
2s	46.8613	-122.322	17.40	2
3s	46.8614	-122.322	6.81	3
4s	46.8615	-122.322	10.90	4
4d	46.8615	-122.322	8.13	4
5s	46.8616	-122.321	6.25	5
6s	46.8615	-122.321	47.40	6
7s	46.8614	-122.322	49.20	7
8s	46.8613	-122.322	266.00	8
8d	46.8613	-122.322	258.00	8
9s	46.8612	-122.322	not analyzed	9
10s	46.8611	-122.322	17.40	10
11s	46.8610	-122.322	16.50	11
12s	46.8611	-122.322	36.00	12
12d	46.8611	-122.322	45.40	12
13s	46.8612	-122.321	190.00	13
14s	46.8613	-122.321	173.00	14
15s	46.8614	-122.321	192.00	15
16s	46.8615	-122.321	185.00	16
16d	46.8615	-122.321	61.00	16
17s	46.8614	-122.321	81.80	17
18s	46.8613	-122.321	not analyzed	18
19s	46.8612	-122.321	18.20	19
20s	46.8611	-122.321	591.00	20
20d	46.8611	-122.321	203.00	20
21s	46.8610	-122.321	25.50	21
22s	46.8610	-122.321	26.50	22
23s	46.8611	-122.321	235.00	23

Results depicted in red represent concentrations in excess of current state cleanup levels. The laboratory documentation is presented in the Appendix.





References

Pierce County Public GIS Online Property Information for Subject Property. March 2023.

Washington State Department of Ecology. 1995. Guidance on Sampling and Data Analysis Methods – Publication 94-49. January.

Washington State Department of Ecology. Washington Administrative Code 173-340, Washington State Model Toxics Control Act (MTCA). 2013.

Washington State Department of Ecology (WDOE). Washington State Everett and Tacoma Smelter Search Map. <https://fortress.wa.gov/ecy/smeltersearch/>. February 2023



**APPENDIX A
FIGURES**

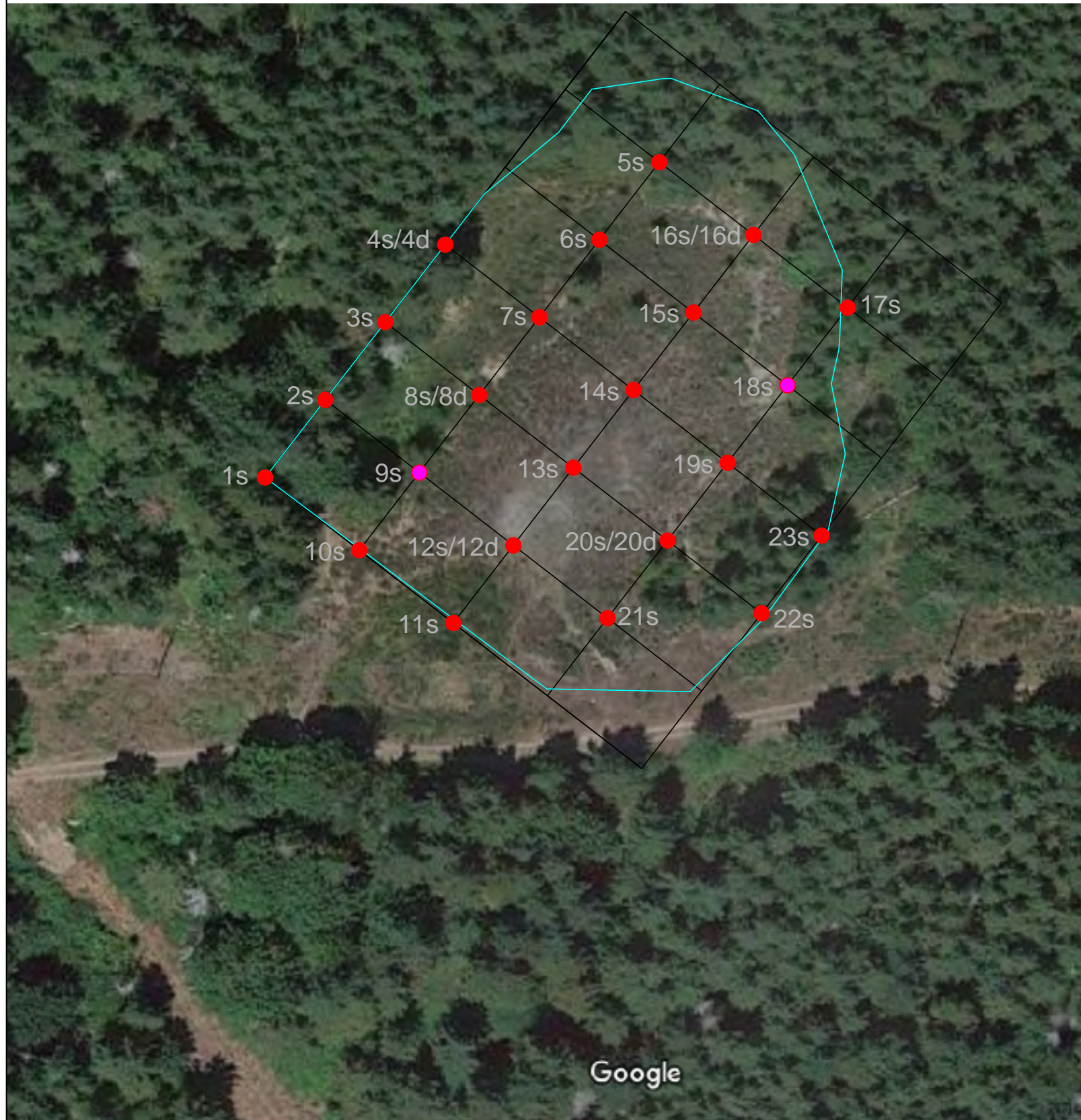

**Nisqually State Park Borrow Pit
Lead Assessment**

February 2023

ADESA Environmental
197 Central Avenue East
Tenino, Washington 98589

Sample Location
Map

FIGURE 9-2
Soil Analytical Results - ISM
(2021)
 Remedial Investigation
 Former Eatonville Landfill
 Eatonville, WA

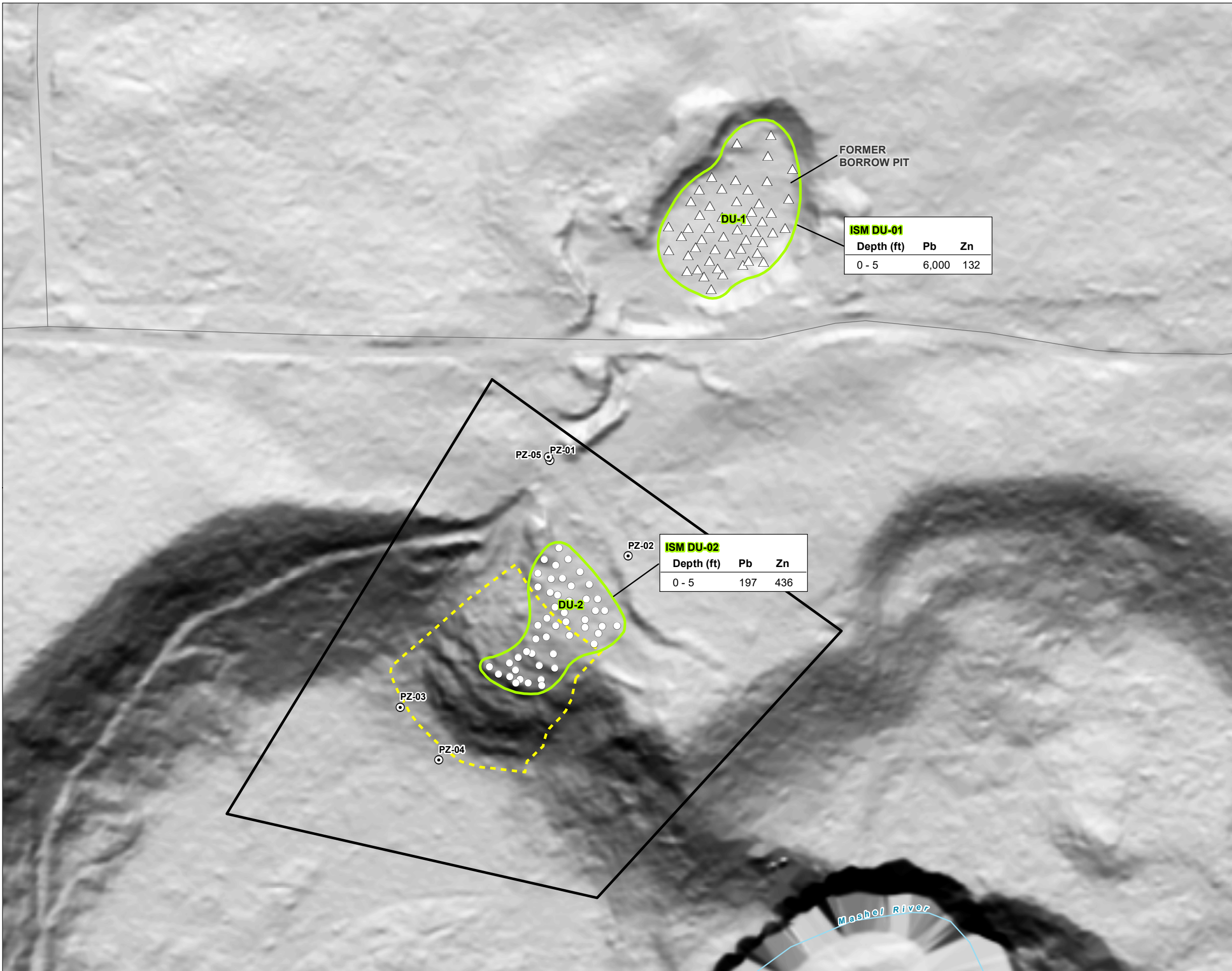

LEGEND

- Property Boundary
- Location of Former Landfill
- ISM Decision Unit Boundary
- Groundwater Monitoring Well
- ISM Sample Locations**
 - ISM DU-1 (Borrow Pit)
 - ISM DU-2 (Historic Landfill Cover)
- All Other Features**
 - Road
 - Watercourse

NOTES

1. Site features are approximate.
2. Results are shown in milligrams per kilogram.

Pb: Lead
 Zn: Zinc

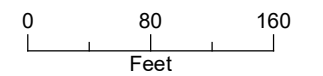
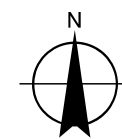

Date: February 8, 2022
 Data Sources: USGS, ESRI, DNR (2011),
 Pierce Co.





**APPENDIX B
LABORATORY DOCUMENTATION**



Libby Environmental, Inc.

3322 South Bay Road NE • Olympia, WA 98506-2957

March 3, 2023

William Rutherford
ADESA
P.O. Box 1009
Tenino, WA 98589

Dear William Rutherford:

Please find enclosed the analytical data report for the NSP – Gravel Pit project located in Eatonville, Washington.

The results of the analyses are summarized in the attached tables. Applicable detection limits and QA/QC data are included. The sample(s) will be disposed of within 30 days unless we are contacted to arrange long term storage.

Libby Environmental, Inc. appreciates the opportunity to have provided analytical services for this project. If you have any further questions about the data report, please give me a call. It was a pleasure working with you on this project, and we are looking forward to the next opportunity to work together.

Sincerely,

Sherry L. Chilcutt
Senior Chemist
Libby Environmental, Inc.

Libby Environmental, Inc.

Chain of Custody Record

www.LibbyEnvironmental.com

3322 South Bay Road NE
 Olympia, WA 98506
 Ph: 360-352-2110
 Fax: 360-352-4154

Client: **ADESA**

Address: **197 Central Ave E**

City: **Tenino** State: **WA** Zip: **98589**

Phone: **360-201-8797** Fax:

Client Project # **0223-03**

Date: **2/21/2023** Page: **1** of **2**

Project Manager: **WW Rutherford**

Project Name: **NSP - Gravel Pit**

Location: **Eatonville - NSP** City, State: **Eatonville, WA**

Collector: **WW Rutherford** Date of Collection: **2/20/2023**

Email: **wutherford@adesa-wa.com**

Sample Number	Depth	Time	Sample Type	Container Type	VOC 8260	PCE & Daughter Prod.	NWTPH-Gx	BTEX (8260) / (8021)	NWTPH-HCID	NWTPH-Dx / Dx	PCB 8082	MTCA 5 Metals	RCRA 8 Metals	PAH 8270	Semi Vol 8270	Lead 6010, 6020	or 6200 per Ecology	Field Notes
1	1s	0-6in		4oz												X		
2	2s	0-6in														X		
3	3s	↓														X		
4	4s	↓														X		
5	4d	6-12in														X		
6	5s	0-6in														X		
7	6s	↓														X		
8	7s	↓														X		
9	8s	↓														X		
10	8d	6-12in														X		
11	9s	0-6in														X		Unable to perform analysis
12	10s	↓														X		sample container broke
13	11s	↓														X		at subcontracted lab.
14	12s	↓														X		
15	12d	6-12in														X		
16	13s	0-6in														X		
17	14s	↓														X		

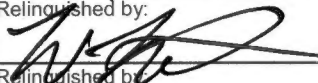
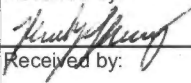
Relinquished by: 	Date / Time: 2/21/23	Received by: 	Date / Time: 2.21.23 1218	Sample Receipt		Remarks:
Relinquished by:	Date / Time:	Received by:	Date / Time:	Good Condition?	Y N	
				Cooler Temp.	°C	
				Sample Temp.	°C	
Relinquished by:	Date / Time:	Received by:	Date / Time:	Total Number of Containers		

TAT: 24HR 48HR 5-DAY

Libby Environmental, Inc.

Chain of Custody Record

www.LibbyEnvironmental.com

3322 South Bay Road NE
Olympia, WA 98506

Ph: 360-352-2110
Fax: 360-352-4154

Date: 2/21/23 Page: 2 of 2

Client: ADESA

Project Manager: WW Rutherford

Address: 197 Central Ave E

Project Name: NSP - Gravel Pit

City: Tenino State: WA Zip: 98509

Location: Eatonville - NSP City, State: Eatonville, WA

Phone: 360-701-8797 Fax:

Collector: WW Rutherford Date of Collection: 2/20/2023

Client Project # 0223-03

Email: wutherford@adesa-wa.com

Sample Number	Depth	Time	Sample Type	Container Type	VOC 8260	PCE & Daughter Prod.	NWTPH-Gx	BTEX (8260) / (8021)	NWTPH-HCID	NWTPH-Dx / Dx	PCB 8082	MTCA 5 Metals	RCRA 8 Metals	c PAH 8270	PAH 8270	Semi Vol 8270	Lead 6010, 6020	or 6200 per Ecology	Field Notes	
1	15s																		X	
2	16s																		X	
3	16d																		X	
4	17s																		X	
5	18s																		X	Unable to perform analysis Sample container broke at subcontracted lab.
6	19s																	X		
7	20s																	X		
8	20d																		X	
9	21s																		X	
10	22s																		X	
11	23s																		X	
12																				
13																				
14																				
15																				
16																				
17																				

Relinquished by: <u>[Signature]</u>	Date / Time: <u>2/21/23</u>	Received by: <u>[Signature]</u>	Date / Time: <u>2.21.23 12:18</u>	Sample Receipt Good Condition? <u>Y</u> <u>N</u> Cooler Temp. <u> </u> °C Sample Temp. <u> </u> °C Total Number of Containers <u> </u>	Remarks:
Relinquished by:	Date / Time:	Received by:	Date / Time:		
Relinquished by:	Date / Time:	Received by:	Date / Time:		

TAT: 24HR 48HR 6-DAY

Libby Environmental, Inc.

3322 South Bay Road NE

Olympia, WA 98506

Phone: (360) 352-2110

FAX: (360) 352-4154

Email: libbyenv@gmail.com

NSP - GRAVEL PIT PROJECT

ADESA

Libby Project # L23B086

Date Received 2/21/2023

Time Received 12:18 PM

Received By RJK

Sample Receipt Checklist

Chain of Custody

1. Is the Chain of Custody is complete? Yes No
2. How was the sample delivered? Hand Delivered Picked Up Shipped

Log In

3. Cooler or Shipping Container is present. Yes No N/A
4. Cooler or Shipping Container is in good condition. Yes No N/A
5. Cooler or Shipping Container has Custody Seals present. Yes No N/A
6. Was an attempt made to cool the samples? Yes No N/A
7. Temperature of cooler (0°C to 8°C recommended) 8.2 °C
8. Temperature of sample(s) (0°C to 8°C recommended) 10.1 °C
9. Did all containers arrive in good condition (unbroken)? Yes No
10. Is it clear what analyses were requested? Yes No
11. Did container labels match Chain of Custody? Yes No
12. Are matrices correctly identified on Chain of Custody? Yes No
13. Are correct containers used for the analysis indicated? Yes No
14. Is there sufficient sample volume for indicated analysis? Yes No
15. Were all containers properly preserved per each analysis? Yes No
16. Were VOA vials collected correctly (no headspace)? Yes No N/A
17. Were all holding times able to be met? Yes No

Discrepancies/ Notes

18. Was client notified of all discrepancies? Yes No N/A

Person Notified: _____

Date: _____

By Whom: _____

Via: _____

Regarding: _____

19. Comments. _____



Libby Environmental
Sherry Chilcutt
3322 South Bay Road NE
Olympia, WA 98506

RE: NSP - Gravel Pit
Work Order Number: 2302398

March 03, 2023

Attention Sherry Chilcutt:

Fremont Analytical, Inc. received 28 sample(s) on 2/22/2023 for the analyses presented in the following report.

Sample Moisture (Percent Moisture)
Total Metals by EPA Method 6020B

This report consists of the following:

- Case Narrative
- Analytical Results
- Applicable Quality Control Summary Reports
- Chain of Custody

All analyses were performed consistent with the Quality Assurance program of Fremont Analytical, Inc. Please contact the laboratory if you should have any questions about the results.

Thank you for using Fremont Analytical.

Sincerely,

Brianna Barnes
Project Manager



CLIENT: Libby Environmental
Project: NSP - Gravel Pit
Work Order: 2302398

Work Order Sample Summary

Lab Sample ID	Client Sample ID	Date/Time Collected	Date/Time Received
2302398-001	1s	02/21/2023 12:00 AM	02/22/2023 10:30 AM
2302398-002	2s	02/21/2023 12:00 AM	02/22/2023 10:30 AM
2302398-003	3s	02/21/2023 12:00 AM	02/22/2023 10:30 AM
2302398-004	4s	02/21/2023 12:00 AM	02/22/2023 10:30 AM
2302398-005	4d	02/21/2023 12:00 AM	02/22/2023 10:30 AM
2302398-006	5s	02/21/2023 12:00 AM	02/22/2023 10:30 AM
2302398-007	6s	02/21/2023 12:00 AM	02/22/2023 10:30 AM
2302398-008	7s	02/21/2023 12:00 AM	02/22/2023 10:30 AM
2302398-009	8s	02/21/2023 12:00 AM	02/22/2023 10:30 AM
2302398-010	8d	02/21/2023 12:00 AM	02/22/2023 10:30 AM
2302398-011	9s	02/21/2023 12:00 AM	02/22/2023 10:30 AM
2302398-012	10s	02/21/2023 12:00 AM	02/22/2023 10:30 AM
2302398-013	11s	02/21/2023 12:00 AM	02/22/2023 10:30 AM
2302398-014	12s	02/21/2023 12:00 AM	02/22/2023 10:30 AM
2302398-015	12d	02/21/2023 12:00 AM	02/22/2023 10:30 AM
2302398-016	13s	02/21/2023 12:00 AM	02/22/2023 10:30 AM
2302398-017	14s	02/21/2023 12:00 AM	02/22/2023 10:30 AM
2302398-018	15s	02/21/2023 12:00 AM	02/22/2023 10:30 AM
2302398-019	16s	02/21/2023 12:00 AM	02/22/2023 10:30 AM
2302398-020	16d	02/21/2023 12:00 AM	02/22/2023 10:30 AM
2302398-021	17s	02/21/2023 12:00 AM	02/22/2023 10:30 AM
2302398-022	18s	02/21/2023 12:00 AM	02/22/2023 10:30 AM
2302398-023	19s	02/21/2023 12:00 AM	02/22/2023 10:30 AM
2302398-024	20s	02/21/2023 12:00 AM	02/22/2023 10:30 AM
2302398-025	20d	02/21/2023 12:00 AM	02/22/2023 10:30 AM
2302398-026	21s	02/21/2023 12:00 AM	02/22/2023 10:30 AM
2302398-027	22s	02/21/2023 12:00 AM	02/22/2023 10:30 AM
2302398-028	23s	02/21/2023 12:00 AM	02/22/2023 10:30 AM

Note: If no "Time Collected" is supplied, a default of 12:00AM is assigned

CLIENT: Libby Environmental

Project: NSP - Gravel Pit

I. SAMPLE RECEIPT:

Samples receipt information is recorded on the attached Sample Receipt Checklist.

II. GENERAL REPORTING COMMENTS:

Results are reported on a wet weight basis unless dry-weight correction is denoted in the units field on the analytical report ("mg/kg-dry" or "ug/kg-dry").

Matrix Spike (MS) and MS Duplicate (MSD) samples are tested from an analytical batch of "like" matrix to check for possible matrix effect. The MS and MSD will provide site specific matrix data only for those samples which are spiked by the laboratory. The sample chosen for spike purposes may or may not have been a sample submitted in this sample delivery group. The validity of the analytical procedures for which data is reported in this analytical report is determined by the Laboratory Control Sample (LCS) and the Method Blank (MB). The LCS and the MB are processed with the samples and the MS/MSD to ensure method criteria are achieved throughout the entire analytical process.

III. ANALYSES AND EXCEPTIONS:

Exceptions associated with this report will be footnoted in the analytical results page(s) or the quality control summary page(s) and/or noted below.

Qualifiers:

- * - Flagged value is not within established control limits
- B - Analyte detected in the associated Method Blank
- D - Dilution was required
- E - Value above quantitation range
- H - Holding times for preparation or analysis exceeded
- I - Analyte with an internal standard that does not meet established acceptance criteria
- J - Analyte detected below Reporting Limit
- N - Tentatively Identified Compound (TIC)
- Q - Analyte with an initial or continuing calibration that does not meet established acceptance criteria
- S - Spike recovery outside accepted recovery limits
- ND - Not detected at the Reporting Limit
- R - High relative percent difference observed

Acronyms:

- %Rec - Percent Recovery
- CCB - Continued Calibration Blank
- CCV - Continued Calibration Verification
- DF - Dilution Factor
- DUP - Sample Duplicate
- HEM - Hexane Extractable Material
- ICV - Initial Calibration Verification
- LCS/LCSD - Laboratory Control Sample / Laboratory Control Sample Duplicate
- MCL - Maximum Contaminant Level
- MB or MBLANK - Method Blank
- MDL - Method Detection Limit
- MS/MSD - Matrix Spike / Matrix Spike Duplicate
- PDS - Post Digestion Spike
- Ref Val - Reference Value
- REP - Sample Replicate
- RL - Reporting Limit
- RPD - Relative Percent Difference
- SD - Serial Dilution
- SGT - Silica Gel Treatment
- SPK - Spike
- Surr - Surrogate



CLIENT: Libby Environmental

Project: NSP - Gravel Pit

Lab ID: 2302398-001

Collection Date: 2/21/2023

Client Sample ID: 1s

Matrix: Soil

Analyses	Result	RL	Qual	Units	DF	Date Analyzed
----------	--------	----	------	-------	----	---------------

Total Metals by EPA Method 6020B

Batch ID: 39546 Analyst: JR

Lead	34.5	0.932		mg/Kg-dry	1	2/27/2023 5:21:00 PM
------	------	-------	--	-----------	---	----------------------

Sample Moisture (Percent Moisture)

Batch ID: R82018 Analyst: ET

Percent Moisture	16.1	0.500		wt%	1	2/22/2023 12:15:03 PM
------------------	------	-------	--	-----	---	-----------------------

Lab ID: 2302398-002

Collection Date: 2/21/2023

Client Sample ID: 2s

Matrix: Soil

Analyses	Result	RL	Qual	Units	DF	Date Analyzed
----------	--------	----	------	-------	----	---------------

Total Metals by EPA Method 6020B

Batch ID: 39546 Analyst: JR

Lead	17.4	1.05		mg/Kg-dry	1	2/27/2023 5:28:00 PM
------	------	------	--	-----------	---	----------------------

Sample Moisture (Percent Moisture)

Batch ID: R82018 Analyst: ET

Percent Moisture	23.8	0.500		wt%	1	2/22/2023 12:15:03 PM
------------------	------	-------	--	-----	---	-----------------------

Lab ID: 2302398-003

Collection Date: 2/21/2023

Client Sample ID: 3s

Matrix: Soil

Analyses	Result	RL	Qual	Units	DF	Date Analyzed
----------	--------	----	------	-------	----	---------------

Total Metals by EPA Method 6020B

Batch ID: 39546 Analyst: JR

Lead	6.81	0.952		mg/Kg-dry	1	2/27/2023 5:30:00 PM
------	------	-------	--	-----------	---	----------------------

Sample Moisture (Percent Moisture)

Batch ID: R82018 Analyst: ET

Percent Moisture	17.9	0.500		wt%	1	2/22/2023 12:15:03 PM
------------------	------	-------	--	-----	---	-----------------------



CLIENT: Libby Environmental

Project: NSP - Gravel Pit

Lab ID: 2302398-004

Collection Date: 2/21/2023

Client Sample ID: 4s

Matrix: Soil

Analyses	Result	RL	Qual	Units	DF	Date Analyzed
----------	--------	----	------	-------	----	---------------

Total Metals by EPA Method 6020B

Batch ID: 39546 Analyst: JR

Lead	10.9	1.01		mg/Kg-dry	1	2/27/2023 5:32:00 PM
------	------	------	--	-----------	---	----------------------

Sample Moisture (Percent Moisture)

Batch ID: R82018 Analyst: ET

Percent Moisture	22.9	0.500		wt%	1	2/22/2023 12:15:03 PM
------------------	------	-------	--	-----	---	-----------------------

Lab ID: 2302398-005

Collection Date: 2/21/2023

Client Sample ID: 4d

Matrix: Soil

Analyses	Result	RL	Qual	Units	DF	Date Analyzed
----------	--------	----	------	-------	----	---------------

Total Metals by EPA Method 6020B

Batch ID: 39546 Analyst: JR

Lead	8.13	0.962		mg/Kg-dry	1	2/27/2023 5:35:00 PM
------	------	-------	--	-----------	---	----------------------

Sample Moisture (Percent Moisture)

Batch ID: R82018 Analyst: ET

Percent Moisture	18.8	0.500		wt%	1	2/22/2023 12:15:03 PM
------------------	------	-------	--	-----	---	-----------------------

Lab ID: 2302398-006

Collection Date: 2/21/2023

Client Sample ID: 5s

Matrix: Soil

Analyses	Result	RL	Qual	Units	DF	Date Analyzed
----------	--------	----	------	-------	----	---------------

Total Metals by EPA Method 6020B

Batch ID: 39546 Analyst: JR

Lead	6.25	0.927		mg/Kg-dry	1	2/27/2023 5:37:00 PM
------	------	-------	--	-----------	---	----------------------

Sample Moisture (Percent Moisture)

Batch ID: R82018 Analyst: ET

Percent Moisture	14.4	0.500		wt%	1	2/22/2023 12:15:03 PM
------------------	------	-------	--	-----	---	-----------------------



CLIENT: Libby Environmental

Project: NSP - Gravel Pit

Lab ID: 2302398-007

Collection Date: 2/21/2023

Client Sample ID: 6s

Matrix: Soil

Analyses	Result	RL	Qual	Units	DF	Date Analyzed
----------	--------	----	------	-------	----	---------------

Total Metals by EPA Method 6020B

Batch ID: 39546 Analyst: JR

Lead	47.4	0.942		mg/Kg-dry	1	2/27/2023 5:39:00 PM
------	------	-------	--	-----------	---	----------------------

Sample Moisture (Percent Moisture)

Batch ID: R82018 Analyst: ET

Percent Moisture	17.1	0.500		wt%	1	2/22/2023 12:15:03 PM
------------------	------	-------	--	-----	---	-----------------------

Lab ID: 2302398-008

Collection Date: 2/21/2023

Client Sample ID: 7s

Matrix: Soil

Analyses	Result	RL	Qual	Units	DF	Date Analyzed
----------	--------	----	------	-------	----	---------------

Total Metals by EPA Method 6020B

Batch ID: 39546 Analyst: JR

Lead	49.2	0.868		mg/Kg-dry	1	2/27/2023 5:42:00 PM
------	------	-------	--	-----------	---	----------------------

Sample Moisture (Percent Moisture)

Batch ID: R82018 Analyst: ET

Percent Moisture	10.7	0.500		wt%	1	2/22/2023 12:15:03 PM
------------------	------	-------	--	-----	---	-----------------------

Lab ID: 2302398-009

Collection Date: 2/21/2023

Client Sample ID: 8s

Matrix: Soil

Analyses	Result	RL	Qual	Units	DF	Date Analyzed
----------	--------	----	------	-------	----	---------------

Total Metals by EPA Method 6020B

Batch ID: 39546 Analyst: JR

Lead	266	2.66	D	mg/Kg-dry	10	3/3/2023 2:34:00 PM
------	-----	------	---	-----------	----	---------------------

Sample Moisture (Percent Moisture)

Batch ID: R82018 Analyst: ET

Percent Moisture	9.94	0.500		wt%	1	2/22/2023 12:15:03 PM
------------------	------	-------	--	-----	---	-----------------------



CLIENT: Libby Environmental

Project: NSP - Gravel Pit

Lab ID: 2302398-010

Collection Date: 2/21/2023

Client Sample ID: 8d

Matrix: Soil

Analyses	Result	RL	Qual	Units	DF	Date Analyzed
----------	--------	----	------	-------	----	---------------

Total Metals by EPA Method 6020B

Batch ID: 39546 Analyst: JR

Lead	258	8.76	D	mg/Kg-dry	10	3/3/2023 2:37:00 PM
------	-----	------	---	-----------	----	---------------------

Sample Moisture (Percent Moisture)

Batch ID: R82018 Analyst: ET

Percent Moisture	8.64	0.500		wt%	1	2/22/2023 12:15:03 PM
------------------	------	-------	--	-----	---	-----------------------

Lab ID: 2302398-012

Collection Date: 2/21/2023

Client Sample ID: 10s

Matrix: Soil

Analyses	Result	RL	Qual	Units	DF	Date Analyzed
----------	--------	----	------	-------	----	---------------

Total Metals by EPA Method 6020B

Batch ID: 39565 Analyst: JR

Lead	17.4	0.922		mg/Kg-dry	1	2/28/2023 12:24:00 PM
------	------	-------	--	-----------	---	-----------------------

Sample Moisture (Percent Moisture)

Batch ID: R82018 Analyst: ET

Percent Moisture	13.9	0.500		wt%	1	2/22/2023 12:15:03 PM
------------------	------	-------	--	-----	---	-----------------------

Lab ID: 2302398-013

Collection Date: 2/21/2023

Client Sample ID: 11s

Matrix: Soil

Analyses	Result	RL	Qual	Units	DF	Date Analyzed
----------	--------	----	------	-------	----	---------------

Total Metals by EPA Method 6020B

Batch ID: 39565 Analyst: JR

Lead	16.5	0.845		mg/Kg-dry	1	2/28/2023 12:39:00 PM
------	------	-------	--	-----------	---	-----------------------

Sample Moisture (Percent Moisture)

Batch ID: R82018 Analyst: ET

Percent Moisture	10.4	0.500		wt%	1	2/22/2023 12:15:03 PM
------------------	------	-------	--	-----	---	-----------------------



CLIENT: Libby Environmental

Project: NSP - Gravel Pit

Lab ID: 2302398-014

Collection Date: 2/21/2023

Client Sample ID: 12s

Matrix: Soil

Analyses	Result	RL	Qual	Units	DF	Date Analyzed
<u>Total Metals by EPA Method 6020B</u>				Batch ID: 39565		Analyst: JR
Lead	36.0	0.840		mg/Kg-dry	1	2/28/2023 12:41:00 PM
<u>Sample Moisture (Percent Moisture)</u>				Batch ID: R82018		Analyst: ET
Percent Moisture	7.68	0.500		wt%	1	2/22/2023 12:15:03 PM

Lab ID: 2302398-015

Collection Date: 2/21/2023

Client Sample ID: 12d

Matrix: Soil

Analyses	Result	RL	Qual	Units	DF	Date Analyzed
<u>Total Metals by EPA Method 6020B</u>				Batch ID: 39565		Analyst: JR
Lead	45.4	0.797		mg/Kg-dry	1	2/28/2023 12:43:00 PM
<u>Sample Moisture (Percent Moisture)</u>				Batch ID: R82018		Analyst: ET
Percent Moisture	7.69	0.500		wt%	1	2/22/2023 12:15:03 PM

Lab ID: 2302398-016

Collection Date: 2/21/2023

Client Sample ID: 13s

Matrix: Soil

Analyses	Result	RL	Qual	Units	DF	Date Analyzed
<u>Total Metals by EPA Method 6020B</u>				Batch ID: 39565		Analyst: JR
Lead	190	8.73	D	mg/Kg-dry	10	3/1/2023 11:23:00 AM
<u>Sample Moisture (Percent Moisture)</u>				Batch ID: R82018		Analyst: ET
Percent Moisture	9.85	0.500		wt%	1	2/22/2023 12:15:03 PM



CLIENT: Libby Environmental

Project: NSP - Gravel Pit

Lab ID: 2302398-017

Collection Date: 2/21/2023

Client Sample ID: 14s

Matrix: Soil

Analyses	Result	RL	Qual	Units	DF	Date Analyzed
----------	--------	----	------	-------	----	---------------

Total Metals by EPA Method 6020B

Batch ID: 39565 Analyst: JR

Lead	173	9.30	D	mg/Kg-dry	10	3/1/2023 11:26:00 AM
------	-----	------	---	-----------	----	----------------------

Sample Moisture (Percent Moisture)

Batch ID: R82018 Analyst: ET

Percent Moisture	14.0	0.500		wt%	1	2/22/2023 12:15:03 PM
------------------	------	-------	--	-----	---	-----------------------

Lab ID: 2302398-018

Collection Date: 2/21/2023

Client Sample ID: 15s

Matrix: Soil

Analyses	Result	RL	Qual	Units	DF	Date Analyzed
----------	--------	----	------	-------	----	---------------

Total Metals by EPA Method 6020B

Batch ID: 39565 Analyst: JR

Lead	192	8.30	D	mg/Kg-dry	10	3/1/2023 11:28:00 AM
------	-----	------	---	-----------	----	----------------------

Sample Moisture (Percent Moisture)

Batch ID: R82022 Analyst: ET

Percent Moisture	10.8	0.500		wt%	1	2/22/2023 1:09:56 PM
------------------	------	-------	--	-----	---	----------------------

Lab ID: 2302398-019

Collection Date: 2/21/2023

Client Sample ID: 16s

Matrix: Soil

Analyses	Result	RL	Qual	Units	DF	Date Analyzed
----------	--------	----	------	-------	----	---------------

Total Metals by EPA Method 6020B

Batch ID: 39565 Analyst: JR

Lead	185	9.25	D	mg/Kg-dry	10	3/1/2023 11:30:00 AM
------	-----	------	---	-----------	----	----------------------

Sample Moisture (Percent Moisture)

Batch ID: R82022 Analyst: ET

Percent Moisture	14.9	0.500		wt%	1	2/22/2023 1:09:56 PM
------------------	------	-------	--	-----	---	----------------------



CLIENT: Libby Environmental

Project: NSP - Gravel Pit

Lab ID: 2302398-020

Collection Date: 2/21/2023

Client Sample ID: 16d

Matrix: Soil

Analyses	Result	RL	Qual	Units	DF	Date Analyzed
<u>Total Metals by EPA Method 6020B</u>				Batch ID: 39565		Analyst: JR
Lead	61.0	0.863		mg/Kg-dry	1	2/28/2023 12:58:00 PM
<u>Sample Moisture (Percent Moisture)</u>				Batch ID: R82022		Analyst: ET
Percent Moisture	8.75	0.500		wt%	1	2/22/2023 1:09:56 PM

Lab ID: 2302398-021

Collection Date: 2/21/2023

Client Sample ID: 17s

Matrix: Soil

Analyses	Result	RL	Qual	Units	DF	Date Analyzed
<u>Total Metals by EPA Method 6020B</u>				Batch ID: 39565		Analyst: JR
Lead	81.8	1.03		mg/Kg-dry	1	2/28/2023 1:00:00 PM
<u>Sample Moisture (Percent Moisture)</u>				Batch ID: R82022		Analyst: ET
Percent Moisture	27.3	0.500		wt%	1	2/22/2023 1:09:56 PM

Lab ID: 2302398-023

Collection Date: 2/21/2023

Client Sample ID: 19s

Matrix: Soil

Analyses	Result	RL	Qual	Units	DF	Date Analyzed
<u>Total Metals by EPA Method 6020B</u>				Batch ID: 39565		Analyst: JR
Lead	18.2	0.880		mg/Kg-dry	1	2/28/2023 1:02:00 PM
<u>Sample Moisture (Percent Moisture)</u>				Batch ID: R82022		Analyst: ET
Percent Moisture	10.6	0.500		wt%	1	2/22/2023 1:09:56 PM



CLIENT: Libby Environmental

Project: NSP - Gravel Pit

Lab ID: 2302398-024

Collection Date: 2/21/2023

Client Sample ID: 20s

Matrix: Soil

Analyses	Result	RL	Qual	Units	DF	Date Analyzed
----------	--------	----	------	-------	----	---------------

Total Metals by EPA Method 6020B

Batch ID: 39565 Analyst: JR

Lead	591	8.58	D	mg/Kg-dry	10	3/1/2023 11:33:00 AM
------	-----	------	---	-----------	----	----------------------

Sample Moisture (Percent Moisture)

Batch ID: R82022 Analyst: ET

Percent Moisture	11.7	0.500		wt%	1	2/22/2023 1:09:56 PM
------------------	------	-------	--	-----	---	----------------------

Lab ID: 2302398-025

Collection Date: 2/21/2023

Client Sample ID: 20d

Matrix: Soil

Analyses	Result	RL	Qual	Units	DF	Date Analyzed
----------	--------	----	------	-------	----	---------------

Total Metals by EPA Method 6020B

Batch ID: 39565 Analyst: JR

Lead	203	8.81	D	mg/Kg-dry	10	3/1/2023 11:35:00 AM
------	-----	------	---	-----------	----	----------------------

Sample Moisture (Percent Moisture)

Batch ID: R82022 Analyst: ET

Percent Moisture	12.0	0.500		wt%	1	2/22/2023 1:09:56 PM
------------------	------	-------	--	-----	---	----------------------

Lab ID: 2302398-026

Collection Date: 2/21/2023

Client Sample ID: 21s

Matrix: Soil

Analyses	Result	RL	Qual	Units	DF	Date Analyzed
----------	--------	----	------	-------	----	---------------

Total Metals by EPA Method 6020B

Batch ID: 39565 Analyst: JR

Lead	25.5	1.16		mg/Kg-dry	1	2/28/2023 1:09:00 PM
------	------	------	--	-----------	---	----------------------

Sample Moisture (Percent Moisture)

Batch ID: R82022 Analyst: ET

Percent Moisture	32.3	0.500		wt%	1	2/22/2023 1:09:56 PM
------------------	------	-------	--	-----	---	----------------------



CLIENT: Libby Environmental

Project: NSP - Gravel Pit

Lab ID: 2302398-027

Collection Date: 2/21/2023

Client Sample ID: 22s

Matrix: Soil

Analyses	Result	RL	Qual	Units	DF	Date Analyzed
----------	--------	----	------	-------	----	---------------

Total Metals by EPA Method 6020B

Batch ID: 39565 Analyst: JR

Lead	26.5	0.920		mg/Kg-dry	1	2/28/2023 1:11:00 PM
------	------	-------	--	-----------	---	----------------------

Sample Moisture (Percent Moisture)

Batch ID: R82022 Analyst: ET

Percent Moisture	16.4	0.500		wt%	1	2/22/2023 1:09:56 PM
------------------	------	-------	--	-----	---	----------------------

Lab ID: 2302398-028

Collection Date: 2/21/2023

Client Sample ID: 23s

Matrix: Soil

Analyses	Result	RL	Qual	Units	DF	Date Analyzed
----------	--------	----	------	-------	----	---------------

Total Metals by EPA Method 6020B

Batch ID: 39565 Analyst: JR

Lead	235	8.40	D	mg/Kg-dry	10	3/1/2023 11:37:00 AM
------	-----	------	---	-----------	----	----------------------

Sample Moisture (Percent Moisture)

Batch ID: R82022 Analyst: ET

Percent Moisture	11.8	0.500		wt%	1	2/22/2023 1:09:56 PM
------------------	------	-------	--	-----	---	----------------------

Work Order: 2302398
 CLIENT: Libby Environmental
 Project: NSP - Gravel Pit

QC SUMMARY REPORT
Total Metals by EPA Method 6020B

Sample ID: MB-39546	SampType: MBLK	Units: mg/Kg			Prep Date: 2/27/2023	RunNo: 82118					
Client ID: MBLKS	Batch ID: 39546				Analysis Date: 2/27/2023	SeqNo: 1704828					
Analyte	Result	RL	SPK value	SPK Ref Val	%REC	LowLimit	HighLimit	RPD Ref Val	%RPD	RPDLimit	Qual

Lead ND 1.00

Sample ID: LCS-39546	SampType: LCS	Units: mg/Kg			Prep Date: 2/27/2023	RunNo: 82118					
Client ID: LCSS	Batch ID: 39546				Analysis Date: 2/27/2023	SeqNo: 1704829					
Analyte	Result	RL	SPK value	SPK Ref Val	%REC	LowLimit	HighLimit	RPD Ref Val	%RPD	RPDLimit	Qual

Lead 19.0 0.800 20.00 0 95.0 80 120

Sample ID: 2302441-001AMS	SampType: MS	Units: mg/Kg-dry			Prep Date: 2/27/2023	RunNo: 82118					
Client ID: BATCH	Batch ID: 39546				Analysis Date: 2/27/2023	SeqNo: 1704832					
Analyte	Result	RL	SPK value	SPK Ref Val	%REC	LowLimit	HighLimit	RPD Ref Val	%RPD	RPDLimit	Qual

Lead 94.3 3.65 91.14 9.634 92.9 75 125

Sample ID: 2302441-001AMSD	SampType: MSD	Units: mg/Kg-dry			Prep Date: 2/27/2023	RunNo: 82118					
Client ID: BATCH	Batch ID: 39546				Analysis Date: 2/27/2023	SeqNo: 1704833					
Analyte	Result	RL	SPK value	SPK Ref Val	%REC	LowLimit	HighLimit	RPD Ref Val	%RPD	RPDLimit	Qual

Lead 93.5 3.59 89.78 9.634 93.4 75 125 94.28 0.791 20

Sample ID: MB-39565	SampType: MBLK	Units: mg/Kg			Prep Date: 2/28/2023	RunNo: 82137					
Client ID: MBLKS	Batch ID: 39565				Analysis Date: 2/28/2023	SeqNo: 1705419					
Analyte	Result	RL	SPK value	SPK Ref Val	%REC	LowLimit	HighLimit	RPD Ref Val	%RPD	RPDLimit	Qual

Lead ND 1.00

Work Order: 2302398
CLIENT: Libby Environmental
Project: NSP - Gravel Pit

QC SUMMARY REPORT
Total Metals by EPA Method 6020B

Sample ID: LCS-39565		SampType: LCS		Units: mg/Kg		Prep Date: 2/28/2023		RunNo: 82137			
Client ID: LCSS		Batch ID: 39565				Analysis Date: 2/28/2023		SeqNo: 1705420			
Analyte	Result	RL	SPK value	SPK Ref Val	%REC	LowLimit	HighLimit	RPD Ref Val	%RPD	RPDLimit	Qual
Lead	21.1	0.781	19.53	0	108	80	120				

Sample ID: 2302398-012AMS		SampType: MS		Units: mg/Kg-dry		Prep Date: 2/28/2023		RunNo: 82137			
Client ID: 10s		Batch ID: 39565				Analysis Date: 2/28/2023		SeqNo: 1705425			
Analyte	Result	RL	SPK value	SPK Ref Val	%REC	LowLimit	HighLimit	RPD Ref Val	%RPD	RPDLimit	Qual
Lead	36.6	0.867	21.67	17.40	88.6	75	125				

Sample ID: 2302398-012AMSD		SampType: MSD		Units: mg/Kg-dry		Prep Date: 2/28/2023		RunNo: 82137			
Client ID: 10s		Batch ID: 39565				Analysis Date: 2/28/2023		SeqNo: 1705426			
Analyte	Result	RL	SPK value	SPK Ref Val	%REC	LowLimit	HighLimit	RPD Ref Val	%RPD	RPDLimit	Qual
Lead	40.1	0.914	22.86	17.40	99.5	75	125	36.59	9.25	20	

Client Name: **LIBBY**
 Logged by: **Clare Griggs**

Work Order Number: **2302398**
 Date Received: **2/22/2023 10:30:00 AM**

Chain of Custody

1. Is Chain of Custody complete? Yes No Not Present
 2. How was the sample delivered? UPS

Log In

3. Coolers are present? Yes No NA
 4. Shipping container/cooler in good condition? Yes No
 5. Custody Seals present on shipping container/cooler?
 (Refer to comments for Custody Seals not intact) Yes No Not Present
 6. Was an attempt made to cool the samples? Yes No NA
 7. Were all items received at a temperature of >2°C to 6°C * Yes No NA
 8. Sample(s) in proper container(s)? Yes No
 9. Sufficient sample volume for indicated test(s)? Yes No
 10. Are samples properly preserved? Yes No
 11. Was preservative added to bottles? Yes No NA
 12. Is there headspace in the VOA vials? Yes No NA
 13. Did all samples containers arrive in good condition(unbroken)? Yes No
 14. Does paperwork match bottle labels? Yes No
 15. Are matrices correctly identified on Chain of Custody? Yes No
 16. Is it clear what analyses were requested? Yes No
 17. Were all holding times able to be met? Yes No

Special Handling (if applicable)

18. Was client notified of all discrepancies with this order? Yes No NA

Person Notified:	<input type="text" value="Emily Bushlen"/>	Date:	<input type="text" value="2/23/2023"/>
By Whom:	<input type="text" value="Brianna Barnes"/>	Via:	<input checked="" type="checkbox"/> eMail <input type="checkbox"/> Phone <input type="checkbox"/> Fax <input type="checkbox"/> In Person
Regarding:	<input type="text" value="Volume was spilled for 9s and 18s before analysis was started."/>		
Client Instructions:	<input type="text" value="Proceed with other samples."/>		

19. Additional remarks:

Item Information

Item #	Temp °C
Sample	2.1

* Note: DoD/ELAP and TNI require items to be received at 4°C +/- 2°C



Libby Environmental, Inc.

3322 South Bay Road NE • Olympia, WA 98506-2957

**SUBCONTRACT
ORDER
L23B086**

Sending Laboratory:

Libby Environmental, Inc.
3322 South Bay Road NE
Olympia, WA 98506
Phone: 360-352-2110
Fax: 360-352-4154

Project Manager: Sherry Chilcutt
LibbyEnv@gmail.com

Subcontracted Laboratory:

2302398

Fremont Analytical, Inc.
3600 Fremont Ave N
Seattle, WA 98103
Phone: (206) 352-3790
Fax:

Requested Turnaround (TAT) STD

Project: NSP - Gravel Pit

Analysis	Comments
Client Sample ID: 1s Soil Sampled: 02/21/2023 00:00 Metals SUB Pb Containers Supplied:	6000 Series Lab ID: L23B086-01
Client Sample ID: 2s Soil Sampled: 02/21/2023 00:00 Metals SUB Pb Containers Supplied:	6000 Series Lab ID: L23B086-02
Client Sample ID: 3s Soil Sampled: 02/21/2023 00:00 Metals SUB Pb Containers Supplied:	6000 Series Lab ID: L23B086-03
Client Sample ID: 4s Soil Sampled: 02/21/2023 00:00 Metals SUB Pb Containers Supplied:	6000 Series Lab ID: L23B086-04
Client Sample ID: 4d Soil Sampled: 02/21/2023 00:00 Metals SUB Pb Containers Supplied:	6000 Series Lab ID: L23B086-05
Client Sample ID: 5s Soil Sampled: 02/21/2023 00:00 Metals SUB Pb Containers Supplied:	6000 Series Lab ID: L23B086-06

Released By [Signature] Date 2.21.23
[Signature] 2.21.23

Received By [Signature] Date 2/22/23 10:30



Libby Environmental, Inc.

3322 South Bay Road NE • Olympia, WA 98506-2957

**SUBCONTRACT
ORDER
L23B086
(Continued)**

2302398

Project: NSP - Gravel Pit

Analysis	Comments
Client Sample ID: 6s Soil Sampled: 02/21/2023 00:00 Metals SUB Pb Containers Supplied:	6000 Series Lab ID: L23B086-07
Client Sample ID: 7s Soil Sampled: 02/21/2023 00:00 Metals SUB Pb Containers Supplied:	6000 Series Lab ID: L23B086-08
Client Sample ID: 8s Soil Sampled: 02/21/2023 00:00 Metals SUB Pb Containers Supplied:	6000 Series Lab ID: L23B086-09
Client Sample ID: 8d Soil Sampled: 02/21/2023 00:00 Metals SUB Pb Containers Supplied:	6000 Series Lab ID: L23B086-10
Client Sample ID: 9s Soil Sampled: 02/21/2023 00:00 Metals SUB Pb Containers Supplied:	6000 Series Lab ID: L23B086-11
Client Sample ID: 10s Soil Sampled: 02/21/2023 00:00 Metals SUB Pb Containers Supplied:	6000 Series Lab ID: L23B086-12
Client Sample ID: 11s Soil Sampled: 02/21/2023 00:00 Metals SUB Pb Containers Supplied:	6000 Series Lab ID: L23B086-13
Client Sample ID: 12s Soil Sampled: 02/21/2023 00:00 Metals SUB Pb Containers Supplied:	6000 Series Lab ID: L23B086-14

Released By

2.21.23
Date

Received By

2/22/23 10:30
Date



Libby Environmental, Inc.

3322 South Bay Road NE • Olympia, WA 98506-2957

**SUBCONTRACT
ORDER
L23B086
(Continued)**

2302398

Project: NSP - Gravel Pit

Analysis	Comments
Client Sample ID: 12d Soil Sampled: 02/21/2023 00:00 Metals SUB Pb Containers Supplied:	6000 Series Lab ID: L23B086-15
Client Sample ID: 13s Soil Sampled: 02/21/2023 00:00 Metals SUB Pb Containers Supplied:	6000 Series Lab ID: L23B086-16
Client Sample ID: 14s Soil Sampled: 02/21/2023 00:00 Metals SUB Pb Containers Supplied:	6000 Series Lab ID: L23B086-17
Client Sample ID: 15s Soil Sampled: 02/21/2023 00:00 Metals SUB Pb Containers Supplied:	6000 Series Lab ID: L23B086-18
Client Sample ID: 16s Soil Sampled: 02/21/2023 00:00 Metals SUB Pb Containers Supplied:	6000 Series Lab ID: L23B086-19
Client Sample ID: 16d Soil Sampled: 02/21/2023 00:00 Metals SUB Pb Containers Supplied:	6000 Series Lab ID: L23B086-20
Client Sample ID: 17s Soil Sampled: 02/21/2023 00:00 Metals SUB Pb Containers Supplied:	6000 Series Lab ID: L23B086-21
Client Sample ID: 18s Soil Sampled: 02/21/2023 00:00 Metals SUB Pb Containers Supplied:	6000 Series Lab ID: L23B086-22

Released By

Date 2-21-23

Received By

Date 2/22/23 10:30



Libby Environmental, Inc.

3322 South Bay Road NE • Olympia, WA 98506-2957

**SUBCONTRACT
ORDER
L23B086
(Continued)**

Project: NSP - Gravel Pit

2302398

Analysis	Comments
Client Sample ID: 19s Soil Sampled: 02/21/2023 00:00 Metals SUB Pb Containers Supplied:	6000 Series Lab ID: L23B086-23
Client Sample ID: 20s Soil Sampled: 02/21/2023 00:00 Metals SUB Pb Containers Supplied:	6000 Series Lab ID: L23B086-24
Client Sample ID: 20d Soil Sampled: 02/21/2023 00:00 Metals SUB Pb Containers Supplied:	6000 Series Lab ID: L23B086-25
Client Sample ID: 21s Soil Sampled: 02/21/2023 00:00 Metals SUB Pb Containers Supplied:	6000 Series Lab ID: L23B086-26
Client Sample ID: 22s Soil Sampled: 02/21/2023 00:00 Metals SUB Pb Containers Supplied:	6000 Series Lab ID: L23B086-27
Client Sample ID: 23s Soil Sampled: 02/21/2023 00:00 Metals SUB Pb Containers Supplied:	6000 Series Lab ID: L23B086-28

Released By

2-21-23

Date

Received By

2/22/23 10:30

Date

Page 20 of 20

**NISQUALLY STATE PARK
LEAD ASSESSMENT OF BORROW PIT**

Conducted On:

**NISQUALLY STATE PARK BORROW PIT
LATITUDE: 46.861251, LONGITUDE: -122.321474
MASHEL PRAIRIE ROAD
EATONVILLE, WASHINGTON 98328**

**November 14, 2023
PROJECT NUMBER: 0223-03**

Prepared for:

**RWD | LANDSCAPE ARCHITECTS
BOB DROLL, PLA, ASLA, PRESIDENT
4405 7TH AVENUE SE, SUITE 203
LACEY, WA 98503
O: 360.456.3813 | C: 360.481.6479
BOB@RWDROLL.COM**

AND

**WASHINGTON STATE PARKS
1111 ISRAEL ROAD SW
TUMWATER, WA 98501-6512**



Prepared by:

ADESA, LLC
197 Central Avenue E
Tenino, WA 98589



Assessment Summary

ADESA has completed a second round of soil sampling in association with the preliminary lead assessment of the gravel/borrow pit located at approximately latitude 46.861251°N and longitude -122.321474°W within Nisqually State Park, Mashel Prairie Road, Eatonville, Washington 98328. The borrow pit is an approximately 1.58-acre (68,758.85 SF) portion of Pierce County Assessor Parcel Number 0416201006 (Subject Property/borrow pit). This assessment is being performed for RWD Landscape Architects and Washington State Parks to aid in the determination of the suitability of the material in the borrow pit for use as fill material.



Figure 1.0: Property Location Map

Based on the limited review of aerial photographs, it appears that the borrow pit was first developed circa 1970, possibly in conjunction with the adjoining former town of Eatonville Landfill site (Ecology Facility Site ID No. 85933) to the south beyond a narrow power utility corridor. Aerial photographs of the area suggest that the former landfill was in operation by 1955 or earlier. The landfill site is currently undergoing a remedial investigation to determine the extent of any soil and groundwater impacts.

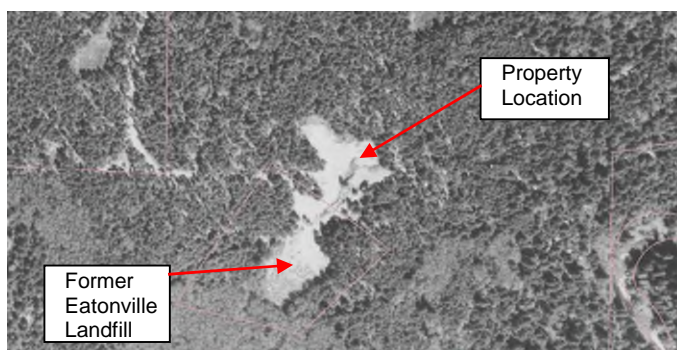

Gravel Pit and Adjacent Landfill Circa 1970



Prior sampling of the Subject Property occurred in 2021, when GSI Water Solutions, Inc., while performing a remedial investigation on the adjoining former landfill, collected and analyzed one 30-point composite sample of surficial soil from the borrow pit. The sample exhibited a concentration of lead at 6,000 mg/kg, well above the Washington State Department of Ecology MTCA Method A Cleanup Level in soil of 250 mg/kg. Based on the indications that the pit was historically used as a shooting range (spent shells/casings), it was suggested that this was the source of the lead. Elevated levels of lead have also been discovered in the surficial soil of the landfill. The GSI Water Solutions, Inc. results are provided in “Figure 9-2 Soil Analytical Results – ISM” (2021), which is attached in the Appendix.

February 20, 2023: On February 20, 2023, ADESA established a 53 ft (northeast/southwest) by 64.25 ft (northwest/southeast) sampling grid over the 1.58 acre area (Decision Unit 1/DU1), and collected a total of 28 soil samples from grid locations at a depth of 6 inches below the surface (“s” samples collected from every location) and 12 inches below the surface (“d” samples collected from every 4th location). Due to the similar historical and proposed uses of the Subject Property, the entire area is considered a single Decision Unit (DU). The soil samples were collected using clean, stainless steel hand tools and placed in labeled, laboratory supplied four-ounce glass jars with Teflon-lined lids. All of the soil samples were submitted, under chain of custody, to Libby Environmental Inc./Freemont Analytical for lead analysis by EPA Method 6020B. **Samples 9s and 18s were destroyed/broken by the laboratory and were subsequently resampled and analyzed during the current/October sampling event.**

October 12, 2023: On October 12, 2023, ADESA returned to the gravel pit, collecting samples from points within the Decision Unit at locations offset along the established grid lines, 26.5 ft northeast and southwest, and 32.125 ft northwest and southeast, from the previously identified sample locations exhibiting elevated lead concentrations in excess of 100 mg/kg. Additionally, sample locations 9s and 18s were re-sampled to replace the samples damaged during the February sampling event. A total of 20 soil samples were collected at a depth of 6 inches below the surface. The soil samples were collected using clean, stainless steel hand tools and placed in labeled, laboratory supplied four-ounce glass jars with Teflon-lined lids. All of the soil samples were submitted, under chain of custody, to Libby Environmental Inc./Friedman & Bruya for lead analysis by EPA Method 6020B. Samples 27s and 33s, the two samples found to contain the highest lead concentrations, were submitted to Fremont Analytical and further analyzed for leachable lead using Toxicity Characteristic Leaching Procedure (TCLP) by EPA Method 6020B with TCLP Extraction, EPA Method 1311.

At the time of the October sampling event State Parks was storing soil overburden delivered from a construction project at Millersylvania State Park in a pile located in the central area of the gravel pit. Consequently, proposed samples 32s and 43s were not sampled due to obstructions on the sampling date.

Results

The laboratory results of the sample analysis and sample location map are presented on the following pages, and the results of the assessment are summarized below:

- The highest lead concentration was exhibited in sample 27s at 7,990 mg/kg.
- Lead concentrations in excess of the Washington State Department of Ecology MTCA Method A Cleanup Level for Unrestricted Land Use (250 mg/kg) were detected in samples 8s, 8d, 20s, 27s, 28s, 29s, 30s, 31s, 33s, 34s, 36s and 37s.



- The lead concentrations identified in the remaining samples within the DU were below the cleanup level established by Ecology.
- TCLP lead analysis of sample 33s identified leachable lead with a result of 17.1 mg/L, exceeding the non-hazardous waste disposal criteria of 5 mg/L indicating that some amount of the lead impacted soil may require disposal as a toxic dangerous waste (Code D008; Toxicity Characteristic List from Chapter 173-303-090 WAC). TCLP lead analysis of sample 27s yielded a result of 3.01 mg/L, below the non-hazardous waste disposal criteria. These results could be a reflection of the varied lead sources from different ammunition historically used for recreational shooting on the site.

Discussion

The majority of the soil samples with concentrations in excess of the Method A Cleanup Level were collected from locations on the floor of the gravel pit, except for: samples 8s/8d and 37s, which were collected from the middle slope of a hill the west-central area of the pit that generally extends from sample 9s to sample 6s; sample 20s, which was collected at the toe of the slope along the south side of the gravel pit; and sample 27s, which was collected at the toe of the slope on the east-northeastern side of the gravel pit, on the edge of the area described as the “working face” of the gravel pit.

Based on the results to date, it may be feasible to utilize pit material collected from the working face in the area of samples 17s, 18s and 40s. Additionally, it may be possible to isolate the upper/outer 12 inches of material from the wall/floor of the gravel pit and stockpile the lead impacted soil for later remedial actions.

Recommendations

ADESA recommends that the site be enrolled in the Washington State Department of Ecology Voluntary Cleanup Program (VCP) to seek technical assistance regarding the use of any pit material for park projects and for the remediation of the lead impacted soil.



Nisqually State Park Borrow Pit
Lead Assessment October 2023

Sample ID	Latitude (Decimal Degrees)	Longitude (Decimal Degrees)	Depth (Inches)	Lead Concentration (mg/kg)
1s	46.861177°N	-122.322152°W	6	34.50
2s	46.861290°N	-122.322015°W	6	17.40
3s	46.861403°N	-122.321881°W	6	6.81
4s	46.861516°N	-122.321744°W	6	10.90
4d	46.861516°N	-122.321744°W	12	8.13
5s	46.861628°N	-122.321270°W	6	6.25
6s	46.861516°N	-122.321407°W	6	47.40
7s	46.861404°N	-122.321542°W	6	49.20
8s	46.861290°N	-122.321679°W	6	266.00
8d	46.861290°N	-122.321679°W	12	258.00
9s	46.861178°N	-122.321816°W	6	24.7
10s	46.861065°N	-122.321952°W	6	17.40
11s	46.860950°N	-122.321751°W	6	16.50
12s	46.861064°N	-122.321615°W	6	36.00
12d	46.861064°N	-122.321615°W	12	45.40
13s	46.861178°N	-122.321478°W	6	190.00
14s	46.861291°N	-122.321341°W	6	173.00
15s	46.861404°N	-122.321205°W	6	192.00
16s	46.861517°N	-122.321068°W	6	185.00
16d	46.861517°N	-122.321068°W	12	61.00
17s	46.861404°N	-122.320867°W	6	81.80
18s	46.861290°N	-122.321004°W	6	9.31
19s	46.861178°N	-122.321142°W	6	18.20
20s	46.861064°N	-122.321278°W	6	591.00
20d	46.861064°N	-122.321278°W	12	203.00
21s	46.8610951°N	-122.321414°W	6	25.50
22s	46.860952°N	-122.321078°W	6	26.50
23s	46.861065°N	-122.320941°W	6	235.00
24s	46.861565°N	-122.321163°W	6	70.8
25s	46.861585°N	-122.320981°W	6	136



Sample ID	Latitude (Decimal Degrees)	Longitude (Decimal Degrees)	Depth (Inches)	Lead Concentration (mg/kg)
26s	46.861462°N	-122.320973°W	6	151
27s	46.861458°N	-122.321134°W	6	7,990
28s	46.861457°N	-122.321306°W	6	848
29s	46.861347°N	-122.321110°W	6	509
30s	46.861348°N	-122.321263°W	6	318
31s	46.861343°N	-122.321434°W	6	336
32s	46.861233°N	-122.321241°W	Not Sampled	Not Sampled
33s	46.861235°N	-122.321405°W	6	2,230
34s	46.861125°N	-122.321539°W	6	467
35s	46.861227°N	-122.321576°W	6	110
36s	46.861119°N	-122.321381°W	6	267
37s	46.861235°N	-122.321740°W	6	549
38s	46.861007°N	-122.321338°W	6	164
39s	46.861005°N	-122.321174°W	6	20.3
40s	46.861119°N	-122.321043°W	6	12.9
41s	46.861341°N	-122.321783°W	6	41.7
42s	46.861343°N	-122.321603°W	6	158
43s	46.861117°N	-122.321204°W	Not Sampled	Not Sampled
Washington State Department of Ecology Method A Cleanup Level				250

Results depicted in red represent concentrations in excess of current state cleanup levels. The laboratory documentation is presented in the Appendix.

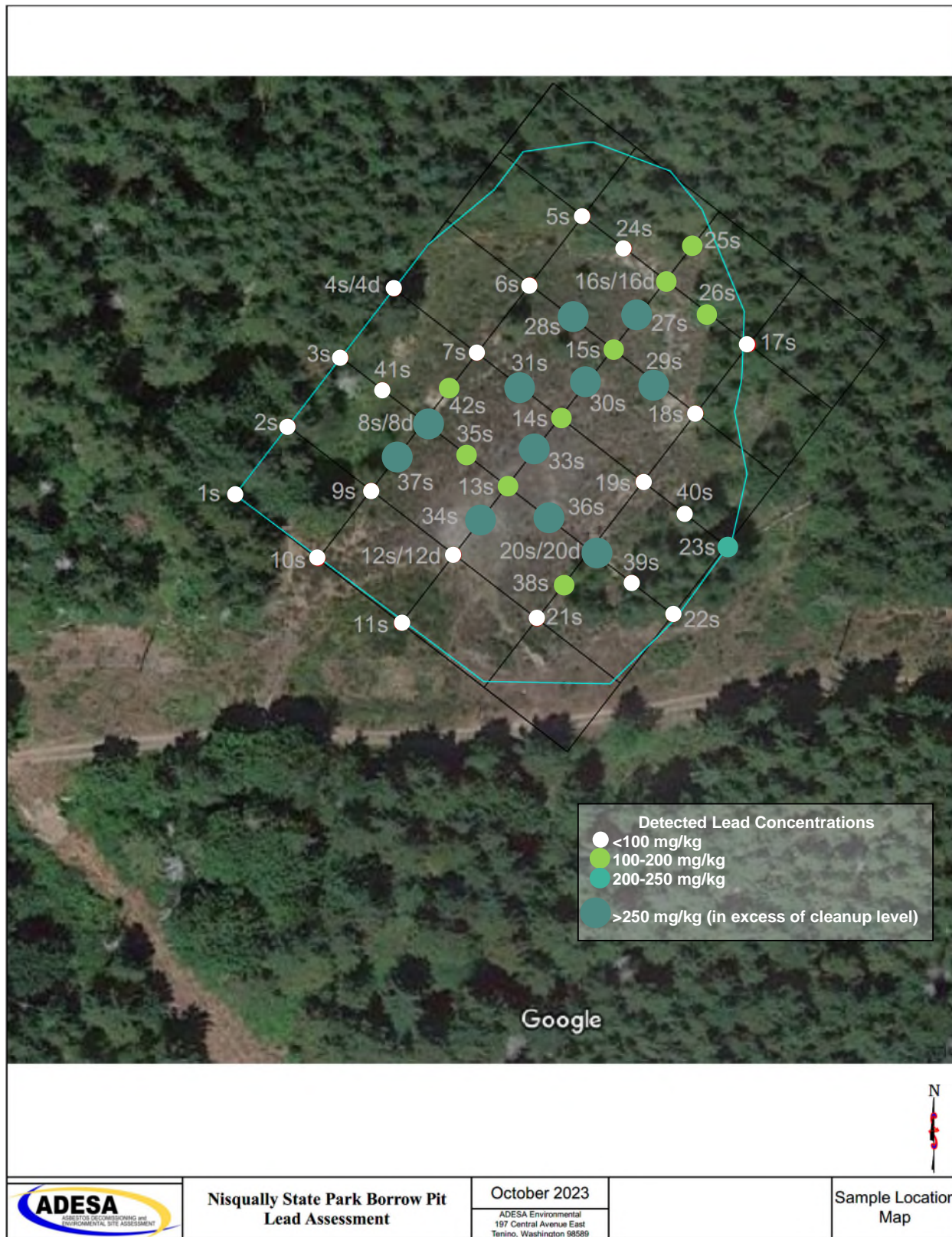



References

Pierce County Public GIS Online Property Information for Subject Property. March 2023.

Washington State Department of Ecology. 1995. Guidance on Sampling and Data Analysis Methods – Publication 94-49. January.

Washington State Department of Ecology. Washington Administrative Code 173-340, Washington State Model Toxics Control Act (MTCA). 2013.

Washington State Department of Ecology (WDOE). Washington State Everett and Tacoma Smelter Search Map. <https://fortress.wa.gov/ecy/smeltersearch/>. February 2023



APPENDIX A
LABORATORY DOCUMENTATION



Libby Environmental, Inc.

3322 South Bay Road NE • Olympia, WA 98506-2957

Phone (360) 352-2110 • libbyenv@gmail.com

November 13, 2023

Will Rutherford
ADESA
197 Central Avenue E
Tenino, WA 98589

RE: NSP - Gravel Pit
Work Order Number: L23J064

Enclosed are the results of analyses for samples received by our laboratory on 10/13/2023.

Applicable detection limits and QA/QC data are included. The sample(s) will be disposed of within 30 days unless we are contacted to arrange long term storage.

Libby Environmental, Inc. appreciates the opportunity to have provided analytical services for this project. If you have any further questions about the data report, please feel free to contact us. It was a pleasure working with you on this project, and we are looking forward to the next opportunity to work together.

Sincerely,

Sherry Chilcutt
Senior Chemist



Libby Environmental, Inc.

ADESA
197 Central Avenue E
Tenino, WA 98589

Project: NSP - Gravel Pit
Project Number: 0223-03
Project Manager: Will Rutherford

City/State: Eatonville, WA
Work Order: L23J064
Reported: 11/13/2023 15:53

Notes and Definitions

Item	Definition
RL	Reporting Limit
ND	Analyte NOT DETECTED at or above the reporting limit
DET	Analyte DETECTED at or above the reporting limit
Qual	Qualifier

All results reported on an "as received" basis unless indicated by "Dry"

Work Order Sample Summary

Lab ID	Sample	Matrix	Date Sampled	Date Received
L23J064-01	24s	Soil	10/12/2023	10/13/2023
L23J064-02	25s	Soil	10/12/2023	10/13/2023
L23J064-03	26s	Soil	10/12/2023	10/13/2023
L23J064-04	27s	Soil	10/12/2023	10/13/2023
L23J064-05	28s	Soil	10/12/2023	10/13/2023
L23J064-06	29s	Soil	10/12/2023	10/13/2023
L23J064-07	30s	Soil	10/12/2023	10/13/2023
L23J064-08	31s	Soil	10/12/2023	10/13/2023
L23J064-09	33s	Soil	10/12/2023	10/13/2023
L23J064-10	34s	Soil	10/12/2023	10/13/2023
L23J064-11	35s	Soil	10/12/2023	10/13/2023
L23J064-12	36s	Soil	10/12/2023	10/13/2023
L23J064-13	37s	Soil	10/12/2023	10/13/2023
L23J064-14	38s	Soil	10/12/2023	10/13/2023
L23J064-15	39s	Soil	10/12/2023	10/13/2023
L23J064-16	40s	Soil	10/12/2023	10/13/2023
L23J064-17	41s	Soil	10/12/2023	10/13/2023
L23J064-18	42s	Soil	10/12/2023	10/13/2023
L23J064-19	9s	Soil	10/12/2023	10/13/2023
L23J064-20	18s	Soil	10/12/2023	10/13/2023



Libby Environmental, Inc.

ADESA
197 Central Avenue E
Tenino, WA 98589

Project: NSP - Gravel Pit
Project Number: 0223-03
Project Manager: Will Rutherford

City/State: Eatonville, WA
Work Order: L23J064
Reported: 11/13/2023 15:53

Libby Environmental, Inc.

3322 South Bay Road NE

Olympia, WA 98506

Phone: (360) 352-2110

FAX: (360) 352-4154

Email: libbyenv@gmail.com

NSP - Gravel Pit Project

ADESA

Libby Work Order # L23J064

Date Received 10/13/2023

Time Received 11:50 AM

Received By AA

Sample Receipt Checklist

Chain of Custody

1. Is the Chain of Custody is complete? Yes No
2. How was the sample delivered? Hand Delivered Picked Up Shipped

Log In

3. Cooler or Shipping Container is present. Yes No N/A
4. Cooler or Shipping Container is in good condition. Yes No N/A
5. Cooler or Shipping Container has Custody Seals present. Yes No N/A
6. Was an attempt made to cool the samples? Yes No N/A
7. Temperature of cooler (0°C to 8°C recommended) 2.3 °C
8. Temperature of sample(s) (0°C to 8°C recommended) 1.7 °C
9. Did all containers arrive in good condition (unbroken)? Yes No
10. Is it clear what analyses were requested? Yes No
11. Did container labels match Chain of Custody? Yes No
12. Are matrices correctly identified on Chain of Custody? Yes No
13. Are correct containers used for the analysis indicated? Yes No
14. Is there sufficient sample volume for indicated analysis? Yes No
15. Were all containers properly preserved per each analysis? Yes No
16. Were VOA vials collected correctly (no headspace)? Yes No N/A
17. Were all holding times able to be met? Yes No

Discrepancies/ Notes

18. Was client notified of all discrepancies? Yes No N/A

Person Notified: _____

Date: _____

By Whom: _____

Via: _____

Regarding: _____

19. Comments. _____

FRIEDMAN & BRUYA, INC.

ENVIRONMENTAL CHEMISTS

James E. Bruya, Ph.D.
Yelena Aravkina, M.S.
Michael Erdahl, B.S.
Vineta Mills, M.S.
Eric Young, B.S.

5500 4th Avenue South
Seattle, WA 98108
(206) 285-8282
fbi@isomedia.com
www.friedmanandbruya.com

October 25, 2023

Sherry Chilcutt, Project Manager
Libby Environmental
3322 South Bay Rd NE
Olympia, WA 98506

Dear Ms Chilcutt:

Included are the results from the testing of material submitted on October 18, 2023 from the NSP Gravel Pit, F&BI 310339 project. There are 24 pages included in this report. Any samples that may remain are currently scheduled for disposal in 30 days, or as directed by the Chain of Custody document. If you would like us to return your samples or arrange for long term storage at our offices, please contact us as soon as possible.

We appreciate this opportunity to be of service to you and hope you will call if you should have any questions.

Sincerely,

FRIEDMAN & BRUYA, INC.



Michael Erdahl
Project Manager

Enclosures
LBY1025R.DOC

FRIEDMAN & BRUYA, INC.

ENVIRONMENTAL CHEMISTS

CASE NARRATIVE

This case narrative encompasses samples received on October 18, 2023 by Friedman & Bruya, Inc. from the Libby Environmental NSP Gravel Pit, F&BI 310339 project. Samples were logged in under the laboratory ID's listed below.

<u>Laboratory ID</u>	<u>Libby Environmental</u>
310339 -01	24S
310339 -02	25S
310339 -03	26S
310339 -04	27S
310339 -05	28S
310339 -06	29S
310339 -07	30S
310339 -08	31S
310339 -09	33S
310339 -10	34S
310339 -11	35S
310339 -12	36S
310339 -13	37S
310339 -14	38S
310339 -15	39S
310339 -16	40S
310339 -17	41S
310339 -18	42S
310339 -19	9S
310339 -20	18S

All quality control requirements were acceptable.

FRIEDMAN & BRUYA, INC.

ENVIRONMENTAL CHEMISTS

Analysis For Total Metals By EPA Method 6020B

Client ID:	24S	Client:	Libby Environmental
Date Received:	10/18/23	Project:	NSP Gravel Pit, F&BI 310339
Date Extracted:	10/19/23	Lab ID:	310339-01
Date Analyzed:	10/19/23	Data File:	310339-01.148
Matrix:	Soil	Instrument:	ICPMS2
Units:	mg/kg (ppm) Dry Weight	Operator:	SP

Analyte:	Concentration mg/kg (ppm)
----------	------------------------------

Lead	70.8
------	------

FRIEDMAN & BRUYA, INC.

ENVIRONMENTAL CHEMISTS

Analysis For Total Metals By EPA Method 6020B

Client ID:	25S	Client:	Libby Environmental
Date Received:	10/18/23	Project:	NSP Gravel Pit, F&BI 310339
Date Extracted:	10/19/23	Lab ID:	310339-02 x5
Date Analyzed:	10/20/23	Data File:	310339-02 x5.057
Matrix:	Soil	Instrument:	ICPMS2
Units:	mg/kg (ppm) Dry Weight	Operator:	SP

Analyte:	Concentration mg/kg (ppm)
----------	------------------------------

Lead	136
------	-----

FRIEDMAN & BRUYA, INC.

ENVIRONMENTAL CHEMISTS

Analysis For Total Metals By EPA Method 6020B

Client ID:	26S	Client:	Libby Environmental
Date Received:	10/18/23	Project:	NSP Gravel Pit, F&BI 310339
Date Extracted:	10/19/23	Lab ID:	310339-03 x5
Date Analyzed:	10/20/23	Data File:	310339-03 x5.060
Matrix:	Soil	Instrument:	ICPMS2
Units:	mg/kg (ppm) Dry Weight	Operator:	SP

Analyte:	Concentration mg/kg (ppm)
----------	------------------------------

Lead	151
------	-----

FRIEDMAN & BRUYA, INC.

ENVIRONMENTAL CHEMISTS

Analysis For Total Metals By EPA Method 6020B

Client ID:	27S	Client:	Libby Environmental
Date Received:	10/18/23	Project:	NSP Gravel Pit, F&BI 310339
Date Extracted:	10/19/23	Lab ID:	310339-04 x100
Date Analyzed:	10/20/23	Data File:	310339-04 x100.061
Matrix:	Soil	Instrument:	ICPMS2
Units:	mg/kg (ppm) Dry Weight	Operator:	SP

Analyte:	Concentration mg/kg (ppm)
----------	------------------------------

Lead	7,990
------	-------

FRIEDMAN & BRUYA, INC.

ENVIRONMENTAL CHEMISTS

Analysis For Total Metals By EPA Method 6020B

Client ID:	28S	Client:	Libby Environmental
Date Received:	10/18/23	Project:	NSP Gravel Pit, F&BI 310339
Date Extracted:	10/19/23	Lab ID:	310339-05 x10
Date Analyzed:	10/20/23	Data File:	310339-05 x10.062
Matrix:	Soil	Instrument:	ICPMS2
Units:	mg/kg (ppm) Dry Weight	Operator:	SP

Analyte:	Concentration mg/kg (ppm)
----------	------------------------------

Lead	848
------	-----

FRIEDMAN & BRUYA, INC.

ENVIRONMENTAL CHEMISTS

Analysis For Total Metals By EPA Method 6020B

Client ID:	29S	Client:	Libby Environmental
Date Received:	10/18/23	Project:	NSP Gravel Pit, F&BI 310339
Date Extracted:	10/19/23	Lab ID:	310339-06 x10
Date Analyzed:	10/20/23	Data File:	310339-06 x10.063
Matrix:	Soil	Instrument:	ICPMS2
Units:	mg/kg (ppm) Dry Weight	Operator:	SP

Analyte:	Concentration mg/kg (ppm)
----------	------------------------------

Lead	509
------	-----

FRIEDMAN & BRUYA, INC.

ENVIRONMENTAL CHEMISTS

Analysis For Total Metals By EPA Method 6020B

Client ID:	30S	Client:	Libby Environmental
Date Received:	10/18/23	Project:	NSP Gravel Pit, F&BI 310339
Date Extracted:	10/19/23	Lab ID:	310339-07 x5
Date Analyzed:	10/20/23	Data File:	310339-07 x5.064
Matrix:	Soil	Instrument:	ICPMS2
Units:	mg/kg (ppm) Dry Weight	Operator:	SP

Analyte:	Concentration mg/kg (ppm)
----------	------------------------------

Lead	318
------	-----

FRIEDMAN & BRUYA, INC.

ENVIRONMENTAL CHEMISTS

Analysis For Total Metals By EPA Method 6020B

Client ID:	31S	Client:	Libby Environmental
Date Received:	10/18/23	Project:	NSP Gravel Pit, F&BI 310339
Date Extracted:	10/19/23	Lab ID:	310339-08 x5
Date Analyzed:	10/20/23	Data File:	310339-08 x5.065
Matrix:	Soil	Instrument:	ICPMS2
Units:	mg/kg (ppm) Dry Weight	Operator:	SP

Analyte:	Concentration mg/kg (ppm)
----------	------------------------------

Lead	336
------	-----

FRIEDMAN & BRUYA, INC.

ENVIRONMENTAL CHEMISTS

Analysis For Total Metals By EPA Method 6020B

Client ID:	33S	Client:	Libby Environmental
Date Received:	10/18/23	Project:	NSP Gravel Pit, F&BI 310339
Date Extracted:	10/19/23	Lab ID:	310339-09 x25
Date Analyzed:	10/20/23	Data File:	310339-09 x25.066
Matrix:	Soil	Instrument:	ICPMS2
Units:	mg/kg (ppm) Dry Weight	Operator:	SP

Analyte:	Concentration mg/kg (ppm)
----------	------------------------------

Lead	2,230
------	-------

FRIEDMAN & BRUYA, INC.

ENVIRONMENTAL CHEMISTS

Analysis For Total Metals By EPA Method 6020B

Client ID:	34S	Client:	Libby Environmental
Date Received:	10/18/23	Project:	NSP Gravel Pit, F&BI 310339
Date Extracted:	10/19/23	Lab ID:	310339-10 x5
Date Analyzed:	10/20/23	Data File:	310339-10 x5.067
Matrix:	Soil	Instrument:	ICPMS2
Units:	mg/kg (ppm) Dry Weight	Operator:	SP

Analyte:	Concentration mg/kg (ppm)
----------	------------------------------

Lead	467
------	-----

FRIEDMAN & BRUYA, INC.

ENVIRONMENTAL CHEMISTS

Analysis For Total Metals By EPA Method 6020B

Client ID:	35S	Client:	Libby Environmental
Date Received:	10/18/23	Project:	NSP Gravel Pit, F&BI 310339
Date Extracted:	10/19/23	Lab ID:	310339-11 x2
Date Analyzed:	10/20/23	Data File:	310339-11 x2.068
Matrix:	Soil	Instrument:	ICPMS2
Units:	mg/kg (ppm) Dry Weight	Operator:	SP

Analyte:	Concentration mg/kg (ppm)
----------	------------------------------

Lead	110
------	-----

FRIEDMAN & BRUYA, INC.

ENVIRONMENTAL CHEMISTS

Analysis For Total Metals By EPA Method 6020B

Client ID:	36S	Client:	Libby Environmental
Date Received:	10/18/23	Project:	NSP Gravel Pit, F&BI 310339
Date Extracted:	10/19/23	Lab ID:	310339-12 x5
Date Analyzed:	10/20/23	Data File:	310339-12 x5.069
Matrix:	Soil	Instrument:	ICPMS2
Units:	mg/kg (ppm) Dry Weight	Operator:	SP

Analyte:	Concentration mg/kg (ppm)
----------	------------------------------

Lead	267
------	-----

FRIEDMAN & BRUYA, INC.

ENVIRONMENTAL CHEMISTS

Analysis For Total Metals By EPA Method 6020B

Client ID:	37S	Client:	Libby Environmental
Date Received:	10/18/23	Project:	NSP Gravel Pit, F&BI 310339
Date Extracted:	10/19/23	Lab ID:	310339-13 x5
Date Analyzed:	10/20/23	Data File:	310339-13 x5.072
Matrix:	Soil	Instrument:	ICPMS2
Units:	mg/kg (ppm) Dry Weight	Operator:	SP

Analyte:	Concentration mg/kg (ppm)
----------	------------------------------

Lead	549
------	-----

FRIEDMAN & BRUYA, INC.

ENVIRONMENTAL CHEMISTS

Analysis For Total Metals By EPA Method 6020B

Client ID:	38S	Client:	Libby Environmental
Date Received:	10/18/23	Project:	NSP Gravel Pit, F&BI 310339
Date Extracted:	10/19/23	Lab ID:	310339-14 x5
Date Analyzed:	10/20/23	Data File:	310339-14 x5.073
Matrix:	Soil	Instrument:	ICPMS2
Units:	mg/kg (ppm) Dry Weight	Operator:	SP

Analyte:	Concentration mg/kg (ppm)
----------	------------------------------

Lead	164
------	-----

FRIEDMAN & BRUYA, INC.

ENVIRONMENTAL CHEMISTS

Analysis For Total Metals By EPA Method 6020B

Client ID:	39S	Client:	Libby Environmental
Date Received:	10/18/23	Project:	NSP Gravel Pit, F&BI 310339
Date Extracted:	10/19/23	Lab ID:	310339-15
Date Analyzed:	10/20/23	Data File:	310339-15.076
Matrix:	Soil	Instrument:	ICPMS2
Units:	mg/kg (ppm) Dry Weight	Operator:	SP

Analyte:	Concentration mg/kg (ppm)
----------	------------------------------

Lead	20.3
------	------

FRIEDMAN & BRUYA, INC.

ENVIRONMENTAL CHEMISTS

Analysis For Total Metals By EPA Method 6020B

Client ID:	40S	Client:	Libby Environmental
Date Received:	10/18/23	Project:	NSP Gravel Pit, F&BI 310339
Date Extracted:	10/19/23	Lab ID:	310339-16
Date Analyzed:	10/20/23	Data File:	310339-16.079
Matrix:	Soil	Instrument:	ICPMS2
Units:	mg/kg (ppm) Dry Weight	Operator:	SP

Analyte:	Concentration mg/kg (ppm)
----------	------------------------------

Lead	12.9
------	------

FRIEDMAN & BRUYA, INC.

ENVIRONMENTAL CHEMISTS

Analysis For Total Metals By EPA Method 6020B

Client ID:	41S	Client:	Libby Environmental
Date Received:	10/18/23	Project:	NSP Gravel Pit, F&BI 310339
Date Extracted:	10/19/23	Lab ID:	310339-17
Date Analyzed:	10/20/23	Data File:	310339-17.080
Matrix:	Soil	Instrument:	ICPMS2
Units:	mg/kg (ppm) Dry Weight	Operator:	SP

Analyte:	Concentration mg/kg (ppm)
----------	------------------------------

Lead	41.7
------	------

FRIEDMAN & BRUYA, INC.

ENVIRONMENTAL CHEMISTS

Analysis For Total Metals By EPA Method 6020B

Client ID:	42S	Client:	Libby Environmental
Date Received:	10/18/23	Project:	NSP Gravel Pit, F&BI 310339
Date Extracted:	10/19/23	Lab ID:	310339-18 x5
Date Analyzed:	10/20/23	Data File:	310339-18 x5.081
Matrix:	Soil	Instrument:	ICPMS2
Units:	mg/kg (ppm) Dry Weight	Operator:	SP

Analyte:	Concentration mg/kg (ppm)
----------	------------------------------

Lead	158
------	-----

FRIEDMAN & BRUYA, INC.

ENVIRONMENTAL CHEMISTS

Analysis For Total Metals By EPA Method 6020B

Client ID:	9S	Client:	Libby Environmental
Date Received:	10/18/23	Project:	NSP Gravel Pit, F&BI 310339
Date Extracted:	10/19/23	Lab ID:	310339-19
Date Analyzed:	10/20/23	Data File:	310339-19.125
Matrix:	Soil	Instrument:	ICPMS2
Units:	mg/kg (ppm) Dry Weight	Operator:	SP

Analyte:	Concentration mg/kg (ppm)
----------	------------------------------

Lead	24.7
------	------

FRIEDMAN & BRUYA, INC.

ENVIRONMENTAL CHEMISTS

Analysis For Total Metals By EPA Method 6020B

Client ID:	18S	Client:	Libby Environmental
Date Received:	10/18/23	Project:	NSP Gravel Pit, F&BI 310339
Date Extracted:	10/19/23	Lab ID:	310339-20
Date Analyzed:	10/20/23	Data File:	310339-20.128
Matrix:	Soil	Instrument:	ICPMS2
Units:	mg/kg (ppm) Dry Weight	Operator:	SP

Analyte:	Concentration mg/kg (ppm)
----------	------------------------------

Lead	9.31
------	------

FRIEDMAN & BRUYA, INC.

ENVIRONMENTAL CHEMISTS

Analysis For Total Metals By EPA Method 6020B

Client ID:	Method Blank	Client:	Libby Environmental
Date Received:	Not Applicable	Project:	NSP Gravel Pit, F&BI 310339
Date Extracted:	10/19/23	Lab ID:	I3-833 mb
Date Analyzed:	10/19/23	Data File:	I3-833 mb.146
Matrix:	Soil	Instrument:	ICPMS2
Units:	mg/kg (ppm) Dry Weight	Operator:	SP

Analyte:	Concentration mg/kg (ppm)
----------	------------------------------

Lead	<1
------	----

FRIEDMAN & BRUYA, INC.

ENVIRONMENTAL CHEMISTS

Date of Report: 10/25/23

Date Received: 10/18/23

Project: NSP Gravel Pit, F&BI 310339

**QUALITY ASSURANCE RESULTS
FOR THE ANALYSIS OF SOIL SAMPLES
FOR TOTAL METALS USING EPA METHOD 6020B**

Laboratory Code: 310339-01 (Matrix Spike)

Analyte	Reporting Units	Spike Level	Sample Result (Wet wt)	Percent Recovery MS	Percent Recovery MSD	Acceptance Criteria	RPD (Limit 20)
Lead	mg/kg (ppm)	50	61.6	309 b	99 b	75-125	103 b

Laboratory Code: Laboratory Control Sample

Analyte	Reporting Units	Spike Level	Percent Recovery LCS	Acceptance Criteria
Lead	mg/kg (ppm)	50	98	80-120

Data Qualifiers & Definitions

- a - The analyte was detected at a level less than five times the reporting limit. The RPD results may not provide reliable information on the variability of the analysis.
- b - The analyte was spiked at a level that was less than five times that present in the sample. Matrix spike recoveries may not be meaningful.
- ca - The calibration results for the analyte were outside of acceptance criteria, biased low; or, the calibration results for the analyte were outside of acceptance criteria, biased high, with a detection for the analyte in the sample. The value reported is an estimate.
- c - The presence of the analyte may be due to carryover from previous sample injections.
- cf - The sample was centrifuged prior to analysis.
- d - The sample was diluted. Detection limits were raised and surrogate recoveries may not be meaningful.
- dv - Insufficient sample volume was available to achieve normal reporting limits.
- f - The sample was laboratory filtered prior to analysis.
- fb - The analyte was detected in the method blank.
- fc - The analyte is a common laboratory and field contaminant.
- hr - The sample and duplicate were reextracted and reanalyzed. RPD results were still outside of control limits. Variability is attributed to sample inhomogeneity.
- hs - Headspace was present in the container used for analysis.
- ht - The analysis was performed outside the method or client-specified holding time requirement.
- ip - Recovery fell outside of control limits due to sample matrix effects.
- j - The analyte concentration is reported below the standard reporting limit. The value reported is an estimate.
- J - The internal standard associated with the analyte is out of control limits. The reported concentration is an estimate.
- jl - The laboratory control sample(s) percent recovery and/or RPD were out of control limits. The reported concentration should be considered an estimate.
- js - The surrogate associated with the analyte is out of control limits. The reported concentration should be considered an estimate.
- k - The calibration results for the analyte were outside of acceptance criteria, biased high, and the analyte was not detected in the sample.
- lc - The presence of the analyte is likely due to laboratory contamination.
- L - The reported concentration was generated from a library search.
- nm - The analyte was not detected in one or more of the duplicate analyses. Therefore, calculation of the RPD is not applicable.
- pc - The sample was received with incorrect preservation or in a container not approved by the method. The value reported should be considered an estimate.
- ve - The analyte response exceeded the valid instrument calibration range. The value reported is an estimate.
- vo - The value reported fell outside the control limits established for this analyte.
- x - The sample chromatographic pattern does not resemble the fuel standard used for quantitation.



Libby Environmental, Inc.

3322 South Bay Road NE • Olympia, WA 98506-2957

**SUBCONTRACT
ORDER
L23J064**

310339

10/18/23

M2

Sending Laboratory:

Subcontracted Laboratory:

Libby Environmental, Inc.
3322 South Bay Road NE
Olympia, WA 98506
Phone: 360-352-2110
Fax: 360-352-4154

Project Manager: Sherry Chilcutt
LibbyEnv@gmail.com

Friedman & Bruya, Inc.
5500 4th Avenue S
Seattle, WA 98108
Phone: (206) 285-8282
Fax:

Requested Turnaround (TAT) STD

Project: NSP - Gravel Pit

Analysis	Comments	LabID	
Client Sample ID: 24s Soil Sampled: 10/12/2023 00:00		01	Lab ID: L23J064-01
Metals SUB Pb	6000 Series		
Containers Supplied: 402 jars			
Client Sample ID: 25s Soil Sampled: 10/12/2023 00:00		02	Lab ID: L23J064-02
Metals SUB Pb	6000 Series		
Containers Supplied:			
Client Sample ID: 26s Soil Sampled: 10/12/2023 00:00		03	Lab ID: L23J064-03
Metals SUB Pb	6000 Series		
Containers Supplied:			
Client Sample ID: 27s Soil Sampled: 10/12/2023 00:00		04	Lab ID: L23J064-04
Metals SUB Pb	6000 Series		
Containers Supplied:			
Client Sample ID: 28s Soil Sampled: 10/12/2023 00:00		05	Lab ID: L23J064-05
Metals SUB Pb	6000 Series		
Containers Supplied:			
Client Sample ID: 29s Soil Sampled: 10/12/2023 00:00		06	Lab ID: L23J064-06
Metals SUB Pb	6000 Series		
Containers Supplied:			

Samples received at 1 °C

Esantor

10/16/23
Date

Received By

10/18/23
Date @ 11:04



Libby Environmental, Inc.

3322 South Bay Road NE • Olympia, WA 98506-2957

**SUBCONTRACT
ORDER
L23J064**

(Continued)

310339

10/18/23 M2

Project: NSP - Gravel Pit

Analysis	Comments	Lab ID
Client Sample ID: 30s Soil Sampled: 10/12/2023 00:00		07 Lab ID: L23J064-07
Metals SUB Pb	6000 Series	
<i>Containers Supplied:</i>		
Client Sample ID: 31s Soil Sampled: 10/12/2023 00:00		08 Lab ID: L23J064-08
Metals SUB Pb	6000 Series	
<i>Containers Supplied:</i>		
Client Sample ID: 33s Soil Sampled: 10/12/2023 00:00		09 Lab ID: L23J064-09
Metals SUB Pb	6000 Series	
<i>Containers Supplied:</i>		
Client Sample ID: 34s Soil Sampled: 10/12/2023 00:00		10 Lab ID: L23J064-10
Metals SUB Pb	6000 Series	
<i>Containers Supplied:</i>		
Client Sample ID: 35s Soil Sampled: 10/12/2023 00:00		11 Lab ID: L23J064-11
Metals SUB Pb	6000 Series	
<i>Containers Supplied:</i>		
Client Sample ID: 36s Soil Sampled: 10/12/2023 00:00		12 Lab ID: L23J064-12
Metals SUB Pb	6000 Series	
<i>Containers Supplied:</i>		
Client Sample ID: 37s Soil Sampled: 10/12/2023 00:00		13 Lab ID: L23J064-13
Metals SUB Pb	6000 Series	
<i>Containers Supplied:</i>		
Client Sample ID: 38s Soil Sampled: 10/12/2023 00:00		14 Lab ID: L23J064-14
Metals SUB Pb	6000 Series	
<i>Containers Supplied:</i>		

Samples received at 1 °C

E. Senter
Released By

10/16/23
Date

[Signature]
Received By

10/18/23
Date
@ 11:04



Libby Environmental, Inc.

3322 South Bay Road NE • Olympia, WA 98506-2957

**SUBCONTRACT
ORDER
L23J064**

(Continued)

310339

Project: NSP - Gravel Pit

10/18/23

Ma

Analysis	Comments	Lab ID
Client Sample ID: 39s Soil Sampled: 10/12/2023 00:00 Metals SUB Pb Containers Supplied:	6000 Series	15 Lab ID: L23J064-15
Client Sample ID: 40s Soil Sampled: 10/12/2023 00:00 Metals SUB Pb Containers Supplied:	6000 Series	16 Lab ID: L23J064-16
Client Sample ID: 41s Soil Sampled: 10/12/2023 00:00 Metals SUB Pb Containers Supplied:	6000 Series	17 Lab ID: L23J064-17
Client Sample ID: 42s Soil Sampled: 10/12/2023 00:00 Metals SUB Pb Containers Supplied:	6000 Series	18 Lab ID: L23J064-18
Client Sample ID: 9s Soil Sampled: 10/12/2023 00:00 Metals SUB Pb Containers Supplied:	6000 Series	19 Lab ID: L23J064-19
Client Sample ID: 18s Soil Sampled: 10/12/2023 00:00 Metals SUB Pb Containers Supplied:	6000 Series	20 Lab ID: L23J064-20

Samples received at 1 °C

E Santor
Released By

10/16/23
Date

[Signature]
Received By

10/18/23
Date
@ 11:04



3600 Fremont Ave. N.

Seattle, WA 98103

T: (206) 352-3790

F: (206) 352-7178

info@fremontanalytical.com

Friedman & Bruya

Michael Erdahl

5500 4th Ave S

Seattle, WA 98108

RE: 310339

Work Order Number: 2311218

November 13, 2023

Attention Michael Erdahl:

Fremont Analytical, Inc. received 2 sample(s) on 11/9/2023 for the analyses presented in the following report.

Metals (EPA 6020B) with TCLP Extraction (EPA 1311)

This report consists of the following:

- Case Narrative
- Analytical Results
- Applicable Quality Control Summary Reports
- Chain of Custody

All analyses were performed consistent with the Quality Assurance program of Fremont Analytical, Inc. Please contact the laboratory if you should have any questions about the results.

Thank you for using Fremont Analytical.

Sincerely,

Brianna Barnes
Project Manager

*DoD-ELAP Accreditation #79636 by PJLA, ISO/IEC 17025:2017 and QSM 5.3 for Environmental Testing
ORELAP Certification: WA 100009 (NELAP Recognized) for Environmental Testing
Washington State Department of Ecology Accredited for Environmental Testing, Lab ID C910*

Original

www.fremontanalytical.com

CLIENT: Friedman & Bruya
Project: 310339
Work Order: 2311218

Work Order Sample Summary

Lab Sample ID	Client Sample ID	Date/Time Collected	Date/Time Received
2311218-001	27S	10/12/2023 12:00 AM	11/09/2023 1:50 PM
2311218-002	33S	10/12/2023 12:00 AM	11/09/2023 1:50 PM

Note: If no "Time Collected" is supplied, a default of 12:00AM is assigned

Original

CLIENT: Friedman & Bruya

Project: 310339

I. SAMPLE RECEIPT:

Samples receipt information is recorded on the attached Sample Receipt Checklist.

II. GENERAL REPORTING COMMENTS:

Results are reported on a wet weight basis unless dry-weight correction is denoted in the units field on the analytical report ("mg/kg-dry" or "ug/kg-dry").

Matrix Spike (MS) and MS Duplicate (MSD) samples are tested from an analytical batch of "like" matrix to check for possible matrix effect. The MS and MSD will provide site specific matrix data only for those samples which are spiked by the laboratory. The sample chosen for spike purposes may or may not have been a sample submitted in this sample delivery group. The validity of the analytical procedures for which data is reported in this analytical report is determined by the Laboratory Control Sample (LCS) and the Method Blank (MB). The LCS and the MB are processed with the samples and the MS/MSD to ensure method criteria are achieved throughout the entire analytical process.

III. ANALYSES AND EXCEPTIONS:

Exceptions associated with this report will be footnoted in the analytical results page(s) or the quality control summary page(s) and/or noted below.

Qualifiers:

- * - Flagged value is not within established control limits
- B - Analyte detected in the associated Method Blank
- D - Dilution was required
- E - Value above quantitation range
- H - Holding times for preparation or analysis exceeded
- I - Analyte with an internal standard that does not meet established acceptance criteria
- J - Analyte detected below Reporting Limit
- N - Tentatively Identified Compound (TIC)
- Q - Analyte with an initial or continuing calibration that does not meet established acceptance criteria
- S - Spike recovery outside accepted recovery limits
- ND - Not detected at the Reporting Limit
- R - High relative percent difference observed

Acronyms:

- %Rec - Percent Recovery
- CCB - Continued Calibration Blank
- CCV - Continued Calibration Verification
- DF - Dilution Factor
- DUP - Sample Duplicate
- HEM - Hexane Extractable Material
- ICV - Initial Calibration Verification
- LCS/LCSD - Laboratory Control Sample / Laboratory Control Sample Duplicate
- MCL - Maximum Contaminant Level
- MB or MBLANK - Method Blank
- MDL - Method Detection Limit
- MS/MSD - Matrix Spike / Matrix Spike Duplicate
- PDS - Post Digestion Spike
- Ref Val - Reference Value
- REP - Sample Replicate
- RL - Reporting Limit
- RPD - Relative Percent Difference
- SD - Serial Dilution
- SGT - Silica Gel Treatment
- SPK - Spike
- Surr - Surrogate



Analytical Report

Work Order: 2311218
Date Reported: 11/13/2023

CLIENT: Friedman & Bruya
Project: 310339

Lab ID: 2311218-001
Client Sample ID: 27S

Collection Date: 10/12/2023
Matrix: Soil

Analyses	Result	PQL	Qual	Units	DF	Date Analyzed
Metals (EPA 6020B) with TCLP Extraction (EPA 1311)				Batch ID: 42028		Analyst: JR
Lead	3.01	0.200		mg/L	1	11/13/2023 1:54:00 PM

Lab ID: 2311218-002
Client Sample ID: 33S

Collection Date: 10/12/2023
Matrix: Soil

Analyses	Result	PQL	Qual	Units	DF	Date Analyzed
Metals (EPA 6020B) with TCLP Extraction (EPA 1311)				Batch ID: 42028		Analyst: JR
Lead	17.1	1.00	D	mg/L	5	11/13/2023 2:32:00 PM

Work Order: 2311218
CLIENT: Friedman & Bruya
Project: 310339

QC SUMMARY REPORT

Metals (EPA 6020B) with TCLP Extraction (EPA 1311)

Sample ID: MB-42028	SampType: MBLK	Units: mg/L	Prep Date: 11/13/2023	RunNo: 87734							
Client ID: MBLKS	Batch ID: 42028	Analysis Date: 11/13/2023	SeqNo: 1831465								
Analyte	Result	RL	SPK value	SPK Ref Val	%REC	LowLimit	HighLimit	RPD Ref Val	%RPD	RPDLimit	Qual

Lead ND 0.200

Sample ID: LCS-42028	SampType: LCS	Units: mg/L	Prep Date: 11/13/2023	RunNo: 87734							
Client ID: LCSS	Batch ID: 42028	Analysis Date: 11/13/2023	SeqNo: 1831466								
Analyte	Result	RL	SPK value	SPK Ref Val	%REC	LowLimit	HighLimit	RPD Ref Val	%RPD	RPDLimit	Qual

Lead 2.54 0.200 2.500 0 102 65 135

Sample ID: 2311218-001ADUP	SampType: DUP	Units: mg/L	Prep Date: 11/13/2023	RunNo: 87734							
Client ID: 27S	Batch ID: 42028	Analysis Date: 11/13/2023	SeqNo: 1831468								
Analyte	Result	RL	SPK value	SPK Ref Val	%REC	LowLimit	HighLimit	RPD Ref Val	%RPD	RPDLimit	Qual

Lead 2.81 0.200 3.012 7.04 30

Sample ID: 2311218-001AMS	SampType: MS	Units: mg/L	Prep Date: 11/13/2023	RunNo: 87734							
Client ID: 27S	Batch ID: 42028	Analysis Date: 11/13/2023	SeqNo: 1831485								
Analyte	Result	RL	SPK value	SPK Ref Val	%REC	LowLimit	HighLimit	RPD Ref Val	%RPD	RPDLimit	Qual

Lead 5.38 0.200 2.500 3.012 94.8 65 135

Sample ID: 2311218-001AMSD	SampType: MSD	Units: mg/L	Prep Date: 11/13/2023	RunNo: 87734							
Client ID: 27S	Batch ID: 42028	Analysis Date: 11/13/2023	SeqNo: 1831486								
Analyte	Result	RL	SPK value	SPK Ref Val	%REC	LowLimit	HighLimit	RPD Ref Val	%RPD	RPDLimit	Qual

Lead 5.70 0.200 2.500 3.012 108 65 135 5.383 5.73 30

Client Name: FB	Work Order Number: 2311218
Logged by: Morgan Wilson	Date Received: 11/9/2023 1:50:00 PM

Chain of Custody

1. Is Chain of Custody complete? Yes No Not Present
2. How was the sample delivered? Client

Log In

3. Custody Seals present on shipping container/cooler?
(Refer to comments for Custody Seals not intact) Yes No Not Present
4. Was an attempt made to cool the samples? Yes No NA
5. Were all items received at a temperature of >2°C to 6°C * Yes No NA
6. Sample(s) in proper container(s)? Yes No
7. Sufficient sample volume for indicated test(s)? Yes No
8. Are samples properly preserved? Yes No
9. Was preservative added to bottles? Yes No NA
10. Is there headspace in the VOA vials? Yes No NA
11. Did all samples containers arrive in good condition(unbroken)? Yes No
12. Does paperwork match bottle labels? Yes No
13. Are matrices correctly identified on Chain of Custody? Yes No
14. Is it clear what analyses were requested? Yes No
15. Were all hold times (except field parameters, pH e.g.) able to be met? Yes No

Special Handling (if applicable)

16. Was client notified of all discrepancies with this order? Yes No NA

Person Notified:	<input type="text"/>	Date:	<input type="text"/>
By Whom:	<input type="text"/>	Via:	<input type="checkbox"/> eMail <input type="checkbox"/> Phone <input type="checkbox"/> Fax <input type="checkbox"/> In Person
Regarding:	<input type="text"/>		
Client Instructions:	<input type="text"/>		

17. Additional remarks:

Item Information

Item #	Temp °C
Sample	1.8

* Note: DoD/ELAP and TNI require items to be received at 4°C +/- 2°C



Libby Environmental, Inc.

3322 South Bay Road NE • Olympia, WA 98506-2957

March 3, 2023

William Rutherford
ADESA
P.O. Box 1009
Tenino, WA 98589

Dear William Rutherford:

Please find enclosed the analytical data report for the NSP – Gravel Pit project located in Eatonville, Washington.

The results of the analyses are summarized in the attached tables. Applicable detection limits and QA/QC data are included. The sample(s) will be disposed of within 30 days unless we are contacted to arrange long term storage.

Libby Environmental, Inc. appreciates the opportunity to have provided analytical services for this project. If you have any further questions about the data report, please give me a call. It was a pleasure working with you on this project, and we are looking forward to the next opportunity to work together.

Sincerely,

Sherry L. Chilcutt
Senior Chemist
Libby Environmental, Inc.

Libby Environmental, Inc.

Chain of Custody Record

www.LibbyEnvironmental.com

3322 South Bay Road NE
 Olympia, WA 98506
 Ph: 360-352-2110
 Fax: 360-352-4154

Client: **ADESA**

Address: **197 Central Ave E**

City: **Tenino** State: **WA** Zip: **98589**

Phone: **360-201-8797** Fax:

Client Project # **0223-03**

Date: **2/21/2023** Page: **1** of **2**

Project Manager: **WW Rutherford**

Project Name: **NSP - Gravel Pit**

Location: **Eatonville - NSP** City, State: **Eatonville, WA**

Collector: **WW Rutherford** Date of Collection: **2/20/2023**

Email: **wutherford@adesa-wa.com**

Sample Number	Depth	Time	Sample Type	Container Type	VOC 8260	PCE & Daughter Prod.	NWTPH-Gx	BTEX (8260) / (8021)	NWTPH-HCID	NWTPH-Dx / Dx	PCB 8082	MTCA 5 Metals	RCRA 8 Metals	PAH 8270	Semi Vol 8270	Lead 6010, 6020	or 6200 per Ecology	Field Notes
1	1s	0-6in		4oz												X		
2	2s	0-6in														X		
3	3s	↓														X		
4	4s	↓														X		
5	4d	6-12in														X		
6	5s	0-6in														X		
7	6s	↓														X		
8	7s	↓														X		
9	8s	↓														X		
10	8d	6-12in														X		
11	9s	0-6in														X		Unable to perform analysis
12	10s	↓														X		sample container broke
13	11s	↓														X		at subcontracted lab.
14	12s	↓														X		
15	12d	6-12in														X		
16	13s	0-6in														X		
17	14s	↓														X		

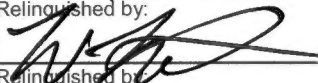
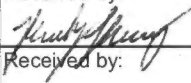
Relinquished by: 	Date / Time: 2/21/23	Received by: 	Date / Time: 2.21.23 1218	Sample Receipt		Remarks:
Relinquished by:	Date / Time:	Received by:	Date / Time:	Good Condition?	Y N	
				Cooler Temp.	°C	
				Sample Temp.	°C	
Relinquished by:	Date / Time:	Received by:	Date / Time:	Total Number of Containers		
						TAT: 24HR 48HR 5-DAY

Libby Environmental, Inc.

Chain of Custody Record

www.LibbyEnvironmental.com

3322 South Bay Road NE
Olympia, WA 98506

Ph: 360-352-2110
Fax: 360-352-4154

Date: 2/21/23 Page: 2 of 2

Client: ADESA

Project Manager: WW Rutherford

Address: 197 Central Ave E

Project Name: NSP - Gravel Pit

City: Tenino State: WA Zip: 98509

Location: Eatonville - NSP City, State: Eatonville, WA

Phone: 360-701-8797 Fax:

Collector: WW Rutherford Date of Collection: 2/20/2023

Client Project # 0223-03

Email: wutherford@adesa-wa.com

Sample Number	Depth	Time	Sample Type	Container Type	VOC 8260	PCE & Daughter Prod.	NWTPH-Gx	BTEX (8260) / (8021)	NWTPH-HCID	NWTPH-Dx / Dx	PCB 8082	MTCA 5 Metals	RCRA 8 Metals	c PAH 8270	PAH 8270	Semi Vol 8270	Lead 6010, 6020	or 6200 per Ecology	Field Notes
1	15s		0-6in														X		
2	16s		↓														X		
3	16d		6-12in														X		
4	17s		0-6in														X		
5	18s		↓														X		Unable to perform analysis
6	19s		↓														X		Sample container broke
7	20s		↓														X		at subcontracted lab.
8	20d		6-12in														X		
9	21s		0-6in														X		
10	22s		↓														X		
11	23s		↓														X		
12																			
13																			
14																			
15																			
16																			
17																			

Relinquished by: <u>[Signature]</u>	Date / Time: <u>2/21/23</u>	Received by: <u>[Signature]</u>	Date / Time: <u>2.21.23 12:18</u>	Sample Receipt Good Condition? <u>Y</u> <u>N</u> Cooler Temp. <u> </u> °C Sample Temp. <u> </u> °C Total Number of Containers <u> </u>	Remarks:
Relinquished by:	Date / Time:	Received by:	Date / Time:		
Relinquished by:	Date / Time:	Received by:	Date / Time:		

TAT: 24HR 48HR 6-DAY

Libby Environmental, Inc.

3322 South Bay Road NE

Olympia, WA 98506

Phone: (360) 352-2110

FAX: (360) 352-4154

Email: libbyenv@gmail.com

NSP - GRAVEL PIT PROJECT

ADESA

Libby Project # L23B086

Date Received 2/21/2023

Time Received 12:18 PM

Received By RJK

Sample Receipt Checklist

Chain of Custody

1. Is the Chain of Custody is complete? Yes No
2. How was the sample delivered? Hand Delivered Picked Up Shipped

Log In

3. Cooler or Shipping Container is present. Yes No N/A
4. Cooler or Shipping Container is in good condition. Yes No N/A
5. Cooler or Shipping Container has Custody Seals present. Yes No N/A
6. Was an attempt made to cool the samples? Yes No N/A
7. Temperature of cooler (0°C to 8°C recommended) 8.2 °C
8. Temperature of sample(s) (0°C to 8°C recommended) 10.1 °C
9. Did all containers arrive in good condition (unbroken)? Yes No
10. Is it clear what analyses were requested? Yes No
11. Did container labels match Chain of Custody? Yes No
12. Are matrices correctly identified on Chain of Custody? Yes No
13. Are correct containers used for the analysis indicated? Yes No
14. Is there sufficient sample volume for indicated analysis? Yes No
15. Were all containers properly preserved per each analysis? Yes No
16. Were VOA vials collected correctly (no headspace)? Yes No N/A
17. Were all holding times able to be met? Yes No

Discrepancies/ Notes

18. Was client notified of all discrepancies? Yes No N/A

Person Notified: _____

Date: _____

By Whom: _____

Via: _____

Regarding: _____

19. Comments. _____



Libby Environmental
Sherry Chilcutt
3322 South Bay Road NE
Olympia, WA 98506

RE: NSP - Gravel Pit
Work Order Number: 2302398

March 03, 2023

Attention Sherry Chilcutt:

Fremont Analytical, Inc. received 28 sample(s) on 2/22/2023 for the analyses presented in the following report.

Sample Moisture (Percent Moisture)
Total Metals by EPA Method 6020B

This report consists of the following:

- Case Narrative
- Analytical Results
- Applicable Quality Control Summary Reports
- Chain of Custody

All analyses were performed consistent with the Quality Assurance program of Fremont Analytical, Inc. Please contact the laboratory if you should have any questions about the results.

Thank you for using Fremont Analytical.

Sincerely,

Brianna Barnes
Project Manager



CLIENT: Libby Environmental
Project: NSP - Gravel Pit
Work Order: 2302398

Work Order Sample Summary

Lab Sample ID	Client Sample ID	Date/Time Collected	Date/Time Received
2302398-001	1s	02/21/2023 12:00 AM	02/22/2023 10:30 AM
2302398-002	2s	02/21/2023 12:00 AM	02/22/2023 10:30 AM
2302398-003	3s	02/21/2023 12:00 AM	02/22/2023 10:30 AM
2302398-004	4s	02/21/2023 12:00 AM	02/22/2023 10:30 AM
2302398-005	4d	02/21/2023 12:00 AM	02/22/2023 10:30 AM
2302398-006	5s	02/21/2023 12:00 AM	02/22/2023 10:30 AM
2302398-007	6s	02/21/2023 12:00 AM	02/22/2023 10:30 AM
2302398-008	7s	02/21/2023 12:00 AM	02/22/2023 10:30 AM
2302398-009	8s	02/21/2023 12:00 AM	02/22/2023 10:30 AM
2302398-010	8d	02/21/2023 12:00 AM	02/22/2023 10:30 AM
2302398-011	9s	02/21/2023 12:00 AM	02/22/2023 10:30 AM
2302398-012	10s	02/21/2023 12:00 AM	02/22/2023 10:30 AM
2302398-013	11s	02/21/2023 12:00 AM	02/22/2023 10:30 AM
2302398-014	12s	02/21/2023 12:00 AM	02/22/2023 10:30 AM
2302398-015	12d	02/21/2023 12:00 AM	02/22/2023 10:30 AM
2302398-016	13s	02/21/2023 12:00 AM	02/22/2023 10:30 AM
2302398-017	14s	02/21/2023 12:00 AM	02/22/2023 10:30 AM
2302398-018	15s	02/21/2023 12:00 AM	02/22/2023 10:30 AM
2302398-019	16s	02/21/2023 12:00 AM	02/22/2023 10:30 AM
2302398-020	16d	02/21/2023 12:00 AM	02/22/2023 10:30 AM
2302398-021	17s	02/21/2023 12:00 AM	02/22/2023 10:30 AM
2302398-022	18s	02/21/2023 12:00 AM	02/22/2023 10:30 AM
2302398-023	19s	02/21/2023 12:00 AM	02/22/2023 10:30 AM
2302398-024	20s	02/21/2023 12:00 AM	02/22/2023 10:30 AM
2302398-025	20d	02/21/2023 12:00 AM	02/22/2023 10:30 AM
2302398-026	21s	02/21/2023 12:00 AM	02/22/2023 10:30 AM
2302398-027	22s	02/21/2023 12:00 AM	02/22/2023 10:30 AM
2302398-028	23s	02/21/2023 12:00 AM	02/22/2023 10:30 AM

Note: If no "Time Collected" is supplied, a default of 12:00AM is assigned

CLIENT: Libby Environmental

Project: NSP - Gravel Pit

I. SAMPLE RECEIPT:

Samples receipt information is recorded on the attached Sample Receipt Checklist.

II. GENERAL REPORTING COMMENTS:

Results are reported on a wet weight basis unless dry-weight correction is denoted in the units field on the analytical report ("mg/kg-dry" or "ug/kg-dry").

Matrix Spike (MS) and MS Duplicate (MSD) samples are tested from an analytical batch of "like" matrix to check for possible matrix effect. The MS and MSD will provide site specific matrix data only for those samples which are spiked by the laboratory. The sample chosen for spike purposes may or may not have been a sample submitted in this sample delivery group. The validity of the analytical procedures for which data is reported in this analytical report is determined by the Laboratory Control Sample (LCS) and the Method Blank (MB). The LCS and the MB are processed with the samples and the MS/MSD to ensure method criteria are achieved throughout the entire analytical process.

III. ANALYSES AND EXCEPTIONS:

Exceptions associated with this report will be footnoted in the analytical results page(s) or the quality control summary page(s) and/or noted below.

Qualifiers:

- * - Flagged value is not within established control limits
- B - Analyte detected in the associated Method Blank
- D - Dilution was required
- E - Value above quantitation range
- H - Holding times for preparation or analysis exceeded
- I - Analyte with an internal standard that does not meet established acceptance criteria
- J - Analyte detected below Reporting Limit
- N - Tentatively Identified Compound (TIC)
- Q - Analyte with an initial or continuing calibration that does not meet established acceptance criteria
- S - Spike recovery outside accepted recovery limits
- ND - Not detected at the Reporting Limit
- R - High relative percent difference observed

Acronyms:

- %Rec - Percent Recovery
- CCB - Continued Calibration Blank
- CCV - Continued Calibration Verification
- DF - Dilution Factor
- DUP - Sample Duplicate
- HEM - Hexane Extractable Material
- ICV - Initial Calibration Verification
- LCS/LCSD - Laboratory Control Sample / Laboratory Control Sample Duplicate
- MCL - Maximum Contaminant Level
- MB or MBLANK - Method Blank
- MDL - Method Detection Limit
- MS/MSD - Matrix Spike / Matrix Spike Duplicate
- PDS - Post Digestion Spike
- Ref Val - Reference Value
- REP - Sample Replicate
- RL - Reporting Limit
- RPD - Relative Percent Difference
- SD - Serial Dilution
- SGT - Silica Gel Treatment
- SPK - Spike
- Surr - Surrogate



CLIENT: Libby Environmental

Project: NSP - Gravel Pit

Lab ID: 2302398-001

Collection Date: 2/21/2023

Client Sample ID: 1s

Matrix: Soil

Analyses	Result	RL	Qual	Units	DF	Date Analyzed
----------	--------	----	------	-------	----	---------------

Total Metals by EPA Method 6020B

Batch ID: 39546 Analyst: JR

Lead	34.5	0.932		mg/Kg-dry	1	2/27/2023 5:21:00 PM
------	------	-------	--	-----------	---	----------------------

Sample Moisture (Percent Moisture)

Batch ID: R82018 Analyst: ET

Percent Moisture	16.1	0.500		wt%	1	2/22/2023 12:15:03 PM
------------------	------	-------	--	-----	---	-----------------------

Lab ID: 2302398-002

Collection Date: 2/21/2023

Client Sample ID: 2s

Matrix: Soil

Analyses	Result	RL	Qual	Units	DF	Date Analyzed
----------	--------	----	------	-------	----	---------------

Total Metals by EPA Method 6020B

Batch ID: 39546 Analyst: JR

Lead	17.4	1.05		mg/Kg-dry	1	2/27/2023 5:28:00 PM
------	------	------	--	-----------	---	----------------------

Sample Moisture (Percent Moisture)

Batch ID: R82018 Analyst: ET

Percent Moisture	23.8	0.500		wt%	1	2/22/2023 12:15:03 PM
------------------	------	-------	--	-----	---	-----------------------

Lab ID: 2302398-003

Collection Date: 2/21/2023

Client Sample ID: 3s

Matrix: Soil

Analyses	Result	RL	Qual	Units	DF	Date Analyzed
----------	--------	----	------	-------	----	---------------

Total Metals by EPA Method 6020B

Batch ID: 39546 Analyst: JR

Lead	6.81	0.952		mg/Kg-dry	1	2/27/2023 5:30:00 PM
------	------	-------	--	-----------	---	----------------------

Sample Moisture (Percent Moisture)

Batch ID: R82018 Analyst: ET

Percent Moisture	17.9	0.500		wt%	1	2/22/2023 12:15:03 PM
------------------	------	-------	--	-----	---	-----------------------



CLIENT: Libby Environmental

Project: NSP - Gravel Pit

Lab ID: 2302398-004

Collection Date: 2/21/2023

Client Sample ID: 4s

Matrix: Soil

Analyses	Result	RL	Qual	Units	DF	Date Analyzed
----------	--------	----	------	-------	----	---------------

Total Metals by EPA Method 6020B

Batch ID: 39546 Analyst: JR

Lead	10.9	1.01		mg/Kg-dry	1	2/27/2023 5:32:00 PM
------	------	------	--	-----------	---	----------------------

Sample Moisture (Percent Moisture)

Batch ID: R82018 Analyst: ET

Percent Moisture	22.9	0.500		wt%	1	2/22/2023 12:15:03 PM
------------------	------	-------	--	-----	---	-----------------------

Lab ID: 2302398-005

Collection Date: 2/21/2023

Client Sample ID: 4d

Matrix: Soil

Analyses	Result	RL	Qual	Units	DF	Date Analyzed
----------	--------	----	------	-------	----	---------------

Total Metals by EPA Method 6020B

Batch ID: 39546 Analyst: JR

Lead	8.13	0.962		mg/Kg-dry	1	2/27/2023 5:35:00 PM
------	------	-------	--	-----------	---	----------------------

Sample Moisture (Percent Moisture)

Batch ID: R82018 Analyst: ET

Percent Moisture	18.8	0.500		wt%	1	2/22/2023 12:15:03 PM
------------------	------	-------	--	-----	---	-----------------------

Lab ID: 2302398-006

Collection Date: 2/21/2023

Client Sample ID: 5s

Matrix: Soil

Analyses	Result	RL	Qual	Units	DF	Date Analyzed
----------	--------	----	------	-------	----	---------------

Total Metals by EPA Method 6020B

Batch ID: 39546 Analyst: JR

Lead	6.25	0.927		mg/Kg-dry	1	2/27/2023 5:37:00 PM
------	------	-------	--	-----------	---	----------------------

Sample Moisture (Percent Moisture)

Batch ID: R82018 Analyst: ET

Percent Moisture	14.4	0.500		wt%	1	2/22/2023 12:15:03 PM
------------------	------	-------	--	-----	---	-----------------------



CLIENT: Libby Environmental

Project: NSP - Gravel Pit

Lab ID: 2302398-007

Collection Date: 2/21/2023

Client Sample ID: 6s

Matrix: Soil

Analyses	Result	RL	Qual	Units	DF	Date Analyzed
----------	--------	----	------	-------	----	---------------

Total Metals by EPA Method 6020B

Batch ID: 39546 Analyst: JR

Lead	47.4	0.942		mg/Kg-dry	1	2/27/2023 5:39:00 PM
------	------	-------	--	-----------	---	----------------------

Sample Moisture (Percent Moisture)

Batch ID: R82018 Analyst: ET

Percent Moisture	17.1	0.500		wt%	1	2/22/2023 12:15:03 PM
------------------	------	-------	--	-----	---	-----------------------

Lab ID: 2302398-008

Collection Date: 2/21/2023

Client Sample ID: 7s

Matrix: Soil

Analyses	Result	RL	Qual	Units	DF	Date Analyzed
----------	--------	----	------	-------	----	---------------

Total Metals by EPA Method 6020B

Batch ID: 39546 Analyst: JR

Lead	49.2	0.868		mg/Kg-dry	1	2/27/2023 5:42:00 PM
------	------	-------	--	-----------	---	----------------------

Sample Moisture (Percent Moisture)

Batch ID: R82018 Analyst: ET

Percent Moisture	10.7	0.500		wt%	1	2/22/2023 12:15:03 PM
------------------	------	-------	--	-----	---	-----------------------

Lab ID: 2302398-009

Collection Date: 2/21/2023

Client Sample ID: 8s

Matrix: Soil

Analyses	Result	RL	Qual	Units	DF	Date Analyzed
----------	--------	----	------	-------	----	---------------

Total Metals by EPA Method 6020B

Batch ID: 39546 Analyst: JR

Lead	266	2.66	D	mg/Kg-dry	10	3/3/2023 2:34:00 PM
------	-----	------	---	-----------	----	---------------------

Sample Moisture (Percent Moisture)

Batch ID: R82018 Analyst: ET

Percent Moisture	9.94	0.500		wt%	1	2/22/2023 12:15:03 PM
------------------	------	-------	--	-----	---	-----------------------



CLIENT: Libby Environmental

Project: NSP - Gravel Pit

Lab ID: 2302398-010

Collection Date: 2/21/2023

Client Sample ID: 8d

Matrix: Soil

Analyses	Result	RL	Qual	Units	DF	Date Analyzed
----------	--------	----	------	-------	----	---------------

Total Metals by EPA Method 6020B

Batch ID: 39546 Analyst: JR

Lead	258	8.76	D	mg/Kg-dry	10	3/3/2023 2:37:00 PM
------	-----	------	---	-----------	----	---------------------

Sample Moisture (Percent Moisture)

Batch ID: R82018 Analyst: ET

Percent Moisture	8.64	0.500		wt%	1	2/22/2023 12:15:03 PM
------------------	------	-------	--	-----	---	-----------------------

Lab ID: 2302398-012

Collection Date: 2/21/2023

Client Sample ID: 10s

Matrix: Soil

Analyses	Result	RL	Qual	Units	DF	Date Analyzed
----------	--------	----	------	-------	----	---------------

Total Metals by EPA Method 6020B

Batch ID: 39565 Analyst: JR

Lead	17.4	0.922		mg/Kg-dry	1	2/28/2023 12:24:00 PM
------	------	-------	--	-----------	---	-----------------------

Sample Moisture (Percent Moisture)

Batch ID: R82018 Analyst: ET

Percent Moisture	13.9	0.500		wt%	1	2/22/2023 12:15:03 PM
------------------	------	-------	--	-----	---	-----------------------

Lab ID: 2302398-013

Collection Date: 2/21/2023

Client Sample ID: 11s

Matrix: Soil

Analyses	Result	RL	Qual	Units	DF	Date Analyzed
----------	--------	----	------	-------	----	---------------

Total Metals by EPA Method 6020B

Batch ID: 39565 Analyst: JR

Lead	16.5	0.845		mg/Kg-dry	1	2/28/2023 12:39:00 PM
------	------	-------	--	-----------	---	-----------------------

Sample Moisture (Percent Moisture)

Batch ID: R82018 Analyst: ET

Percent Moisture	10.4	0.500		wt%	1	2/22/2023 12:15:03 PM
------------------	------	-------	--	-----	---	-----------------------



CLIENT: Libby Environmental

Project: NSP - Gravel Pit

Lab ID: 2302398-014

Collection Date: 2/21/2023

Client Sample ID: 12s

Matrix: Soil

Analyses	Result	RL	Qual	Units	DF	Date Analyzed
<u>Total Metals by EPA Method 6020B</u>				Batch ID: 39565		Analyst: JR
Lead	36.0	0.840		mg/Kg-dry	1	2/28/2023 12:41:00 PM
<u>Sample Moisture (Percent Moisture)</u>				Batch ID: R82018		Analyst: ET
Percent Moisture	7.68	0.500		wt%	1	2/22/2023 12:15:03 PM

Lab ID: 2302398-015

Collection Date: 2/21/2023

Client Sample ID: 12d

Matrix: Soil

Analyses	Result	RL	Qual	Units	DF	Date Analyzed
<u>Total Metals by EPA Method 6020B</u>				Batch ID: 39565		Analyst: JR
Lead	45.4	0.797		mg/Kg-dry	1	2/28/2023 12:43:00 PM
<u>Sample Moisture (Percent Moisture)</u>				Batch ID: R82018		Analyst: ET
Percent Moisture	7.69	0.500		wt%	1	2/22/2023 12:15:03 PM

Lab ID: 2302398-016

Collection Date: 2/21/2023

Client Sample ID: 13s

Matrix: Soil

Analyses	Result	RL	Qual	Units	DF	Date Analyzed
<u>Total Metals by EPA Method 6020B</u>				Batch ID: 39565		Analyst: JR
Lead	190	8.73	D	mg/Kg-dry	10	3/1/2023 11:23:00 AM
<u>Sample Moisture (Percent Moisture)</u>				Batch ID: R82018		Analyst: ET
Percent Moisture	9.85	0.500		wt%	1	2/22/2023 12:15:03 PM



CLIENT: Libby Environmental

Project: NSP - Gravel Pit

Lab ID: 2302398-017

Collection Date: 2/21/2023

Client Sample ID: 14s

Matrix: Soil

Analyses	Result	RL	Qual	Units	DF	Date Analyzed
----------	--------	----	------	-------	----	---------------

Total Metals by EPA Method 6020B

Batch ID: 39565 Analyst: JR

Lead	173	9.30	D	mg/Kg-dry	10	3/1/2023 11:26:00 AM
------	-----	------	---	-----------	----	----------------------

Sample Moisture (Percent Moisture)

Batch ID: R82018 Analyst: ET

Percent Moisture	14.0	0.500		wt%	1	2/22/2023 12:15:03 PM
------------------	------	-------	--	-----	---	-----------------------

Lab ID: 2302398-018

Collection Date: 2/21/2023

Client Sample ID: 15s

Matrix: Soil

Analyses	Result	RL	Qual	Units	DF	Date Analyzed
----------	--------	----	------	-------	----	---------------

Total Metals by EPA Method 6020B

Batch ID: 39565 Analyst: JR

Lead	192	8.30	D	mg/Kg-dry	10	3/1/2023 11:28:00 AM
------	-----	------	---	-----------	----	----------------------

Sample Moisture (Percent Moisture)

Batch ID: R82022 Analyst: ET

Percent Moisture	10.8	0.500		wt%	1	2/22/2023 1:09:56 PM
------------------	------	-------	--	-----	---	----------------------

Lab ID: 2302398-019

Collection Date: 2/21/2023

Client Sample ID: 16s

Matrix: Soil

Analyses	Result	RL	Qual	Units	DF	Date Analyzed
----------	--------	----	------	-------	----	---------------

Total Metals by EPA Method 6020B

Batch ID: 39565 Analyst: JR

Lead	185	9.25	D	mg/Kg-dry	10	3/1/2023 11:30:00 AM
------	-----	------	---	-----------	----	----------------------

Sample Moisture (Percent Moisture)

Batch ID: R82022 Analyst: ET

Percent Moisture	14.9	0.500		wt%	1	2/22/2023 1:09:56 PM
------------------	------	-------	--	-----	---	----------------------



CLIENT: Libby Environmental

Project: NSP - Gravel Pit

Lab ID: 2302398-020

Collection Date: 2/21/2023

Client Sample ID: 16d

Matrix: Soil

Analyses	Result	RL	Qual	Units	DF	Date Analyzed
<u>Total Metals by EPA Method 6020B</u>				Batch ID: 39565		Analyst: JR
Lead	61.0	0.863		mg/Kg-dry	1	2/28/2023 12:58:00 PM
<u>Sample Moisture (Percent Moisture)</u>				Batch ID: R82022		Analyst: ET
Percent Moisture	8.75	0.500		wt%	1	2/22/2023 1:09:56 PM

Lab ID: 2302398-021

Collection Date: 2/21/2023

Client Sample ID: 17s

Matrix: Soil

Analyses	Result	RL	Qual	Units	DF	Date Analyzed
<u>Total Metals by EPA Method 6020B</u>				Batch ID: 39565		Analyst: JR
Lead	81.8	1.03		mg/Kg-dry	1	2/28/2023 1:00:00 PM
<u>Sample Moisture (Percent Moisture)</u>				Batch ID: R82022		Analyst: ET
Percent Moisture	27.3	0.500		wt%	1	2/22/2023 1:09:56 PM

Lab ID: 2302398-023

Collection Date: 2/21/2023

Client Sample ID: 19s

Matrix: Soil

Analyses	Result	RL	Qual	Units	DF	Date Analyzed
<u>Total Metals by EPA Method 6020B</u>				Batch ID: 39565		Analyst: JR
Lead	18.2	0.880		mg/Kg-dry	1	2/28/2023 1:02:00 PM
<u>Sample Moisture (Percent Moisture)</u>				Batch ID: R82022		Analyst: ET
Percent Moisture	10.6	0.500		wt%	1	2/22/2023 1:09:56 PM



CLIENT: Libby Environmental

Project: NSP - Gravel Pit

Lab ID: 2302398-024

Collection Date: 2/21/2023

Client Sample ID: 20s

Matrix: Soil

Analyses	Result	RL	Qual	Units	DF	Date Analyzed
----------	--------	----	------	-------	----	---------------

Total Metals by EPA Method 6020B

Batch ID: 39565 Analyst: JR

Lead	591	8.58	D	mg/Kg-dry	10	3/1/2023 11:33:00 AM
------	-----	------	---	-----------	----	----------------------

Sample Moisture (Percent Moisture)

Batch ID: R82022 Analyst: ET

Percent Moisture	11.7	0.500		wt%	1	2/22/2023 1:09:56 PM
------------------	------	-------	--	-----	---	----------------------

Lab ID: 2302398-025

Collection Date: 2/21/2023

Client Sample ID: 20d

Matrix: Soil

Analyses	Result	RL	Qual	Units	DF	Date Analyzed
----------	--------	----	------	-------	----	---------------

Total Metals by EPA Method 6020B

Batch ID: 39565 Analyst: JR

Lead	203	8.81	D	mg/Kg-dry	10	3/1/2023 11:35:00 AM
------	-----	------	---	-----------	----	----------------------

Sample Moisture (Percent Moisture)

Batch ID: R82022 Analyst: ET

Percent Moisture	12.0	0.500		wt%	1	2/22/2023 1:09:56 PM
------------------	------	-------	--	-----	---	----------------------

Lab ID: 2302398-026

Collection Date: 2/21/2023

Client Sample ID: 21s

Matrix: Soil

Analyses	Result	RL	Qual	Units	DF	Date Analyzed
----------	--------	----	------	-------	----	---------------

Total Metals by EPA Method 6020B

Batch ID: 39565 Analyst: JR

Lead	25.5	1.16		mg/Kg-dry	1	2/28/2023 1:09:00 PM
------	------	------	--	-----------	---	----------------------

Sample Moisture (Percent Moisture)

Batch ID: R82022 Analyst: ET

Percent Moisture	32.3	0.500		wt%	1	2/22/2023 1:09:56 PM
------------------	------	-------	--	-----	---	----------------------



CLIENT: Libby Environmental

Project: NSP - Gravel Pit

Lab ID: 2302398-027

Collection Date: 2/21/2023

Client Sample ID: 22s

Matrix: Soil

Analyses	Result	RL	Qual	Units	DF	Date Analyzed
----------	--------	----	------	-------	----	---------------

Total Metals by EPA Method 6020B

Batch ID: 39565 Analyst: JR

Lead	26.5	0.920		mg/Kg-dry	1	2/28/2023 1:11:00 PM
------	------	-------	--	-----------	---	----------------------

Sample Moisture (Percent Moisture)

Batch ID: R82022 Analyst: ET

Percent Moisture	16.4	0.500		wt%	1	2/22/2023 1:09:56 PM
------------------	------	-------	--	-----	---	----------------------

Lab ID: 2302398-028

Collection Date: 2/21/2023

Client Sample ID: 23s

Matrix: Soil

Analyses	Result	RL	Qual	Units	DF	Date Analyzed
----------	--------	----	------	-------	----	---------------

Total Metals by EPA Method 6020B

Batch ID: 39565 Analyst: JR

Lead	235	8.40	D	mg/Kg-dry	10	3/1/2023 11:37:00 AM
------	-----	------	---	-----------	----	----------------------

Sample Moisture (Percent Moisture)

Batch ID: R82022 Analyst: ET

Percent Moisture	11.8	0.500		wt%	1	2/22/2023 1:09:56 PM
------------------	------	-------	--	-----	---	----------------------

Work Order: 2302398
 CLIENT: Libby Environmental
 Project: NSP - Gravel Pit

QC SUMMARY REPORT
Total Metals by EPA Method 6020B

Sample ID: MB-39546	SampType: MBLK	Units: mg/Kg	Prep Date: 2/27/2023	RunNo: 82118							
Client ID: MBLKS	Batch ID: 39546	Analysis Date: 2/27/2023	SeqNo: 1704828								
Analyte	Result	RL	SPK value	SPK Ref Val	%REC	LowLimit	HighLimit	RPD Ref Val	%RPD	RPDLimit	Qual

Lead ND 1.00

Sample ID: LCS-39546	SampType: LCS	Units: mg/Kg	Prep Date: 2/27/2023	RunNo: 82118							
Client ID: LCSS	Batch ID: 39546	Analysis Date: 2/27/2023	SeqNo: 1704829								
Analyte	Result	RL	SPK value	SPK Ref Val	%REC	LowLimit	HighLimit	RPD Ref Val	%RPD	RPDLimit	Qual

Lead 19.0 0.800 20.00 0 95.0 80 120

Sample ID: 2302441-001AMS	SampType: MS	Units: mg/Kg-dry	Prep Date: 2/27/2023	RunNo: 82118							
Client ID: BATCH	Batch ID: 39546	Analysis Date: 2/27/2023	SeqNo: 1704832								
Analyte	Result	RL	SPK value	SPK Ref Val	%REC	LowLimit	HighLimit	RPD Ref Val	%RPD	RPDLimit	Qual

Lead 94.3 3.65 91.14 9.634 92.9 75 125

Sample ID: 2302441-001AMSD	SampType: MSD	Units: mg/Kg-dry	Prep Date: 2/27/2023	RunNo: 82118							
Client ID: BATCH	Batch ID: 39546	Analysis Date: 2/27/2023	SeqNo: 1704833								
Analyte	Result	RL	SPK value	SPK Ref Val	%REC	LowLimit	HighLimit	RPD Ref Val	%RPD	RPDLimit	Qual

Lead 93.5 3.59 89.78 9.634 93.4 75 125 94.28 0.791 20

Sample ID: MB-39565	SampType: MBLK	Units: mg/Kg	Prep Date: 2/28/2023	RunNo: 82137							
Client ID: MBLKS	Batch ID: 39565	Analysis Date: 2/28/2023	SeqNo: 1705419								
Analyte	Result	RL	SPK value	SPK Ref Val	%REC	LowLimit	HighLimit	RPD Ref Val	%RPD	RPDLimit	Qual

Lead ND 1.00

Work Order: 2302398
CLIENT: Libby Environmental
Project: NSP - Gravel Pit

QC SUMMARY REPORT
Total Metals by EPA Method 6020B

Sample ID: LCS-39565		SampType: LCS		Units: mg/Kg		Prep Date: 2/28/2023		RunNo: 82137			
Client ID: LCSS		Batch ID: 39565				Analysis Date: 2/28/2023		SeqNo: 1705420			
Analyte	Result	RL	SPK value	SPK Ref Val	%REC	LowLimit	HighLimit	RPD Ref Val	%RPD	RPDLimit	Qual
Lead	21.1	0.781	19.53	0	108	80	120				

Sample ID: 2302398-012AMS		SampType: MS		Units: mg/Kg-dry		Prep Date: 2/28/2023		RunNo: 82137			
Client ID: 10s		Batch ID: 39565				Analysis Date: 2/28/2023		SeqNo: 1705425			
Analyte	Result	RL	SPK value	SPK Ref Val	%REC	LowLimit	HighLimit	RPD Ref Val	%RPD	RPDLimit	Qual
Lead	36.6	0.867	21.67	17.40	88.6	75	125				

Sample ID: 2302398-012AMSD		SampType: MSD		Units: mg/Kg-dry		Prep Date: 2/28/2023		RunNo: 82137			
Client ID: 10s		Batch ID: 39565				Analysis Date: 2/28/2023		SeqNo: 1705426			
Analyte	Result	RL	SPK value	SPK Ref Val	%REC	LowLimit	HighLimit	RPD Ref Val	%RPD	RPDLimit	Qual
Lead	40.1	0.914	22.86	17.40	99.5	75	125	36.59	9.25	20	

Client Name: **LIBBY**
 Logged by: **Clare Griggs**

Work Order Number: **2302398**
 Date Received: **2/22/2023 10:30:00 AM**

Chain of Custody

1. Is Chain of Custody complete? Yes No Not Present
 2. How was the sample delivered? UPS

Log In

3. Coolers are present? Yes No NA
 4. Shipping container/cooler in good condition? Yes No
 5. Custody Seals present on shipping container/cooler?
 (Refer to comments for Custody Seals not intact) Yes No Not Present
 6. Was an attempt made to cool the samples? Yes No NA
 7. Were all items received at a temperature of >2°C to 6°C * Yes No NA
 8. Sample(s) in proper container(s)? Yes No
 9. Sufficient sample volume for indicated test(s)? Yes No
 10. Are samples properly preserved? Yes No
 11. Was preservative added to bottles? Yes No NA
 12. Is there headspace in the VOA vials? Yes No NA
 13. Did all samples containers arrive in good condition(unbroken)? Yes No
 14. Does paperwork match bottle labels? Yes No
 15. Are matrices correctly identified on Chain of Custody? Yes No
 16. Is it clear what analyses were requested? Yes No
 17. Were all holding times able to be met? Yes No

Special Handling (if applicable)

18. Was client notified of all discrepancies with this order? Yes No NA

Person Notified:	<input type="text" value="Emily Bushlen"/>	Date:	<input type="text" value="2/23/2023"/>
By Whom:	<input type="text" value="Brianna Barnes"/>	Via:	<input checked="" type="checkbox"/> eMail <input type="checkbox"/> Phone <input type="checkbox"/> Fax <input type="checkbox"/> In Person
Regarding:	<input type="text" value="Volume was spilled for 9s and 18s before analysis was started."/>		
Client Instructions:	<input type="text" value="Proceed with other samples."/>		

19. Additional remarks:

Item Information

Item #	Temp °C
Sample	2.1

* Note: DoD/ELAP and TNI require items to be received at 4°C +/- 2°C



Libby Environmental, Inc.

3322 South Bay Road NE • Olympia, WA 98506-2957

**SUBCONTRACT
ORDER
L23B086**

Sending Laboratory:

Libby Environmental, Inc.
3322 South Bay Road NE
Olympia, WA 98506
Phone: 360-352-2110
Fax: 360-352-4154

Project Manager: Sherry Chilcutt
LibbyEnv@gmail.com

Subcontracted Laboratory:

2302398

Fremont Analytical, Inc.
3600 Fremont Ave N
Seattle, WA 98103
Phone: (206) 352-3790
Fax:

Requested Turnaround (TAT) STD

Project: NSP - Gravel Pit

Analysis	Comments
Client Sample ID: 1s Soil Sampled: 02/21/2023 00:00 Metals SUB Pb Containers Supplied:	6000 Series Lab ID: L23B086-01
Client Sample ID: 2s Soil Sampled: 02/21/2023 00:00 Metals SUB Pb Containers Supplied:	6000 Series Lab ID: L23B086-02
Client Sample ID: 3s Soil Sampled: 02/21/2023 00:00 Metals SUB Pb Containers Supplied:	6000 Series Lab ID: L23B086-03
Client Sample ID: 4s Soil Sampled: 02/21/2023 00:00 Metals SUB Pb Containers Supplied:	6000 Series Lab ID: L23B086-04
Client Sample ID: 4d Soil Sampled: 02/21/2023 00:00 Metals SUB Pb Containers Supplied:	6000 Series Lab ID: L23B086-05
Client Sample ID: 5s Soil Sampled: 02/21/2023 00:00 Metals SUB Pb Containers Supplied:	6000 Series Lab ID: L23B086-06

Released By Sherry Chilcutt Date 2.21.23
Sherry Chilcutt 2.21.23

Received By Alex Miller Date 2/22/23 10:30
Date
Page 17 of 20



Libby Environmental, Inc.

3322 South Bay Road NE • Olympia, WA 98506-2957

**SUBCONTRACT
ORDER
L23B086
(Continued)**

2302398

Project: NSP - Gravel Pit

Analysis	Comments
Client Sample ID: 6s Soil Sampled: 02/21/2023 00:00 Metals SUB Pb Containers Supplied:	6000 Series Lab ID: L23B086-07
Client Sample ID: 7s Soil Sampled: 02/21/2023 00:00 Metals SUB Pb Containers Supplied:	6000 Series Lab ID: L23B086-08
Client Sample ID: 8s Soil Sampled: 02/21/2023 00:00 Metals SUB Pb Containers Supplied:	6000 Series Lab ID: L23B086-09
Client Sample ID: 8d Soil Sampled: 02/21/2023 00:00 Metals SUB Pb Containers Supplied:	6000 Series Lab ID: L23B086-10
Client Sample ID: 9s Soil Sampled: 02/21/2023 00:00 Metals SUB Pb Containers Supplied:	6000 Series Lab ID: L23B086-11
Client Sample ID: 10s Soil Sampled: 02/21/2023 00:00 Metals SUB Pb Containers Supplied:	6000 Series Lab ID: L23B086-12
Client Sample ID: 11s Soil Sampled: 02/21/2023 00:00 Metals SUB Pb Containers Supplied:	6000 Series Lab ID: L23B086-13
Client Sample ID: 12s Soil Sampled: 02/21/2023 00:00 Metals SUB Pb Containers Supplied:	6000 Series Lab ID: L23B086-14

Released By

2.21.23
Date

Received By

2/22/23 10:30
Date



Libby Environmental, Inc.

3322 South Bay Road NE • Olympia, WA 98506-2957

**SUBCONTRACT
ORDER
L23B086
(Continued)**

2302398

Project: NSP - Gravel Pit

Analysis	Comments
Client Sample ID: 12d Soil Sampled: 02/21/2023 00:00	Lab ID: L23B086-15
Metals SUB Pb Containers Supplied:	6000 Series
Client Sample ID: 13s Soil Sampled: 02/21/2023 00:00	Lab ID: L23B086-16
Metals SUB Pb Containers Supplied:	6000 Series
Client Sample ID: 14s Soil Sampled: 02/21/2023 00:00	Lab ID: L23B086-17
Metals SUB Pb Containers Supplied:	6000 Series
Client Sample ID: 15s Soil Sampled: 02/21/2023 00:00	Lab ID: L23B086-18
Metals SUB Pb Containers Supplied:	6000 Series
Client Sample ID: 16s Soil Sampled: 02/21/2023 00:00	Lab ID: L23B086-19
Metals SUB Pb Containers Supplied:	6000 Series
Client Sample ID: 16d Soil Sampled: 02/21/2023 00:00	Lab ID: L23B086-20
Metals SUB Pb Containers Supplied:	6000 Series
Client Sample ID: 17s Soil Sampled: 02/21/2023 00:00	Lab ID: L23B086-21
Metals SUB Pb Containers Supplied:	6000 Series
Client Sample ID: 18s Soil Sampled: 02/21/2023 00:00	Lab ID: L23B086-22
Metals SUB Pb Containers Supplied:	6000 Series

Released By

Date 2-21-23

Received By

Date 2/22/23 10:30

Page 19 of 20



Libby Environmental, Inc.

3322 South Bay Road NE • Olympia, WA 98506-2957

**SUBCONTRACT
ORDER
L23B086
(Continued)**

Project: NSP - Gravel Pit

2302398

Analysis	Comments
Client Sample ID: 19s <i>Soil Sampled: 02/21/2023 00:00</i> Metals SUB Pb <i>Containers Supplied:</i>	Lab ID: L23B086-23 6000 Series
Client Sample ID: 20s <i>Soil Sampled: 02/21/2023 00:00</i> Metals SUB Pb <i>Containers Supplied:</i>	Lab ID: L23B086-24 6000 Series
Client Sample ID: 20d <i>Soil Sampled: 02/21/2023 00:00</i> Metals SUB Pb <i>Containers Supplied:</i>	Lab ID: L23B086-25 6000 Series
Client Sample ID: 21s <i>Soil Sampled: 02/21/2023 00:00</i> Metals SUB Pb <i>Containers Supplied:</i>	Lab ID: L23B086-26 6000 Series
Client Sample ID: 22s <i>Soil Sampled: 02/21/2023 00:00</i> Metals SUB Pb <i>Containers Supplied:</i>	Lab ID: L23B086-27 6000 Series
Client Sample ID: 23s <i>Soil Sampled: 02/21/2023 00:00</i> Metals SUB Pb <i>Containers Supplied:</i>	Lab ID: L23B086-28 6000 Series

Released By

2-21-23
Date

Received By

2/22/23 10:30
Date



APPENDIX B
OTHER SUPPORTING DOCUMENTATION

FIGURE 9-2
Soil Analytical Results - ISM
(2021)
 Remedial Investigation
 Former Eatonville Landfill
 Eatonville, WA

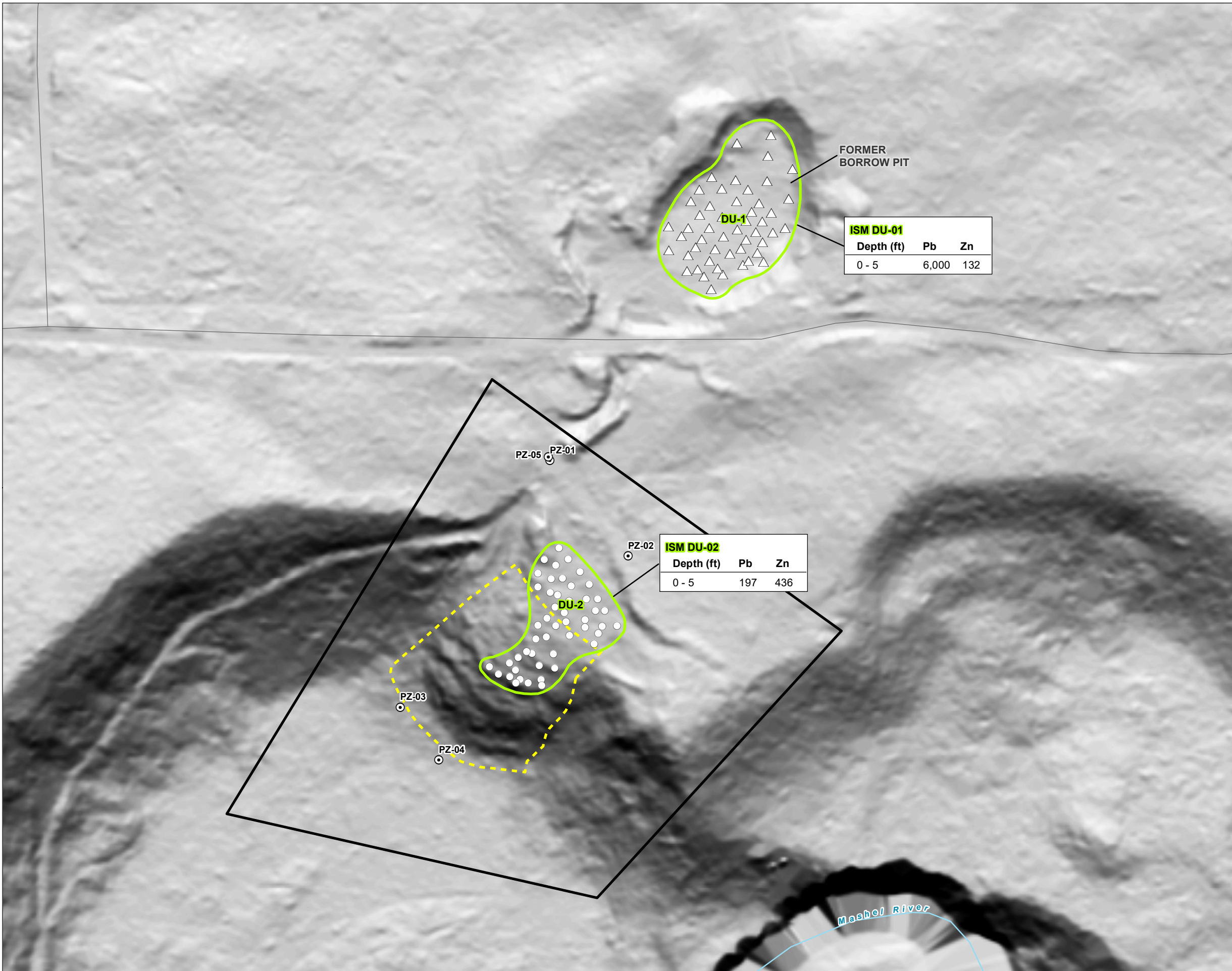

FORMER BORROW PIT

ISM DU-01

Depth (ft)	Pb	Zn
0 - 5	6,000	132

ISM DU-02

Depth (ft)	Pb	Zn
0 - 5	197	436

LEGEND

- Property Boundary
- Location of Former Landfill
- ISM Decision Unit Boundary
- Groundwater Monitoring Well
- ISM Sample Locations**
- ISM DU-1 (Borrow Pit)
- ISM DU-2 (Historic Landfill Cover)
- All Other Features**
- Road
- Watercourse

NOTES

1. Site features are approximate.
2. Results are shown in milligrams per kilogram.

Pb: Lead
 Zn: Zinc

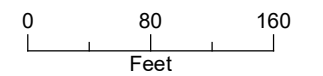
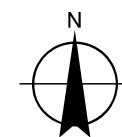

Date: February 8, 2022
 Data Sources: USGS, ESRI, DNR (2011),
 Pierce Co.



**NISQUALLY STATE PARK
NEW FULL SERVICE PARK – PHASE 2**

SECTION 010000 – GENERAL REQUIREMENTS

PART 1 - GENERAL

1.1 SPECIAL NOTICE

- A. Project work included in this bid will overlap and occur simultaneously with separately bid, adjacent, projects onsite. The Contractor shall schedule work to accommodate others' work onsite.

1.2 DESCRIPTION OF WORK

- A. This project includes a new Administration Building, new Staff Residence, and Roadway Improvements to the Nisqually River and Ohop Creek. Work includes, but is not limited to, site preparation, erosion control, excavation, utility improvements, construction of buildings and structures, aggregates, cast-in-place concrete, asphalt paving, catch basins and subsurface drainage, topsoil, restoration plantings and miscellaneous site improvements.

1.3 TIME FOR COMPLETION OF PROJECT

- A. Substantially complete project in accordance with the drawings and specifications within 365 calendar days from date on Notice to Proceed letter. Final completion in accordance with Contract Documents within 30 calendar days from substantial completion date.

1.4 HOURS OF WORK

- A. Work hours are between 7:00 a.m. and 7:00 p.m. Monday through Friday, excluding national holidays.

1.5 LIQUIDATED DAMAGES

- A. If Contractor fails to complete Contract within stipulated time, an assessment of \$500 per day will be made against Contractor for each additional day required to complete contract, unless an extension of time was granted through Change Order. This assessment is to cover Commission's liquidated damages and is not to be construed as a penalty.
- B. Contract authorizes the Washington State Parks and Recreation Commission to deduct liquidated damages from money due at completion of contract.

1.6 PRE-CONSTRUCTION CONFERENCE

- A. Following notification of award to Contractor, the date for an on-site pre-construction conference will be set. Do not commence Work prior to conference or until written clearance has been obtained from Project Representative.

**NISQUALLY STATE PARK
NEW FULL SERVICE PARK – PHASE 2**

- B. Furnish Project Representative with following:
1. Complete list of sub-contractors, including business address, telephone numbers, items of Work, and registration numbers. List is to be updated during contract life.
 2. Name and contact information of Contractor's staff who is in charge and responsible for site safety and will be on site at all times.
 3. A Site-Specific Safety Plan that is in compliance with the Department of Labor and Industries and 000011 – General Conditions specifically for this project.
 4. A progress schedule in accordance with General Conditions.
 5. A detailed cost breakdown for lump sum bid items. Furnish a fair evaluation of actual cost of each items of Work listed. This will be used in processing Contractor's requests for partial payment. Submittal of breakdown does not affect the Contract terms.
 6. Written document detailing plans to comply with 15 percent Apprenticeship Participation requirement stated in Instruction to Bidders 4.1B.
- C. Project Representative will supply a list of hazardous products that could be encountered on Project. Appropriate Safety Data Sheet (SDS) will be on file at park.

1.7 PROGRESS CLEANING

- A. Remove rubbish and debris from park property daily unless otherwise directed do not allow accumulation. Store materials that cannot be removed daily only in areas specified by the Project Representative.
- B. Maintain worksites in a neat and orderly condition.
- C. Cleanup operations are incidental to the Contract and no extra compensation will be made.

1.8 WASHINGTON STATE DEPARTMENT OF TRANSPORTATION (WSDOT)

- A. **None** of WSDOT General Requirements, measurement or payment provisions apply.

1.9 AS-BUILT DRAWINGS

- A. Keep a clean set of full-sized drawings at job site to use to identify changes.

1.10 PROJECT CONDITIONS

- A. Hazardous Materials: It is not expected that hazardous materials will be encountered in the Work.
 1. If materials suspected of containing hazardous materials are encountered, do not disturb; immediately notify Project Representative and Owner. Owner will remove hazardous materials under a separate contract.

**NISQUALLY STATE PARK
NEW FULL SERVICE PARK – PHASE 2**

1.11 PROJECT SIGN

- A. Provide following temporary sign. Sign location is shown on drawings or determined by Project Representative. Upon Project completion, remove sign and restore area to original condition.

1.12 PROJECT SIGN LETTERING

TITLE OF PROJECT:	NEW FULL SERVICE PARK – PHASE 2
NAME OF FACILITY:	NISQUALLY STATE PARK
NAME OF CONTRACTOR:	(Place Contractor's Name here)
ADDRESS OF CONTRACTOR:	(Place Contractor's Address here)
FUNDING TITLE NUMBER 1:	STATE BUILDING CONSTRUCTION ACCOUNT

1.13 PARTNERSHIP IN THE CONTRACT

- A. As partners in this contract, both Contractor and Commission recognize the value of a successful Project. Both parties recognize, besides the tangible benefits to Contractor and the Commission, the citizens of Washington State and visitors to Washington State Parks will benefit immensely from the successful completion of a quality Project.

PART 2 - PRODUCTS (NOT USED)

PART 3 - EXECUTION (NOT USED)

**NISQUALLY STATE PARK
NEW FULL SERVICE PARK – PHASE 2**

PROJECT SIGN DETAIL

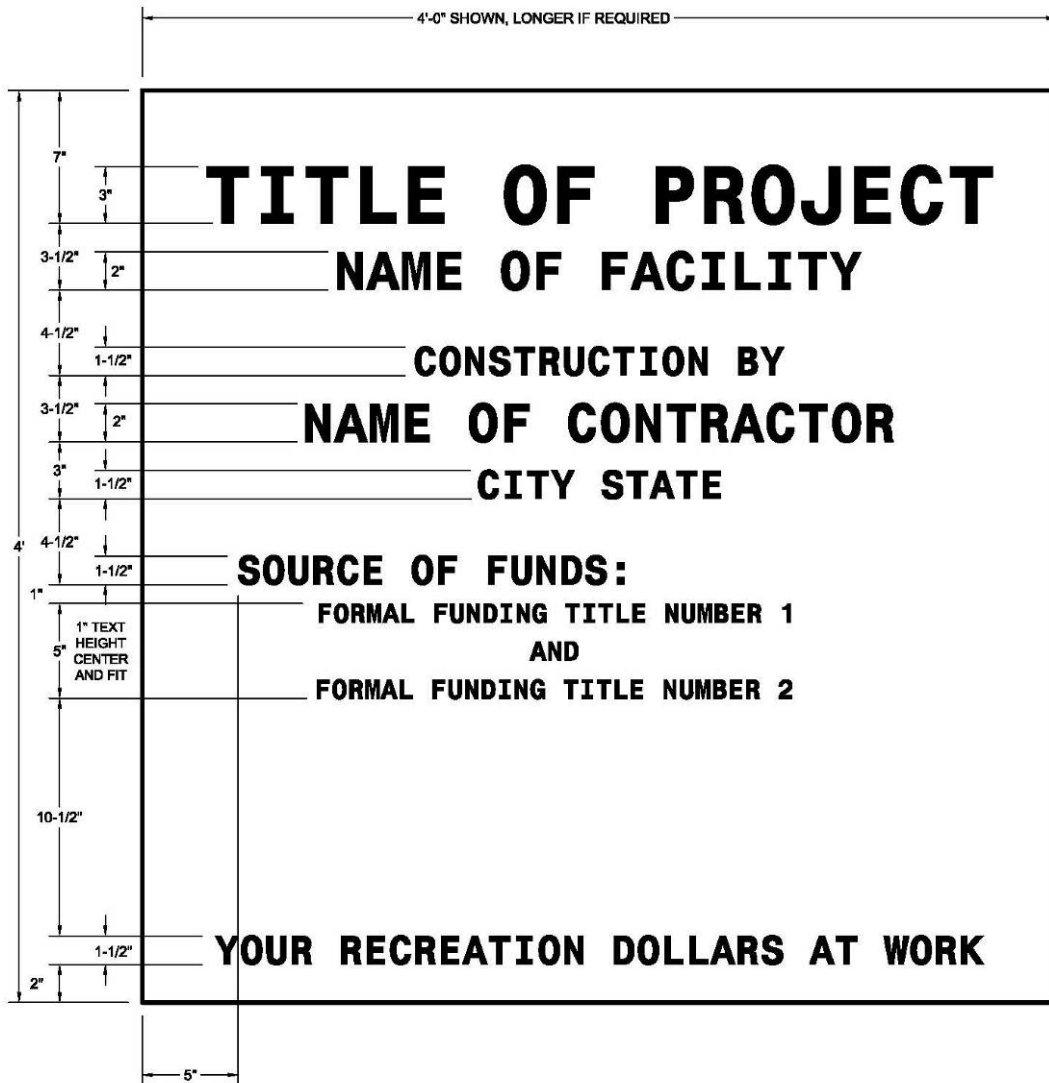

LAY OUT SIGN TO FIT ON A PORTION OF ONE (1) SHEET OF PLYWOOD. IF PLYWOOD IS THE FINAL SURFACE, PAINT IT WITH TWO (2) OR MORE COATS OF WHITE PAINT TO FORM A SMOOTH, NONABSORBENT SURFACE. PROVIDE DARK GREEN WELL FORMED LETTERS, EVENLY SPACED, NEAT IN APPEARANCE, AND ALIGNED AS SHOWN ABOVE.

**WASHINGTON STATE PARKS
PROJECT SIGN DETAIL**

NISQUALLY STATE PARK
NEW FULL SERVICE PARK - PHASE 2

PROJECT SIGN DETAIL

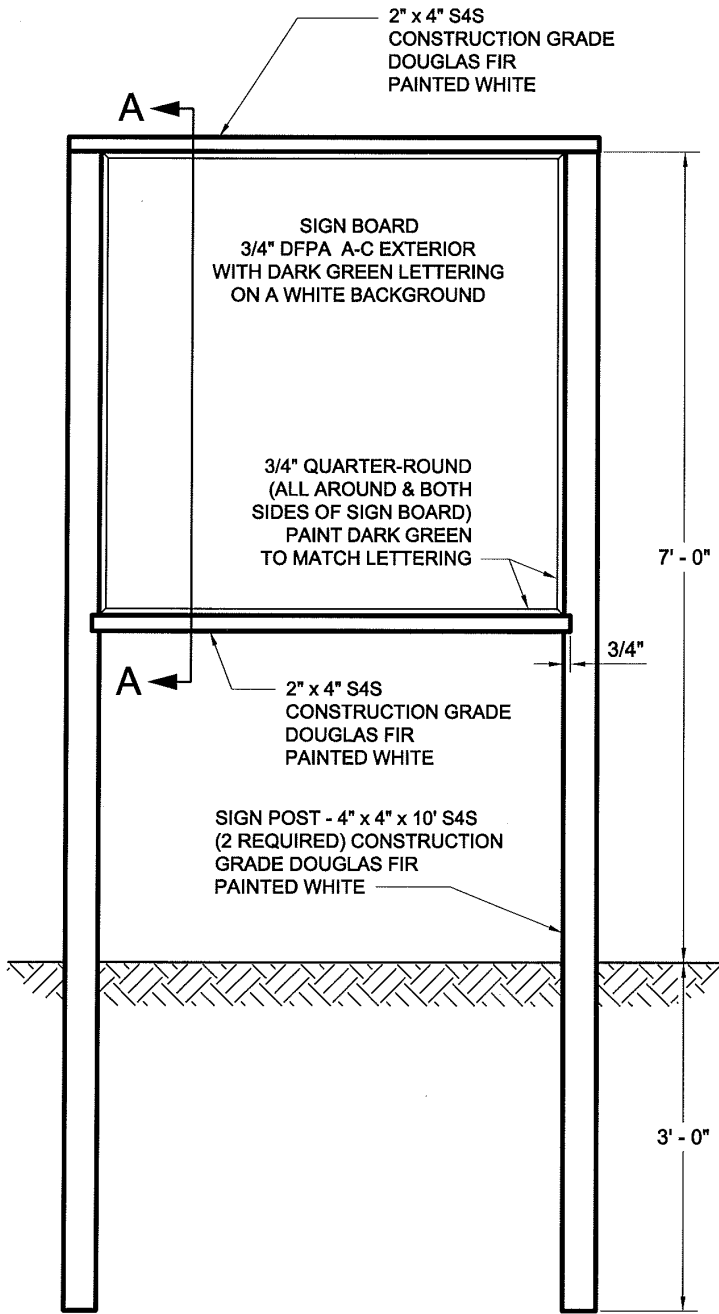

PLAN

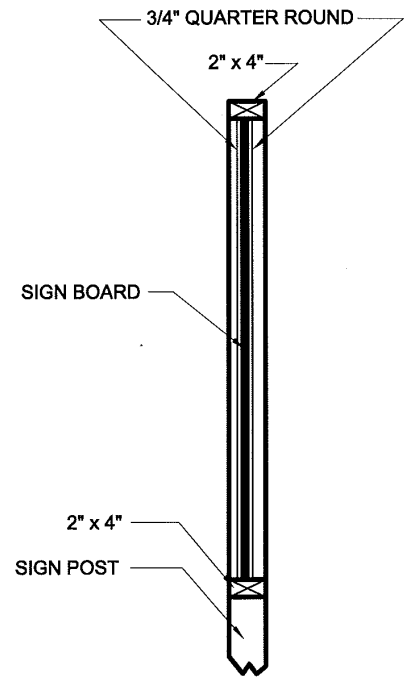

SECTION A - A

**NISQUALLY STATE PARK
NEW FULL SERVICE PARK – PHASE 2**

SECTION 010099 – SURVEYING

PART 1 - GENERAL

1.1 DESCRIPTION OF WORK

- A. This section addresses work covered by construction survey work necessary to establish and maintain alignment and grades necessary for construction.
- B. Set and maintain alignment and grades necessary for construction; including clearing/grubbing limits, grading, utilities, roads, trails, and structures. Except for the data specified to be furnished by the Owner, the Contractor is responsible for calculations, surveying materials and measuring required for setting and maintaining the necessary lines and grades. Furnish copies of calculations and staking data, when requested by Project Representative. AutoCad design data will be supplied by the State per Section 013600 – Digital File Request.
- C. Staking requirements that do not fit field conditions will be reviewed and, if necessary, adjusted by the Engineer. Revisions to the staking information will be provided for completing the work.

1.2 SURVEY CONTROL AND DATA

- A. To facilitate establishment of lines and elevations, Owner will furnish the following survey control and data:
 - 1. Elevation benchmarks, and horizontal control points, for one time only.
 - 2. Provide technical advice, if requested.
- B. Give three weeks' notice to allow adequate time to provide data.

1.3 TOLERANCES

- A. Ensure accuracy of line and elevations within a tolerance of 0.01 foot.
- B. Set subgrade blue tops and surfacing red and yellow tops at 50 foot intervals in tangent sections, 25 foot intervals in curve sections and 10 foot intervals in intersection radii.
- C. In disputes concerning line and elevation accuracy, resolve dispute to Project Representative's satisfaction. Correct discrepancies before proceeding. No additional time or compensation will be provided for corrective work.
- D. Lump sum price for "Surveying" includes full pay costs for labor, tools, survey instruments, materials, other equipment, and traffic control necessary for the setting and maintaining horizontal locations and grades as specified shall be measured and paid in the Base Bid under the Schedule A Bid Item "Staff Residence and Administration Building" and under the Schedule B Bid Item "Nisqually/Ohop Access Improvements".

**NISQUALLY STATE PARK
NEW FULL SERVICE PARK – PHASE 2**

1.4 PAYMENT

- A. Lump sum price for “Surveying” includes full pay costs for labor, tools, survey instruments, materials, other equipment, and traffic control necessary for the setting and maintaining horizontal locations and grades as specified.

PART 2 – PRODUCTS (NOT USED)

PART 3 – EXECUTION

3.1 SURVEYING SERVICES

- A. Contractor shall provide Surveying Services as deemed necessary by the Contractor to define the horizontal and vertical control and staking to implement the contracted scope of work accurately.

3.2 STATIONING

- A. Nisqually/Ohop Access Improvements and Roadway Improvements (Schedule B): provide 100 foot stationing along the length of the Road. Station 0+00 shall begin at the apparent intersection of the Nisqually/Ohop Road centerline and the Mashel Prairie Road. One hundred foot (100’) Stationing shall be measured along the apparent centerline of the existing Nisqually/Ohop gravel road (Roadway Improvements). As reference points throughout the project, Contractor shall install and maintain Stationing Lath at 100’ increments. Install first Stationing Lath at Station 4+00 and end Stationing Lath at Station 72 + 00. Stationing Lath shall be installed at 15’ right angle offsets from the apparent centerline of the gravel road and shall include Stationing written on the Lath. Stationing Lath can be installed either on the left or right side of the centerline stationing.

END OF SECTION

**NISQUALLY STATE PARK
NEW FULL SERVICE PARK – PHASE 2**

SECTION 012300 – ALTERNATE BID ITEMS

PART 1 - GENERAL

1.1 SUMMARY

- A. Section includes administrative and procedural requirements for alternates.

1.2 DEFINITIONS

- A. Alternate: An amount proposed by bidders and stated on the Bid Form for certain work defined in the Bidding Requirements that may be added to or deducted from the base bid amount if Owner decides to accept a corresponding change either in the amount of construction to be completed or in the products, materials, equipment, systems, or installation methods described in the Contract Documents.
 - 1. Alternates described in this Section are part of Work only if accepted by the Commission.
 - 2. The cost or credit for each alternate is the net addition to or deduction from Contract Sum to incorporate alternate into Work. No other adjustments are made to Contract Sum.

1.3 PROCEDURES

- A. Coordination: Modify or adjust affected adjacent work as necessary to completely integrate work of the alternate into Project.
 - 1. Include as part of each alternate, miscellaneous devices, accessory objects, and similar items incidental to or required for a complete installation whether or not indicated as part of alternate.
- B. Execute accepted alternates under the same conditions as other work of Contract.
- C. Schedule: A schedule of alternates is included at the end of this Section. Specification Sections referenced in schedule contain requirements for materials necessary to achieve work described under each alternate.

1.4 REINSTATEMENT OF BID ALTERNATES

- A. The Commission reserves the right to reinstate, within one hundred and twenty (120) calendar days after Notice to Proceed date, any bid alternates not incorporated into the contract, at the stated alternate bid price.

1.5 ORDER OF CONSIDERATION

- A. Bid alternates may be selected in any order or combination by the Commission in any order.

**NISQUALLY STATE PARK
NEW FULL SERVICE PARK – PHASE 2**

PART 2 - PRODUCTS (NOT USED)

PART 3 - EXECUTION

3.1 SCHEDULE OF ALTERNATES

A. Alternate Bid Item A1 – Overlook 1 Spur Trail:

1. Provide Overlook 1 Spur Trail improvements as shown in Drawing B-C4.3 and as described in related specification sections.

**NISQUALLY STATE PARK
NEW FULL SERVICE PARK – PHASE 2**

SECTION 013000 - ADMINISTRATIVE PROCEDURES

PART 1 - GENERAL

1.1 CONDITIONS OF CONTRACT

- A. Contractor shall be thoroughly familiar with the Agreement and provisions of the Project Manual.

1.2 COMMUNICATIONS

- A. The Contractor shall follow the procedure and furnish information to the Owner as follows:
 - 1. Letters to the Owner's Representative: Original and one copy.
 - 2. Drawings and Specifications: Owner will provide electronic files of the Conformed Set (Project Manual and Plans). Three complete paper copies of the Conformed Set will be provided to the General Contractor at no cost to Contractor for the following purposes: one copy for field uses, one copy to remain on site for recording field changes and as-built information, one copy for office uses. One additional copy may be obtained by the General Contractor, at no cost to Contractor, from the Owner for each subcontractor. Additional paper copies may be obtained from the Owner at the cost of reproduction.
 - 3. Communication. All communication concerning the Work shall take place between the Owner and the Contractor or their authorized agents. No other communication shall be recognized. Instructions from Owner will be given to General Contractor or his/her authorized agent (job superintendent) for distribution to subcontractors and tradesmen on job.

1.3 SUBMITTALS PRIOR TO STARTING WORK

- A. Prepare Schedule of Values cost breakdown showing quantities and values for the various parts of the Work. This shall be itemized and match the total of Bid Award.
- B. Materials lists showing all materials proposed for use in the Work and order dates necessary to insure timely delivery to the site.
- C. List of subcontractors proposed for the principal parts of the Work.
- D. Progress Schedule showing proposed dates of commencement and completion of the various parts of the Work. Subdivisions of the schedule shall coincide with order and delivery dates on the material lists.
- E. Certificates of Liability and Property Insurance on forms supplied by Owner.

1.4 PERMITS

- A. Refer to Environmental & Construction Permits.

**NISQUALLY STATE PARK
NEW FULL SERVICE PARK – PHASE 2**

- B. The Contractor shall notify the Owner and coordinate with the permitting authority for extension of all permits that expire prior to final acceptance. The Owner will be responsible for permit fees and/or related extension costs for the Owner furnished permits only.
- C. The Contractor shall comply with the requirements / conditions of the permits.

1.5 OTHER SIGNS

- A. No signs of contractor, subcontractor, or advertising of any kind are to be erected.

1.6 PROTECTION OF MATERIALS

- A. The Contractor is responsible for protection of materials and completed work from vandalism until the work is accepted.

1.7 DUST CONTROL

- A. The Contractor shall be responsible for alleviation or prevention of any dust nuisance arising from the work on this project, by the use of water or dust palliatives as required and as approved by the Owner.

1.8 VANDALISM

- A. The Contractor is hereby advised to take all lawful and prudent precautions against vandalism on any work and equipment connected with this project. The Owner will not in any way be held responsible or financially accountable for vandalism or be responsible for repairing or replace property impacted by vandalism.

1.9 WEATHER

- A. Since work will be done during inclement weather, each bidder shall satisfy themselves before submitting their bid to the hazards likely to arise from weather conditions. Complete weather records and reports may be obtained from any U.S. Weather Bureau Office.

1.10 EROSION CONTROL

- A. The Contractor shall be responsible at all times for erosion control during construction and for repair of any completed work damaged by erosion - until final acceptance.

1.11 MAINTENANCE OF STREETS, UTILITIES, ETC.

- A. The Contractor shall be responsible at all times for the maintenance of streets and other utilities affected by construction operations. Streets and utilities shall be kept in full operation during the entire course of the project. Debris and rubbish shall not be permitted to accumulate, and all premises shall be maintained in a neat and workman-like condition, as determined by the Owner.

**NISQUALLY STATE PARK
NEW FULL SERVICE PARK – PHASE 2**

- B. In the event the Contractor fails to conform to these requirements, the Owner shall have the right to have the work done by others and the cost will be deducted from monies due the Contractor.

1.12 EXISTING SITE TOPOGRAPHY

- A. The existing topography is shown as contour lines and spot elevations as indicated in the legend on the grading plans. Notify Owner immediately should actual conditions vary significantly from those shown.

1.13 SUBMITTALS DURING CONSTRUCTION

- A. Shop drawings and samples in accordance with Project Manual.
- B. Written statement to Owner's Representative of completion and request for Final Inspection.

1.14 NUMBER OF SPECIFIED ITEMS REQUIRED

- A. Wherever these specifications, an article, device, or piece of equipment is referred to in the singular number, such reference applies to all and as many such articles as are shown on the drawings or required to complete the installation.

1.15 DIMENSIONS AND MEASUREMENTS

- A. Dimensions govern. Do not scale drawings, unless so indicated on the plans. Check all dimensions in the field and verify them with respect to the adjacent or incorporated work.

PART 2 - PRODUCTS (NOT USED)

PART 3 - EXECUTION (NOT USED)

END OF SECTION

**NISQUALLY STATE PARK
NEW FULL SERVICE PARK - PHASE 2**

SECTION 013300 - SUBMITTAL PROCEDURES

PART 1 - GENERAL

1.1 WORK IN THIS SECTION

- A. General: The types of submittal requirements specified in this Section include Shop Drawings, product data, Samples, and miscellaneous Work-related submittals. Specialized submittal requirements are specified in applicable Sections for each unit of Work. Refer to other Division 01 Sections and other Contract documents for requirements of administrative submittals.
1. Shop Drawings: Specially prepared technical data for this Project, including Drawings, diagrams, performance curves, data sheets, schedules, templates, patterns, reports, calculations, instructions, measurements, and similar information not in standard printed form for general application to several projects.
 2. Product Data: Standard printed information on materials, products and systems; not specially prepared for this Project, other than the designation of selections from among available choices printed therein.
 3. Samples: Fabricated and unfabricated physical examples of materials, products and units of Work; both as completed units and as smaller portions of units of Work; either for limited visual inspection or (where indicated) for more detailed testing and analysis.
 4. Miscellaneous: Submittals related directly to the Work (non-administrative) include warranties, informational, maintenance agreements, workmanship bonds, Project photographs, survey data and reports, physical Work records, quality testing and certifying reports, copies of industry standards, record drawings, field measurement data, operating and maintenance materials, overrun stock, and similar information, devices and materials applicable to the Work and not processed as Shop Drawings, product data or Samples. See Specification Sections.

1.2 RELATED REQUIREMENTS

- A. Section 017700 – Closeout Procedures

1.3 GENERAL SUBMITTAL REQUIREMENTS

- A. Coordination and Sequencing: Coordinate preparation and processing of submittals with performance of the Work so that Work will not be delayed by submittals. Coordinate and sequence different categories of submittals for same Work, and for interfacing units of Work, so that one will not be delayed for coordination with another.
- B. Preparation of Submittals: Provide permanent marking on, or with, each submittal to identify Project, date, Contractor, sub-contractor, submittal name and similar information to distinguish it from other submittals.

**NISQUALLY STATE PARK
NEW FULL SERVICE PARK - PHASE 2**

1.4 SPECIFIC SUBMITTAL REQUIREMENTS

A. General:

1. Except as otherwise indicated in individual Work Sections, comply with requirements specified herein for each indicated category of submittal.
2. Provide and process intermediate submittals, where required between initial and final, similar to initial submittals.
3. Include a transmittal with all submittals.

B. Shop Drawings:

1. General: No claims for extras may be initiated, based on Work shown on Shop Drawings.
2. Where Work of more than one sub-contractor is involved, submit composite Drawings, clearly defining the Work of each separate sub-contractor.
3. No extension of time in respect to the final completion date of building will be granted to Contractor because of failure to have any Shop Drawings submitted in ample time to allow for checking and approval.
4. Verify all dimensions by taking field measurements. Do not begin Work until required submittals have been returned by the Engineer with stamp and initials indicating review. If Work has been done which is contrary to the approved Drawings, it will be corrected at no additional cost to the Commission. Maintain one complete set of shop drawings at the site for use by the Engineer.
5. Submit four (4) copies. Engineer will retain two (2) copies and return two (2) copies.

C. Product Data:

1. General:
 - a. Collect required data into one submittal for each unit of Work or system; and mark each copy to show which choices and options are applicable to Project. Include manufacturer's standard printed recommendations for application and use, compliance with standards, application of labels and seals, notation of field measurements which have been checked, and modify details as required for application into the Work. Include color selection information where necessary.
 - b. Do not proceed with installation of materials, products or systems until final copy of applicable product data is in possession of Installer. Maintain one complete set of product data at the site for use by Engineer.
2. Preparation and Processing: Do not submit product data, or allow its use on the Project, until compliance with requirements of Contract documents has been confirmed by Contractor. Submittal is for information and record, unless otherwise indicated. Initial submittal is final submittal unless returned by Engineer, marked with an "Action" which indicates an observed noncompliance.
3. Submit four (4) copies. Engineer will retain two (2) copies and return two (2) copies to the Contractor.

**NISQUALLY STATE PARK
NEW FULL SERVICE PARK - PHASE 2**

D. Samples:

1. General: Provide units identical with final condition of proposed materials or products for the Work. Include "range" Samples (not less than three (3) units) where there are unavoidable variations between units of each set. Provide full set of optional Samples where Engineer's selection is required. Prepare Samples to match Engineer's sample where indicated. Include information with each sample to show generic description, source or product name and manufacturer, limitations, and compliance with standards. Samples are submitted for review and confirmation of color, pattern, texture and "kind" by Engineer. Engineer will not "test" Samples (except as otherwise indicated) for compliance with other requirements, which are, therefore, for exclusive responsibility of the Contractor.
2. Processing: Submit two (2) sets of Samples for Engineer's review and "Action"; one (1) set will be returned. Large Samples, which may be incorporated into the Work, may be submitted singly.
3. Reusable Samples: Returned Samples which are intended or permitted to be incorporated in the Work are so indicated in the individual Work sections and must be in undamaged condition at time of use.

E. Warranties and Guarantees: In addition to copies desired for Contractor's use, furnish three (3) executed copies, except furnish additional copies where required for maintenance manuals.

F. Survey Data: Refer to other Sections for specific general requirements on property surveys, field measurements, quantitative records of actual Work, damage surveys, photographs and similar data required by individual Work Sections of these specifications. None of specified copies will be returned.

1.5 ACTION ON SUBMITTALS

A. Engineer's Action: Engineer will review each submittal, mark with "Action", and where possible return within two (2) weeks of receipt. Where submittal must be held for coordination, they will be returned to the Contractor within two (2) weeks of receipt for the Contractor to resubmit when it is appropriate.

1. Final Unrestricted Release: Work may proceed, provided it complies with Contract documents, when submittal is returned with marking: "Approved as Submitted".
2. Final-But-Restricted Release: Work may proceed, provided it complies with notations and corrections on submittal and with Contract documents, when submittal is returned with the marking: "Approved as Noted".
3. Returned and Rejected: Do not proceed with Work. Submittal item is not acceptable and may not be used on the Project when noted as "Not Approved".

PART 2 - PRODUCTS (NOT USED)

PART 3 - EXECUTION (NOT USED)

END OF SECTION

NISQUALLY STATE PARK
NEW FULL SERVICE PARK – PHASE 2

SECTION 013500 – PROJECT MEETINGS

PART 1 - GENERAL

1.1 GENERAL

- A. The construction of this project will be planned and recorded with a conventional Gantt Chart. The chart shall be used for coordination, monitoring, and payment of all work under the contract including all activity of subcontractors, vendors, and suppliers.
- B. Contractor is responsible for preparing the initial schedule in the form of an Activity on arrow diagram. All costs incurred by Contractor in preparing the Schedule shall be borne by the Contractors as a part of its responsibility this contract.
- C. The initial schedule as reviewed by the Owner and signed by the Contractor will become the Original Baseline Schedule. The Contractor shall preserve the Original Baseline Schedule in its original form on an electronic readable medium until final payment has been made and all claims arising from the Project are resolved.
- D. The Contractor shall utilize the most recently updated detailed Construction Schedule in planning, scheduling, coordinating, performing, and controlling the work under this contract (including all activities of subcontractors, equipment vendors and suppliers, and scheduling the delivery of “Furnished by Owner, Installed by Contractor” (FOIC) items).
- E. The Owner’s review of schedules shall not constitute approval or adoption by the Owner of the Contractor’s plan or schedule for construction method or plan reflected. It shall not relieve the Contractor from the sole responsibility for the accuracy of the schedule and its compliance with all Contract requirements.
- F. Progress schedules shall be revised weekly and presented at the weekly construction progress meeting.

1.2 CONTRACTOR'S CONSTRUCTION SCHEDULE

- A. Provide a horizontal bar chart type construction schedule and submit for initial review at the Preconstruction Conference.
 - 1. Provide separate time bar for each significant construction activity measured in days.
 - 2. Provide the same breakdown of units for the Work as indicated in the "Schedule of Values".
 - 3. Within each time bar indicate estimated completion percentage in 10 percent increments. As work progresses, place contrasting mark in each bar to indicate Substantial and Final Completion.
 - 4. Prepare schedule on a sheet of sufficient size to show entire construction period.
 - 5. Coordinate the Contractor's construction schedule with the schedule of values.
 - 6. Indicate Physical Completion on the schedule.

NISQUALLY STATE PARK
NEW FULL SERVICE PARK – PHASE 2

- B. The construction time, for the entire project or any milestone, shall not exceed the specified contract time. In the event that any milestone date or contract completion date is exceeded in the schedule, logic and/or time estimates will be revised.
- C. Following review of the initial schedule, if revisions to the proposed schedule are required, the Contractor make revisions before the next weekly construction progress meeting. Failure to finalize the schedule by that date will result in withholding all contract payments until the schedule is finalized.

1.3 SCHEDULE REQUIREMENTS

- A. All activities on Gantt Chart shall include:
 - 1. Activity nodes.
 - 2. Activity description.
 - 3. Activity duration.
 - 4. Any and all major construction activities.
 - 5. Tentative dates for Inspections and Testing required by Specifications and Project Permits.
- B. The activity on Gantt Chart shall show the sequence and interdependence of all activities required for complete performance of all items of work under this contract, including shop drawing submittals and approvals and fabrication and delivery activities. The Project critical path shall be clearly identified on the chart.
- C. The activities are to be described so that the work is readily identifiable, and the progress of each activity can be readily measured. For each activity the Contractor shall identify the trade or subcontractor performing the work, the duration of the activity in calendar days, the manpower involved by trade, the equipment involved, the location of the work, and a dollar value of the activity. The dollar value assigned to each activity is to be reasonable and based on the amount of labor, materials, and equipment involved. When added together the dollar value of all activities are to equal the contract price.
- D. The Contractor shall also provide the following information: workdays per week, holidays, number of shifts per day, number of hours per shift, and major equipment used.
- E. Any activity on arrow diagram submitted by the Contractor shall be computer plotted. Regardless of the type of diagram, the network must be legible, readable, and understandable. Network diagram will be on standard D letter or Tabloid sheets. Standard media driven printouts may be used if approved by the Owner.

1.4 SCHEDULE UPDATES AND PROGRESS PAYMENTS

- A. Job site progress meetings will be held weekly by the Owner, Owner's Representative, and Contractor for the purpose of updating the project work schedule and determining the appropriate amount of partial payment due the Contractor. Progress will be reviewed to verify finish dates of completed activities, remaining duration of the completed activities, and any proposed logic and/or time estimate revisions.

NISQUALLY STATE PARK
NEW FULL SERVICE PARK – PHASE 2

- B. The Contractor will revise activity on arrow diagrams for the following: delay in completion of any critical activity; actual prosecution of the work which is, as determined by the Owner, significantly different than that represented on the schedule; or the addition, deletion, revision of activities required by contract modification. The contract completion time will be adjusted only for causes specified in this contract.
 - 1. The revised schedule shall become the complete “Revised Baseline Schedule” for the Project and will thereafter serve as the basis for adjustment of the time of performance of the work.
- C. If the Contractor does seek a time extension of any milestone or contract completion date, it shall furnish documentation as required by the Owner to enable the Owner to determine whether a time extension is appropriate under the terms of the contract.
- D. If Inspections and Testing needs to be postponed, Contractor shall notify Owner, Inspector and Testing Agent at least 24 hours in advance.

PART 2 - PRODUCTS (NOT USED)

PART 3 EXECUTION (NOT USED)

END OF SECTION

**NISQUALLY STATE PARK
NEW FULL SERVICE PARK – PHASE 2**

SECTION 013501 – INADVERTENT DISCOVERIES OF CULTURAL RESOURCES AND HUMAN SKELETAL REMAINS

PART 1 - GENERAL

1.1 PROJECT SPECIFIC REQUIREMENTS

- A. Cultural resource sites are known to exist in the vicinity of the Work area see Special Conditions for requirements.

1.2 EMERGENCY CONTACTS

WSPRC Archaeologists

Jennifer Wilson, Archaeology Program Manager	(360) 787-6511 (cell)
Email: jennifer.wilson@parks.wa.gov	(360) 902-8637 (office)
Shari Silverman, Archaeologist SW Region	(435) 260-9894 (cell)
Email: shari.silverman@parks.wa.gov	(360) 902- 8640 (office)
Kayley Bass, Archaeologist SW Region	(360) 701-1277 (cell)
Emails: kayley.bass@parks.wa.gov	
Sarah DuBois, Archaeologist Eastern Region	(360) 972-5884 (cell)
Email: sarah.dubois@parks.wa.gov	(509) 665-4336 (office)
Ayla Aymond, Archaeologist Eastern Region	(509) 743-8251 (cell)
Email: ayla.aymond@parks.wa.gov	
Sean Stcherbinine, Archaeologist NW Region	(360) 770-1419 (cell)
Email: sean.stcherbinine@parks.wa.gov	
Laura Syvertson, Archaeologist NW Region	(360) 770-0444 (cell)
Email: laura.syvertson@parks.wa.gov	
Maurice Major, Stewardship Archaeologist	(360) 701-6218 (cell)
Email: maurice.major@parks.wa.gov	(360) 902-8503 (office)

WSPRC Curator of Collections/NAGPRA Specialist

Alicia L. Woods, Statewide Curator of Collections & NAGPRA Specialist (360) 586-0206 (office)

State Physical Anthropologist

Guy Tasa, PhD, Dept. of Archaeology and Historic Preservation (360) 790-1633 (cell)

Assistant State Physical Anthropologist

Julie Berger, Dept. of Archaeology and Historic Preservation(360) 890-2633 (cell)

County Coroner/Examiner

Thomas B. Clark III, Pierce County Medical Examiner's Office (253) 798-6494 (office)
Email: tclark@co.pierce.wa.us

Area Manager

Janet Halstead, Area Manager (360) 753-1519

**NISQUALLY STATE PARK
NEW FULL SERVICE PARK – PHASE 2**

Region Manager

Stephanie Simek, Washington State Parks and Recreation Commission (360) 902-0934

Local Law Enforcement (if can't get ahold of any park staff)

Pierce County Sheriff's Office (911, if an emergency; non-emergency call (253) 287-4455)

1.3 INADVERTENT DISCOVERIES OF CULTURAL RESOURCES AND HUMAN SKELETAL REMAINS

- A. Many of Washington's most important heritage sites reside on lands owned or managed by the Washington State Parks and Recreation Commission (WSPRC). Nearly all Washington State Parks contain one or more important historic buildings, structures, or archaeological sites. For this reason, archaeological surveys and historic building inventories are ordinarily commissioned as a part of background analysis and information gathering for park developments and undertakings. Results of these surveys are used during project planning to ensure every effort is made to avoid impacts to cultural resources. Yet, despite these efforts, there **always** remains some potential for unanticipated discoveries while working in Washington State Parks.
- B. All unanticipated discoveries, both cultural resources and human skeletal remains, are subject to all applicable federal and state statutes, regulations, and executive orders. For these reasons, the Inadvertent Discovery Plan (IDP) provides useful guidance and instructions for circumstances when cultural resources or human skeletal remains are found. Please carefully read these instructions. If you have any questions, please contact the appropriate WSPRC Area Manager or the WSPRC archaeologist assigned to the undertaking. It is also strongly recommended that anyone conducting ground-disturbing activities watch the training video produced by Washington State Dept of Ecology: [Inadvertent Discovery of Cultural Resources or Human Remains: Training for Field Staff](#). This IDP for cultural resources and human skeletal remains is based on [RCW 27.53](#), [RCW 68.50.645](#), [RCW 27.44.055](#), and [RCW 68.60.055](#) and [recommended language](#) from the Department of Archaeology and Historic Preservation (DAHP).

1.4 INADVERTENT DISCOVERY PLAN FOR CULTURAL RESOURCES

- A. If cultural resources are found during a project, activity in the immediate area of the find should be discontinued (**stop**), the area secured (**protect**), and the WSPRC archaeologists notified to assess the find (**notify**). *When in doubt, assume the material is a cultural resource and implement the IDP outlined below.*
- B. **Recognizing Cultural Resources-Types of Historic/Prehistoric Artifacts and/or Activity Areas That May Be Found**
1. Artifacts- Both historic and prehistoric artifacts may be found exposed in backhoe trenches or back dirt piles.
 - a) Prehistoric artifacts may range from finished tools such as stone pestles, arrowheads/projectile points, shell beads, or polished bone tools to small pieces or "flakes" or "chips" of exotic stone such as chert, Jasper, or obsidian.
 - b) Historic artifacts may include older (more than 50 years) nails, plates/ceramics, bottles, cans, coins, glass insulators, or bricks.

**INADVERTENT DISCOVERIES OF CULTURAL RESOURCES AND HUMAN SKELETAL
REMAINS – 013501 - 2**

12/16/2022

**NISQUALLY STATE PARK
NEW FULL SERVICE PARK – PHASE 2**

- c) Old abandoned industrial materials from farming, logging, railways, lighthouses, and military installations.
 2. Activity Area/Cultural Features- While excavating trench lines look for evidence of buried activity areas/cultural features such as old campfire hearths or buried artifacts.
 - a) An area of charcoal or very dark stained soil with artifacts or burned rocks may be a fire hearth.
 - b) A concentration of shell with or without artifacts may be shell midden deposits.
 - c) Modified or stripped trees, often cedar or aspen, or other modified natural features, such as rock drawings or carvings
 3. Historic building foundation/structural remains- During excavation, buried historic structures (e.g., privies, building foundations) that are more than 50 years old may be found.
 4. Bone- Complete or broken pieces of bones may be discovered exposed in trench walls or in back dirt piles. Bone of recent age is usually transparent or white in color. Older bone is usually found in various shades of brown. Burned bone is usually black or, if heavily burned, bluish-white.
- C. STEPS TO TAKE IF A CULTURAL RESOURCE IS FOUND DURING CONSTRUCTION
1. **Stop** if a cultural resource(s) is observed or suspected, all work within the immediate area of the discovery must stop.
 2. **Protect** the area from further disturbance. Do not touch, move, or further disturb the exposed materials/artifacts. Create a protected area with temporary fencing, flagging, stakes, or other clear markings that is large enough (30 feet or larger) to protect the discovery location area. The WSPRC archaeologist can help determine the size of the protected area. Do not permit vehicles, equipment, or unauthorized personnel to traverse the discovery site.
 3. **Notify** the WSPRC archaeologist. If the area needs to be secured, notify the Park Ranger or Park staff as well.
 4. If requested by the WSPRC archaeologist, take photographs with a scale (e.g., pen, coin, etc.) and collect geospatial information of the discovery site to document the initial finds.
- D. WHAT NOT TO DO IF A CULTURAL RESOURCE IS FOUND DURING CONSTRUCTION
1. Do not remove any artifacts from the site of the discovery.
 2. Do not dig out objects protruding from any trench walls as this may cause further damage to artifacts and/or destroy important contextual information.
 3. Do not share any information about the find, including on social media, except as necessary to implement the IDP.
- E. WHAT HAPPENS NEXT?
1. The find will be assessed by a professional archaeologist (may be a WSPRC archaeologist or an archaeology consultant).
 - a) If the find is not a cultural resource, construction work may resume.
 - b) If the find is a cultural resource, the WSPRC archaeologist will contact the DAHP and affected Tribes, as appropriate, to develop a suitable treatment plan for the resource.

**NISQUALLY STATE PARK
NEW FULL SERVICE PARK – PHASE 2**

2. Construction work may resume in the protected area after the WSPRC archaeologist assigned to the undertaking has determined that the find has been adequately investigated and, if necessary, a treatment plan and monitor are in place to protect any remaining archaeological deposits.

1.5 INADVERTENT DISCOVERY PLAN FOR HUMAN SKELETAL REMAINS

- A. Native American burials and historic grave sites are uncommon features on Washington State Park lands. These remains, as well as any associated artifacts or funerary objects, are protected under state law and, if the park is a federal lease, applicable federal law. If you discover human remains (or bones that you believe may be human remains) during construction, please follow these important instructions. It is imperative that reporting and treatment of any human remains found during construction or any ground-disturbing activities are treated with utmost dignity and respect.

B. Steps to Take If Human Skeletal Remains are Found During Construction

1. **Stop** if human skeletal remains observed or suspected, all work within the immediate area of the discovery must stop.
2. **Protect** the area from further disturbance. Do not touch, move, or further disturb the remains. Cover the remains with a tarp or other materials (not soil or rocks) for temporary protection in place and shield them from being photographed. Create a protected area with temporary fencing, flagging, stakes, or other clear markings that is large enough (30 feet or larger) to protect the discovery location area. The WSPRC archaeologist can help determine the size of the protected area. Do not permit vehicles, equipment, or unauthorized personnel to traverse the discovery site.
3. **Notify** law enforcement and the appropriate county medical examiner/coroner as soon as possible. If you are unsure if the remains are human, the physical anthropologist at DAHP may be called. Also notify the Park Ranger, the WSPRC archaeologist, and the WSPRC Curator of Collections/NAGRPA Specialist of the discovery of the remains.
4. If requested by law enforcement, the county coroner/examiner, the DAHP physical anthropologist, or the WSPRC archaeologist, take photographs with a scale (e.g., pen, coin, etc.) and geospatial information of the discovery site to document the initial finds.

C. What Not to Do If Human Skeletal Remains are Found During Construction

1. Do not pick up or remove anything.
2. Do not take any photographs of the remains unless instructed to do so by law enforcement, the county coroner/examiner, the DAHP physical anthropologist, or the WSPRC archaeologist. If pictures are requested, be prepared to photograph them with a scale (e.g., pen, coin, etc.) and collect geospatial information of the remains.
3. Do not call 911 unless you cannot reach law enforcement or the coroner/examiner by other means.
4. Do not share any information about the find, including on social media, except as necessary to implement the IDP.

D. What Happens Next?

1. The county medical examiner/coroner will assume jurisdiction over the human skeletal remains and decide whether those remains are forensic (crime-related) or non-forensic.

**NISQUALLY STATE PARK
NEW FULL SERVICE PARK – PHASE 2**

- a) If forensic, the county medical examiner/coroner will retain jurisdiction over the remains.
- b) If non-forensic, the county medical examiner/coroner will report that finding to the DAHP who will then take jurisdiction over the remains. The DAHP will notify any appropriate cemeteries and all affected Tribes of the remains. The State Physical Anthropologist will decide whether the remains are Indian or Non-Indian and report that finding to any appropriate cemeteries and the affected Tribes. The DAHP will then handle all consultation with the affected parties as to the future preservation, excavation, and disposition of the remains.

Note: The WSPRC archaeologist assigned to the undertaking will be coordinating and consulting with the DAHP, affected Tribes, and other groups as necessary. Additionally, WSPRC's Curator of Collections/NAGPRA Specialist should be included on all written and/or verbal correspondence until the remains have been officially transferred from WSPRC's possession to an outside authority. Until the remains are transferred off of WSPRC's property, it is the responsibility of the Curator of Collections/NAGPRA Specialist to document and track the information regarding all human remains and associated funerary objects (including all material from excavation areas/units from which the human remains were removed).

- 2. Construction work may resume in the protected area after the WSPRC archaeologist assigned to the undertaking has determined that the find has been adequately investigated and, if necessary, a treatment plan and monitor are in place.

END OF SECTION

**NISQUALLY STATE PARK
NEW FULL SERVICE PARK - PHASE 2**

SECTION 013600 – DIGITAL FILE REQUEST FORM

The Contractor may request the digital file of the Site and Grading Plans to facilitate construction survey by filling out and submitting this form. Digital files will not be distributed during the Bidding process.

Date: _____

Contractor Requesting Digital Files: _____

Name of Contractor's Staff, Contractor's address, phone, and email: _____

Digital Files (Drawings) Requested: _____

Consultant Authorization: Name: _____

Signature: _____

Date: _____

The undersigned acknowledges that the use of information contained on these files is at their own risk. The information contained herein may not include final information included in the Contract Documents, and/or Addenda (Amendments) revisions. The accuracy of information, scale and dimensions is not guaranteed. The undersigned agrees to indemnify and hold harmless the Owner, Consultant, their agents, employees, and sub-consultants from all claims, losses, expenses, damages and liability, including attorney's fees, arising out of their use of the information contained herein. The undersigned warrants that he/she has authority to sign and bind the company for and to the foregoing.

Acknowledged for: _____
(Company Name)

By: _____
(Name and Title)

Signature: _____ Date: _____

END OF SECTION

**NISQUALLY STATE PARK
NEW FULL SERVICE PARK - PHASE 2**

SECTION 014000 - QUALITY REQUIREMENTS

PART 1 - GENERAL

1.1 SUMMARY

- A. Section includes administrative and procedural requirements for quality assurance and quality control.
- B. Testing and inspecting services are required to verify compliance with requirements specified or indicated. Testing/Inspections compaction, rebar, concrete, asphalt, and steel will be paid for by the Owner. All other testing shall be paid for by the Contractor. These services do not relieve Contractor of responsibility for compliance with the Contract Document requirements.
 - 1. Specified tests, inspections, and related actions do not limit Contractor's other quality-assurance and -control procedures that facilitate compliance with the Contract Document requirements.
 - 2. Requirements for Contractor to provide quality-assurance and -control services required by Project Representative, Owner, or Authorities Having Jurisdiction are not limited by provisions of this Section.
- C. Related Requirements:
 - 1. Divisions 02 through 49 Sections for specific test and inspection requirements.

1.2 DEFINITIONS

- A. Quality-Assurance Services: Activities, actions, and procedures performed before and during execution of the Work to guard against defects and deficiencies and substantiate that proposed construction will comply with requirements.
- B. Quality-Control Services: Tests, inspections, procedures, and related actions during and after execution of the Work to evaluate that actual products incorporated into Work and completed construction comply with requirements. Services do not include contract enforcement activities performed by Project Representative.
- C. Mockups: Full-size physical assemblies that are constructed on-site. Mockups are constructed to verify selections made under Sample submittals; to demonstrate aesthetic effects and, where indicated, qualities of materials and execution; to review coordination, testing, or operation; to show interface between dissimilar materials; and to demonstrate compliance with specified installation tolerances. Mockups are not Samples. Unless otherwise indicated, approved mockups establish the standard by which the Work will be judged.
- D. Preconstruction Testing: Tests and inspections performed specifically for Project before products and materials are incorporated into the Work, to verify performance or compliance with specified criteria.

**NISQUALLY STATE PARK
NEW FULL SERVICE PARK - PHASE 2**

- E. Product Testing: Tests and inspections that are performed by an NRTL, an NVLAP, or a testing agency qualified to conduct product testing and acceptable to Authorities Having Jurisdiction, to establish product performance and compliance with specified requirements.
- F. Source Quality-Control Testing: Tests and inspections that are performed at the source, e.g., plant, mill, factory, or shop.
- G. Field Quality-Control Testing: Tests and inspections that are performed on-site for installation of the Work and for completed Work.
- H. Testing Agency: An entity engaged to perform specific tests, inspections, or both. Testing laboratory shall mean the same as testing agency.
- I. Installer/Applicator/Erector: Contractor or another entity engaged by Contractor as an employee, Subcontractor, or Sub-subcontractor, to perform a particular construction operation, including installation, erection, application, and similar operations.
 - 1. Use of trade-specific terminology in referring to a trade or entity does not require that certain construction activities be performed by accredited or unionized individuals, or that requirements specified apply exclusively to specific trade(s).
- J. Experienced: When used with an entity or individual, "experienced" means having successfully completed a minimum of five previous projects similar in nature, size, and extent to this Project; being familiar with special requirements indicated; and having complied with requirements of authorities having jurisdiction.

1.3 CONFLICTING REQUIREMENTS

- A. Referenced Standards: If compliance with two or more standards is specified and the standards establish different or conflicting requirements for minimum quantities or quality levels, comply with the most stringent requirement. Refer conflicting requirements that are different, but apparently equal, to Project Representative for a decision before proceeding.
- B. Minimum Quantity or Quality Levels: The quantity or quality level shown or specified shall be the minimum provided or performed. The actual installation may comply exactly with the minimum quantity or quality specified, or it may exceed the minimum within reasonable limits. To comply with these requirements, indicated numeric values are minimum or maximum, as appropriate, for the context of requirements. Refer uncertainties to Project Representative for a decision before proceeding.

1.4 QUANTITY SHEETS/WEIGHT TICKETS

- A. For bulk items, supply quantity sheets (load receipts) to account for each load delivered to the jobsite. Deliver quantity sheets to Inspector on job at delivery time. If Inspector is not on job, deliver quantity sheets on a daily basis to place designated by Project Representative.
- B. No payment shall be made for materials delivered for which quantity tickets have not been turned into Inspector or delivered to designated place at end of working day. Backdated tickets are not acceptable as a basis for payment, except at Project Representative's discretion.

**NISQUALLY STATE PARK
NEW FULL SERVICE PARK - PHASE 2**

- C. If bid item for material to be delivered to jobsite is stated in TONS, only weight slips from approved scale are acceptable for payment purposes, unless approved in advance by Project Representative.
- D. No payment for materials will be made until proper accounting has been made. Final quantity records are approved by Project Representative, with payment at Project Representative's discretion.

1.5 INFORMATIONAL SUBMITTALS

- A. Testing Agency Qualifications: For testing agencies specified in "Quality Assurance" Article to demonstrate their capabilities and experience. Include proof of qualifications in the form of a recent report on the inspection of the testing agency by a recognized authority.

1.6 REPORTS AND DOCUMENTS

- A. Test and Inspection Reports: Prepare and submit certified written reports specified in other Sections. Include the following:
 - 1. Date of issue.
 - 2. Project title and number.
 - 3. Name, address, and telephone number of testing agency.
 - 4. Dates and locations of samples and tests or inspections.
 - 5. Names of individuals making tests and inspections.
 - 6. Description of the Work and test and inspection method.
 - 7. Identification of product and Specification Section.
 - 8. Complete test or inspection data.
 - 9. Test and inspection results and an interpretation of test results.
 - 10. Record of temperature and weather conditions at time of sample taking and testing and inspecting.
 - 11. Comments or professional opinion on whether tested or inspected Work complies with the Contract Document requirements.
 - 12. Name and signature of laboratory inspector.
 - 13. Recommendations on retesting and reinspecting.
- B. Manufacturer's Field Reports: Prepare written information documenting tests and inspections specified in other Sections. Include the following:
 - 1. Name, address, and telephone number of representative making report.
 - 2. Statement on condition of substrates and their acceptability for installation of product.
 - 3. Summary of installation procedures being followed, whether they comply with requirements and, if not, what corrective action was taken.
 - 4. Results of operational and other tests and a statement of whether observed performance complies with requirements.
 - 5. Other required items indicated in individual Specification Sections.
- C. Permits, Licenses, and Certificates: For Owner's records, submit copies of permits, licenses, certifications, inspection reports, releases, jurisdictional settlements, notices, receipts for fee

**NISQUALLY STATE PARK
NEW FULL SERVICE PARK - PHASE 2**

payments, judgments, correspondence, records, and similar documents, established for compliance with standards and regulations bearing on performance of the Work.

1.7 QUALITY ASSURANCE

- A. General: Qualifications paragraphs in this article establish the minimum qualification levels required; individual Specification Sections specify additional requirements.
- B. Manufacturer Qualifications: A firm experienced in manufacturing products or systems similar to those indicated for this Project and with a record of successful in-service performance, as well as sufficient production capacity to produce required units.
- C. Fabricator Qualifications: A firm experienced in producing products similar to those indicated for this Project and with a record of successful in-service performance, as well as sufficient production capacity to produce required units.
- D. Installer Qualifications: A firm or individual experienced in installing, erecting, or assembling work similar in material, design, and extent to that indicated for this Project, whose work has resulted in construction with a record of successful in-service performance.
- E. Professional Engineer Qualifications: A professional engineer who is legally qualified to practice in jurisdiction where Project is located and who is experienced in providing engineering services of the kind indicated. Engineering services are defined as those performed for installations of the system, assembly, or product that are similar in material, design, and extent to those indicated for this Project.
- F. Specialists: Certain Specification Sections require that specific construction activities shall be performed by entities who are recognized experts in those operations. Specialists shall satisfy qualification requirements indicated and shall be engaged for the activities indicated.
 - 1. Requirements of Authorities Having Jurisdiction shall supersede requirements for specialists.
- G. Testing Agency Qualifications: An NRTL, an NVLAP, or an independent agency with the experience and capability to conduct testing and inspecting indicated, as documented according to ASTM E 329 Standard Specification for Agencies Engaged in the Testing and/or Inspection of Materials Used in Construction; and with additional qualifications specified in individual Sections; and, where required by Authorities Having Jurisdiction, that is acceptable to authorities.
 - 1. NRTL: A nationally recognized testing laboratory according to 29 CFR 1910.7.
 - 2. NVLAP: A testing agency accredited according to NIST's National Voluntary Laboratory Accreditation Program.
- H. Manufacturer's Representative Qualifications: An authorized representative of manufacturer who is trained and approved by manufacturer to observe and inspect installation of manufacturer's products that are similar in material, design, and extent to those indicated for this Project.

**NISQUALLY STATE PARK
NEW FULL SERVICE PARK - PHASE 2**

- I. Mockups: Before installing portions of the Work requiring mockups, build mockups for each form of construction and finish required to comply with the following requirements, using materials indicated for the completed Work:
1. Build mockups in location and of size indicated or, if not indicated, as directed by Project Representative.
 2. Notify Project Representative seven days in advance of dates and times when mockups will be constructed.
 3. Demonstrate the proposed range of aesthetic effects and workmanship.
 4. Obtain Project Representative's approval of mockups before starting work, fabrication, or construction.
 - a. Allow three days for initial review and each re-review of each mockup.
 5. Maintain mockups during construction in an undisturbed condition as a standard for judging the completed Work.
 6. Demolish and remove mockups when directed unless otherwise indicated.

1.8 QUALITY CONTROL

- A. Owner Responsibilities: Where quality-control services are indicated as Owner's responsibility, Owner will engage a qualified testing agency to perform these services.
1. Owner will furnish Contractor with names, addresses, and telephone numbers of testing agencies engaged and a description of types of testing and inspecting they are engaged to perform.
 2. Costs for retesting and reinspecting construction that replaces or is necessitated by work that failed to comply with the Contract Documents will be charged to Contractor.
- B. Contractor Responsibilities: Tests and inspections not explicitly assigned to Owner are Contractor's responsibility. Perform additional quality-control activities required to verify that the Work complies with requirements, whether specified or not.
1. Where services are indicated as Contractor's responsibility, engage a qualified testing agency to perform these quality-control services.
 - a. Contractor shall not employ same entity engaged by Owner, unless agreed to in writing by Owner.
 2. Notify testing agencies at least 120 hours in advance of time when Work that requires testing or inspecting will be performed.
 3. Where quality-control services are indicated as Contractor's responsibility, submit a certified written report, in duplicate, of each quality-control service.
 4. Testing and inspecting requested by Contractor and not required by the Contract Documents are Contractor's responsibility.
 5. Submit additional copies of each written report directly to authorities having jurisdiction, when they so direct.
- C. Manufacturer's Field Services: Where indicated, engage a manufacturer's representative to observe and inspect the Work. Manufacturer's representative's services include examination of

**NISQUALLY STATE PARK
NEW FULL SERVICE PARK - PHASE 2**

substrates and conditions, verification of materials, inspection of completed portions of the Work, and submittal of written reports.

- D. Retesting/Reinspecting: Regardless of whether original tests or inspections were Contractor's responsibility, provide quality-control services, including retesting and reinspecting, for construction that replaced Work that failed to comply with the Contract Documents.
- E. Testing Agency Responsibilities: Cooperate with Project Representative and Contractor in performance of duties. Provide qualified personnel to perform required tests and inspections.
 - 1. Notify Project Representative and Contractor promptly of irregularities or deficiencies observed in the Work during performance of its services.
 - 2. Determine the location from which test samples will be taken and in which in-situ tests are conducted.
 - 3. Conduct and interpret tests and inspections and state in each report whether tested and inspected work complies with or deviates from requirements.
 - 4. Submit a certified written report, in duplicate, of each test, inspection, and similar quality-control service through Contractor.
 - 5. Do not release, revoke, alter, or increase the Contract Document requirements or approve or accept any portion of the Work.
 - 6. Do not perform any duties of Contractor.
- F. Associated Services: Cooperate with agencies performing required tests, inspections, and similar quality-control services, and provide reasonable auxiliary services as requested. Notify agency sufficiently in advance of operations to permit assignment of personnel. Provide the following:
 - 1. Access to the Work.
 - 2. Incidental labor and facilities necessary to facilitate tests and inspections.
 - 3. Adequate quantities of representative samples of materials that require testing and inspecting. Assist agency in obtaining samples.
 - 4. Delivery of samples to testing agencies.
 - 5. Preliminary design mix proposed for use for material mixes that require control by testing agency.
 - 6. Security and protection for samples and for testing and inspecting equipment at Project site.
- G. Coordination: Coordinate sequence of activities to accommodate required quality-assurance and -control services with a minimum of delay and to avoid necessity of removing and replacing construction to accommodate testing and inspecting.
 - 1. Schedule times for tests, inspections, obtaining samples, and similar activities.

1.9 SPECIAL TESTS AND INSPECTIONS

- A. Special Tests and Inspections: Conducted by a qualified testing agency as required by Authorities Having Jurisdiction, as indicated in individual Specification Sections and as follows:

**NISQUALLY STATE PARK
NEW FULL SERVICE PARK - PHASE 2**

1. Verifying that manufacturer maintains detailed fabrication and quality-control procedures and reviews the completeness and adequacy of those procedures to perform the Work.
2. Notifying Project Representative and Contractor promptly of irregularities and deficiencies observed in the Work during performance of its services.
3. Submitting a certified written report of each test, inspection, and similar quality-control service to Project Representative with copy to Contractor and to Authorities Having Jurisdiction.
4. Submitting a final report of special tests and inspections at Substantial Completion, which includes a list of unresolved deficiencies.
5. Interpreting tests and inspections and stating in each report whether tested and inspected work complies with or deviates from the Contract Documents.
6. Retesting and reinspecting corrected work.

PART 2 - PRODUCTS (NOT USED)

PART 3 - EXECUTION

3.1 TEST AND INSPECTION LOG

- A. Test and Inspection Log: Prepare a record of tests and inspections. Include the following:
 1. Date test or inspection was conducted.
 2. Description of the Work tested or inspected.
 3. Date test or inspection results were transmitted to Project Representative.
 4. Identification of testing agency or special inspector conducting test or inspection.
- B. Maintain log at Project site. Post changes and revisions as they occur. Provide access to test and inspection log for Project Representative's and Commissioning Authority's, during normal working hours.

3.2 REPAIR AND PROTECTION

- A. General: On completion of testing, inspecting, sample taking, and similar services, repair damaged construction and restore substrates and finishes.
 1. Provide materials and comply with installation requirements specified in other Specification Sections or matching existing substrates and finishes. Restore patched areas and extend restoration into adjoining areas with durable seams that are as invisible as possible.
- B. Protect construction exposed by or for quality-control service activities.
- C. Repair and protection are Contractor's responsibility, regardless of the assignment of responsibility for quality-control services.

END OF SECTION

**NISQUALLY STATE PARK
NEW FULL SERVICE PARK – PHASE 2**

SECTION 014100 - REGULATORY REQUIREMENTS

PART 1 - GENERAL

1.1 PERMITS, CODES AND REGULATIONS

A. The following permits have been applied for (or are on file) and incorporated into the contract:

1. Shoreline Substantial Development
2. Conditional Use
3. 1001191 Site Development Permit
4. 1001198 Driveway Approach Permit
5. 1001200 Gate Permit
6. 1024101 Minor Improvements in Existing ROW Permit
7. 1008578 Staff Residence Building Permit
8. 1007540 Administration Building Permit
9. 1007562 Gate Plinths Building Permit
10. 1007569 Welcome Figure Footing Building Permit
11. 1007560 6-Sided Kiosk @ Admin. Building Permit
12. 1007572 6-Sided Kiosk @ Trailhead Building Permit
13. 10075732-Sided Kiosk Building Permit
14. 1007582 CXT Vault Toilet @ Bus Parking Building Permit
15. 1007575 CXT Vault Toilet @ Trailhead Building Permit
16. 1007577 Boardwalk & Overlooks Building Permit

B. Conform with the requirements of listed permits and additional or other applicable permits, codes, and regulations as may govern Work.

C. Obtain and pay fees for licenses, permits, inspections, and approvals required by laws, ordinances, and rules of appropriate governing or approving agencies necessary for proper completion of Work (other than those listed under item 1.1A. above and Special Inspections called for by the International Building Code).

D. Conform with current applicable codes, regulations and standards, which is the minimum standard of quality for material and workmanship. Provide labor, materials, and equipment necessary for compliance with code requirements or interpretations, although not specifically detailed in the Drawings or specifications. Be familiar with applicable codes and standards prior to bidding.

E. Process through Project Representative, requests to extend, modify, revise, or renew any of the permits (listed in 1.1A above). Furnish requests in writing and include a narrative description and adequate Drawings to clearly describe and depict proposed action. Do not contact regulatory agency with requests for permit extensions, modifications, revisions, or renewals without the prior written consent of Project Representative.

**NISQUALLY STATE PARK
NEW FULL SERVICE PARK – PHASE 2**

1.2 VARIATIONS WITH CODES, REGULATIONS AND STANDARDS

- A. Nothing in the drawings and specifications permits Work not conforming to codes, permits or regulations. Promptly submit written notice to Project Representative of observed variations or discrepancies between the Contract documents and governing codes and regulations.
- B. Appropriate modifications to the Contract documents will be made by Change Order to incorporate changes to Work resulting from code and/or regulatory requirements. Contractor assumes responsibility for Work contrary to such requirements if Work proceeds without notice.
- C. Contractor is not relieved from complying with requirements of Contract documents which may exceed, but not conflict with requirements of governing codes.

1.3 COORDINATION WITH REGULATORY AGENCIES

- A. Coordinate Work with appropriate governing or regulating authorities and agencies.
- B. Provide advance notification to proper officials of Project schedule and schedule revisions throughout Project duration, in order to allow proper scheduling of inspection visits at proper stages of Work completion.
- C. Regulation coordination is in addition to inspections conducted by Project Representative. Notify Project Representative of scheduled inspections involving outside regulating officials, to allow Project Representative to be present for inspections.

PART 2 - PRODUCTS (NOT USED)

PART 3 - EXECUTION (NOT USED)

END OF SECTION

**NISQUALLY STATE PARK
NEW FULL SERVICE PARK - PHASE 2**

SECTION 014200 – REFERENCES

PART 1 - GENERAL

1.1 DEFINITIONS

- A. General: Basic Contract definitions are included in the General Conditions of the Contract.
- B. "Approved": When used to convey Project Representative's action on Contractor's submittals, applications, and requests, "approved" is limited to Project Representative's duties and responsibilities as stated in the General Conditions of the Contract.
- C. "Directed": A command or instruction by Project Representative. Other terms including "requested," "authorized," "selected," "required," and "permitted" have the same meaning as "directed."
- D. "Indicated": Requirements expressed by graphic representations or in written form on Drawings, in Specifications, and in other Contract Documents. Other terms including "shown," "noted," "scheduled," and "specified" have the same meaning as "indicated."
- E. "Regulations": Laws, ordinances, statutes, and lawful orders issued by authorities having jurisdiction, and rules, conventions, and agreements within the construction industry that control performance of the Work.
- F. "Furnish": Supply and deliver to Project site, ready for unloading, unpacking, assembly, installation, and similar operations.
- G. "Install": Operations at Project site including unloading, temporarily storing, unpacking, assembling, erecting, placing, anchoring, applying, working to dimension, finishing, curing, protecting, cleaning, and similar operations.
- H. "Provide": Furnish and install, complete and ready for the intended use.
- I. Project Representative and Owners Representative are interchangeable terms.
- J. "Owner"; Washington State Parks & Recreation Commission staff or the designated representative.
- K. "Owner Furnished/Contractor Installed": Owner will furnish a finished product to the Contractor and Contractor is responsible for securely storing the Owner furnished product till the Contractor is prepared to install it. The Contractor is responsible for installation of the finished products.
- L. "Owner's Representative (O.R.), "Project Engineer", "Project Architect", "Engineer", "Landscape Architect", and "Architect" are interchangeable terms.
- M. "As-built Drawings": Drawings done by the Contractor in the field showing changes to the Work.

**NISQUALLY STATE PARK
NEW FULL SERVICE PARK - PHASE 2**

N. “Record Drawings”: Drawings prepared based on the information on the As-built Drawings.

1.2 GENERAL

A. Applicable standards of the construction industry have the same force and effect (and are made a part of the Contract Documents by reference) as if directly copied or bound herein.

1.3 PUBLICATION DATES

A. Where compliance with an industry standard is required, comply with the standard in effect on Bid Date.

1.4 ABBREVIATIONS AND NAMES

A. The following acronyms or abbreviations, referenced in the Contract documents, are defined to mean the associated name. Applicable standards include, but are not limited to the following:

1.	AASHTO	American Association of State Highway & Transportation Officials
2.	ACI	American Concrete Institute
3.	AGA	American Gas Association
4.	AI	Asphalt Institute
5.	AIA	American Institute of Architects (The)
6.	AISC	American Institute of Steel Construction, Inc.
7.	AISI	American Iron and Steel Institute
8.	AITC	American Institute of Timber Construction
9.	ANSI	American National Standards Institute
10.	APA	Engineered Wood Association (The)
11.	APWA	American Public Works Association
12.	ASME	American Society of Mechanical Engineers
13.	ASTM	American Society for Testing and Materials International
14.	AWPA	American Wood Protection Association
15.	AWS	American Welding Society
16.	AWWA	American Water Works Association
17.	CRSI	Concrete Reinforcing Steel Institute
18.	EPA	Environmental Protection Agency
19.	HPVA	Hardwood Plywood and Veneer Association
20.	IBC	International Building Code
21.	IEEE	Institute of Electrical & Electronics Engineers, Inc. (The)
22.	IES	Illuminating Engineering Society of North America
23.	LPI	Lighting Protection Institute
24.	MCAA	Mechanical Contractors Association of America, Inc.
25.	NIST	National Institute of Standards and Technology
26.	NCMA	National Concrete Masonry Association
27.	NEC	National Electrical Code
28.	NECA	National Electrical Contractors Association, Inc.
29.	NFPA	National Fire Protection Association
30.	NHLA	National Hardwood Lumber Association

**NISQUALLY STATE PARK
NEW FULL SERVICE PARK - PHASE 2**

31.	NSF	National Sanitation Foundation International
32.	OSHA	Occupational Safety & Health Administration
33.	PCA	Portland Cement Association, (The)
34.	SEPA	State Environmental Policy Act
35.	UL	Underwriters Laboratories, Inc.
36.	UPC	Uniform Plumbing Code
37.	WCLIB	West Coast Lumber Inspection Bureau (Grading Rules)
38.	WRI	Wire Reinforcement Institute
39.	WSDOE or ECY	Washington State Department of Ecology
40.	WSDOH or DOH	Washington State Department of Health
41.	WSDOT	Washington State Department of Transportation
42.	WSDOTSS	Washington State Department of Transportation Standard Specifications
43.	WSPRC	Washington State Parks and Recreation Commission
44.	WWPA	Western Wood Products Association (Grading Rules)

B. The following abbreviations, referenced in the Contract Documents, are defined as follows.

@	at
ABI	Alternate Bid Item
CLR	Clear
CONC.	Concrete
CONT.	Continuous
CSBC	Crushed Surfacing Base Course
CSTC	Crushed Surfacing Top Course
DIM	Dimension
EX.	Existing
ES	Equally Spaced
GALV.	Galvanized
GPM	Gallons Per Minute
HMA	Hot Mix Asphalt
MIN.	Minimum
O.C.	On Center
O.D.	Outside Diameter
PCC	Portland Cement Concrete
PSI	Pound per square inch
SS	Stainless Steel
TESC	Temporary Erosion & Sedimentation Control
TYP.	Typical
VERT.	Vertical
WSDOTSS	Washington State Department of Transportation Standard Specifications

PART 2 – PRODUCTS (NOT USED)

PART 3 – EXECUTION (NOT USED)

END OF SECTION

NISQUALLY STATE PARK
NEW FULL SERVICE PARK – PHASE 2

SECTION 014300 – INSPECTIONS & TESTS

PART 1 - GENERAL

1.1 SCOPE

- A. When testing is required, special inspection and laboratory services obtained by the Owner are solely an assurance that Contract Document provisions are met. Results of Owner-procured tests and inspections will be submitted to the Contractor. In no way is this to be construed as relieving the Contractor of his/her obligations to provide materials and workmanship in accordance with the specifications.

1.2 COSTS

- A. Unless otherwise specified in the Contract Documents, the Owner will select and pay for all initial services of the testing laboratory. When initial tests indicate non-compliance with the Contract Document, the costs of subsequent tests associated with that non-compliance will be deducted by the Owner from the Contract Sum. All subsequent testing will be performed by the same testing laboratory and the costs deducted from the Contract Sum.

1.3 CODE COMPLIANCE TESTING

- A. Inspections and tests required by codes, ordinances or by a plan approval authority shall be coordinated by the Contractor and paid for by the Owner for the initial inspection. Any inspections or tests associated with non-compliance will be deducted by the Owner from the Contract Sum.

1.4 SUBMITTALS

- A. Promptly process and distribute all required copies of test reports and related instructions.

1.5 DUTIES OF INSPECTORS AND TESTING SERVICES

- A. General: Inspection and testing services may be engaged by the Owner for the checking and testing of the following phases of the Work.
- B. Site Work and Utilities:
 - 1. Compaction of Fill: Test fill after compaction for required densities.
 - 2. Composition of Fill: Test prior to import for compliance with granular size specification.
 - 3. Earthwork: Verify bearing capacity of all excavating bearing surfaces.
 - 4. Subgrade: Test subgrade for compaction and planarity.
- C. Concrete Work:

NISQUALLY STATE PARK
NEW FULL SERVICE PARK – PHASE 2

1. Standard Reinforcing Steel and Embedded Items: Check reinforcing bars and fabric in place prior to any placing of concrete. Verify condition of surfaces for bond integrity with concrete, locations and sizes of all items imbedded, and anchorage for prevention of displacement.
2. Structural Concrete: Make tests of water/cement ratio by weight. Check batch consistency. Make slump tests for each pour per ASTM C143. Furnish continuous inspection during placement, form removal, repair and patching, and curing of concrete. Contractor shall provide at least three test cylinders of each strength of concrete for each 150 cubic yards placed, or for each day's pour, whichever is greater.

1.6 CONTRACTOR'S RESPONSIBILITY

- A. Schedule: Layout and Plan Work so that parts of the Work requiring special inspection and laboratory testing are available at appropriate time. Contractor to coordinate inspections with inspection agency.
- B. Notification: Notify Owner at least forty-eight (48) hours before inspection will be required.
- C. Access: Allow inspection and testing personnel free access to the parts of the Work for which they have evaluation responsibility. Furnish records and drawings or data as may be required by testing and inspection personnel for the performance of their duties.
- D. Defective Work: Remove and replace or bring into conformance with the Contract Documents any materials and work found defective by testing and inspection personnel at no additional cost to the Owner.
- E. Adherence to Schedule: When the testing laboratory is ready to test according to the determined schedule but is prevented from testing or taking specimens due to incompleteness of the work, all extra costs attributable to the delay may be charged to the Contractor.

1.7 SPECIMENS

- A. All specimens and samples for testing, unless otherwise provided in these Contract Documents, will be taken by the testing laboratory. All sampling equipment and personnel will be provided by the testing laboratory. All deliveries of specimens and samples to the testing laboratory will be performed by the testing laboratory.

END OF SECTION

**NISQUALLY STATE PARK
NEW FULL SERVICE PARK – PHASE 2**

SECTION 015000 – TEMPORARY FACILITIES AND CONTROLS

PART 1 - GENERAL

1.1 SUMMARY

- A. Provide Temporary Facilities to facilitate the proper implementation of the Contract. Provide Controls for the planning, installing, inspecting, maintaining, and removing Best Management Practices (BMP) to prevent pollution of air and water.

1.2 PROTECTION OF PROPERTY AND EXISTING FACILITIES

- A. Provide protections necessary to prevent damage to park property and facilities.
- B. Only rubber-tired equipment are permitted to operate on paved park roads.
- C. Protect existing trees and other vegetation indicated to remain in place against cutting, breaking or skinning of roots, skinning and bruising of bark, or smothering of trees by stockpiling materials within dripline. Provide necessary temporary guards to protect trees and vegetation to remain in place.
- D. Make every effort to minimize damage and cutting major tree roots during excavation operations. Provide protection for larger tree roots exposed or cut during excavation operations.

1.3 ENVIRONMENTAL PROTECTIONS

- A. Scope:
 - 1. Provide labor, materials, equipment and perform Work required for protection of environment during and as a result of construction operations under contract.
- B. Applicable Regulations:
 - 1. Comply with applicable federal, state and local laws and regulations concerning environmental pollution control and abatement, and specific requirements elsewhere in specifications and drawings to prevent and provide for control of environmental pollution.
- C. Protection of Land Resources:
 - 1. Give special attention to the effect of Contractor's operations upon surroundings. Take special care to maintain natural surroundings undamaged and conduct Work in compliance with following requirements:
 - a. When Work is completed, remove storage and other Contractor buildings and facilities, and sites restored to a neat and presentable condition appropriate to surrounding landscape, unless otherwise specified. Remove debris resulting from Contractor's operation.

**NISQUALLY STATE PARK
NEW FULL SERVICE PARK – PHASE 2**

- b. Store petroleum products, industrial chemicals and similar toxic or volatile materials in durable containers approved by the Authority Having Jurisdiction and located in areas where accidental spillage will not enter water. Store substantial quantities of materials in an area surrounded by containment dikes of sufficient capacity to contain an aggregate capacity of tanks.

D. Protection and Restoration of Property:

1. Preserve public and private property, monuments, power and telephone lines, other utilities, prevention of damage to natural environment, etc., insofar as they may be endangered by Work.
2. When or where any direct or indirect damage or injury is done to public or private property by or on account of any act, omission, neglect or misconduct in execution of Work, or in consequence of non-execution of Contractor, restore, or have restored at Contractor's expense, such property to a condition similar and equal to that existing before such damage or injury was done, by repairing, rebuilding, or otherwise restoring same, or make good damage or injury in some other manner acceptable to Project Representative.

E. Protection of Water Resources:

1. Perform Work not to create conditions injurious to fish or to their habitat, or which would make water unsuitable for private, municipal, or industrial use.
2. Take special measures to prevent chemicals, fuels, oils, grease, bituminous materials, waste washings, herbicides, insecticides, lime, wet concrete, cement, silt or organic or other deleterious material from entering waterways.
3. Dispose of offsite, in a lawful manner conforming to applicable local, state and federal laws wastes, effluents, trash, garbage, oil, grease, chemicals, cement, bitumen, etc., petroleum, and chemical products or wastes containing such products. Furnish Owner with documentation showing compliance with this requirement.
4. Conform to applicable local, state and federal laws for disposal of effluents. Dispose of waters used to wash down equipment in a manner to prevent their entry into a waterway. If waste material is dumped in unauthorized areas, remove material and restore area to condition of adjacent, undisturbed area. If necessary, excavate contaminated ground and disposed of as directed by Project Representative and replace with suitable compacted fill material with surface restored to original condition.

F. Dust Control:

1. Dust control is required on roads used by Contractor. Maintain excavations, embankments, stockpiles, roads, plant sites, waste areas, borrow areas and other Work areas within or without the Project boundaries free from dust which would cause a hazard or nuisance to others. Provide approved, temporary methods of stabilization consisting of sprinkling, chemical treatment, light bituminous treatment or equal methods to control dust. If sprinkling is used, sprinkling must be repeated at intervals to keep disturbed areas at least damp.

G. Temporary Water Pollution/Erosion Controls:

1. Provide for prevention, control and abatement of soil erosion and water pollution within the limits of Project, to prevent and/or minimize damage to adjacent bodies of water and Work itself.

**NISQUALLY STATE PARK
NEW FULL SERVICE PARK – PHASE 2**

2. Coordinate temporary soil erosion/water pollution control measures with permanent drainage and erosion control Work to ensure effective and continuous controls are maintained throughout Project life.
3. Develop a written spill prevention and response plan for construction activities adjacent to/and over any surface waters and/or wetlands. “Adjacent” means within 150’ as measured on a horizontal plane. Plan addresses:
 - a. Narrative description of the proposed construction methods, materials, and equipment to be used for Work
 - b. Assessment and listing of hazardous materials and/or potential contaminants that could be released during execution of Work
 - c. SDS sheets with cleanup instructions for potential contaminants
 - d. Spill response/cleanup materials and instructions for use
 - e. Procedures and precautions to prevent spills
 - f. Spill response training for on-site personnel, including the location of the containment and cleanup materials at site
 - g. Emergency notification in case of a spill or release. Park Manager and Project Representative must be included on the list of notified.
4. Comply with applicable codes and ordinances for spill prevention and response plan and submit a copy to Project Representative before commencing Work adjacent to or over any waters and/or wetlands.

H. Emergency Spill Response Notification

1. Under state law, Ecology must be notified when any amount of regulated waste or hazardous material that poses an imminent threat to life, health, or the environment is released to the air, land, or water, or whenever oil is spilled on land or to waters of the state. The spiller is always responsible for reporting a spill. Failure to report a spill in a timely manner may result in enforcement actions. If you are not responsible for a spill, making the initial notification does not make you liable. However, please consult with Ecology’s response team before attempting any type of response or cleanup. Also notify Park Manager and Project Representative.
2. If oil or hazardous materials are spilled to state waters, the spiller must notify both federal and state spill response agencies. The federal agency is the National Response Center at 1-800-424-8802. For state notification, call the Washington Emergency Management Division (EMD) at 1-800-258-5990 or 1-800-OILS-911 AND the appropriate Ecology regional office for your county (see numbers below). An Ecology spill responder will normally call reporting party back to gather more information. The agency will then determine its response actions. Also notify Park Manager and Project Representative.
3. Ecology Regional Spill Reporting Numbers:
 - a. Southwest Regional Office: (360) 407-6300 (Clallam, Clark, Cowlitz, Grays Harbor, Jefferson, Lewis, Mason, Pacific, Pierce, Skamania, Thurston, and Wahkiakum counties)
 - b. TDD: Washington Relay Service 711 or (800) 833-6388.

1.4 PARK TRAFFIC/PEDESTRIAN CONTROLS

**NISQUALLY STATE PARK
NEW FULL SERVICE PARK – PHASE 2**

- A. Properly warn the public of construction equipment and activities, open trenches, and/or other unsafe conditions by providing all necessary warning equipment. Equipment includes warning signs, barricades, fencing, flashing lights and traffic control personnel (flaggers).
- B. Conduct operations with the least possible obstruction and inconvenience to the public in accordance with appropriate Section(s) of the WSDOT "Standard Specifications".

1.5 PROTECTION OF WORK

- A. Protect Work, materials, and equipment against damage, weather conditions, or other hazards. Equipment, Work or materials found damaged or in other than new condition will be rejected by Project Representative.

1.6 REMOVAL AND REPLACEMENT OF STATE-OWNED ITEMS

- A. Should any state-owned items, such as signs, bumper blocks, or related items, interfere with the proper construction process, remove and reinstall such items to the satisfaction of Project Representative.

1.7 USE OF PARK SPACE

- A. Only in areas of park that Contract covers and only during active inclusive dates of Contract.
- B. Contractor vehicle and equipment parking only as designated by Project Representative.
- C. Contractor will be issued temporary parking passes for construction crew, vehicles and equipment, valid for the duration of the contract only.

1.8 ROADWAY CLOSURE

- A. Closure of the park is not in the best interest of the general public, only close roads being trenched while conduits, etc., are being installed, and immediately reopened for traffic. Supply necessary barricades, etc., to effectively prevent automotive traffic from entering upon any traveled way while trenches are open, unless other approved appropriate safety measures are taken.

1.9 UTILITIES

- A. Existing subsurface utilities on Project are represented on Contract Drawings to the best of the Commission's knowledge. It is Contractor's responsibility to verify existence of utilities and determine exact location and depth. Maintain use of utilities during construction through temporary connections or other measures suitable to Commission. No extra compensation will be made for removal, temporary connections, relocations, or replacement of utilities.

1.10 SERVICE OUTAGES

**NISQUALLY STATE PARK
NEW FULL SERVICE PARK – PHASE 2**

- A. Coordinate and schedule outages for, power, water, and sewer service connections/repairs with Park Manager, so as not to inconvenience park staff or public.

1.11 SANITARY FACILITIES

- A. Provide temporary toilets, wash facilities, and drinking water for use of construction personnel. Comply with requirements of Authorities Having Jurisdiction for type, number, location, operation, and maintenance of fixtures and facilities.
- B. Contractor to provide portable toilet facilities for the workers.
- C. Locate on site as directed by the Owner.
- D. Contractor responsible for keeping facility clean and in working order.

1.12 TEMPORARY ELECTRICITY

- A. The Contractor shall provide his own separate power source to complete the work under this Contract. Provide all temporary power, including pole or poles, transformer(s), with voltage and phasing as required for the construction purposes.
- B. Provide power outlets for construction operations, with branch wiring and distribution boxes. Provide flexible power cords as required.

1.13 TEMPORARY LIGHTING

- A. Not Required.

1.14 TEMPORARY HEAT

- A. Not Required.

1.15 TELEPHONE SERVICE

- A. Contractor to furnish construction site with cellular phone and the contact information of Contractor's supervisory personnel.

1.16 TEMPORARY WATER SERVICE

- A. Contractor shall provide their own temporary water service until Contract water improvements have been implemented.

**NISQUALLY STATE PARK
NEW FULL SERVICE PARK – PHASE 2**

1.17 BARRIERS

- A. Provide barriers to prevent unauthorized entry to construction areas, and to protect existing facilities from damage from construction operations and demolition.
- B. Provide protection for plant life designated to remain. Replace damaged plant life.
- C. Protect non-owned vehicular traffic, stored materials, site and structures from damage.
- D. Stake and flag with yellow construction tape the lines noted on the Drawings as the “Work Limits”. All work and equipment is to remain inside the work limits.

1.18 FENCING

- A. Provide temporary chain-link fencing, six (6)-foot high with lockable gate for all material and equipment to be stored on site.

1.19 WATER CONTROL

- A. Grade site to drain. Maintain excavations free of water. Provide, operate, and maintain pumping equipment.
- B. Protect site from puddle or running water. Provide water barriers as required to protect site from soil or erosion.

1.20 EXTERIOR ENCLOSURES

- A. Provide temporary weather-tight closure of exterior openings to accommodate acceptable working conditions and protection for Products, to allow for temporary heating and maintenance of required ambient temperatures identified in individual specification Section, and to prevent entry for unauthorized persons.
- B. Provide access doors with self-closing hardware and locks.

1.21 INTERIOR ENCLOSURES

- A. Not Required.

1.22 PROTECTION OF INSTALLED WORK

- A. Protect installed work and provide special protection where specified in individual sections.
- B. Provide temporary and removable protection for installed Work and Products.
- C. Control activity in immediate work areas to minimize damage.

**NISQUALLY STATE PARK
NEW FULL SERVICE PARK – PHASE 2**

1.23 SECURITY

- A. Provide security and facilities to protect Work and existing facilities from unauthorized entry, vandalism, or theft.

1.24 ACCESS ROADS

- A. Provide and maintain access to Phase 1 Maintenance Building, free of obstructions.
- B. Provide means of removing mud from vehicle wheels before entering roadways/streets.
- C. Designated existing on-site roads may be used for construction traffic.
- D. Do not obstruct Owner operations.

1.25 FIELD OFFICE

- A. A Field Office is required to be present on-site for the contract performance period. Field Office shall contain conference room sufficient for twelve attendees, internet hardwire or wireless connection, telephone and fax. Field Office shall be heated. Contractor will provide access and use of Field Office to Owner.

1.26 PARKING

- A. Contractor parking limited to the project staging area.

1.27 CONCRETE WASH BASIN

- A. Contractor shall provide Concrete Wash Basin of the size, design, and location approved by the Owner.

1.28 PROGRESS CLEANING

- A. Maintain areas free of waste materials, debris, and rubbish.
- B. Maintain site in a clean and orderly condition.
- C. Remove waste materials, debris, and rubbish from site daily and dispose off-site.

PART 2 - PRODUCTS (NOT USED)

PART 3 - EXECUTION (NOT USED)

END OF SECTION

NISQUALLY STATE PARK
NEW FULL SERVICE PARK – PHASE 2

SECTION 015100 – FIELD ENGINEERING

PART 1 - GENERAL

1.1 LAYOUT

- A. The Contractor shall provide all construction survey necessary to establish all alignment and grade stakes for the proper execution of this contract. The Contractor is responsible for maintaining all stakes and points or re-establishing stakes, monuments, lines, and grades which are lost or destroyed at Contractor's cost.

1.2 VERIFICATION

- A. The Contractor shall verify all measurements shown on the Drawings and shall consult the plans, drawings and specifications of Work. The Contractor shall notify Owner of any discrepancies in the contract documents prior to commencement of construction. Failure of Contractor to notify Owner of discrepancies will result the Contractor being responsible for any and all resolutions and remedies.

PART 2 - PRODUCTS (NOT USED)

PART 3 – EXECUTION (NOT USED)

END OF SECTION

**NISQUALLY STATE PARK
NEW FULL SERVICE PARK - PHASE 2**

SECTION 015526 – TRAFFIC CONTROL

PART 1 – GENERAL

1.1 RELATED REQUIREMENTS

- A. Section 015000 – Temporary Facilities and Controls

1.2 GENERAL

- A. Provide flaggers, signs, and other traffic control devices in accordance with the Washington State Department of Transportation (WSDOT) Current Edition, Standard Specifications for Road, Bridge, and Municipal Construction and the Manual on Uniform Traffic Control Devices (MUTCD). Erect and maintain construction signs, warning signs, detour signs, and other traffic control devices necessary to warn and protect the public from injury or damage as a result of the Contractor's operations that may occur on highways, roads, drives, streets, or sidewalks and walkways. Do no work on or adjacent to the above locations until necessary signs and traffic control devices are in place.
- B. These flaggers, signs, and other traffic control devices are for the safety of the public, the Contractor's employees, and Commission's personnel and to facilitate the movement of the traveling public. They may be used for the separation or merging of public and construction traffic when in accordance with a specific approved traffic control plan.
- C. Upon failure of the Contractor to immediately provide flaggers; erect, maintain, and remove signs; or provide, erect, maintain, and remove other traffic control devices, the Commission may, without further notice to the Contractor, shut down the Contractor's activity until adjacent traffic control is implemented.
- D. Providing adequate flaggers, signs, and other traffic control devices for the protection of the work and the public at all times, regardless of whether or not the flaggers, signs, and other traffic control devices are ordered by the Project Representative, furnished by the Commission, or paid for by the Commission or by any modifications made by the Contractor. The Contractor shall be liable for injuries and damages to persons and property suffered by reason of the Contractor's operations or any negligence in connection therewith.
- E. Lane closure or diversion: advise Project Representative a minimum of two calendar days prior to implementation.

1.3 CONFORMANCE TO ESTABLISHED STANDARDS

- A. Flagging, signs, and other traffic control devices: conform to the standards established in the latest edition of the WSDOT Standard Specifications for Road, Bridge, and Municipal Construction, to the WSDOT Traffic Control Plans 1 through 18 (TC1-19) as published by WSDOT at <https://www.wsdot.wa.gov/Design/Standards/PlanSheet/Work-Zone-Typical-TCPs.htm> and to the Manual on Uniform Traffic Control Devices (MUTCD).

**NISQUALLY STATE PARK
NEW FULL SERVICE PARK - PHASE 2**

1.4 SUBMITTALS

- A. Submit a temporary traffic control plan for Project Representative review.

PART 2 – PRODUCTS (NOT USED)

PART 3 – EXECUTION

3.1 CONSTRUCTION PARKING CONTROL

- A. Control vehicular parking to prevent interference with public traffic and parking, and access by emergency vehicles. Monitor parking of construction personnel's vehicles. Maintain vehicular access to and through parking areas. Prevent parking on or adjacent to access roads or in non-designated areas. Construction Parking shall occur within Staging Area.

END OF SECTION

**NISQUALLY STATE PARK
NEW FULL SERVICE PARK – PHASE 2**

SECTION 015639 - TEMPORARY TREE AND PLANT PROTECTION

PART 1 - GENERAL

1.1 SUMMARY

- A. This Section includes the administrative and procedural requirements for the protection of trees, shrubs, and plant material not designated for removal. Trees, shrubs, and plant material not designated for removal shall be left in place and protected from damage or injury during construction using full and adequate methods of protection in order to preserve these natural resources, ecological function, and aesthetic character of the park.

1.2 REFERENCES

A. Definitions

1. Arborist Qualifications: An Arborist approved of by the Project Representative or certified by the International Society of Arboriculture (ISA) or Association of Consulting Arborists (ASCA) and licensed in the jurisdiction where project is located.
2. Critical Root Zone (CRZ): The portion of the root system nearest the stem that is critical for the stability and vitality of the tree. The minimum CRZ is a circular area having a radius of one foot for each one inch of trunk diameter defined by measuring the trunk diameter at 4.5 feet above ground level. For example, a tree that has a diameter of 20 inches would have a CRZ with a radius of 20 feet from the base of the tree. This is a MINIMUM CRZ radius for healthy trees; the CRZ often extends beyond the dripline of the tree. A critical root zone defined by 2.5 feet radius for each 1-inch diameter is desirable for old growth, historic, and character trees as designated by the Project Representative.
3. Vegetation Protection Zone (VPZ): A defined area of any size within the project area where existing vegetation (trees, shrubs, or other plant material) is to be protected from construction impacts. The zone may be accomplished by physical barriers or other means (e.g., soil protection layers or treatments).
4. Soil Protection Zone (SPZ): A defined area of any size within the project area where sensitive native soils are to be protected from construction impacts. The zone may be accomplished by physical barriers or other means (e.g., soil protection layers, durable matting, or other treatments as specified by the Project Representative).
5. High Risk Tree: Any tree with a structural defect and/or disease that makes the tree highly prone to failure, and which has a target and may result in personal injury or property damage. A high risk tree is the same as an “Emergency Tree” as defined in WAC 352-28-005 (<https://apps.leg.wa.gov/wac/default.aspx?cite=352-28-005>)

B. Reference Standards

1. ANSI A300. Specifications for Tree, Shrub, and Other Woody Plant Management including Section 5: Management of Trees and Shrubs During Site Planning, Site Development, and Construction.
2. ANSI Z133-2012. Safety Requirements for Arboricultural Operations.

**NISQUALLY STATE PARK
NEW FULL SERVICE PARK – PHASE 2**

3. Council of Tree and Landscape Appraisers. (2020). Guide for Plant Appraisal, 10th ed. International Society of Arboriculture, Champaign, Illinois.

1.3 SUBMITTALS

- A. Tree Removal and Pruning Schedule: Written schedule from project Arborist detailing scope and extent of tree removals and pruning of trees to remain that interfere with or are affected by construction.
- B. Certification: From project Arborist, certifying that trees indicated to remain have been protected during construction according to recognized standards and that trees were promptly and properly treated and repaired when damaged.
- C. Maintenance Recommendations: From project Arborist, for care and protection of trees affected by construction during and after completing the Work.

1.4 QUALITY ASSURANCE

- A. Tree Pruning Standard: Comply with ANSI A300 (Part 1), "Tree, Shrub, and Other Woody Plant Maintenance--Standard Practices (Pruning)."
- B. Construction Management Standard: Comply with ANSI A300 (Part 5): Management of Trees and Shrubs During Site Planning, Site Development, and Construction
- C. Tree Planting: Comply with ANSI A300 (Part 6) Planting and Transplanting
- D. Tree Root Protection and Management: Comply with ANSI A300 (Part 8) - 2013 Root Management Standard

PART 2 - PRODUCTS

2.1 TREE PROTECTION MATERIALS

- A. Temporary Fencing
 1. Chain link fencing panels 6 feet tall by any length up to 14 feet. Panels must be braced and must be secured to stands and weighted per manufacturers specifications.
 2. Continuous molded safety mesh 36 inches wide with clear openings no more than 1-1/2 inches x 2 inches. Orange, 40 grams per square foot, high density polyethylene with U-V inhibitor suitable for above-grade use installed around the circumference of the CRZ.
 3. Posts five-foot steel heavy-duty "T" posts, 1-3/8 inches x 1-3/8 inches x 7/64 inches with steel anchor placed at 8' intervals at or beyond the CRZ.
 4. Nylon zip straps having a minimum breaking strength of 150 lbs.

**NISQUALLY STATE PARK
NEW FULL SERVICE PARK – PHASE 2**

2.2 SOIL AND ROOT PROTECTION

- A. Mulch: Ground, shredded bark, or wood and bark chips, or “hog fuel” free from deleterious materials. Or new straw mulch, free from weeds, weed seeds, and foreign materials.
- B. Landscape fabric: American Excelsior Stablenka 140, Celanese Mirafi 140, Propex 45-45, or approved equivalent geotextile.
- C. Filter Fabric: Manufacturer’s standard, nonwoven, pervious, geotextile fabric of polypropylene, nylon, or polyester fibers.
- D. Ground staples: 9 inches x 9 inches wire staples sufficient for holding landscape fabric or filter fabric in place for required time period.
- E. Ground protection mats: Construction mats or timber mats, as a temporary road surface of sufficient weight rating for the equipment being operated in the work area.

2.3 TREE TRUNK PROTECTION

- A. Where work has been approved to take place within the CRZ, tree trunk protection shall be installed vertically around tree trunk on all sides exposed to construction activity.
- B. Common wood 2 inches x 4 inches lumber, 8 feet long, without nails, other hardware, concrete residue, or other material that may be detrimental to plant health.
- C. Strapping sufficient to hold 2 x 4’s

PART 3 - EXECUTION

3.1 PLANNING AND NOTIFICATION

- A. Where existing trees and other vegetation are in the area of work, or where existing trees outside the area of work have a CRZ extending into the area of work, employ methods to minimize adverse impact to the existing trees (including limbs, stems, and roots), understory vegetation and their root systems, and soils. Where VPZ are designated by the Project Representative and/or in project plans, observe protection measures set forth herein. Notify the Project Representative of any construction work within the CRZ of trees at least two (2) working days before the scheduled activity.

3.2 PREPARATION

- A. Prior to Construction: Erect tree and plant protection prior to beginning any site work. Protect trees to remain against cutting, breaking, skinning, or compaction of roots; skinning or bruising of bark; breaking of branches and foliage. Review locations, fencing, and other markings of any VPZ and CRZ for trees within the construction area with the Project Representative.
- B. Tree Removal: Trees that are scheduled for removal as part of the project should be removed before construction to prevent hazards during construction.

**NISQUALLY STATE PARK
NEW FULL SERVICE PARK – PHASE 2**

- C. Material Storage: Do not store construction materials, debris, or excavated material inside critical root zones or vegetation protection zones.
- D. Vehicle and Foot Traffic: Designate access routes within construction area and limitations on equipment and vehicles. Designate parking on existing pavement or away from critical root zones of trees. Tree protection fencing will serve as an exclusion zone within the CRZ except for where plans stipulate work will take place within the CRZ.

3.3 CRITICAL ROOT ZONE AND VEGETATION PROTECTION ZONE DESIGNATION

- A. Temporary Fencing: Install temporary fencing around CRZ, VPZ, or SPZ of either chain link or plastic mesh as indicated by Project Representative. Maintain temporary fence during construction and remove only when construction is complete.
 - 1. For plastic mesh, line posts space at eight feet maximum. Set posts vertically to minimum 18 inches depth. Posts may be driven provided method of driving does not damage posts. Ensure that posts do not damage tree roots.
 - 2. Where plastic fence is used, secure plastic fencing to posts with nylon zip-straps, minimum three per post. Draw fence material tight and vertical. Where chain link panels are used join panels with manufacturers clamps that require tool removal.
 - 3. With Project Representative's approval, sections of tree protection fencing may be removed temporarily to allow approved short-term construction activities. Reinstall fencing immediately when construction operations permit.
- B. Tree Trunk Protection: Where required tree trunks shall be protected by placing 2 x 4 lumber around the trunk, spaced so that strapping will not come in contact with the tree bark and lumber does not damage branches. Use strapping to hold lumber in place. Secure straps without nailing into or otherwise damaging tree bark.

3.4 SOIL COMPACTION, LOSS, AND DAMAGE WITHIN THE CRITICAL ROOT ZONE

- A. Protection against soil compaction within the CRZ may include but will not be limited to the following methods:
 - 1. Application of a minimum 6-inch thick layer of mulch (or wood chips salvaged from clearing and grubbing operations) within the CRZ. Replenish mulch as necessary to maintain a 6-inch depth. Do not place mulch within 6 inches of tree trunks. Where mulch is to be removed following project completion it should be underlaid with a porous geotextile.
 - 2. Ground protection mats, such as: timber or steel planking, construction mats, 1/2 inches thick CDX grade (or better) plywood, or brush for protection of surface roots and vegetation from equipment.
 - 3. Where equipment operating within the CRZ exceeds 12,000 lbs use a 6-inch layer of mulch overlaid with ground protection mats described above.
- B. Protection of soils against erosion and loss within the critical root zone of trees may require application of mulch, wood chips, ground protection mats, or landscape fabric at the request of the Project Representative.

**NISQUALLY STATE PARK
NEW FULL SERVICE PARK – PHASE 2**

- C. Noxious Materials: Protect soils from damage caused by runoff or spillage of noxious materials while operating, mixing, placing, or storing construction materials and equipment; this includes washout of concrete mixing vessels, dewatering operations, equipment cleanup, maintenance, and service; ponding, erosion, or excessive wetting may incur a Stop-Work order at the discretion of the Project Representative.
- 3.5 TRENCHING, DIGGING, TUNNELING, AND GRADING WITHIN THE CRITICAL ROOT ZONE:
- A. Disturbance to soils and impacts to roots within the CRZ may require any of, and will not be limited to, the following methods, practices, and restrictions:
1. Maintain existing grade within CRZ of trees unless otherwise directed.
 - a. Lowering grades (cutting): Where existing grade is above new finish grade shown around trees, carefully excavate within CRZ to new grade. Document roots exposed in this process with photographs to be shared with project Representative.
 - b. Raising grades (filling): Where existing grade is raised within the CRZ to greater than 4 inches above existing grade these roots shall be considered damaged by smothering. Methods to increase air exchange of tree roots within these areas may be required. Examples of such methods may include and will not be limited to:
 - 1) Application of a 6 inch or thicker layer of large clean aggregate (2 inches by 4 inches or larger) covered with landscape fabric below fill material to maintain large pore space.
 - 2) Selection of a fill material with high porosity and minimal compressibility, which may include mulch. Compaction will not be required except as required by structural load requirements, to limit soil compaction.
 2. Alternative excavation methods that minimize root damage may be required. These may include but are not limited to: hand digging, horizontal boring, use of an air excavation tool, or other methods as otherwise deemed necessary by the Project Representative.
- B. Only limited intrusions into tree CRZ zones will be allowed as shown on the plans and with the approval of the Project Representative. Where trenching for utilities or irrigation is required within CRZ's of trees the following may be required:
1. No cutting of roots greater than two inches diameter. Tunnel under or around roots by drilling, auger boring, air excavation, or digging by hand.
 2. Where necessary for installation, cut roots with sharp pruning instruments flush with the edge of the trench or tunnel; do not break or chop.
 3. Avoid hitting roots with heavy equipment. Roots that are ripped by equipment should be excavated by hand, photographed, kept moist with mulch or burlap layers, and inspected by the Project Representative.
 4. Pile excavated soil outside of the CRZ of residual trees and return area to original grade upon completion of work.
 5. Cover exposed roots with soil as soon as possible or at the end of each day; the soil compacted to the original firmness only; and, watered when conditions are dry.
 6. Tree root pruning or other tree root treatments may be required as directed by the Project Representative.

**NISQUALLY STATE PARK
NEW FULL SERVICE PARK – PHASE 2**

7. Root painting is not permitted.

3.6 STEM AND BRANCH PRUNING:

- A. Any unnecessary cutting, breaking, skinning, or bruising of bark; breaking of branches and foliage; damage or clearing of vegetation in the work area will not be permitted. Where permitted, stem and branch pruning must follow ANSI A300 Standards (including Part 1 and Part 5).
- B. Temporarily tie-up of low limbs is permitted where designated by the project representative.
- C. All final pruning cuts shall be made in branch tissue close to the trunk or parent limb, without cutting into the branch bark ridge or branch collar and without leaving a stub. Flush cuts to the tree trunk that remove the branch collar are unacceptable. Flush cuts result in a larger wound and expose trunk tissues to the possibility of decay.
- D. All significant tree pruning must have prior approval of Project Representative. An approved Arborist may be required, at the Contractor's expense, for extensive or technically challenging pruning activities. Such requirements will be made explicit to the Contractor prior to the start of work.
- E. Only proper branch pruning techniques will be accepted. Improperly pruned trees could be irreparably damaged and are subject to section 3.7 DAMAGE TO TREES AND TREE REPLACEMENT.

3.7 DAMAGE TO TREES AND TREE REPLACEMENT:

- A. Should any tree or vegetation designated to remain be damaged in the course of construction activities immediately notify the Project Representative for inspection and direction for remedy.
- B. Remedies for damage will, at the Owner's discretion, require removal and disposal of the damaged tree(s) and be one of the following, at the discretion of the Project Representative.
 - 1. Compensate the Owner in cash or as a credit to the contract for up to the full value of the damaged tree, as appraised by an ISA certified Arborist according to the latest edition of the "Guide for Plant Appraisal".
 - 2. Replace each damaged tree under 6 inches diameter at breast height measurement with one replacement tree of 1-3/4 inches caliper measure. Replace each damaged tree over 6 inches diameter at breast height measurement with one replacement tree of 1-3/4 inches caliper measure for each 6 inches of diameter at breast height measure of the damaged tree. The new trees may or may not be the same species, at the discretion of the Project Representative. Select nursery stock, plant, and maintain as specified in Section 1.4 QUALITY ASSURANCE.
 - 3. For identified old-growth trees specified to remain, the Project Representative may be provided alternative remediation requirements from Parks Stewardship staff above and beyond requirements of 3.7.B.1 and 3.7.B.2.
- C. Notify Project Representative in any case where construction called for in the contract documents cannot be completed without damage to trees identified to remain. Approval of the Project Representative is required prior to beginning construction described in the contract documents

**NISQUALLY STATE PARK
NEW FULL SERVICE PARK – PHASE 2**

that might damage a tree designated to remain. Any tree designated to remain which is damaged without Project Representative's written approval, even if damage is necessary to complete the work, will subject the Contractor to remedies described in section 3.7 B above.

END OF SECTION

**NISQUALLY STATE PARK
NEW FULL SERVICE PARK - PHASE 2**

SECTION 015713 – TEMPORARY EROSION AND SEDIMENTATION CONTROL

PART 1 - GENERAL

1.1 SCOPE OF WORK

- A. This Section includes Temporary Erosion and Sedimentation Control (TESC) measures including but not limited to silt fence, coir logs, catch-basin inlet protection, temporary storm conveyances, plastic sheeting, stabilized construction exits, and measures necessary to filter dewatering discharge prior to release from the site.
- B. This section includes the requirements for the Stormwater Pollution Prevention Plan (SWPPP) provided in accordance with the terms of the Washington Department of Ecology 2012 Stormwater Management Manual for Western Washington, regarding construction activities pertaining to this project.
- C. Protect all receiving waters from deleterious effects of construction.
- D. Provide the erosion control measures shown on the Plans and required herein and all additional measures that may be required by the Owner's Representative and the Contractor's means and methods of construction, as needed to control erosion and sediment at the construction site.
- E. Prevent violation of surface water quality, ground water quality, or sediment management standards.
- F. Erosion control measures shall be maintained throughout the course of construction and until all disturbed soil is stabilized in finished grades.
- G. This section includes the requirements for the Contractor's Spill Prevention Control and Countermeasures (SPCC) Plan.

1.2 RELATED WORK

- A. Coordinate related work specified in other parts of the Project Specifications, including, but not limited to the following:
 - 1. Clearing and Grubbing – 311100
 - 2. Earth Moving – 312000

1.3 QUALITY ASSURANCE

- A. The Contractor shall designate the TESC Lead person at the preconstruction meeting. The TESC Lead shall implement the TESC plan, the SWPPP, and the SPCC plan.
- B. TESC measures shown on the drawings are to be considered the minimum required measures necessary to initiate construction activities in typical weather conditions and with the Contractor providing all due care to protect the work from precipitation and runoff.

**NISQUALLY STATE PARK
NEW FULL SERVICE PARK - PHASE 2**

- C. Actual weather conditions, management of earthwork operations, and quality of installation of erosion control measures may cause the need for implementation of additional measures not specified on the drawings. The Contractor shall be responsible for all costs associated with implementation of additional TESC measures required by the Owner's Representative and as necessary to meet the requirements of the Clean Water Act, Department of Ecology, and City Standards.
- D. The Owner reserves the right to monitor water quality characteristics of all runoff and dewatering discharges. The Contractor is responsible for all fees, fines, and delays related to TESC, SWPPP, and SPCC plan non-compliance and other stormwater and dewatering system discharges.

1.4 CONSTRUCTION STORMWATER PERMIT TRANSFER

- A. Owner will transfer Washington State Department of Ecology's Construction Stormwater NPDES and State Waste Discharge General Permit to Contractor at the project's Pre-Construction Conference who be responsible for fulfilling all permit requirements and executing the permit's termination requirements.

1.5 SUBMITTALS

A. Monthly TESC Conditions Report

- 1. As a condition of payment, the Contractor shall submit monthly reports regarding TESC measures to the Owner's Representative that document the performance and any maintenance required of the TESC measures installed on-site.
- 2. This requirement shall be waived for months during which no rainfall event greater than 0.5 inches per day or no dewatering occurs.
- 3. Inspection reports shall include a record of:
 - a. Daily weather logs including observations of stormwater runoff from the site.
 - b. Test results of any water quality testing executed by the Contractor.
 - c. When, where, and how TESC measures were installed, removed, or modified.
 - d. Repairs to TESC measures that are made or required.
 - e. Observations of TESC measures effectiveness and proper placement.
 - f. Recommendations and implementation of improvements and additional TESC measures required as a result of the contractor's means and methods of prosecuting the work.
- 4. The reports shall be considered to be part of the SWPPP required by the Department of Ecology's Stormwater Management Manual. Copies of the TESC reports, this section of the specifications, and sheet 12 of the SWPPP shall be retained on site and shall be provided to DOE inspectors upon request.
- 5. The Contractor shall submit updated TESC Plans for each phase of the work. The updated phased TESC Plans shall include all TESC measures shown in the Contract Documents together with any enhancements or additional measures as required by the Owner's Representative or the Contractor's means and methods to meet the performance objectives of the Stormwater Pollution Prevention Plan (SWPPP).

B. Contractor's Spill Prevention Control and Countermeasures Plan (SPCC)

**NISQUALLY STATE PARK
NEW FULL SERVICE PARK - PHASE 2**

1. The Contractor shall submit a SPCC Plan prior to commencement of any construction activities.
2. The SPCC Plan shall include the following:
 - a. Construction phasing and identify potential spill sources at the site and the location of contaminant absorption and containment supplies.
 - b. Description of responsive actions in the event of a spill or release of contaminants and shall identify notification and reporting procedures.
 - c. Contractor management elements such as personnel responsibilities, project site security, site inspections, and training.
 - d. Description of measures the Contractor shall take to prevent the release or spread of the following:
3. All hazardous material found on site or encountered during construction.
4. All hazardous materials that the Contractor stores, uses, or generates on the construction site during construction activities.
5. Hazardous material as referred to within this specification is defined in RCW 70.105.010 under "hazardous substance".
6. A template for this plan can be found at the following web address:
<http://www.wsdot.wa.gov/eesc/environmental/programs/hazwqec/docs/modelplan.pdf>

PART 2 - PRODUCTS

2.1 GENERAL TESC MATERIALS

- A. All materials for BMPs shall conform to the requirements of the Sustainability Plan for the Washington State Parks and Recreation Commission.

2.2 SILT FENCE FABRIC

- A. Mirafi 100x, AMOCO 2130, or approved equal.

2.3 COIR LOG

- A. Provide Sediment Stop, 9" diameter x 50 ft long roll by North American Green (ACF West Inc. Geosynthetic Products, 15540 Woodinville-Redmond Road, Woodinville, WA 98072. Phone: (425) 415-6115) or approved equal.

2.4 CATCH BASIN FILTER

- A. Catch Basin Filter shall be StreamGuard Sediment Insert #3003, as procured from Bowhead Environmental and Safety, LLC, phone: (206) 905-4676, or approved equal.

2.5 PLASTIC COVERING

- A. Clear plastic (polyethylene) sheeting having a minimum thickness of 6 mil.

**NISQUALLY STATE PARK
NEW FULL SERVICE PARK - PHASE 2**

2.6 COMPOST

- A. Medium Compost as defined in WSDOT Standard Specifications Section 9-14.4(8) Compost.

2.7 TEMPORARY CONSTRUCTION ACCESS

- A. Woven polypropylene Geotextile, LINQ Industrial Fabrics GTF 200S, or approved equal.
- B. Quarry spalls as specified on Plans.
- C. Contractor may use existing concrete walk provided Commission approved structural protective measures are deployed.

PART 3 - EXECUTION

3.1 STORMWATER POLLUTION PREVENTION PLAN (SWPPP)

- A. The following 12 elements compose the narrative section of the SWPPP. See the contract plans for drawings of the project vicinity map, site map, conveyance systems, erosion and sediment control measures, and erosion and sediment control details.
 - 1. Element #1: Mark Clearing Limits.
 - a. Prior to beginning land disturbing activities, including clearing and grading, clearly mark all clearing limits and trees that are to be preserved within the construction area as shown on the drawings.
 - b. Temporary Security Fence shall be used to mark the clearing limits.
 - 2. Element #2: Establish Construction Access.
 - a. Limit construction vehicle access and exit to one route for each area of work or as shown on the Plans.
 - b. All exit points shall be stabilized with quarry spalls in conformance with the temporary construction access detail shown in the Plans.
 - c. Adjacent public roads shall be left in a clean and serviceable condition at the end of each day. Sediment shall be removed from roads by shoveling and street sweeping and shall be transported to a controlled sediment disposal area. Street washing will be allowed only after sediment is removed in this manner. Street washing shall only be performed with a truck equipped with vacuum water recovery equipment.
 - d. Construction access restoration shall be equal to or better than the preconstruction condition.
 - 3. Element #3: Install Sediment Controls.
 - a. The duff layer, native topsoil, and natural vegetation shall be retained in an undisturbed state to the maximum extent practicable, except where noted otherwise on the drawings.

**NISQUALLY STATE PARK
NEW FULL SERVICE PARK - PHASE 2**

- b. Sediment control measures shown on the drawings and additional measures required by the Contractor's means and methods shall be put in place prior to earthwork or site clearing operations or any other site disturbance within tributary areas of those controls.
4. Element #4: Stabilize Soils.
- a. From October 1 through April 30, all disturbed soils shall be stabilized with hydromulch, plastic sheeting, or other soil stabilization measures within 2 days of completion of grading. From May 1 to September 30, soils shall be stabilized within 7 days of completion of grading. This stabilization requirement applies to all soils on site outside active work areas, whether at final grade or not.
 - b. Soils shall be stabilized before a holiday or weekend if no earthwork is scheduled for that weekend or holiday and rain is forecasted.
 - c. Soil stockpiles must be covered with plastic sheeting and protected with sediment trapping measures, such as coir logs.
 - d. Remove all TESC measures as soon as practical after establishment of uniform grass growth or installation of other permanent stabilization measures. Repair any damage to stabilized surfaces after removal of TESC measures.
5. Element #5: Protect Slopes.
- a. Design, construct, and phase cut and fill slopes in a manner that will minimize erosion.
 - b. Do not clear and grub slopes greater than 4(horizontal):1(vertical) unless stabilization is scheduled for less than one week from completion of clearing and grubbing, or unless other temporary stabilization measures are put in place.
 - c. Consider soil type and its potential for erosion.
 - d. Reduce slope velocities on disturbed slopes by providing temporary barriers (such as coir logs) and by roughening the slope surface.
 - e. Stabilize soils on slopes, as specified in Element #4.
6. Element #6: Protect Drain Inlets.
- a. Storm drain inlets operable during construction and within 200' downstream of the project site shall be protected with catch basin filters so that stormwater runoff does not enter the conveyance system without first being filtered or treated to remove sediment. Catch basin filters in the roadway will be sediment filters.
 - b. Approach roads shall be kept clean. Sediment and street wash water shall not be allowed to enter storm drains without prior and adequate treatment.
 - c. Inlet protection devices should be cleaned or removed and replaced before six inches of sediment can accumulate.
7. Element #7: Stabilize Channels and Outlets.
- a. Temporary on-site conveyance channels required by the contractor's means and methods shall be designed, constructed, and stabilized to prevent erosion from the expected flow velocity of a 2-year, 24-hour frequency storm for the developed condition. In lieu of design, the Contractor may elect to line temporary channels with erosion control mat at contractor's expense.

**NISQUALLY STATE PARK
NEW FULL SERVICE PARK - PHASE 2**

8. Element #8: Control Pollutants.
 - a. This element is addressed in the Spill Prevention Control and Countermeasure (SPCC) Plan submitted by the Contractor. See Part 1.4.B of this Section for SPCC plan requirements.
9. Element #9: Control Dewatering.
 - a. The Contractor shall be responsible for meeting water quality standards for all dewatering discharge.
 - b. Highly turbid or contaminated dewatering water from construction equipment operation shall be handled separately from stormwater.
10. Element #10: Disposal options include:
 - a. Transport off site in a vehicle, such as a vacuum flush truck, for legal disposal in a manner that does not pollute state waters.
 - b. On-site treatment using approved chemical treatment.
 - c. Use of a sedimentation bag (Dirtbag or approved equal) with outfall to a ditch or swale for small volumes of localized dewatering.
11. Element #11: Maintain BMPs.
 - a. Inspect erosion control devices on a weekly basis and after each runoff event. Make necessary repairs and maintenance to ensure continued performance of erosion and sediment controls.
 - b. When sediment accumulation in sedimentation structures, other than inlet protection devices, has reached a point one-third depth of sediment structure or device, or if flow through the device is reduced by more than one-third capacity, the Contractor shall remove and replace disposable devices or clean and dispose of sediment.
 - c. Temporary erosion and sediment control BMPs shall be removed within 30 days after final site stabilization is achieved or after the temporary BMPs are no longer needed. Trapped sediment shall be removed or stabilized on site. Disturbed soils shall be permanently stabilized.
12. Element #12: Manage the Project.
 - a. Phasing of Construction
 - 1) Minimize disturbance and compaction of native soils except as necessary for the current phase of work.
 - 2) Stabilize areas immediately after work has been finished for that phase.
 - 3) Inspection and Monitoring
 - 4) An Erosion and Sediment Control lead shall be identified at the preconstruction meeting and shall be on-site or on-call at all times. Emergency contact information shall be kept on-site.
 - b. If inspection and/or water monitoring of site runoff reveals that the BMPs identified in the Construction SWPPP are inadequate, the Contractor shall immediately add BMPs to the SWPPP as necessary.

**NISQUALLY STATE PARK
NEW FULL SERVICE PARK - PHASE 2**

- c. The Construction SWPPP shall be retained on-site. The Contractor's TESC record of rainfall, TESC measures, and inspection shall become part of the SWPPP. The Construction SWPPP shall be modified by the contractor's TESC record whenever there is a significant change in the design, construction, operation, or maintenance of any BMP.

3.2 COMPOST FILTER BERM

- A. Install Compost Filter Berms in the dimensions and the alignment shown in the Plans or as needed. Berms shall be smooth lined, uniform surface and neat in appearance. Do not compact the compost during or after berm construction.

3.3 CLEANUP AND REMOVAL OF TESC MEASURES

- A. Completely remove all TESC measures, except compost filter berms, when directed by the Owner's Representative prior to Project Acceptance.
- B. Repair areas damaged by removal operation to match the conditions of non-damaged areas.

END OF SECTION

**NISQUALLY STATE PARK
NEW FULL SERVICE PARK – PHASE 2**

SECTION 016000 – PRODUCT REQUIREMENTS

PART 1 - GENERAL

1.1 OWNER FURNISHED/CONTRACTOR INSTALLED ITEMS

A. The Owner furnishes no items, except for following:

Owner Furnished Item	Approximate Delivery Date to Project Site
Administration Building Mural. Owner furnishes printed Fundermax Panels and installation accessories to the Contractor.	1/8/25
Administrative Building Lettering	10/2/24
Administration Building Entry Art (above door)	10/2/24
Welcome Figure	9/30/24
21 Custom ADA Benches	11/13/24
Gate Plinth Metal Baskets	9/18/24
Slide Gate Art	9/18/24
Overlook 2 Mosaic Digital Art File	5/1/24
Paddle Railing For Overlooks 2 & 3	5/1/24
Sculpture at Bench on Overlook 3 (Spindle Whorl)	8/5/24
Boardwalk Threshold Poles	8/5/24
6-Sided Carved Kiosk Peeler Poles (8 poles total, 4 poles per Kiosk)	10/2/24
24” Carved Wood Poles for Administration Building Entry	10/2/24
Toilet Roll Dispenser	10/2/24

1. Contractor shall make all arrangements for, and provide all fasteners and materials required to install the Owner Furnished items.

**NISQUALLY STATE PARK
NEW FULL SERVICE PARK – PHASE 2**

- B. The Owner furnishes no items except as listed in 1.1.A and the Borrow Pit from which Common Borrow A material will be sourced. There will be no unit cost for Common Borrow A material to the Contractor from the Owner.

1.2 IMPLIED/INCIDENTAL MATERIALS

- A. Contractor shall provide all minor materials required for proper Project completion. These minor materials, although not specifically mentioned or shown in Contract Documents, are part of materials to be provided by Contractor as a part of Contract and are considered incidental to the total cost of Project. No additional compensation is due to the Contractor for providing such items.

1.3 QUALITY OF MATERIALS

- A. Materials are to be new, free from defects, and of quality specified in the drawings and specifications.
- B. Select and provide materials to ensure satisfactory operation and rated life in prevailing environmental conditions were installed.
- C. Same make and quality throughout the entire job, for each type. Furnish materials of latest standard design products of manufacturers regularly engaged in their production.

1.4 SPECIFIED MATERIALS

- A. Drawings and specifications generally reference only one make and model for each item of material or equipment required. This is not intended to be restrictive but indicates the standard of quality, design, and features required.
- B. Specified product is the basis of design regarding physical size, strength, and performance. Products named indicate minimum acceptable product and are "or equal" unless noted otherwise.

1.5 SUBSTITUTIONS

- A. Substitutions for Cause: Submit requests for substitution immediately on discovery of need for change, but not later than 15 days prior to time required for preparation and review of related submittals.
 - 1. Conditions: Project Representative will consider Contractor's request for substitution when the following conditions are satisfied:
 - a. Requested substitution is consistent with Contract Documents and will produce indicated results.
 - b. Requested substitution provides sustainable design characteristics that specified product provided.
 - c. Requested substitution will not adversely affect Contractor's construction schedule.

**NISQUALLY STATE PARK
NEW FULL SERVICE PARK – PHASE 2**

- d. Requested substitution has received necessary approvals of Authorities Having Jurisdiction.
 - e. Requested substitution is compatible with other portions of Work.
 - f. Requested substitution has been coordinated with other portions of Work.
 - g. Requested substitution provides specified warranty.
 - h. If requested substitution involves more than one contractor, requested substitution has been coordinated with other portions of Work, is uniform and consistent, is compatible with other products, and is acceptable to all contractors involved.
- B. Substitutions for Convenience: Project Representative will consider requests for substitution if received within 40 days after the Notice to Proceed.
- 1. Conditions: Project Representative will consider Contractor's request for substitution when the following conditions are satisfied:
 - a. Requested substitution offers Owner a substantial advantage in cost, time, energy conservation, or other considerations, after deducting additional responsibilities Owner must assume. Owner's additional responsibilities may include compensation to Engineer for redesign and evaluation services, increased cost of other construction by Owner, and similar considerations.
 - b. Requested substitution does not require extensive revisions to Contract Documents.
 - c. Requested substitution is consistent with Contract Documents and will produce indicated results.
 - d. Requested substitution provides sustainable design characteristics that specified product provided.
 - e. Requested substitution will not adversely affect Contractor's construction schedule.
 - f. Requested substitution has received necessary approvals of Authorities Having Jurisdiction.
 - g. Requested substitution is compatible with other portions of Work.
 - h. Requested substitution has been coordinated with other portions of Work.
 - i. Requested substitution provides specified warranty.
 - j. If requested substitution involves more than one contractor, requested substitution has been coordinated with other portions of Work, is uniform and consistent, is compatible with other products, and is acceptable to all contractors involved.
- 1.6 SUBSTITUTION OF MATERIALS ("OR EQUAL")
- A. Proposed equipment to be considered "or equal" will necessitate written approval by the Engineer prior to substitution.
 - B. On requests for substitution of materials clearly define and describe proposed substitute.
 - C. Accompany requests by complete specifications, samples, records of performance, certified test reports, and such other information as the Engineer may request to evaluate the substitute product.
 - D. Contractor is responsible for a substitute item suiting the installation requirements and for additional costs incurred as a result of substitution.

**NISQUALLY STATE PARK
NEW FULL SERVICE PARK – PHASE 2**

- E. Final decisions regarding quality and suitability of proposed substitutions rests solely with Engineer and will be based on information submitted.

1.7 TECHNICAL DATA

- A. Technical data and information contained herein relies entirely on tests and ratings provided by manufacturers who are solely responsible for their accuracy. Project Representative, by use of this information in no way implies that Project Representative has tested or otherwise verified the results of published manufacturer's information.

1.8 DELIVERY, STORAGE AND HANDLING

- A. For Owner Furnished/Contractor Installed items listed in 1.1.A, the Owner will deliver these items to the Project Site at a date/time mutually agreed upon by the Owner and Contractor. Contractor shall provide the labor, equipment, materials, space, and everything needed to safely and properly unload all items. Once the delivery vehicle arrives at the Project Site, Contractor and Owner shall inspect Owner Furnished items and record the condition of all items. Thereinafter Contractor accepts all responsibility for safely and securely unloading and storing all Owner Furnished items. Contractor accepts responsibility for replacing any and all damaged Owner Furnished items, at Contractor's sole costs, till Final Completion. Replacing items damaged while in Contractor's custody in part, or in whole, will solely be the decision of the Owner.
- B. Transport products by methods to avoid product damage. Only deliver products to the installation site that are undamaged and free from defects.
- C. Provide proper equipment and personnel to handle and transport materials/products to the Project sites safely and undamaged.
- D. Promptly inspect material to assure that products comply with Contract requirements, quantities are correct, and products are undamaged.
- E. Store and/or stockpile materials and products only in areas of the Project designated and approved by Owner prior to delivery.
- F. Arrange storage to provide easy access for inspections. Original product labels, certifications, stamps, etc. to be intact and readily visible for inspection purposes.

PART 2 - PRODUCTS (NOT USED)

PART 3 - EXECUTION (NOT USED)

END OF SECTION

**NISQUALLY STATE PARK
NEW FULL SERVICE PARK – PHASE 2**

SECTION 017329 – CUTTING AND PATCHING

PART 1 - GENERAL

1.1 SUMMARY

- A. This Section includes procedural requirements for cutting and patching.

1.2 DEFINITIONS

- A. Cutting: Removal of in-place construction necessary to permit installation or performance of other Work.
- B. Patching: Fitting and repair work required to restore surfaces to original conditions after installation of other Work.

1.3 SUBMITTALS

- A. Cutting and Patching Proposal: For work not clearly indicated as cutting and patching on the drawings or specifications, submit a proposal describing procedures at least seven (7) days before the time cutting and patching will be performed, requesting approval to proceed. Include the following information, as applicable:
1. Extent: Describe cutting and patching, show how they will be performed, and indicate why they cannot be avoided.
 2. Changes to In-Place Construction: Describe anticipated results. Include changes to structural elements and operating components as well as changes in building's appearance and other significant visual elements.
 3. Products: List products to be used and firms or entities that will perform the Work.
 4. Utility Services and Mechanical/Electrical Systems: List services/systems that cutting and patching procedures will disturb or affect. List services/systems that will be relocated and those that will be temporarily out of service. Indicate how long services/systems will be disrupted.
 5. Structural Elements: Where cutting and patching involve adding reinforcement to structural elements, submit details and engineering calculations showing integration of reinforcement with original structure.
 6. Roofing Elements: Where cutting and patching involve cutting and patching roofing. Submit product data and samples of roofing material to be used.
 7. Noise and Dust Protection Plan.
- B. Architect or Engineer's Approval: Obtain approval of cutting and patching proposal before cutting and patching. Approval does not waive right to later require removal and replacement of unsatisfactory work.

1.4 QUALITY ASSURANCE

**NISQUALLY STATE PARK
NEW FULL SERVICE PARK – PHASE 2**

- A. Structural Elements: Do not cut and patch structural elements in a manner that could change their load-carrying capacity, load-deflection ratio, or seismic bracing capacity.
 - B. Operational Elements: Do not cut and patch operating elements and related components in a manner that results in reducing their capacity to perform as intended or that results in increased maintenance or decreased operational life or safety. Operating elements include the following:
 - 1. Primary operational systems and equipment.
 - 2. Air or smoke barriers.
 - 3. Fire-suppression systems.
 - 4. Mechanical systems piping and ducts.
 - 5. Control systems.
 - 6. Communication systems.
 - 7. Conveying systems.
 - 8. Electrical wiring systems.
 - 9. Operating systems of special construction in Division 13 Sections
 - C. Miscellaneous Elements: Do not cut and patch miscellaneous elements or related components in a manner that could change their load-carrying capacity, that results in reducing their capacity to perform as intended, or that results in increased maintenance or decreased operational life or safety.
 - D. Visual Requirements: Do not cut and patch construction in a manner that results in visual evidence of cutting and patching. Do not cut and patch construction exposed on the exterior or in occupied spaces in a manner that would, in Architect's opinion, reduce the building's aesthetic qualities. Remove and replace construction that has been cut and patched in a visually unsatisfactory manner.
 - E. Cutting and Patching Conference: Before proceeding, meet at Project site with parties involved in cutting and patching, including mechanical and electrical trades. Review areas of potential interference and conflict. Coordinate procedures and resolve potential conflicts before proceeding.
- 1.5 WARRANTY
- A. Existing Warranties: Remove, replace, patch, and repair materials and surfaces cut or damaged during cutting and patching operations, by methods and with materials so as not to void existing warranties.

PART 2 - PRODUCTS

2.1 MATERIALS

- A. General: Comply with requirements specified in other Sections.
- B. In-Place Materials: Use materials identical to in-place materials. For exposed surfaces, use materials that visually match in-place adjacent surfaces to the fullest extent possible.

**NISQUALLY STATE PARK
NEW FULL SERVICE PARK – PHASE 2**

1. If identical materials are unavailable or cannot be used, use materials that, when installed, will match the visual and functional performance of in-place materials.

PART 3 - EXECUTION

3.1 EXAMINATION

- A. Examine surfaces to be cut and patched and conditions under which cutting and patching are to be performed.
 1. Compatibility: Before patching, verify compatibility with and suitability of substrates, including compatibility with in-place finishes or primers.
 2. Proceed with installation only after unsafe or unsatisfactory conditions have been corrected.

3.2 PREPARATION

- A. Temporary Support: Provide temporary support of Work to be cut.
- B. Protection:
 1. Protect in-place construction during cutting and patching to prevent damage. Provide protection from adverse weather conditions for portions of Project that might be exposed during cutting and patching operations.
 2. Take precautions required by regulations and Standard Specifications to protect personnel and property.
 3. Take all necessary precautions for temporary fire protection during welding and cutting.
 - a. Carefully mask or shield adjacent surfaces to prevent damage from heat or welding materials. Take particular care to prevent fires.
- C. Adjoining Areas: Avoid interference with use of adjoining areas or interruption of free passage to adjoining areas.
- D. required to be removed, relocated, or abandoned, bypass such services/systems before cutting to prevent interruption to occupied areas.

3.3 PERFORMANCE

- A. General: Employ skilled workers to perform cutting and patching. Proceed with cutting and patching at the earliest feasible time, and complete without delay.
 1. Cut in-place construction to provide for installation of other components or performance of other construction, and subsequently patch as required to restore surfaces to their original condition.
- B. Cutting: Cut in-place construction by sawing, drilling, breaking, chipping, grinding, and similar operations, including excavation, using methods least likely to damage elements retained or

**NISQUALLY STATE PARK
NEW FULL SERVICE PARK – PHASE 2**

adjoining construction. If possible, review proposed procedures with original Installer; comply with original Installer's written recommendations.

1. In general, use hand or small power tools designed for sawing and grinding, not hammering and chopping. Cut holes and slots as small as possible, neatly to size required, and with minimum disturbance of adjacent surfaces. Temporarily cover openings when not in use.
 2. Finished Surfaces: Cut or drill from the exposed or finished side into concealed surfaces.
 3. Concrete: Cut using a cutting machine, such as an abrasive saw or a diamond-core drill.
 4. Mechanical and Electrical Services: Cut off pipe or conduit in walls or partitions to be removed. Cap, valve, or plug and seal remaining portion of pipe or conduit to prevent entrance of moisture or other foreign matter after cutting. If a valve is used, provide access to the valve.
 5. Proceed with patching after construction operations requiring cutting are complete.
- C. Patching: Patch construction by filling, repairing, refinishing, closing up, and similar operations following performance of other Work. Patch with durable seams that are as invisible as possible.
1. Inspection: Where feasible, test and inspect patched areas after completion to demonstrate integrity of installation.
 2. Exposed Finishes: Restore exposed finishes of patched areas and extend finish restoration into retained adjoining construction in a manner that will eliminate evidence of patching and refinishing.
 - a. Clean piping, conduit, and similar features before applying paint or other finishing materials.
 - b. Restore damaged pipe covering to its original condition.
- D. Cleaning: Clean areas and spaces where cutting and patching are performed. Completely remove paint, mortar, oils, putty, and similar materials.

END OF SECTION

**NISQUALLY STATE PARK
NEW FULL SERVICE PARK - PHASE 2**

SECTION 017419 - CONSTRUCTION WASTE MANAGEMENT AND DISPOSAL

PART 1 - GENERAL

1.1 DEBRIS DISPOSAL

- A. No disposal site has been provided by the state for any debris or waste generated by or resulting from the specified Work, except for the Nisqually/Ohop Access Disposal Site. The Borrow Pit shall not be used for disposal of any organic and inorganic materials generated from on, or off site sources. The Nisqually/Ohop Access Disposal Site is the only Disposal Site within Nisqually State Park that can be used during Phase 2 Construction.
- B. The Nisqually/Ohop Access Disposal Site is provided to dispose of mineral (soil), organic, and boulders in the manner defined in the Plans and Project Manual. All organic material placed in the Nisqually/Ohop Access Disposal Site shall be chipped/mulched and placed at the bottom of the Disposal Site prior to the placement of any mineral/soil as the next layer. No construction debris and trash or any human made materials other than chipped/mulched organic material, soil, and boulders shall be placed in the Nisqually/Ohop Access Disposal Site.
- C. All waste and debris removed from the worksite and not specified for reuse becomes the responsibility of the Contractor and disposed of off the park property in areas authorized by the applicable county and/or state agencies and in accordance with current rules and regulations governing the disposal of solid waste. All disposal fees and sundry charges are paid by the Contractor and are incidental to the contract.
- D. Tree limbs, branches, brush, and other small organic debris generated by the Work shall be chipped into mulch material and dispersed over specified areas of the Project. Only those areas in park specifically designated are to be used for these chipped/mulched materials may be disposed of in those areas which are shown on the Plans.
- E. Burning will not be permitted on this Project.

1.2 DAMAGE TO FACILITIES, ROADS, VEGETATION OR PROPERTY

- A. During the course of construction, should any park facility be damaged by the Contractor's actions, operations or neglect, repair any such damages to their original condition, as acceptable to the Engineer, at no cost to the Commission.
- B. Repair, restore or replace any park and County roads, vegetation or property damaged by the Contractor to the original condition at the time construction began. Repair or replace trees and vegetation indicated to remain, which has been damaged by construction operations, in a manner acceptable to the Engineer.

**NISQUALLY STATE PARK
NEW FULL SERVICE PARK - PHASE 2**

1.3 PROGRESS CLEANING

- A. Remove rubbish and debris from park property daily unless otherwise directed so as not to allow accumulation. Store materials that cannot be removed daily only in areas specified by the Engineer.
- B. Maintain worksites in a neat and orderly condition at all times.
- C. All cleanup operations are incidental to the Contract and no extra compensation will be made.

1.4 FINAL CLEAN-UP

- A. Clean up the entire construction site and all grounds occupied by the Contractor in connection with the Work. Upon completion of the Work and prior to final inspection and acceptance,
- B. Fine graded, rake clean and smooth all worksites and disturbed areas. Remove from the park all rubbish, surplus and discarded materials, falsework, temporary structures, equipment and debris.
- C. Leave all phases of the Project clean and ready for public use prior to final acceptance.
- D. Inspect all materials and surfaces for damage, scratches, marring, untreated ends of sawcuts, etc. and repair to original or intended condition.
- E. Sweep all pavements and rooves clean of all debris.

PART 2 - PRODUCTS (NOT USED)

PART 3 - EXECUTION (NOT USED)

END OF SECTION

**NISQUALLY STATE PARK
NEW FULL SERVICE PARK - PHASE 2**

SECTION 017700- CLOSEOUT PROCEDURES

PART 1 - GENERAL

1.1 OPERATING AND MAINTENANCE (O&M) INSTRUCTION MANUAL

- A. Final payment will be held to no more than 95 percent completion percentage until receipt of the O & M Instruction Manuals. Payment for Contract closeout item will be made after receipt and approval of the manuals by the Owner. Have O & M Instruction Manuals prepared before final payment. Lack of O & M Instruction Manuals will not be a cause for Contract extensions.
- B. Furnish three (3) complete sets of binders and one (1) electronic PDF containing the following data for each mechanical, pumping, electrical equipment, major hardware, and plumbing installation or provided on this Project:
 - 1. Installation instructions
 - 2. Operating instructions (start-up and shutdown)
 - 3. Maintenance instructions, including trouble shooting guide
 - 4. Electrical schematics
 - 5. Illustrated parts breakdown and code (if available)
 - 6. Parts list (complete)
 - 7. Technical manuals
 - 8. Provide a complete list of manufacturer's representatives sales offices, or suppliers of all major parts used on this Project, including their business address and telephone number, for the Park Manager's use when maintaining/repairing the system being constructed. Major parts are defined as other than miscellaneous plumbing, wire, piping fittings, etc.
 - 9. List of subcontractors contact information, and specific items of work performed by them.
 - 10. Tab binders and clearly mark all information contained.
- C. Affix to walls, panels, boxes or at other locations, the following data sealed in heavy plastic:
 - 1. Operating instructions (start-up and shutdown)
 - 2. Electrical schematics
- D. Operating instructions refer to designated parts of each particular installation as necessary and tag such parts with permanent markers as directed by Owner. This includes operational equipment.

1.2 AS-BUILTS DRAWINGS

- A. Before final acceptance of Project, furnish Owner "As-Built Drawings" which shows as-built locations and dimensions of major items constructed. Include locations and elevations of existing utilities encountered during excavation. Show location of pipes, manholes, buildings, structures, etc. by field measurements consisting of at least two (2) ties to permanent surface objects such as hydrants, buildings, etc.

**NISQUALLY STATE PARK
NEW FULL SERVICE PARK - PHASE 2**

- B. Final payment: No more than 95 percent until As-Builts Drawings received. Payment made after receipt and approval of drawings by Owner. Lack of As-Builts Drawings will not be a cause for contract extensions.

1.3 SPARE MATERIALS AND PARTS

- A. Before final acceptance, deliver spare materials, parts and other similar items storage locations specified by Owner.

1.4 CERTIFICATES AND PERMITS

- A. Submit signed original certificates of compliance and final approval from Authorities Having Jurisdiction.

1.5 OUTSTANDING DOCUMENTS

- A. Expedite and submit outstanding administrative documents including outstanding cost proposals, Change Orders, etc.

1.6 PRIOR OCCUPANCY

- A. Reference General Conditions.
- B. Commission has the right to occupy completed portions of Project prior to final acceptance, and such occupation is not an acceptance of Project. Prior to occupancy, Owner and Contractor mutually agree to a date for prior occupancy; the area to be occupied; that occupancy is commencing within the requirements of applicable codes and ordinances; that endorsements from insurance companies, as necessary to maintain full insurance of Project regardless of prior occupancy, have been obtained; and that other necessary provisions are completed.
- C. The Owner will inspect areas designated for prior occupancy and issue a letter of acceptance, or provide a list of deficiencies to be corrected, to Contractor. Correct deficiencies prior to date of occupancy.

1.7 SUBSTANTIAL COMPLETION

- A. Reference General Conditions.
- B. Notify Owner in writing a minimum of seven (7) days in advance of the scheduled date of completion. Owner will conduct a "pre-final" inspection and formulate a final punchlist of Work items to be completed prior to final inspection. Owner will establish the date of substantial completion based on pre-final inspection findings. Following this inspection, Owner will either issue notice of substantial completion or advise the Contractor of deficient items which must be corrected prior to issuance of substantial completion.

**NISQUALLY STATE PARK
NEW FULL SERVICE PARK - PHASE 2**

1.8 FINAL INSPECTION AND ACCEPTANCE

- A. Reference General Conditions.
- B. Notify Owner in writing when Work, including punchlist items, have been completed.
- C. Owner will schedule and conduct a final inspection to verify that outstanding Work items are complete.
- D. Owner will establish the date of final acceptance based on the results of final inspection. Complete/correct any items identified as outstanding during final inspection prior to final acceptance of Project.

1.9 FINAL CLEANUP

- A. Execute final Project cleanup prior to final inspection.
 - 1. Reference Section 017419 – Construction Waste Management and Disposal.

PART 2 - PRODUCTS (NOT USED)

PART 3 - EXECUTION (NOT USED)

END OF SECTION

NISQUALLY STATE PARK
NEW FULL SERVICE PARK – PHASE 2

SECTION 017839 – PROJECT AS-BUILT DRAWINGS

PART 1 - GENERAL

1.1 MAINTENANCE OF AS-BUILT DRAWINGS AND SAMPLES

- A. Maintain and store apart from documents used in construction:
 - 1. Contract Drawings annotated as work progresses.
 - 2. Project Manual and Specifications, as work progresses.
 - 3. Addenda.
 - 4. Change Orders and other Contract Modifications.
 - 5. Accepted Shop Drawings, product data, samples, etc.
 - 6. Field Test Reports.
 - 7. Current Construction Schedule.
- B. Maintain As-Built Drawings in clean orderly and legible condition. Do not use for construction purposes.
- C. Make documents available at all times for inspection by Owner.
- D. Label each document “PROJECT AS-BUILT” in neat large block letters.
- E. As-Built information concurrently with construction progress.
- F. Clearly mark all changes using an erasable colored pencil. Use different color pencil for overlapping changes.
- G. Indicate the following:
 - 1. Accurate measurements of underground utilities and services
 - 2. Note changes in directions and locations, slopes, and vertical and horizontal dimensions, as construction progresses.
 - 3. As-Built accurate locations of underground sleeves, piping, valves, etc.
 - 4. Show all detail and locations not on original drawings.
 - 5. Indicate field changes of dimension and detail.
 - 6. Indicate revisions to drawings with a “cloud” drawn around the revision and note revision and date of revision.

1.2 SUBMITTALS

- A. With each submittal of Payment Application and Certificate form, As-Built drawings, specifications, updated construction schedule and other documents will be made available for inspection by the Owner for complete and timely maintenance in accordance with the Contract Documents.
- B. At Contract Closeout and before final payment, deliver As-Built documents to the Owner.

NISQUALLY STATE PARK
NEW FULL SERVICE PARK – PHASE 2

1. One set As-Built Drawings legibly marked to As-Built actual construction.
 2. As-Built Drawings shall include the exact location of all underground and aboveground utilities, including the horizontal and vertical location of all service connections, valves, tees, and elbows. Upon completion a certified, PDF electronic copy of the As-Built Drawings shall be provided to the Owner.
- C. Request for Information: Contractor shall report, in writing, any errors, inconsistencies, omissions, or other questions regarding the work to the Owner in a timely fashion.
1. Form: The request for information shall include Date, related section and sheet number, detail number, as applicable, project name, contractor name, contract number, and the issue being discussed.
 2. The Owner shall be allowed seven calendar days to respond to Contractor generated Request for Information.
 3. Contractor shall maintain Request for Information Log and provide to Owner.

1.3 OPERATING, SERVICE AND MAINTENANCE MANUALS AND CONTRACTS

- A. Assemble Operating, Service and Maintenance Manuals and Contracts, executed by each of the respective Manufacturer, Suppliers and Subcontractors.
- B. Contractor and each Subcontractor shall submit a completed Vendor Contact List as attached to this section or in a similar format.
- C. Format
1. Assemble Operating, Service and Maintenance Manuals and Contracts into a three-ring, heavy-duty, vinyl, hardboard cover binder manual.
 2. On cover, imprint the "" Operating, Service and Maintenance Manuals and Contracts"; name of project, Owner, Landscape Architect; and date of Substantial Completion.
 3. On bound edge, imprint name of project and owner and date of substantial completion. Pages to be neat clean sheets, 8-1/2 by 11-inch maximum size or accordion foldouts to same size.
 4. Items to be identified with tabbed dividers showing name and number of appropriate specification sections.
 5. Arrange dividers and items in order they occur in specifications.

PART 2 - PRODUCTS (NOT USED)

PART 3 - EXECUTION (NOT USED)

END OF SECTION

**NISQUALLY STATE PARK
NEW FULL SERVICE PARK – PHASE 2**

SECTION 031000 – CONCRETE FORMING & ACCESSORIES

PART 1 - GENERAL

1.1 SECTION INCLUDES

- A. Provide all labor, materials and equipment required to complete the Work indicated on the drawings and specified herein.
- B. Provide labor, equipment, and materials necessary to construct formwork for cast-in-place concrete, with shoring, bracing, and anchorage if necessary.
- C. Provide openings for other work.
- D. Furnish and install all associated form accessories.
- E. Stripping and removal of formwork.
- F. Cleanup of formwork and adjacent elements, materials, and surfaces

1.2 RELATED REQUIREMENTS

- A. Section 032000 - Concrete Reinforcing.
- B. Section 033000 - Cast-In-Place Concrete.

1.3 REFERENCE STANDARDS

- A. ACI 117 - Specifications for Tolerances for Concrete Construction and Materials 2010 (Reapproved 2015).
- B. ACI 301 - Specifications for Structural Concrete 2016.
- C. ACI 318 - Building Code Requirements for Structural Concrete and Commentary; 2014
- D. ACI 347R - Guide to Formwork for Concrete 2014, with Errata (2017).
- E. PS 1 - Structural Plywood 2009.

1.4 SUBMITTALS

- A. Shop Drawings: Indicate pertinent dimensions, materials, bracing, and arrangement of joints and ties.

**NISQUALLY STATE PARK
NEW FULL SERVICE PARK – PHASE 2**

1.5 QUALITY ASSURANCE

- A. Perform Work in accordance with WSDOT Standard Specifications for Road, Bridge, and Municipal Construction, most current edition at time of Bid.
- B. Design, engineer, and construct formwork, shoring and bracing to conform to code requirements; resultant concrete to conform to required shape, line and dimension.
- C. Wet concrete shall be prevented from entering waters of the State. Forms for any concrete structure shall be constructed to prevent leaching of wet concrete. Impervious materials shall be placed over any exposed concrete not lined with forms which will come in contact with State waters. Forms and impervious materials shall remain in place until the concrete is cured (HPA Provision #28).
- D. Any form release agent used shall be a 100% natural, organic chemical release agent acceptable for use in sensitive aquatic environments. Refer to Products.

1.6 DELIVERY, STORAGE, AND HANDLING

- A. Deliver prefabricated forms and installation instructions in manufacturer's packaging.
- B. Store prefabricated forms off ground in ventilated and protected manner to prevent deterioration from moisture.
- C. Materials shall be immediately returned to the Staging Area after use. Any cleaning of forms or equipment shall be done in an approved area within the Staging Area.

PART 2 - PRODUCTS

2.1 FORMWORK - GENERAL

- A. Provide concrete forms, accessories, shoring, and bracing as required to accomplish cast-in-place concrete work.
- B. Design and construct concrete that complies with design with respect to shape, lines, and dimensions.
- C. Chamfer outside corners of beams and walls.
- D. Comply with applicable state and local codes with respect to design, fabrication, erection, and removal of formwork.
- E. Comply with relevant portions of ACI 301, ACI 318, ACI 347R, ACI 301, ACI 318, ACI 347R, ACI 301, ACI 318, and ACI 347R.

**NISQUALLY STATE PARK
NEW FULL SERVICE PARK – PHASE 2**

2.2 WOOD FORM MATERIALS - GENERAL

- A. Plywood: Douglas Fir species exterior type minimum 5/8" thick; medium density overlaid one side grade; sound undamaged sheets with clean, true edges and surfaces suitable for the required finish.
- B. Lumber forms shall be boards selected for straightness in both planes and having no surface defects which will prevent achieving the required finish.

2.3 FORMWORK ACCESSORIES

- A. Form Ties: Snap-off type, galvanized metal, fixed length, cone type, with waterproofing washer, free of defects that could leave holes larger than 1 inch (25 mm) in concrete surface.
- B. Form Release Agent: Capable of releasing forms from hardened concrete without staining or discoloring concrete or forming bugholes and other surface defects, compatible with concrete and form materials, and not requiring removal for satisfactory bonding of coatings to be applied.
- C. Form Release Agent: Colorless mineral oil that will not stain concrete, absorb moisture, impair natural bonding of concrete finish coatings, or affect color characteristics of concrete finish coatings.
- D. Corners: Chamfered, rigid plastic type; 3/4 x 3/4-inch (19 x 19 mm) size, unless shown otherwise; maximum possible lengths.
- E. Keyways shall be formed using wood or removable plastic or metal preformed units to sizes indicated.
- F. Nails, Spikes, Lag Bolts, Through Bolts, Anchorages: Sized as required, of sufficient strength and character to maintain formwork in place while placing concrete.
- G. Embedded Anchor Shapes, Plates, Angles and Bars: As shown on Drawings.
- H. Isolation/Expansion Joints: Furnish resilient bituminous type, Sternson Ltd. "Flexcell", Grace Construction Products "Fiber", Homosote Co. "Homex 300", Old North Mfg. Co., Inc. "Gray-Flex", or approved, non-extruding type, 1/2-inch thickness unless otherwise shown, of depth as required to bring top to within 1/4 inch of surface of slab.

PART 3 - EXECUTION

3.1 EXAMINATION

- A. Verify lines, levels and centers before proceeding with formwork. Ensure that dimensions agree with drawings.

3.2 EARTH FORMS

- A. Earth forms are not permitted.

**NISQUALLY STATE PARK
NEW FULL SERVICE PARK – PHASE 2**

3.3 ERECTION - FORMWORK - GENERAL

- A. Erect formwork, shoring and bracing to achieve design requirements, in accordance with requirements of ACI 347R.
- B. Provide bracing to ensure stability of formwork. Shore or strengthen formwork subject to overstressing by construction loads.
- C. Arrange and assemble formwork to permit dismantling and stripping. Do not damage concrete during stripping. Permit removal of remaining principal shores.
- D. Align joints and make watertight. Keep form joints to a minimum.
- E. Provide chamfer strips on external corners of formwork including retaining wall tops.
- F. Coordinate this section with other sections of work that require attachment of components to formwork.
- G. Joints and Stoppages:
 - 1. Construction Joints:
 - a. Install in accordance with provisions of ACI 318, Section 26.5.6.2, and as specified herein. Located where indicated or otherwise required and approved as to not impair strength of structure.
 - b. Provide nominal 3/4" x 2-1/2" key at construction joints, unless otherwise shown on drawings, or as directed by Structural Engineer.
 - c. Make joints perpendicular to principal reinforcement. Continue half reinforcement and mesh across joints except at isolation joints; provide longitudinal keys at least 1-1/2 inches deep at all joints in walls and between walls and slabs or footings.
 - d. Remove key-forming wood inserts and thoroughly clean surface of concrete at all joints, removing all laitance, before placing next lift.
 - e. Immediately prior to placing next lift and/or adjacent slab, dampen hardened concrete of joint surface and coat with neat cement mortar of similar proportions to mortar in concrete.
 - 2. Isolation/Expansion Joints For Slabs-On-Grade: Do not extend reinforcement through where bonded on both sides of joint; smooth dowels may extend through joint. Position accurately and support against displacement in locations listed hereinafter.
 - a. Interior Work:
 - 1) Install isolation/expansion joints between new interior ground-supported slabs and building foundation walls, and around isolated slabs at column structures; elsewhere where shown on Drawings.
 - 2) Install joints with top surface recessed below finish elevation 1/4 inch and fill with joint sealer as specified in Section 07 92 00, finished flush with slab surface.

**NISQUALLY STATE PARK
NEW FULL SERVICE PARK – PHASE 2**

b. Exterior Work:

- 1) Install as required in new walks and slabs in locations and/or spacings shown, elsewhere not more than 16 feet apart. Coordinate exact locations and alignment with Architect.
- 2) Install isolation/expansion joints between concrete walks/slabs and vertical building walls and retaining walls.
- 3) Install at all other locations indicated.
- 4) Install joints with top surface recessed below finish elevation 1/4 inch and fill with joint sealer as specified in Section 07 92 00, finished flush with slab surface.

3. Control Joints: As specified in Section 033000 Cast-in-Place Concrete and shown on the Drawings.

3.4 APPLICATION - FORM RELEASE AGENT

- A. Apply form release agent on formwork in accordance with manufacturer's recommendations.
- B. Apply prior to placement of reinforcing steel, anchoring devices, and embedded items.
- C. Do not apply form release agent where concrete surfaces will receive special finishes or applied coverings that are affected by agent. Soak inside surfaces of untreated forms with clean water. Keep surfaces coated prior to placement of concrete.

3.5 INSERTS, EMBEDDED PARTS, AND OPENINGS

- A. Provide formed openings where required for items to be embedded in passing through concrete work.
- B. Locate and set-in place items that will be cast directly into concrete.
- C. Coordinate with work of other sections in forming and placing openings, slots, recesses, sleeves, bolts, anchors, other inserts, and components of other work.
- D. Install accessories in accordance with manufacturer's instructions, so they are straight, level, and plumb. Ensure items are not disturbed during concrete placement.
- E. Prepare previously placed concrete by cleaning with steel brush and applying bonding agent in accordance with manufacturer's instructions.
- F. Install joint fillers, primer and sealant in accordance with manufacturer's instructions.
- G. Install joint covers in one piece longest practical length, when adjacent construction activity is complete.

3.6 FORM CLEANING

- A. All form cleaning will be accomplished within the Staging Area. No exceptions.

**NISQUALLY STATE PARK
NEW FULL SERVICE PARK – PHASE 2**

- B. Clean forms as erection proceeds, to remove foreign matter within forms.
- C. Clean formed cavities of debris prior to placing concrete.
- D. Flush with water or use compressed air to remove remaining foreign matter. Ensure that water and debris drain to exterior through clean-out ports.
- E. During cold weather, remove ice and snow from within forms. Do not use de-icing salts. Do not use water to clean out forms unless formwork and concrete construction proceed within heated enclosure. Use compressed air or other means to remove foreign matter.

3.7 FORMWORK TOLERANCES

- A. Construct formwork to maintain tolerances required by ACI 117, unless otherwise indicated.
- B. All curves shall have a consistent radii and vertical grade. Successive curves shall flow smoothly from one into another with no visible angle points. Straight tangents shall be unwavering in the horizontal and vertical alignment.

3.8 FIELD QUALITY CONTROL

- A. Quality Control: Field inspection and testing.
- B. Inspect erected formwork, shoring, and bracing to ensure that work is in accordance with formwork design, and to verify that supports, fastenings, wedges, ties, and items are secure. Do not reuse wood formwork more than 2 times. Do not patch formwork.

3.9 INSPECTION

- A. Notify Owner's Representative at commencement of formwork.
- B. Schedule an inspection of formwork with Owner's Representative 48 hours prior to expected time of completion of formwork. Obtain Owner's Representative's approval of formwork before placing concrete.

3.10 FORM REMOVAL

- A. Do not remove forms or bracing until concrete has gained sufficient strength to carry its own weight and imposed loads.
- B. Loosen forms carefully. Do not wedge pry bars, hammers, or tools against finish concrete surfaces scheduled for exposure to view.
- C. Store removed forms in manner that surfaces to be in contact with fresh concrete will not be damaged. Discard damaged forms.

END OF SECTION

**NISQUALLY STATE PARK
NEW FULL SERVICE PARK – PHASE 2**

SECTION 032000 – CONCRETE REINFORCING

PART 1 - GENERAL

1.1 SECTION INCLUDES

- A. Reinforcing steel for cast-in-place concrete.
- B. Welded wire fabric reinforcing for exterior concrete slabs on grade.
- C. Supports and accessories for steel reinforcement.

1.2 RELATED REQUIREMENTS

- A. Section 031000 - Concrete Forming and Accessories.
- B. Section 033000 - Cast-In-Place Concrete.

1.3 REFERENCE STANDARDS

- A. ACI 301 - Specifications for Structural Concrete “Latest Edition”.
- B. ACI 318 - Building Code Requirements for Structural Concrete and Commentary “Latest Addition”.
- C. ACI SP-66 - ACI Detailing Manual “Latest Addition”.
- D. ASTM A184/A184M - Standard Specification for Welded Deformed Steel Bar Mats for Concrete Reinforcement “Latest Addition”.
- E. ASTM A615/A615M - Standard Specification for Deformed and Plain Carbon-Steel Bars for Concrete Reinforcement “Latest Addition”.
- F. ASTM A706/A706M - Standard Specification for Deformed and Plain Low-Alloy Steel Bars for Concrete Reinforcement “Latest Addition”.
- G. ASTM A1064/A1064M - Standard Specification for Carbon-Steel Wire and Welded Wire Reinforcement, Plain and Deformed, for Concrete “Latest Addition”.
- H. CRSI (DA4) - Manual of Standard Practice “Latest Addition”.
- I. CRSI (P1) - Placing Reinforcing Bars “Latest Addition”.

**NISQUALLY STATE PARK
NEW FULL SERVICE PARK – PHASE 2**

1.4 SUBMITTALS

- A. Shop Drawings: Comply with requirements of ACI SP-66. Include bar schedules, shapes of bent bars, spacing of bars, and location of splices.
- B. Indicate bar sizes, spacings, locations, and quantities of reinforcing steel and wire fabric, bending and cutting schedules, and supporting and spacing devices.
- C. Prepare shop drawings under seal of a Professional Structural Engineer experienced in design of work of this type and licensed in Washington State.
- D. Manufacturer's Data: Submit manufacturer's product data and installation instructions for proprietary materials.
- E. Manufacturer's Certificate: Certify that reinforcing steel and accessories supplied for this project meet or exceed specified requirements.

1.5 QUALITY ASSURANCE

- A. Perform work of this section in accordance with ACI 301.
- B. Inspections: Covered hereinafter in this Section, and in Section 014300 Inspections and Tests. Should reinforcing placed under this Contract not meet specified requirements, remove and replace to assure compliance with Contract Documents.
- C. Welders' Certificates: Submit certifications for welders employed on the project, verifying AWS qualification within the previous 12 months and welders are WABO certified.

1.6 DELIVERY, STORAGE, AND PROTECTION

- A. Material and Equipment: Transport, handle, store, and protect products.
- B. All products to be stored in the Staging Area until day of use. All unused reinforcing steel and excess materials shall be immediately returned to the Staging Area after use.

PART 2 - PRODUCTS

2.1 REINFORCEMENT

- A. Reinforcing Steel:
 - 1. Unless otherwise noted in Structural Notes, furnish deformed bars meeting requirements set forth in ASTM Standard A615, Grade 60 ($F_y = 60,000$ psi). Bars shall be unpainted, uncoated, and free from rust, dirt and loose scale.
 - 2. Where reinforcing requires welded connections, furnish weldable reinforcing bars which meet the chemical requirements of ASTM A706 (Grade 60 ksi) with a minimum carbon equivalent of .55 percent.

**NISQUALLY STATE PARK
NEW FULL SERVICE PARK – PHASE 2**

- B. Welded Steel Wire Fabric: Furnish welded wire fabric meeting requirements set forth in ASTM A1064, $F_y=65$ ksi; 6"x6" - W 1.4/W 1.4 size, unless otherwise noted.
- C. Reinforcement Accessories:
 - 1. Tie Wire: 16 gauge or heavier, double annealed wire.
 - 2. Spacer Bars for Wall Reinforcing: 3-inch bars, "U" shaped. Stock items of equivalent function may be submitted for approval.
 - 3. Mortar Blocks:
 - a. Furnish as required for use as spacers in placing reinforcement; shall be two (2) inches square (maximum).
 - b. Mortar blocks shall be constructed of mortar mixed with the same proportions of sand and cement used in concrete and develop a minimum compressive strength of 4,000 psi at 28 days.
 - c. Mortar blocks shall have a tie wire embedded and the protruding ends to be tied to the reinforcing steel to hold the mortar blocks in place; mortar blocks with a grooved top may be used for supporting steel in slabs.
 - d. Metal Chair Supports: In lieu of mortar blocks, furnish approved heavy-duty plastic-type chair supports, sized to support all slab steel to proper height and with cushioned pads to prevent vapor retarder membrane penetration.
 - 4. Chairs, Bolsters, Bar Supports, and Spacers: Sized and shaped for strength and support of reinforcement during concrete placement conditions including load bearing pad on bottom to prevent vapor barrier puncture.
 - 5. Dowels shall comply with 9-07.5 Dowel Bars.

2.2 FABRICATION

- A. Fabricate concrete reinforcing in accordance with CRSI Manual of Practice.
- B. Locate reinforcing splices not indicated on drawings at point of minimum stress. Review locations of splices with Structural Engineer.
- C. Hooks & Bends
 - 1. Minimum Bend Diameter: The diameter of bend measured on the inside of the bar for standard hooks, other than stirrup and tie hooks, not less than:
 - 2. Bar sizes #3 through #8: 6 bar diameters.
 - a. Bar sizes #9 through #11: 8 bar diameters.
 - 3. Bending: Bend cold, unless otherwise permitted by Structural Engineer; do not field bend partially embedded bars except as permitted by Structural Engineer. Conform to ACI 318, Section 26.6.3.

**NISQUALLY STATE PARK
NEW FULL SERVICE PARK – PHASE 2**

PART 3 - EXECUTION

3.1 PLACEMENT

A. General:

1. Conform to ACI 318, Section 26.6.2 for placing, supports, tolerances, and draped fabric, unless noted otherwise on Drawings.
2. Place, support, and secure reinforcement against displacement. Do not deviate from required position.
3. Do not displace or damage vapor barrier.
4. Prevent water from softening soil under reinforcing during steel placing.
5. Accommodate placement of formed openings.

B. Maintain concrete cover around reinforcing as set forth on Drawings, but not less than 2 inches.

C. Cleaning Reinforcement: Clean reinforcement, at time concrete is placed, free of mud, oil, or other materials that will reduce the bond. Conform to ACI 318, Section 26.6.1.2.

D. Placement:

1. Reinforcing steel shall be accurately placed in accordance with related drawings, schedules, and detailed shop drawings and be securely tied and supported in its precise location at all points where the bars cross so as to preclude shifting during the placing of formwork, construction, or concrete placement operations.
2. Provide sufficient number of supports and of strength to carry the reinforcement. Do not place reinforcing bars more than 2 inches beyond last leg of any continuous bar support. Do not use supports as bases for runways for concrete conveying equipment and similar construction loads.
 - a. Bar reinforcing for concrete slabs on grade shall be securely supported in its proper position by means of mortar blocks or metal chairs as required; wood or foam supports are not acceptable.
 - 1) Use mortar blocks where placing reinforcing over vapor barrier or waterproof membranes at interior slabs on grade.
3. Metal chair supports may be used at exterior slabs.
 - a. Bar reinforcing shall be continuous insofar as practical and shall carry around corners and through intersections in footings and walls. Provide elbow bars of size to develop required laps.
 - b. Unless otherwise noted, reinforcing bar splices shall lap 40 bar diameters. Splices shall not be made at the points of maximum stress. Stagger all lap splices such that no more than 50% of horizontal or vertical bars shall splice at any location.
4. Fastening:
 - a. Securely tie bars and bar supports together with 16-gauge wire to hold reinforcement accurately in position during concrete placement.

**NISQUALLY STATE PARK
NEW FULL SERVICE PARK – PHASE 2**

- b. Set wire so that ends are directed into the concrete.
- c. Wire tie stirrups and ties to main reinforcement.

E. Placing Welded Wire Fabric:

- 1. Install in new exterior paving slabs. Provide of size specified herein or otherwise indicated, and with minimum coverages indicated for concrete protection.
- 2. Install welded wire fabric in as long lengths as practicable. The mesh fabric shall be rolled out, straightened, cut to the required size, and be laid reasonably flat in place.
- 3. Lap adjoining pieces at least 12 inches or one full mesh spacing plus 2 inches, whichever is greater, and lace splices with 16-gauge wire. Offset end laps in adjacent widths to prevent continuous laps in either direction.
- 4. Do not carry through isolation/expansion joints.
- 5. Prior to concrete placement, the mesh reinforcing shall be supported at frequent intervals as required to insure proper location in the concrete.
- 6. Lifting mesh reinforcing during concrete placement is not allowed, unless approved in writing by the Structural Engineer.

3.2 FIELD QUALITY CONTROL

- A. An independent testing agency will inspect installed reinforcement for conformance to Contract Documents before concrete placement.

END OF SECTION

**NISQUALLY STATE PARK
NEW FULL SERVICE PARK – PHASE 2**

SECTION 033000 – CAST-IN-PLACE CONCRETE

PART 1 - GENERAL

1.1 SUMMARY

A. Section Includes:

1. Form-facing material for cast-in-place concrete.
2. Form liners.
3. Shoring, bracing, and anchoring.
4. Steel reinforcement bars.
5. Welded-wire reinforcement.
6. Cast-in-place concrete.
7. Concrete materials.
8. Mixture design.
9. Placement procedures.
10. Finishes.

B. Related Requirements:

1. Section 033543 – Polished Concrete Finishing.
2. Section 055000 – Metal Fabrications, for abrasive nosings.

C. Products Installed But Not Furnished Under This Section:

1. Anchor bolts, steel pipe sleeves, slotted-channel inserts, and wedge-type inserts indicated to be cast into concrete.
2. Steel weld plates and angles for casting into concrete for applications where they are not specified in other Sections.

1.2 DEFINITIONS

- A. Cementitious Materials: Portland cement alone or in combination with one or more of the following: blended hydraulic cement, fly ash, slag cement, other pozzolans, and silica fume; materials subject to compliance with requirements.
- B. Self-Consolidating Concrete (SCC): Highly flowable, non-segregating concrete that can spread into place, fill formwork, and encapsulate reinforcement without any mechanical consolidation.
- C. Water/Cement Ratio (w/cm): Ratio by weight of water to cementitious materials.

1.3 ADMINISTRATIVE REQUIREMENTS

- A. Preinstallation Meeting: Conduct meeting at Project site.

**NISQUALLY STATE PARK
NEW FULL SERVICE PARK – PHASE 2**

1. Before submitting design mixtures, review concrete design mixture and examine procedures for ensuring quality of concrete materials. Require representatives of each entity directly concerned with cast-in-place concrete to attend, including the following:
 - a. Contractor.
 - b. Contractor's superintendent.
 - c. Owner.
 - d. Architect.
 - e. Structural engineer.
 - f. Installer.
 - g. Manufacturer representatives.
 - h. Independent testing agency responsible for concrete design mixtures.
 - i. Ready-mix concrete manufacturer.
 - j. Concrete Subcontractor.
 - k. Special concrete finish Subcontractor.

2. Review Project schedule, special inspection and testing and inspecting agency procedures for field quality control, concrete finishes and finishing, cold- and hot-weather concreting procedures, curing procedures, construction contraction and isolation joints, and joint-filler strips, semirigid joint fillers, forms and form removal limitations, shoring and reshoring procedures, vapor-retarder installation, anchor rod and anchorage device installation tolerances, steel reinforcement installation, methods for achieving specified floor and slab flatness and levelness floor and slab flatness and levelness measurement, concrete repair procedures, and concrete protection.

1.4 ACTION SUBMITTALS

A. Product Data: For each type of product.

1. Portland cement.
2. Fly ash.
3. Slag cement.
4. Blended hydraulic cement.
5. Silica fume.
6. Performance-based hydraulic cement.
7. Aggregates.
8. Admixtures:
 - a. Include limitations of use, including restrictions on cementitious materials, supplementary cementitious materials, air entrainment, aggregates, temperature at time of concrete placement, relative humidity at time of concrete placement, curing conditions, and use of other admixtures.
9. Fiber reinforcement.
10. Vapor retarders.
11. Liquid floor treatments.
12. Curing materials.
13. Joint fillers.
14. Repair materials.

**NISQUALLY STATE PARK
NEW FULL SERVICE PARK – PHASE 2**

B. Design Mixtures: For each concrete mixture, include the following:

1. Mixture identification.
2. Minimum 28 day compressive strength.
3. Durability exposure class.
4. Maximum w/c ratios.
5. Slump limit.
6. Air content.
7. Nominal maximum aggregate size.
8. Synthetic micro-fiber content.
9. Indicate amounts of mixing water to be withheld for later addition at Project site.
10. Alternate design mixtures when characteristics of materials, Project conditions, weather, test results, or other circumstances warrant adjustments.

C. Shop Drawings: Prepared by or under supervision of a qualified professional engineer.

1. Formwork: Detail fabrication, assembly, and support of formwork.
 - a. Shoring and Reshoring: Indicate proposed schedule and sequence of stripping formwork, shoring removal, and reshoring installation and removal.
2. Concrete Forming and Accessories:
 - a. For exposed vertical concrete walls, indicate dimensions and form tie locations.
 - b. Indicate dimension and locations of construction and movement joints required to construct structure in accordance with ACI 301.
 - 1) Location of construction joints is subject to approval of Architect.
 - c. Indicate location of waterstops.
 - d. Indicate form liner layout and form line termination details.
 - e. Indicate proposed schedule and sequence of stripping of forms, shoring removal, and reshoring installation and removal.
3. Concrete Reinforcing: Comply with ACI SP-066, and include the following:
 - a. Placing drawings that detail fabrication, bending, and placement.
 - b. Bar sizes, lengths, materials, grades, bar schedules, stirrup spacing, bent bar diagrams, bar arrangement, location of splices, lengths of lap splices, details of mechanical splice couplers, details of welding splices, tie spacing, hoop spacing, and supports for concrete reinforcement.
4. Cast-In-Place Concrete:
 - a. Construction Joint Layout: Indicate proposed construction joints required to construct structure.
 - 1) Location of construction joints is subject to approval of Architect.

**NISQUALLY STATE PARK
NEW FULL SERVICE PARK – PHASE 2**

5. Submit Shop Drawings that have been prepared, signed, and sealed by a qualified professional engineer licensed in Washington State.
- D. Samples:
1. Waterstops.
 2. Vapor retarder.
 3. Form Liners: 12 inch square Sample, indicating texture.
- E. Concrete Schedule: For each location of each Class of concrete indicated in "Concrete Mixtures" Article, including the following:
1. Concrete Class designation.
 2. Location within Project.
 3. Exposure Class designation.
 4. Formed Surface Finish designation and final finish.
 5. Final finish for floors.
 6. Curing process.
 7. Liquid floor treatment.
- 1.5 INFORMATIONAL SUBMITTALS
- A. Qualification Data: For Installer, manufacturer, and testing and inspection agency.
1. Installer: Include copies of applicable ACI certificates.
 2. Ready-mixed concrete manufacturer.
 3. For professional engineer indicating experience with providing delegated-design engineering services of the kind indicated.
 - a. Include documentation that engineer is licensed in Washington State.
- B. Material Certificates: For each of the following, signed by manufacturers:
1. Cementitious materials.
 2. Admixtures.
 3. Fiber reinforcement.
 4. Waterstops.
 5. Liquid floor treatments.
 6. Curing materials.
 7. Bonding agents.
 8. Adhesives.
 9. Vapor retarders.
 10. Semirigid joint filler.
 11. Joint-filler strips.
 12. Repair materials.
 13. Form materials and form-release agents.
 14. Steel reinforcement and accessories.
- C. Welding Certificates.

**NISQUALLY STATE PARK
NEW FULL SERVICE PARK – PHASE 2**

1. Reinforcement To Be Welded: Welding procedure specification in accordance with AWS D1.4.
- D. Material Test Reports: For the following, from a qualified testing agency:
1. Steel Reinforcement:
 - a. For reinforcement to be welded, mill test analysis for chemical composition and carbon equivalent of the steel in accordance with ASTM A706.
 2. Mechanical splice couplers.
 3. Portland cement.
 4. Fly ash.
 5. Slag cement.
 6. Blended hydraulic cement.
 7. Silica fume.
 8. Aggregates.
 9. Admixtures:
 - a. Permeability-Reducing Admixture: Include independent test reports, indicating compliance with specified requirements, including dosage rate used in test.
- E. Research Reports:
1. For concrete admixtures in accordance with ICC's Acceptance Criteria AC198.
 2. For sheet vapor retarder, showing compliance with ICC AC380.
- F. Preconstruction Test Reports: For each mix design.
- G. Floor surface flatness and levelness measurements indicating compliance with specified tolerances.
- H. Minutes of preinstallation meeting.
- 1.6 QUALITY ASSURANCE
- A. Installer Qualifications: A qualified installer with a minimum 3 years of experience who employs on Project personnel qualified as ACI-certified Flatwork Technician and Finisher and a supervisor who is an ACI-certified Concrete Flatwork Technician.
 - B. Delegated-Design Engineer Qualifications: Professional engineer experienced in providing delegated-design engineering services of the kind indicated and is legally qualified to practice in Washington State.
 - C. Ready-Mixed Concrete Manufacturer Qualifications: A firm with a minimum 10 years of experience in manufacturing ready-mixed concrete products and that complies with ASTM C94 requirements for production facilities and equipment.
 1. Manufacturer member of NRMCA and certified according to NRMCA's "Certification of Ready Mixed Concrete Production Facilities."

**NISQUALLY STATE PARK
NEW FULL SERVICE PARK – PHASE 2**

- D. Welding Qualifications: Qualify procedures and personnel according to the following:
 - 1. AWS D1.4.
 - 2. Use welders certified by AWS and State project is located for structural welding, and who have undergone recertification in the last 12 months.
- E. Field Samples: Comply with requirements in Section 014336 – Field Samples.
 - 1. Build field samples approximately 200 sq. ft. for slabs-on-ground and 100 sq. ft. for formed surfaces.
 - 2. Demonstrate typical joints, surface finish, texture, tolerances, and standard of workmanship.
 - a. Demonstrate repair of blemished or damaged portion of exposed-face surface in presence of Architect.

1.7 DELIVERY, STORAGE, AND HANDLING

- A. Comply with ASTM C94 and ACI 301.
- B. Form Liners: Store form liners under cover to protect from sunlight.
- C. Steel Reinforcement: Deliver, store, and handle steel reinforcement to prevent bending and damage, and to avoid damaging coatings on steel reinforcement.
- D. Waterstops: Store waterstops under cover to protect from moisture, sunlight, dirt, oil, and other contaminants.

1.8 FIELD CONDITIONS

- A. Cold-Weather Placement: Comply with ACI 306.1 and as follows:
 - 1. Protect concrete Work from physical damage or reduced strength that could be caused by frost, freezing actions, or low temperatures.
 - 2. When average high and low temperature is expected to fall below 40 deg F for 3 successive days, maintain delivered concrete mixture temperature within temperature range required by ACI 301.
 - 3. Do not use frozen materials or materials containing ice or snow.
 - 4. Do not place concrete on frozen subgrade or on subgrade containing frozen materials.
 - 5. Do not use calcium chloride, salt, or other materials containing antifreeze agents or chemical accelerators unless otherwise specified and approved in mixture designs.
- B. Hot-Weather Placement: Comply with ACI 301 and ACI 305.1 and as follows:
 - 1. Cool ingredients before mixing to maintain concrete temperature below 90 deg F at time of placement. Chilled mixing water or chopped ice may be used to control temperature, provided water equivalent of ice is calculated to total amount of mixing water.
 - a. Contractor's Option: Use of liquid nitrogen to cool concrete.

**NISQUALLY STATE PARK
NEW FULL SERVICE PARK – PHASE 2**

2. Fog-spray forms, steel reinforcement, and subgrade just before placing concrete. Keep subgrade uniformly moist without standing water, soft spots, or dry areas.

PART 2 - PRODUCTS

2.1 CONCRETE, GENERAL

- A. ACI Publications: Comply with the following unless modified by requirements in Contract Documents:
 1. ACI 301, Specification for Structural Concrete, Sections 1 through 5.
 2. ACI 117, "Specifications for Tolerances for Concrete Construction and Materials."

2.2 STEEL REINFORCEMENT

- A. Recycled Content of Steel Products: Postconsumer recycled content plus 1/2 of preconsumer recycled content not less than 75 percent.
- B. Reinforcing Bars: ASTM A615, Grade 60, except No. 3 may be Grade 40, deformed.
- C. Low-Alloy-Steel Reinforcing Bars: ASTM A706, Grade 60, deformed.
- D. Galvanized Reinforcing Bars:
 1. Steel Bars: ASTM A615, Grade 60, deformed.
 2. Zinc Coating: ASTM A767, Class I zinc coated after fabrication and bending.
- E. Deformed-Steel Wire: ASTM A1064, flat sheet.
- F. Steel Bar Mats: ASTM A184, fabricated from ASTM A615, Grade 60, deformed bars, assembled with clips.
- G. Welded-Wire Reinforcement:
 1. Plain Steel: ASTM A1064, plain, fabricated from as-drawn steel wire into flat sheets.
 - a. Do not provide rolls of wire where scheduled for slabs.
 2. Deformed-Steel: ASTM A1064, flat sheet.

2.3 REINFORCEMENT ACCESSORIES

- A. Joint Dowel Bars: ASTM A615, Grade 60, plain-steel bars, cut true to length with ends square and free of burrs.
- B. Bar Supports: Bolsters, chairs, spacers, and other devices for spacing, supporting, and fastening reinforcing bars, welded-wire reinforcement, and dowels in place.

**NISQUALLY STATE PARK
NEW FULL SERVICE PARK – PHASE 2**

1. Manufacture bar supports from steel wire, plastic, or precast concrete according to CRSI (DA4) of greater compressive strength than concrete and as follows:
 - a. For concrete surfaces exposed to view, where legs of wire bar supports contact forms, use all-plastic, CRSI Class 1 plastic-protected or hot-dip galvanized steel wire, or CRSI Class 2 stainless-steel bar supports.
 - b. Where reinforcing steel is supported on ground, provide precast concrete blocks not less than 4 sq. in. with compressive strength matching surrounding concrete.

- C. Galvanizing Repair Coating: Zinc-rich, cold galvanizing compound as specified in Section 055000 – Metal Fabrications.

2.4 CONCRETE MATERIALS

A. Source Limitations:

1. Obtain concrete mixtures from a single ready-mixed concrete manufacturer for entire Project.
2. Obtain each type or class of cementitious material of same brand from same manufacturer's plant.
3. Obtain aggregate from single source.
4. Obtain each type of admixture from single source from single manufacturer.

B. Cementitious Materials:

1. Portland Cement; ASTM C150; as follows:
 - a. Interior Locations: Type I and Type II. Do not use air entrained concrete at interior slabs.
 - b. Exterior Locations: Type I with specified air entrainment admixture, preferred to Type IA and Type IIA air-entrained concrete. Type IIIA acceptable for cold weather construction.
2. Fly Ash: ASTM C618, Class F or Class C pozzolan, loss on ignition not exceeding 1 percent. Account for lower calcium content of Class F where used.
3. Slag Cement: ASTM C989, Grade 120, ground, granulated blast-furnace slag.
4. Blended Hydraulic Cement: ASTM C595, Type II, portland-limestone cement.

C. Aggregates: ASTM C33, Class 3S coarse aggregate or better. Provide aggregates from a single source.

1. Maximum Coarse-Aggregate Size: As follows:
 - a. Slabs and Structural Concrete: Maximum 3/4 inch nominal.
 - b. Footings: Maximum 1 inch nominal.
2. Fine Aggregate: Free of materials with deleterious reactivity to alkali in cement.
3. Gradation: Uniformly graded.

**NISQUALLY STATE PARK
NEW FULL SERVICE PARK – PHASE 2**

- D. Self-Consolidating Concrete (SCC): Polycarboxylate based superplasticizers designed to consolidate concrete without need for vibrating.
1. Products: Subject to compliance with requirements, provide one of the following:
 - a. Euclid Chemical Co.: Plastol Series.
 - b. GCP Applied Technologies Inc.: ADVA Cast 530 or other ADVA Series product recommended by manufacturer.
 - c. Sika Corporation: Sika ViscoFlow-2020.
 - d. Approved substitution.
- E. Self-Consolidating Concrete (SCC): Polycarboxylate based superplasticizers designed to consolidate concrete without need for vibrating.
1. Products: Subject to compliance with requirements, provide one of the following:
 - a. Euclid Chemical Co.: Plastol Series.
 - b. GCP Applied Technologies Inc.: ADVA Cast 530 or other ADVA Series product recommended by manufacturer.
 - c. Sika Corporation: Sika ViscoFlow-2020.
 - d. Approved substitution.
- F. Water: ASTM C94; potable.

2.5 ADMIXTURES

- A. Chemical Admixtures: Certified by manufacturer to be compatible with other admixtures and that do not contribute water-soluble chloride ions exceeding those permitted in hardened concrete.
1. Do not use calcium chloride or admixtures containing calcium chloride.
- B. Air-Entraining Admixture: ASTM C260.
1. Products: Subject to compliance with requirements, provide one of the following:
 - a. Euclid Chemical Co.: Eucon Dura-Plus.
 - b. Master Builders Solutions: MasterAir Series.
 - c. Sika Corporation: Sika Air Series.
 2. Achieve 5 percent entrained air, plus or minus 1-1/2 percent to batch plant concrete mix, for exterior concrete exposed to earth, weather, or freezing temperatures after curing.
 3. Applications:
 - a. Exterior concrete unless indicated otherwise
 - b. Do not use on interior slabs unless approved in writing by Architect.
- C. Water-Reducing Admixture: ASTM C494, Type A: Low range and mid-range.

**NISQUALLY STATE PARK
NEW FULL SERVICE PARK – PHASE 2**

1. Products, Water Reducer: Subject to compliance with requirements, provide one of the following:
 - a. Euclid Chemical Co.: Eucon WR.
 - b. Master Builders Solutions: MasterPozzoloth Series.
 - c. Sika Corporation: Plastocrete 161.
 2. Products, Mid-Range: Subject to compliance with requirements, provide one of the following:
 - a. Euclid Chemical Co.: Eucon MR.
 - b. Master Builders Solutions: MasterPolyheed Series.
 - c. Sika Corporation: SikaPlaast-200.
 3. Applications: General use concrete unless another type is indicated.
- D. High-Range, Water-Reducing Admixture: ASTM C494, Type F: High range.
1. Products: Subject to compliance with requirements, provide one of the following:
 - a. Euclid Chemical Co.: Eucon 37.
 - b. Master Builders Solutions: MasterGlenium Series.
 - c. Sika Corporation: Sikament Series.
 2. Applications: Self-consolidating and pumped concrete.
- E. Permeability-Reducing Admixture: ASTM C494, Type S, hydrophilic, permeability-reducing crystalline admixture, capable of reducing water absorption of concrete exposed to hydrostatic pressure (PRAH).
1. Products: Subject to compliance with requirements, provide one of the following:
 - a. AQUAFIN, Inc.: AQUAFIN IC ADMIX- Powder.
 - b. Barrier One, Inc.: Barrier One WPX.
 - c. Euclid Chemical Co.: Vandex AM-10
 - d. ISE Logik Industries: CWPA 800.
 - e. Kryton International Inc.: Krystol Internal Membrane (KIM).
 - f. Master Builders Solutions: MasterLife 300 Series
 - g. Penetron International: Penetron Admix.
 - h. Sika Corporation: Sika WT-215 P or Sika WT-240 P.
 - i. Specialty Products Group: Vapor Lock 20/20
 - j. Xypex Chemical Corporation: Admix C-500/C-500 NF
 2. Performance Requirements:
 - a. Permeability: U.S. Army Corps of Engineers CRD C48; no leakage at hydraulic pressure of 200 psi for 14 days.
 - b. Complies with ACI 212.3R.
 - c. NSF/ANSI Standard 61 certified for use with potable water.
 - d. Compressive Strength: ASTM C39; increase 28 day strength by at least 8 percent when compared to untreated concrete

**NISQUALLY STATE PARK
NEW FULL SERVICE PARK – PHASE 2**

- e. Crack Sealing: Capable of self-sealing static cracks with widths up to 0.02 inch.
- 3. Applications: Concrete requiring integral waterproofing.
- F. Moisture Vapor Reduction Admixture (MVRA): Liquid, inorganic admixture free of volatile organic compounds (VOCs) and formulated to close capillary systems formed during curing to reduce moisture vapor emission and transmission, with no adverse effect on concrete properties.
 - 1. Products: Subject to compliance with requirements, provide one of the following:
 - a. Barrier One, Inc.: Barrier One MVRA-CPS.
 - b. Hycrete, Inc.: Hycrete W1000
 - c. ISE Logik Industries: MVRA 900.
 - d. Approved substitutions.
 - 2. Performance Requirements:
 - a. NSF/ANSI Standard 61 certified for use with potable water.
 - b. Certified by admixture manufacturer to not interfere with bonding of floor coverings.
 - 3. Applications: Interior slabs scheduled to receive adhesively applied flooring.

2.6 FIBER REINFORCEMENT

- A. Synthetic Monofilament Micro-Fiber: Monofilament polypropylene micro-fibers engineered and designed for use in concrete, complying with ASTM C1116, Type III.
 - 1. Products: Subject to compliance with requirements, provide one of the following:
 - a. Euclid Chemical Co.: PSI Fiberstrand 100 or PSI Fiberstrand 150.
 - b. Fibermesh; a Sika Brand: Fibermesh 150e3.
 - c. FORTA Corporation: FORTA Econo-Mono.
 - d. GCP Applied Technologies Inc.: Sinta M3019.
 - e. Master Builders Solutions: MasterFiber M35 or MasterFiber M70.
 - f. Nycon Corp.: ProCon-M.
 - g. Sika Corporation: SikaFiber HP.
 - h. Approved substitution.
 - 2. Length: Minimum 3/4 inch.
 - 3. Applications: Interior exposed slabs.
 - a. Not for use at composite slabs or as replacement for welded-wire fabric.
- B. Synthetic Fibrillated Micro-Fiber: Fibrillated polypropylene micro-fibers engineered and designed for use in concrete, complying with ASTM C1116, Type III.
 - 1. Products: Subject to compliance with requirements, provide one of the following:
 - a. Euclid Chemical Co.: PSI Fiberstrand F.

**NISQUALLY STATE PARK
NEW FULL SERVICE PARK – PHASE 2**

- b. Fibermesh; a Sika Brand: Fibermesh 300.
 - c. FORTA Corporation: FORTA Econo-Net.
 - d. GCP Applied Technologies Inc.: Sintar F19.
 - e. Master Builders Solutions: MasterFiber F100.
 - f. Nycon Corp.: ProCon-F.
 - g. Sika Corporation: SikaFiber PPF.
 - h. Approved substitution.
- 2. Length: Minimum 3/4 inch.
 - 3. Applications: Interior slabs schedules for floor coverings, exterior slabs.
 - a. Not for use at composite slabs or as replacement for welded-wire fabric.

2.7 WATERSTOPS

- A. Self-Expanding Butyl Strip Waterstops: Manufactured rectangular or trapezoidal strip, butyl rubber with sodium bentonite or other hydrophilic polymers, for adhesive bonding to concrete.
 - 1. Products: Subject to compliance with requirements, provide one of the following:
 - a. Carlisle Coatings & Waterproofing Inc.: MiraSTOP.
 - b. CETCO – Building Materials Group: Waterstop-RX-101.
 - c. Concrete Sealants Inc.: Con Seal CS-231.
 - d. GCP Applied Technologies Inc.: Adcor ES.
 - e. Henry Company: Hydro-Flex.
 - f. JP Specialties, Inc.: Earth Shield Type 20.
 - g. Sika Corporation: Swellstop.
 - h. Tremco Incorporated: Superstop.
 - i. W. R. Meadows, Inc.: Waterstop EC Plus.
 - 2. Size: 1 x 3/4 inches.
 - 3. Shape: Rectangular or trapezoidal.
 - 4. Physical Properties:
 - a. Hydrostatic-Head Resistance: 200 feet; ASTM D5385, modified.
 - 5. Configurations: As indicated on Drawings. Do not use for expansion joints.

2.8 VAPOR RETARDERS

- A. Sheet Vapor Retarder: ASTM E1745, Class A. Include manufacturer's recommended adhesive or pressure-sensitive tape.
 - 1. Products: Subject to compliance with requirements, provide one of the following:
 - a. Fortifiber Building Systems Group: Moistop Ultra 15.
 - b. GCP Applied Technologies Inc.: Florprufe 120.
 - c. Insulation Solutions, Inc.: Viper Vaporcheck II 15-mil.

**NISQUALLY STATE PARK
NEW FULL SERVICE PARK – PHASE 2**

- d. Raven Engineered Films.: VaporBlock 15.
- e. Reef Industries, Inc.: Griffolyn 15 mil Green. Stego Industries, LLC: Stego Wrap Vapor Barrier (15-Mil).
- g. W.R. Meadows, Inc.: Perminator 15 mil.
- h. Approved substitution.

2.9 LIQUID FLOOR TREATMENTS

A. Penetrating Liquid Floor Treatment (Type-1): Clear, chemically reactive, waterborne solution of inorganic silicate or silicate materials and proprietary components; odorless; that penetrates, hardens, seals, and densifies concrete surfaces.

1. Products: Subject to compliance with requirements, provide one of the following:

- a. Curecrete Distribution Inc.: Ashford Formula.
- b. Dayton Superior: Sure Hard Densifier J17.
- c. Nox-Crete Inc.: Duro-Nox.
- d. Laticrete International, Inc.: Seal Hard.
- e. Master Builders Solutions: MasterKure HD 200WB.
- f. SpecChem, LLC: SpecHard.
- g. W.R. Meadows, Inc.: LIQUI-HARD.

B. Penetrating Liquid Floor Treatment (Type-2): Spray-applied, clear, odorless, non-toxic, non-flammable, penetrating colloidal silica concrete treatment designed to harden, densify, and seal concrete surfaces.

1. Products: Subject to compliance with requirements, provide one of the following:

- a. AQURON Corporation International: Aquron 2000 Cure & Sea.
- b. Solomon Colors, Inc.: Lythic Densifier.
- c. Spray-Lock Concrete Protection, LLC: SCP 327 – Time of Placement SCP 327.
- d. Approved substitution.

2.10 CURING MATERIALS

A. Curing Materials, General:

1. Verify products comply with requirements of California Department of Public Health's "Standard Method for the Testing and Evaluation of Volatile Organic Chemical Emissions from Indoor Sources Using Environmental Chambers."

B. Evaporation Retarder: Waterborne, monomolecular film forming, manufactured for application to fresh concrete to reduce rapid surface moisture evaporation.

1. Products: Subject to compliance with requirements, provide one of the following:

- a. Dayton Superior: AquaFilm J74RTU or AquaFilm Concentrate J74.
- b. Euclid Chemical Co.: Eucobar.

**NISQUALLY STATE PARK
NEW FULL SERVICE PARK – PHASE 2**

- c. Kaufman Products, Inc.: VaporAid.
 - d. Lambert Corporation: LAMBCO Skin.
 - e. Laticrete International, Inc.: E-CON.
 - f. Master Builders Solutions: MasterKure ER 50.
 - g. Nox-Crete Inc.: Monofilm.
 - h. Vexcon Chemicals, Inc.: Starseal Assist.
 - i. W.R. Meadows, Inc.: Evapre or Evapre-RTU.
2. Concentrated versions of specified products are acceptable subject to concentrates being used according to manufacturers' written instructions.
3. Applications: Apply to exterior concrete surfaces immediately after concrete placement and awaiting finishing in hot, dry, and windy conditions.
- C. Absorptive Cover: AASHTO M 182, Class 2, burlap cloth made from jute or kenaf, weighing approximately 9 oz./sq. yd. when dry.
- D. Moisture-Retaining Cover: Provide one of the following that complies with ASTM C171:
- 1. Impervious paper consisting of 2 sheets of kraft paper cemented together by a bituminous adhesive with fiber reinforcement.
 - 2. Polyethylene film, clear or white, minimum nominal thickness of 0.0040 inch.
 - 3. White-burlap-polyethylene sheet, 40 inches wide, weighing not less than 10 oz./lin. yd.
 - 4. Color: Comply with the following color restrictions for ambient temperatures:
 - a. Ambient Temperature Below 50 deg F: Black.
 - b. Ambient Temperature between 50 deg F and 85 deg F: Any color.
 - c. Ambient Temperature Above 85 deg F: White.
- E. Curing Paper: Nonstaining, waterproof, 8 foot wide paper, consisting of 2 layers of kraft paper cemented together and reinforced with fiber, and complying with ASTM C171.
- 1. Products: Subject to compliance with requirements, provide one of the following:
 - a. Fortifiber Building Systems Group: Sisalkraft SK-10.
 - b. Approved substitution.
- F. Curing Compound: ASTM C309, clear, waterborne, membrane-forming, dissipating, Type 1, Class A and B.
- 1. Products: Subject to compliance with requirements, provide one of the following:
 - a. Dayton Superior: Clear Resin Cure J11W.
 - b. Euclid Chemical Co.: Kurez DR-100.
 - c. Kaufman Products, Inc.: Thinfilm 420.
 - d. Nox-Crete Inc.: Clear Cure DH 100.
 - e. Laticrete International, Inc.: L&M Cure.
 - f. W.R. Meadows, Inc.: 1100.
 - g. Approved substitution.
 - 2. Certified by curing compound manufacturer to not interfere with bonding of floor coverings.

**NISQUALLY STATE PARK
NEW FULL SERVICE PARK – PHASE 2**

G. Curing and Sealing Compound: ASTM C1315, clear, waterborne, membrane-forming, Type 1, Class A. Product contains acrylic copolymers.

1. Products: Subject to compliance with requirements, provide one of the following:

- a. Dayton Superior: Cure & Seal 1315 J22WB.
- b. Euclid Chemical Co.: Super Diamond Clear VOX.
- c. Kaufman Products, Inc.: Krystal 25 Emulsion.
- d. Laticrete International, Inc.: L&M Dress & Seal WB 25.
- e. Master Builders Solutions: MasterKure CC 1315WB.
- f. Nox-Crete Inc.: Cure & Seal 250 E.
- g. W.R. Meadows, Inc.: Vocomp-25.
- h. Approved substitution.

H. Water: Potable or complying with ASTM C1602.

2.11 RELATED MATERIALS

A. Reglets: Fabricate reglets of not less than 0.022 inch thick, galvanized-steel sheet. Temporarily fill or cover face opening of reglet to prevent intrusion of concrete or debris.

1. Sizes: As indicated on Drawings.

B. Dovetail Anchor Slots: Hot-dip galvanized-steel sheet, not less than 0.034 inch thick, with bent tab anchors. Temporarily fill or cover face opening of slots to prevent intrusion of concrete or debris.

C. Expansion- and Isolation-Joint-Filler Strips: ASTM D1751, asphalt-saturated cellulosic fiber.

1. Products: Subject to compliance with requirements, provide one of the following:

- a. Masco Masons Supply Company: Reflex Rubber Joint.
- b. Right Pointe Company: Right-Joint Fibre Expansion Joint.
- c. SpecChem: SpecFlex Fiber Expansion Joint.
- d. W. R. Meadows: FIBRE Expansion Joint.
- e. Western Louisville Fiberboard: WLF Expansion Joint.
- f. Approved substitution.

2. Thickness: 3/4 inch unless indicated otherwise.

D. Removable, Plastic, Expansion-Joint Cap: Rigid, recycled PVC joint cap with removable top strip.

1. Products: Subject to compliance with requirements, provide one of the following:

- a. BoMetals, inc.: Expansion Board Cap.
- b. Superior Profiles: VoidCap.
- c. W. R. Meadows: SNAP-CAP Expansion Joint Cap.
- d. Approved substitution.

2. Size: 1/2 inch wide by 1/2 inch deep.

**NISQUALLY STATE PARK
NEW FULL SERVICE PARK – PHASE 2**

- E. Semi-Rigid Joint Filler (SR.JNT-1): 2-component, semi rigid, 100 percent solids, aromatic polyurea.
1. Polyurea Products: Subject to compliance with requirements, provide one of the following:
 - a. Adhesives Technology Corp.: Crackbond JF-82 Fast.
 - b. ARDEX Americas: Ardiseal Rapid Plus.
 - c. Curecrete Distribution Inc.: CreteFill Pro 85.
 - d. Euclid Chemical Company (The): Euco Qwikjoint UVR.
 - e. Laticrete International, Inc.: L&M Joint Tite 750.
 - f. MAPEI Corporation: Planiseal RapidJoint 15.
 - a. Master Builders Solutions: MasterSeal CR 100.
 - b. Sika Corporation: Sika Loadflex-524 EZ.
 - c. Approved substitution.
 2. Colors: Standard gray unless selected otherwise by Architect from manufacturer's full color range.
 3. Shore A Durometer Hardness: ASTM D2240; 85 to 95 minimum.
 4. Tensile Strength: When tested according to:
 - a. ASTM D412; minimum 600 psi.
 - b. ASTM D638; minimum 920 percent.
 5. Elongation: When tested according to:
 - a. ASTM D412; minimum 200 percent.
 - b. ASTM D638; minimum 180 percent.
 - c. ASTM C321, minimum 250 percent
 6. Locations:
 - a. Joints in interior concrete slabs scheduled to receive concrete polishing systems.
 - b. Where indicated.
- F. Keyed Control Joint Devices: Keyed control joint system with tongue and groove profile, removable top plastic cap sealant trough, knockout holes on 6 inch centers for dowels, and ribbed steel spikes with tongue to fit top screed edge.
1. Products: Subject to compliance with requirements, provide one of the following:
 - a. BoMetals, inc.: Pro-Key.
 - b. Form-A-Key Products a div. of Cardinal Manufacturing Co.: Key-Loc Joint System.
 - c. Approved substitution.
 2. Materials:
 - a. Keyed Joint Form: ASTM A653, nominal 0.028 inch thick galvanized steel with G90 or thicker coating.
 - b. Stakes: ASTM A1011, minimum 0.064 inch nominal thickness, ribbed.
 - c. Removable Cap: Joint device manufacturer's standard 3/8 x 3/8 inch PVC cap.

**NISQUALLY STATE PARK
NEW FULL SERVICE PARK – PHASE 2**

- G. Bonding Agent: ASTM C1059, Type II, nonredispersible, acrylic emulsion or styrene butadiene.
- H. Floor Slab Protective Covering: 8 foot wide cellulose fabric.
 - 1. Application: Used to protect concrete floors schedule for polished concrete finishing.
 - 2. Manufacturers: Subject to compliance with requirements, provide products by the following:
 - a. McTech Group, Inc.: EZ Cover.
 - b. Approved substitution.

2.12 REPAIR MATERIALS

- A. Repair Underlayment: Cement-based, polymer-modified, self-leveling product that can be applied in thicknesses from 1/8 inch and that can be feathered at edges to match adjacent floor elevations.
 - 1. Cement Binder: ASTM C150 portland cement or hydraulic or blended hydraulic cement, as defined in ASTM C219.
 - 2. Primer: Product of underlayment manufacturer recommended for substrate, conditions, and application.
 - 3. Aggregate: Well-graded, washed gravel, 1/8 to 1/4 inch or coarse sand, as recommended by underlayment manufacturer.
 - 4. Compressive Strength: Not less than 4,100 psi at 28 days when tested in accordance with ASTM C109.
 - 5. Applications: At floor slab areas scheduled to receive floor coverings.
- B. Repair Overlayment: Cement-based, polymer-modified, self-leveling product that can be applied in thicknesses from 1/4 inch and that can be filled in over a scarified surface to match adjacent floor elevations.
 - 1. Cement Binder: ASTM C150, portland cement as defined in ASTM C219.
 - 2. Primer: Product of topping manufacturer recommended for substrate, conditions, and application.
 - 3. Aggregate: Well-graded, washed gravel, 1/8 to 1/4 inch or coarse sand as recommended by topping manufacturer.
 - 4. Compressive Strength: Not less than 5,000 psi at 28 day strength of concrete being repaired when tested according to ASTM C109.
 - 5. Applications: At floor slab areas scheduled to remain exposed coverings.

2.13 CONCRETE MIXTURES, GENERAL

- A. Prepare design mixtures for each type and strength of concrete, proportioned on basis of laboratory trial mixture or field test data, or both, according to ACI 301.
 - 1. Use a qualified independent testing agency for preparing and reporting proposed mixture designs based on laboratory trial mixtures.
- B. Cementitious Materials: Limit percentage, by weight, of cementitious materials other than portland cement in concrete as follows unless indicated otherwise on structural Drawings:

**NISQUALLY STATE PARK
NEW FULL SERVICE PARK – PHASE 2**

1. Fly Ash or Other Pozzolans: 35 percent maximum by mass.
 2. Slag Cement: 50 percent maximum by mass.
 3. Silica Fume: 5 percent maximum by mass.
 4. Combined Fly Ash or Other Pozzolans, Slag Cement, and Silica Fume: 50 percent by mass.
- C. Admixtures: Use admixtures according to manufacturer's written instructions.
1. Use water-reducing, high-range water-reducing, and plasticizing admixture in concrete, as required, for placement and workability.
 2. Use water-reducing and -retarding admixture when required by high temperatures, low humidity, or other adverse placement conditions.
- 2.14 CONCRETE MIXTURES FOR BUILDING ELEMENTS
- A. Proportion concrete mixes in accordance with requirements indicated in structural Drawing. The following requirements are a minimum standard.
- B. Class A: Normal-weight concrete.
1. Minimum Compressive Strength: As indicated on structural Drawings.
 2. Maximum w/c Ratio: As indicated in structural Drawings.
 3. Slump Limit: As indicated on structural Drawings.
 4. Air Content: At point of delivery for concrete containing: Not required for interior slabs on ground.
 - a. 5 percent, plus or minus 1.5 percent for 3/4 inch nominal maximum aggregate size.
 - b. 4.5 percent, plus or minus 1.5 percent for 1 inch nominal maximum aggregate size.
 5. Limit water-soluble, chloride-ion content in hardened concrete to 0.10 percent by weight of cement.
 6. Applications:
 - a. Footings, stem walls, grade beams, tie beams, and interior slabs on ground.
- C. Exterior Concrete: Normal-weight concrete.
1. Minimum Compressive Strength: 4,000 psi at 28 days.
 2. Maximum w/c Ratio: 0.42 to 0.5 unless indicated otherwise in civil Drawings.
 3. Minimum Cementitious Materials Content: 520 lb/cu. yd.
 4. Slump Limit: 3 inches, plus or minus 1 inch.
 5. Air Content: 4-1/2 to 7-1/2 percent, according to ASTM C231.
 6. Synthetic Micro-Fiber: Uniformly disperse in concrete mixture at manufacturer's recommended rate, but not less than a rate of 1.5 lb/cu. yd.
 7. Applications:
 - a. Exterior stoop slabs, exterior sidewalks, mechanical equipment pads, and other similar conditions.
- D. Class J: Normal-weight concrete used for exterior retaining walls.

**NISQUALLY STATE PARK
NEW FULL SERVICE PARK – PHASE 2**

1. Minimum Compressive Strength: 4,000 psi at 28 days.
- E. Self-Consolidating Concrete (SCC) Range of Slump Flow Values: Concrete free of rock pockets and honeycombs.
1. Slabs: 18 to 28 inch.
 2. Architectural Members: 24 to 30 inch.
 3. Walls, Normal Reinforcement: 18 to 28 inch.
 4. Walls and Columns, Heavy Reinforcement: 24 to 28 inch.
 5. Others: As indicated in structural Documents.
- 2.15 FABRICATING REINFORCEMENT
- A. Fabricate steel reinforcement according to CRSI (DA4).
- 2.16 CONCRETE MIXING
- A. Ready-Mixed Concrete: Measure, batch, mix, and deliver concrete according to ASTM C94 and ASTM C1116. Furnish batch certificates for each batch discharged and used in Work.
1. When air temperature is between 85 and 90 deg F, reduce mixing and delivery time from 1-1/2 hours to 75 minutes.
 2. When air temperature is above 90 deg F, reduce mixing and delivery time to 60 minutes.
 3. Monitor concrete in truck and reject if temperature rises to 89 deg F or 5 deg F in 10 minutes, indicating that concrete is setting up prior to discharge.
- B. Project-Site Mixing: Not permitted without Architect's written approval. If approved by Architect, measure, batch, and mix concrete materials and concrete according to ASTM C94. Mix concrete materials in appropriate drum-type batch machine mixer.
1. For concrete batches of 1 cu. yd. or smaller, continue mixing at least 1-1/2 minutes, but not more than 5 minutes, after ingredients are in mixer, before any part of batch is released.
 2. For concrete batches larger than 1 cu. yd., increase mixing time by 15 seconds for each additional 1 cu. yd.
 3. Provide batch ticket for each batch discharged and used in Work, indicating Project identification name and number, date, mixture type, mixture time, quantity, and amount of water added.
 4. Record approximate location of final deposit in structure.

PART 3 - EXECUTION

- 3.1 INSTALLATION OF FORMWORK
- A. Comply with ACI 301.

**NISQUALLY STATE PARK
NEW FULL SERVICE PARK – PHASE 2**

- B. Construct formwork so concrete members and structures are of size, shape, alignment, elevation, and position indicated, within tolerance limits of ACI 117 and to comply with Surface Finish designations specified in this Section for as-cast finishes.
- C. Limit concrete surface irregularities as follows:
 - 1. Surface Finish-1.0: ACI 117 Class D, 1 inch.
 - 2. Surface Finish-2.0: ACI 117 Class B, 1/4 inch.
 - 3. Surface Finish-3.0: ACI 117 Class A, 1/8 inch.
- D. Construct forms tight enough to prevent loss of concrete mortar and to minimize joints.
- E. Construct removable forms for easy removal without hammering or prying against concrete surfaces.
 - 1. Provide crush or wrecking plates where stripping may damage cast-concrete surfaces.
 - 2. Provide top forms for inclined surfaces steeper than 1.5 horizontal to 1 vertical.
 - 3. Install keyways, reglets, recesses, and other accessories, for easy removal.
- F. Do not use rust-stained, steel, form-facing material.
- G. Set edge forms, bulkheads, and intermediate screed strips for slabs to achieve required elevations and slopes in finished concrete surfaces.
 - 1. Provide and secure units to support screed strips
 - 2. Use strike-off templates or compacting-type screeds.
- H. At construction joints, overlap forms onto previously placed concrete not less than 12 inches.
- I. Construction and Movement Joints:
 - 1. Construct joints true to line with faces perpendicular to surface plane of concrete.
 - 2. Install so strength and appearance of concrete are not impaired, at locations indicated or as approved by Architect.
 - 3. Place joints perpendicular to main reinforcement.
 - 4. Locate joints for beams, slabs, joists, and girders in middle third of spans.
 - a. Offset joints in girders a minimum distance of twice beam width from a beam-girder intersection.
 - 5. Locate horizontal joints in walls and columns at underside of floors, slabs, beams, and girders and at top of footings or floor slabs.
 - 6. Space vertical joints in walls as indicated on Drawings.
 - a. Locate joints beside piers integral with walls, near corners, and in concealed locations where possible.
- J. Clean forms and adjacent surfaces to receive concrete. Remove chips, wood, sawdust, dirt, and other debris just before placing concrete.

**NISQUALLY STATE PARK
NEW FULL SERVICE PARK – PHASE 2**

- K. Retighten forms and bracing before placing concrete, as required, to prevent mortar leaks and maintain proper alignment.
- L. Coat contact surfaces of forms with form-release agent, according to manufacturer's written instructions, before placing reinforcement.

3.2 INSTALLATION OF EMBEDDED ITEMS

- A. Place and secure anchorage devices and other embedded items required for adjoining Work that is attached to or supported by cast-in-place concrete.
 - 1. Use setting drawings, templates, diagrams, instructions, and directions furnished with items to be embedded.
 - 2. Install anchor rods, accurately located, to elevations required and complying with tolerances in Section 7.5 of AISC 303.
 - 3. Install reglets to receive waterproofing and to receive through-wall flashings in outer face of concrete frame at exterior walls, where flashing is shown at lintels, shelf angles, and other conditions.
 - 4. Install dovetail anchor slots in concrete structures, as indicated on Drawings.
 - 5. Clean embedded items immediately prior to concrete placement.

3.3 INSTALLATION OF STEEL REINFORCEMENT

- A. Comply with CRSI (DA4) for fabricating, placing, and supporting reinforcement.
 - 1. Do not cut or puncture vapor retarder. Repair damage and reseal vapor retarder before placing concrete.
- B. Accurately position, support, and secure reinforcement against displacement.
 - 1. Maintain minimum concrete cover.
 - 2. Do not tack weld crossing reinforcing bars.
- C. Preserve clearance between bars of not less than 1 inch, not less than 1 bar diameter, or not less than 1-1/3 times size of large aggregate, whichever is greater.
- D. Provide concrete coverage in accordance with ACI 318.
- E. Set wire ties with ends directed into concrete, not toward exposed concrete surfaces.
- F. Splices: Lap splices as indicated on structural Drawings.
 - 1. Lap bars indicated to be continuous and vertical bars not less than 48 bar diameters at splices, or 24 inches, whichever is greater.
 - 2. Stagger splices in accordance with ACI 318.
 - 3. Mechanical Splice Couplers: Install in accordance with manufacturer's instructions.
 - 4. Weld reinforcing bars in accordance with AWS D1.4, where indicated on Drawings.

**NISQUALLY STATE PARK
NEW FULL SERVICE PARK – PHASE 2**

- G. Install welded-wire reinforcement in longest practicable lengths.
 - 1. Support welded-wire reinforcement in accordance with CRSI (DA4).
 - a. For reinforcement less than W4.0 or D4.0, continuous support spacing shall not exceed 12 inches.
 - 2. Lap edges and ends of adjoining sheets at least 1 wire spacing plus 2 inches, or 12 inches, whichever is greater, for plain wire and 8 inches for deformed wire.
 - 3. Offset laps of adjoining sheet widths to prevent continuous laps in either direction.
 - 4. Lace overlaps with wire.
- H. Zinc-Coated Reinforcement:
 - 1. Repair cut and damaged zinc coatings with galvanizing repair coating.
- I. Clean reinforcement of loose rust and mill scale, earth, ice, and other foreign materials that reduce bond to concrete, prior to placing concrete.

3.4 REMOVING AND REUSING FORMS

- A. Clean and repair surfaces of forms to be reused in Work.
 - 1. Split, frayed, delaminated, or otherwise damaged form-facing material are unacceptable for exposed surfaces.
 - 2. Apply new form-release agent.
- B. When forms are reused, clean surfaces, remove fins and laitance, and tighten to close joints.
 - 1. Align and secure joints to avoid offsets.
 - 2. Do not use patched forms for exposed concrete surfaces unless approved by Architect.

3.5 SHORING AND RESHORING

- A. Comply with ACI 301 and ACI 318 for design, installation, and removal of shoring and reshoring.
 - 1. Do not remove shoring or reshoring until measurement of slab tolerances is complete.
- B. Plan sequence of removal of shores and reshore to avoid damage to concrete. Locate and provide adequate reshoring to support construction without excessive stress or deflection.

3.6 INSTALLATION OF VAPOR-RETARDER

- A. Sheet Vapor Retarders: Place, protect, and repair sheet vapor retarder according to ASTM E1643 and manufacturer's written instructions.
 - 1. Lap joints 6 inches and seal with manufacturer's recommended tape.

**NISQUALLY STATE PARK
NEW FULL SERVICE PARK – PHASE 2**

3.7 JOINTS

- A. Form construction, isolation, and contraction joints and tool edges true to line, with faces perpendicular to surface plane of concrete. Construct transverse joints at right angles to centerline unless otherwise indicated.
- B. Construction Joints: Coordinate with floor slab pattern and concrete placement sequence.
 - 1. Install so strength and appearance of concrete are not impaired, at locations indicated or as approved by Architect.
 - 2. Place joints perpendicular to main reinforcement.
 - a. Terminate reinforcement at construction joints and provide smooth dowel across joint as indicated in structural Drawings.
 - b. Do not continue reinforcement through sides of strip placements of floors and slabs.
 - 3. Form keyed joints as indicated. Embed keys at least 1-1/2 inches into concrete.
 - 4. Locate joints for beams, slabs, joists, and girders in middle third of spans. Offset joints in girders a minimum distance of twice beam width from a beam-girder intersection.
 - 5. Locate horizontal joints in walls and columns at underside of floors, slabs, beams, and girders and at top of footings or floor slabs.
 - 6. Space vertical joints in walls as indicated on Drawings. Locate vertical joints beside piers integral with walls, near corners, and in concealed locations where possible.
 - 7. Use a bonding agent at locations where fresh concrete is placed against non-structural hardened or partially hardened concrete surfaces.
- C. Control Joints in Slabs-on-Ground: Form weakened-plane control joints, sectioning concrete into areas as indicated on Drawings and approved Shop Drawings. Construct control joints for a depth equal to at least 1/4 of concrete thickness, but not less than 1-1/4 inch, as follows:
 - 1. Early-Entry Sawed Joints: Form control joints on both interior and exterior slabs using early-entry dry-cut saws and methods in accordance with ACI 302.1R, Chapter 8. Acceptable alternatives include the following:
 - a. Sawed Joints: Form control joints with power saws equipped with shatterproof abrasive or diamond-rimmed blades. Cut 1/8 inch wide joints into concrete when cutting action does not tear, abrade, or otherwise damage surface and before concrete develops random cracks.
 - b. Grooved Joints: Form control joints after initial floating by grooving and finishing each edge of joint to a radius of 1/8 inch. Repeat grooving of control joints after applying surface finishes. Eliminate groover tool marks on concrete surfaces.
 - 2. Verify control joint forming methods and locations with Architect before proceeding.
- D. Expansion and Isolation Joints in Slabs-on-Ground: After removing formwork, install expansion- and isolation-joint-filler strips at slab junctions with vertical surfaces, such as foundation walls and other locations, as indicated.
 - 1. Extend joint-filler strips full width and depth of joint, terminating flush with finished concrete surface unless otherwise indicated.

**NISQUALLY STATE PARK
NEW FULL SERVICE PARK – PHASE 2**

2. Install joint-filler strips in lengths as long as practicable. Where more than 1 length is required, lace or clip sections together.
3. Where joint sealants, specified in Section 079200 – Joint Sealants, are indicated, place removable, plastic, expansion-joint cap over top of expansion- and isolation-joint material prior to placing of concrete to form a level, clean void for self-leveling joint sealant once concrete hardens.
 - a. Joint Sealant Depth: Not less than 1/2 inch or more than 1 inch below finished concrete surface

E. Doweled Joints:

1. Install dowel bars and support assemblies at joints where indicated.
2. Lubricate or asphalt coat 1/2 of dowel length to prevent concrete bonding to 1 side of joint.

3.8 INSTALLATION OF WATERSTOPS

- A. Self-Expanding Strip Waterstops: Install in construction joints and at other locations indicated, according to manufacturer's written instructions, adhesive bonding, mechanically fastening, and firmly pressing into place. Install in longest lengths practicable.
1. Install in longest lengths practicable.
 2. Locate waterstops in center of joint unless otherwise indicated on Drawings.
 3. Protect exposed waterstops during progress of Work.

3.9 CONCRETE PLACEMENT

- A. Notify Architect and testing and inspection agencies 24 hours prior to commencement of concrete placement.
- B. Before placing concrete, verify that installation of formwork, reinforcement, and embedded items is complete and that required inspections are completed.
1. Immediately prior to concrete placement, inspect vapor retarder for damage and deficient installation, and repair defective areas.
 2. Provide continuous inspection of vapor retarder during concrete placement and make necessary repairs to damaged areas as Work progresses.
- C. Do not add water to concrete during delivery, at Project site, or during placement unless approved by Architect in writing, but not to exceed the amount indicated on the concrete delivery ticket.
1. Do not add water to concrete after adding high-range water-reducing admixtures to mixture.
- D. Before test sampling and placing concrete, water may be added at Project site, subject to limitations of ACI 301, but not to exceed the amount indicated on the concrete delivery ticket.
1. Do not add water to concrete after adding high-range water-reducing admixtures to mixture.

**NISQUALLY STATE PARK
NEW FULL SERVICE PARK – PHASE 2**

- E. Deposit concrete continuously in 1 layer or in horizontal layers of such thickness that no new concrete is placed on concrete that has hardened enough to cause seams or planes of weakness.
1. If a section cannot be placed continuously, provide construction joints as indicated.
 2. Deposit concrete to avoid segregation.
 3. Deposit concrete in horizontal layers of depth not to exceed formwork design pressures and in a manner to avoid inclined construction joints.
 4. Consolidate placed concrete with mechanical vibrating equipment according to ACI 301.
 - a. Do not use vibrators to transport concrete inside forms.
 - b. Insert and withdraw vibrators vertically at uniformly spaced locations to rapidly penetrate placed layer and at least 6 inches into preceding layer.
 - c. Do not insert vibrators into lower layers of concrete that have begun to lose plasticity.
 - d. At each insertion, limit duration of vibration to time necessary to consolidate concrete, and complete embedment of reinforcement and other embedded items without causing mixture constituents to segregate.
- F. Deposit and consolidate concrete for floors and slabs in a continuous operation, within limits of construction joints, until placement of a panel or section is complete.
1. Do not place concrete floors and slabs in a checkerboard sequence.
 2. Consolidate concrete during placement operations, so concrete is thoroughly worked around reinforcement and other embedded items and into corners.
 3. Maintain reinforcement in position on chairs during concrete placement.
 4. Screed slab surfaces with a straightedge and strike off to correct elevations.
 5. Level concrete, cut high areas, and fill low areas.
 6. Slope surfaces uniformly to drains where required.
 7. Begin initial floating using bull floats or darbies to form a uniform and open-textured surface plane, before excess bleedwater appears on the surface.
 8. Do not further disturb slab surfaces before starting finishing operations.

3.10 FINISHING FORMED SURFACES

A. Related Unformed Surfaces:

1. At tops of walls, horizontal offsets, and similar unformed surfaces adjacent to formed surfaces, strike off smooth and finish with a texture matching adjacent formed surfaces.
2. Continue final surface treatment of formed surfaces uniformly across adjacent unformed surfaces unless otherwise indicated.

3.11 FINISHING FLOORS AND SLABS

A. Comply with ACI 302.1R recommendations for screeding, restraightening, and finishing operations for concrete surfaces. Do not wet concrete surfaces.

B. Scratch Finish:

1. While still plastic, texture concrete surface that has been screeded and bull-floated or darbied.

**NISQUALLY STATE PARK
NEW FULL SERVICE PARK – PHASE 2**

2. Use stiff brushes, brooms, or rakes to produce a profile amplitude of 1/4 inch in one direction.
- C. Float Finish:
1. When bleedwater sheen has disappeared and concrete surface has stiffened sufficiently to permit operation of specific float apparatus, consolidate concrete surface with power-driven floats or by hand floating if area is small or inaccessible to power-driven floats.
 2. Repeat float passes and restraightening until surface is left with a uniform, smooth, granular texture and complies with ACI 117 tolerances for conventional concrete.
 3. Locations:
 - a. Surfaces to receive trowel finish.
- D. Trowel Finish:
1. After applying float finish, apply first troweling and consolidate concrete by hand or power-driven trowel.
 2. Continue troweling passes and restraighten until surface is free of trowel marks and uniform in texture and appearance.
 3. Grind smooth surface defects that would telegraph through applied coatings or floor coverings.
 4. Do not add water to concrete surface.
 5. Do not apply hard-troweled finish to concrete that has a total air content greater than 3 percent.
 6. Locations:
 - a. Surfaces exposed to view or to be covered with resilient flooring, carpet, ceramic tile set over a cleavage membrane, liquid floor treatments, and polished concrete finished floors.
- E. Trowel and Fine-Broom Finish:
1. While concrete is still plastic, slightly scarify surface with a fine broom.
 2. Coordinate required final finish with Architect before application.
 3. Comply with flatness and levelness tolerances for trowel-finished floor surfaces.
 4. Locations:
 - a. Surfaces indicated on Drawings and where ceramic tile is to be installed by either thickset or thinset method.
- F. Broom Finish:
1. Immediately after float finishing, slightly roughen trafficked surface by brooming with fiber-bristle broom perpendicular to main traffic route.
 2. Coordinate required final finish with Architect before application.
 3. Locations:
 - a. Exterior concrete platforms, steps, ramps, and where indicated on Drawings.

**NISQUALLY STATE PARK
NEW FULL SERVICE PARK – PHASE 2**

3.12 INSTALLATION OF MISCELLANEOUS CONCRETE ITEMS

A. Filling In:

1. Fill in holes and openings left in concrete structures after Work of other trades is in place unless otherwise indicated.
2. Mix, place, and cure concrete, as specified, to blend with in-place construction.
3. Provide other miscellaneous concrete filling indicated or required to complete Work.

B. Interior Curbs:

1. Provide monolithic finish to interior curbs by stripping forms while concrete is still green and by steel-troweling surfaces to a hard, dense finish with corners, intersections, and terminations slightly rounded.

C. Equipment Bases and Foundations:

1. Coordinate sizes and locations of concrete bases with actual equipment provided.
2. Construct concrete bases as indicated on Drawings, and extend base not less than 6 inches in each direction beyond maximum dimensions of supported equipment unless otherwise indicated or unless required for seismic anchor support.
3. Minimum Compressive Strength: 4,000 psi at 28 days.
4. Install dowel rods to connect concrete base to concrete floor. Unless otherwise indicated, install dowel rods on 18 inch centers around full perimeter of concrete base.
5. For supported equipment, install epoxy-coated anchor bolts that extend through concrete base and anchor into structural concrete substrate.
6. Prior to pouring concrete, place and secure anchorage devices.
 - a. Use setting drawings, templates, diagrams, instructions, and directions furnished with items to be embedded.
 - b. Cast anchor-bolt insert into bases.
 - c. Install anchor bolts to elevations required for proper attachment to supported equipment.

D. Steel Pan Stairs: Provide concrete fill for steel pan stair treads, landings, and associated items.

1. Cast-in inserts and accessories as shown on Drawings.
2. Screed, tamp, and trowel finish concrete surfaces.

3.13 CONCRETE CURING

A. Protect freshly placed concrete from premature drying and excessive cold or hot temperatures.

1. Comply with ACI 301 and ACI 306.1 for cold-weather protection.
2. Comply with ACI 301 and ACI 305.1 for hot-weather protection during curing.
3. Maintain moisture loss no more than 0.2 lb/sq. ft. x h before and during finishing operations.
4. Apply evaporation retarder immediately after placing concrete if necessary to maintain maximum moisture loss.

**NISQUALLY STATE PARK
NEW FULL SERVICE PARK – PHASE 2**

B. Curing Formed Surfaces: Comply with ACI 308.1 as follows:

1. Cure formed concrete surfaces, including underside of beams, supported slabs, and other similar surfaces.
2. If forms remain during curing period, moist cure after loosening forms.
3. If removing forms before end of curing period, continue curing for remainder of curing period, as follows:
 - a. Continuous Fogging: Maintain standing water on concrete surface until final setting of concrete.
 - b. Continuous Sprinkling: Maintain concrete surface continuously wet.
 - c. Absorptive Cover: Pre-dampen absorptive material before application; apply additional water to absorptive material to maintain concrete surface continuously wet.
 - d. Water-Retention Sheeting Materials: Cover exposed concrete surfaces with sheeting material, taping, or lapping seams.
 - e. Membrane-Forming Curing Compound: Apply uniformly in continuous operation by power spray or roller in accordance with manufacturer's written instructions.
 - 1) Recoat areas subject to heavy rainfall within 3 hours after initial application.
 - 2) Maintain continuity of coating and repair damage during curing period.

C. Curing Unformed Surfaces: Comply with ACI 308.1:

1. Begin curing immediately after finishing concrete by one or a combination of the following methods:
 - a. Absorptive Cover: As soon as concrete has sufficient set to permit application without marring concrete surface, install prewetted absorptive cover over entire area of floor.
 - 1) Lap edges and ends of absorptive cover not less than 12 inches.
 - 2) Maintain absorptive cover water saturated, and in place, for duration of curing period, but not less than 7 days.
 - b. Moisture-Retaining-Cover Curing: Cover concrete surfaces with moisture-retaining cover for curing concrete, placed in widest practicable width, with sides and ends lapped at least 12 inches, and sealed by waterproof tape or adhesive.
 - 1) Immediately repair holes or tears during curing period, using cover material and waterproof tape.
 - 2) Cure for not less than 7 days.
 - c. Ponding or Continuous Sprinkling of Water:
 - 1) Maintain concrete surfaces continuously wet for not less than 7 days utilizing water or continuous water-fog spray.
 - d. Applications:
 - 1) Surfaces to receive floor coverings specified in other Sections.
 - 2) Surfaces to receive penetrating liquid floor treatments.

**NISQUALLY STATE PARK
NEW FULL SERVICE PARK – PHASE 2**

- 3) Surfaces to receive polished finish.
 - a) Do not use moisture-retaining-cover curing for surfaces to receive polished finish.

2. Floors to Receive Curing Compound:

- a. Apply uniformly in continuous operation by power spray or roller according to manufacturer's written instructions.
- b. Recoat areas subjected to heavy rainfall within 3 hours after initial application.
- c. Maintain continuity of coating and repair damage during curing period.
- d. Removal: After curing period has elapsed, remove curing compound without damaging concrete surfaces by method recommended by curing compound manufacturer unless manufacturer certifies curing compound does not interfere with bonding of floor covering used on Project.
- e. Applications:
 - 1) Interior surfaces schedule to receive floor covering adhesives.
 - 2) Do not apply to slabs scheduled to receive polished concrete finishing.

3. Floors to Receive Curing and Sealing Compound:

- a. Apply uniformly to floors and slabs indicated in a continuous operation by power spray or roller according to manufacturer's written instructions.
- b. Recoat areas subjected to heavy rainfall within 3 hours after initial application.
- c. Repeat process 24 hours later and apply a second coat.
 - 1) Maintain continuity of coating and repair damage during curing period.
- d. Applications:
 - 1) Exposed exterior surfaces including sidewalks and equipment pads.
 - 2) Do not use on interior slabs unless indicated otherwise.
 - 3) Do not apply to slabs scheduled to receive polished concrete finishing.

3.14 TOLERANCES

- A. Finish surfaces to the following tolerances, in accordance with ASTM E1155, for a randomly trafficked floor surface:
 1. Slabs on Ground, Floor Areas Less Than 10,000 Sq. Ft.:
 - a. Finish and measure surface so gap at any point between concrete surface and an unlevelled, freestanding, 10 ft. long straightedge resting on 2 high spots and placed anywhere on surface does not exceed 1/4 inch, or 1/16 inch in 2 feet where gauged porcelain tile is scheduled.
 2. Slabs on Ground, Floor Areas Greater Than 10,000 Sq. Ft.:

**NISQUALLY STATE PARK
NEW FULL SERVICE PARK – PHASE 2**

- a. Slabs Scheduled to Receive Carpeting: Specified overall values of flatness, F_F 25; and of levelness, F_L 20; with minimum local values of flatness, F_F 17; and of levelness, F_L 15.
 - b. Slabs Scheduled to Polished Concrete Finishing: Specified Overall Value (SOV): F_F 50 and F_L 25 with minimum local value (MLV): F_F 40 and F_L 17.
3. Suspended Slabs, Floor Areas Less Than 10,000 Sq. Ft.:
- a. Finish and measure surface so gap at any point between concrete surface and an unlevelled, freestanding, 10 ft long straightedge resting on 2 high spots and placed anywhere on surface does not exceed 1/4 inch, or 1/16 inch in 2 feet where gauged porcelain tile is scheduled.
4. Suspended Slabs, Floor Areas Greater Than 10,000 Sq. Ft.:
- a. Slabs Scheduled to Receive Carpeting: Specified overall values of flatness, F_F 25; and of levelness, F_L 20; with minimum local values of flatness, F_F 17; and of levelness, F_L 15.
- B. Floor Levelness Exceptions:
1. May be waived by Architect if not practical at specific locations.
 2. Floor levelness requirements are not applicable at slabs sloped to drain.

3.15 APPLICATION OF LIQUID FLOOR TREATMENTS

- A. Penetrating Liquid Floor Treatment (Type-1): Prepare, apply, and finish penetrating liquid floor treatment according to manufacturer's written instructions.
1. Remove curing compounds, sealers, oil, dirt, laitance, and other contaminants and complete surface repairs using a fully automatic floor scrubber with 100 grit sanding screens.
 2. Do not apply to concrete that is less than 28 days old.
 3. Apply liquid until surface is saturated, scrubbing into surface until a gel forms; rewet; and repeat brooming or scrubbing.
 4. Rinse with water; remove excess material until surface is dry.
 5. Apply a second coat in a similar manner if surface is rough or porous.
 6. Applications:
 - a. Type-1: Interior slabs on ground that are scheduled to remain exposed.
 - b. Type-2: Interior slabs on ground that are scheduled to receive adhered flooring materials.

3.16 JOINT FILLING

- A. Prepare, clean, and install joint filler according to manufacturer's written instructions.
1. Defer joint filling until concrete has aged as follows:

**NISQUALLY STATE PARK
NEW FULL SERVICE PARK – PHASE 2**

- a. Semi-Rigid Joint Fillers: Minimum 1 month.
 - b. Joint Sealants Specified in Section 079200: Minimum 6 months.
2. Do not fill joints until construction traffic has permanently ceased.
- B. Remove dirt, debris, saw cuttings, curing compounds, and sealers from joints; leave contact faces of joints clean and dry.
- C. Install semi-rigid joint filler full depth in saw-cut joints and at least 2 inches deep in formed joints.
- D. Overfill joint and trim joint filler flush with top of joint after hardening.
- 3.17 CONCRETE SURFACE REPAIRS
- A. Defective Concrete:
1. Repair and patch defective areas when approved by Architect.
 2. Remove and replace concrete that cannot be repaired and patched to Architect's approval.
- B. Patching Mortar:
1. Mix dry-pack patching mortar, consisting of 1 part portland cement to 2-1/2 parts fine aggregate passing a No. 16 sieve, using only enough water for handling and placing.
- C. Repairing Formed Surfaces: Surface defects include color and texture irregularities, cracks, spalls, air bubbles, honeycombs, rock pockets, fins and other projections on surface, and stains and other discolorations that cannot be removed by cleaning.
1. Immediately after form removal, cut out honeycombs, rock pockets, and voids more than 1/2 inch in any dimension to solid concrete.
 - a. Limit cut depth to 3/4 inch.
 - b. Make edges of cuts perpendicular to concrete surface.
 - c. Clean, dampen with water, and brush-coat holes and voids with bonding agent.
 - d. Fill and compact with patching mortar before bonding agent has dried.
 - e. Fill form-tie voids with patching mortar or cone plugs secured in place with bonding agent.
 2. Repair defects on surfaces exposed to view by blending white portland cement and standard portland cement so that, when dry, patching mortar matches surrounding color.
 - a. Patch a test area at inconspicuous locations to verify mixture and color match before proceeding with patching.
 - b. Compact mortar in place and strike off slightly higher than surrounding surface.
 3. Repair defects on concealed formed surfaces that affect concrete's durability and structural performance as determined by Architect.
- D. Repairing Unformed Surfaces:

**NISQUALLY STATE PARK
NEW FULL SERVICE PARK – PHASE 2**

1. Test unformed surfaces, such as floors and slabs, for finish and verify surface tolerances specified for each surface.
 - a. Correct low and high areas.
 - b. Test surfaces sloped to drain for trueness of slope and smoothness; use a sloped template.
2. Repair finished surfaces containing defects, including spalls, popouts, honeycombs, rock pockets, crazing and cracks in excess of 0.01 inch wide or that penetrate to reinforcement or completely through unreinforced sections regardless of width, and other objectionable conditions.
3. After concrete has cured at least 14 days, correct high areas by grinding.
4. Correct localized low areas during or immediately after completing surface finishing operations by cutting out low areas and replacing with patching mortar.
 - a. Finish repaired areas to blend into adjacent concrete.
5. Correct other low areas scheduled to receive floor coverings with a repair underlayment.
 - a. Prepare, mix, and apply repair underlayment and primer according to manufacturer's written instructions to produce a smooth, uniform, plane, and level surface.
 - b. Feather edges to match adjacent floor elevations.
6. Correct other low areas scheduled to remain exposed with a repair topping.
 - a. Cut out low areas to ensure a minimum repair topping depth of 1/4 inch to match adjacent floor elevations.
 - b. Prepare, mix, and apply repair topping and primer according to manufacturer's written instructions to produce a smooth, uniform, plane, and level surface.
7. Repair defective areas, except random cracks and single holes 1 inch or less in diameter, by cutting out and replacing with fresh concrete.
 - a. Remove defective areas with clean, square cuts and expose steel reinforcement with at least a 3/4 inch clearance all around.
 - b. Dampen concrete surfaces in contact with patching concrete and apply bonding agent.
 - c. Mix patching concrete of same materials and mixture as original concrete, except without coarse aggregate.
 - d. Place, compact, and finish to blend with adjacent finished concrete.
 - e. Cure in same manner as adjacent concrete.
8. Repair random cracks and single holes 1 inch or less in diameter with patching mortar.
 - a. Groove top of cracks and cut out holes to sound concrete and clean off dust, dirt, and loose particles.
 - b. Dampen cleaned concrete surfaces and apply bonding agent.
 - c. Place patching mortar before bonding agent has dried.
 - d. Compact patching mortar and finish to match adjacent concrete.
 - e. Keep patched area continuously moist for at least 72 hours.

**NISQUALLY STATE PARK
NEW FULL SERVICE PARK – PHASE 2**

E. Perform structural repairs of concrete, subject to Architect's approval, using epoxy adhesive and patching mortar.

1. Repair materials and installation not specified above may be used, subject to Architect's written approval.

3.18 FIELD QUALITY CONTROL

A. Special Inspections: Owner will engage a special inspector and qualified testing and inspecting agency to perform field tests and inspections and prepare test reports.

B. Testing Agency: Owner will engage a qualified testing and inspecting agency to perform tests and inspections and to submit reports.

1. Testing agency shall be responsible for providing curing container for composite samples on Site and verifying that field-cured composite samples are cured in accordance with ASTM C31.
2. Testing agency shall immediately report to Architect, Contractor, and concrete manufacturer any failure of Work to comply with Contract Documents.
3. Testing agency shall report results of tests and inspections, in writing, to Owner, Architect, Contractor, and concrete manufacturer within 48 hours of inspections and tests.

a. Test reports shall include reporting requirements of ASTM C31, ASTM C39, and ACI 301, including the following as applicable to each test and inspection:

- 1) Project name.
- 2) Name of testing agency.
- 3) Names and certification numbers of field and laboratory technicians performing inspections and testing.
- 4) Name of concrete manufacturer.
- 5) Date and time of inspection, sampling, and field testing.
- 6) Date and time of concrete placement.
- 7) Location in Work of concrete represented by samples.
- 8) Date and time sample was obtained.
- 9) Truck and batch ticket numbers.
- 10) Design compressive strength at 28 days.
- 11) Concrete mixture designation, proportions, and materials.
- 12) Field test results.
- 13) Information on storage and curing of samples before testing, including curing method and maximum and minimum temperatures during initial curing period.
- 14) Type of fracture and compressive break strengths at seven days and 28 days.

C. Batch Tickets: For each load delivered, submit 3 copies of batch delivery ticket to testing agency, indicating quantity, mix identification, admixtures, design strength, aggregate size, design air content, design slump at time of batching, and amount of water that can be added at Project site.

D. Inspections:

1. Inspect formwork for shape, location, and dimensions of concrete member being formed.

**NISQUALLY STATE PARK
NEW FULL SERVICE PARK – PHASE 2**

2. Steel-reinforcement placement.
 3. Steel-reinforcement mechanical splice couplers.
 4. Steel-reinforcement welding.
 5. Headed bolts and studs.
 6. Verification of use of required design mixture.
 7. Concrete placement, including conveying and depositing.
 8. Curing procedures and maintenance of curing temperature.
 9. Verification of concrete strength before removal of shores and forms from beams and slabs.
 10. Batch Plant Inspections: On a random basis, as determined by Architect.
- E. Concrete Testing: Perform testing of composite samples of fresh concrete obtained in accordance with ASTM C172 according to the following requirements:
1. Testing Frequency: Obtain at least 1 composite sample for each 150 cu. yd. or fraction thereof of each concrete mixture placed each day.
 2. Testing Frequency: Obtain 1 composite sample for each day's pour of each concrete mixture exceeding 5 cu. yd., but less than 25 cu. yd., plus 1 set for each additional 50 cu. yd. or fraction thereof.
 - a. When frequency of testing provides fewer than 5 compressive-strength tests for each concrete mixture, testing shall be conducted from at least 5 randomly selected batches or from each batch if fewer than 5 are used.
 3. Slump: ASTM C143:
 - a. 1 test at point of placement for each composite sample, but not less than 1 test for each day's pour of each concrete mixture.
 - b. Perform additional tests when concrete consistency appears to change.
 4. Slump Flow: ASTM C1611:
 - a. 1 test at point of placement for each composite sample, but not less than 1 test for each day's pour of each concrete mixture.
 - b. Perform additional tests when concrete consistency appears to change.
 5. Air Content: ASTM C231, pressure method, for normal-weight concrete:
 - a. 1 test for each composite sample, but not less than 1 test for each day's pour of each concrete mixture.
 6. Concrete Temperature: ASTM C1064:
 - a. 1 test hourly when air temperature is 40 deg F and below or 80 deg F and above, and 1 test for each composite sample.
 7. Compression Test Specimens: ASTM C31.
 - a. Cast and laboratory cure 2 sets of 3 standard cylinder specimens for each composite sample.

**NISQUALLY STATE PARK
NEW FULL SERVICE PARK – PHASE 2**

- b. Cast, initial cure, and field cure 2 sets of 3 standard cylinder specimens for each composite sample.
 - 8. Compressive-Strength Tests: ASTM C39:
 - a. Test 1 set of 2 laboratory-cured specimens at 7 days and 1 set of 2 specimens at 28 days or 56 days, depending on mix strength and curing requirements indicated on structural Drawings.
 - b. Test 1 set of 3 field-cured specimens at 7 days and 1 set of 2 specimens at 28 days or 56 days, depending on mix strength and curing requirements indicated on structural Drawings.
 - c. A compressive-strength test shall be the average compressive strength from a set of 3 specimens obtained from same composite sample and tested at age indicated.
 - 9. When strength of field-cured cylinders is less than 85 percent of companion laboratory-cured cylinders, evaluate operations and provide corrective procedures for protecting and curing in-place concrete.
 - 10. Strength of each concrete mixture will be satisfactory if every average of any 3 consecutive compressive-strength tests equals or exceeds specified compressive strength, and no compressive-strength test value falls below specified compressive strength by more than 500 psi if specified compressive strength is 5,000 psi, or no compressive strength test value is less than 10 percent of specified compressive strength if specified compressive strength is greater than 5,000 psi.
 - 11. Nondestructive Testing: Impact hammer, sonoscope, or other nondestructive device may be permitted by Architect but will not be used as sole basis for approval or rejection of concrete.
 - 12. Additional Tests:
 - a. Testing and inspecting agency shall make additional tests of concrete when test results indicate that slump, air entrainment, compressive strengths, or other requirements have not been met, as directed by Architect.
 - b. Testing and inspecting agency may conduct tests to determine adequacy of concrete by cored cylinders complying with ASTM C42 or by other methods as directed by Architect.
 - 1) Acceptance criteria for concrete strength shall be in accordance with ACI 301 section 1.6.6.3.
 - 13. Additional testing and inspecting, at Contractor's expense, will be performed to determine compliance of replaced or additional Work with specified requirements.
 - 14. Correct deficiencies in Work that test reports and inspections indicate do not comply with Contract Documents.
- F. Measure floor and slab flatness and levelness according to ASTM E1155 within 48 hours of finishing and promptly report test results to Architect.
- 3.19 PROTECTION
- A. Protect concrete surfaces scheduled to remain exposed until Substantial Completion.

**NISQUALLY STATE PARK
NEW FULL SERVICE PARK – PHASE 2**

- B. Protect concrete surfaces scheduled to receive finished flooring until installation of floor coverings.
- C. Protect concrete surfaces as follows:
 - 1. Petroleum stains.
 - 2. Diaper hydraulic equipment used over concrete surfaces.
 - 3. Liquid floor treatment from damage and wear during remainder of construction period.
 - a. Use protective methods and materials, including temporary covering, recommended in writing by liquid floor treatments applicator.
 - 4. Concrete surfaces scheduled to receive surface hardener and polished concrete finish using Floor Slab Protective Covering.
- D. Prohibit the following:
 - 1. Vehicles from interior concrete slabs.
 - 2. Use of pipe-cutting machinery over concrete surfaces.
 - 3. Placement of steel items on concrete surfaces.
 - 4. Use of acids or acidic detergents over concrete surfaces.

END OF SECTION

**NISQUALLY STATE PARK
NEW FULL SERVICE PARK – PHASE 2**

SECTION - 033010 – CEMENT CONCRETE PAVING

PART 1 - GENERAL

1.1 SECTION INCLUDES

- A. The work described in this section applies to Cement Concrete Pavement A, B, C, D, and E, Cement Concrete Thickened Edge, Concrete Steps, and Concrete Ramp. Contractor is informed Cement Concrete Paving B & C are unique surfaces intended to replicate natural riverbed conditions. Contractor shall deploy skilled, experienced, and artistic concrete labor and supervision personnel to achieve intended outcomes. Furnish materials, labor, transportation, services, and equipment necessary to furnish and install the work as indication on drawings and specified herein.

1.2 RELATED WORK

- A. Coordinate related work specified in other parts of the Project Specifications, including, but not limited to the following:
 - 1. Section 031000 – Concrete Forming and Accessories
 - 2. Section 032000 – Concrete Reinforcing
 - 3. Section 033000 – Cast-in-Place Concrete
 - 4. Section 033020 - Lithomosaic
 - 5. Section 312000 – Earth Moving
 - 6. Section 321500 – Crushed Rock Surfacing
 - 7. Section 321600 – Curbs and Gutters

1.3 REQUIREMENTS OF REGULATORY AGENCIES

- A. Federal, State and local laws and regulations governing this Work are hereby incorporated into and made part of this Section. When this Section calls for certain materials, workmanship, or a level of construction that exceeds the level of Federal, State, or local requirements, provisions of this Section take precedence.

1.4 REFERENCES

- A. Specifications and recommended practices of American Concrete Institute (ACI), American Society for Testing and Materials (ASTM), The Uniform Building Code, and U.S. Patents (#4,748,788, #6,6033,146, #6,016,635 and U.S. Trademark #1,873,329) referred to in this Specification with their individual designations are to be considered part of this Specification.
- B. Design and Control of Concrete Mixtures – Thirteenth Edition; Portland Cement Association.

**NISQUALLY STATE PARK
NEW FULL SERVICE PARK – PHASE 2**

1.5 QUALITY ASSURANCE

- A. All concrete work shall be done with extreme care by a company specializing in cast-in-place concrete with a minimum of 10 years of documented experience. Any work which does not conform to the construction documents shall be rejected, removed, and redone.
- B. Engage experienced personnel who have completed at least three (3) completed installations of similar scope and complexity using this application, material, design, and extent indicated for this Project.
- C. Submit resumes of Concrete Foreman and two installers/finishers that will be performing the installation.
- D. Single Source Responsibility: Obtain each color, type, and variety of materials from a single source with resources to provide products and materials of consistent quality in appearance and physical properties without delaying work.
- E. Testing:
 - 1. The Owner's testing firm will take cylinders and perform slump, compression strength, and air entrainment tests in accordance with ACI 301. Provide Testing Lab with 24 hours' notice.
- F. Contractor is informed that only the highest quality workmanship will be accepted.
- G. Pre-installation Conference: Conduct conference at Project site to comply with requirements in Division 01 Section "Project Meetings."
 - 1. Before submitting design mixtures, review concrete design mixture and examine procedures for ensuring quality of concrete materials. Require representatives of each entity directly concerned with cast-in-place concrete to attend, including the following:
 - a. Contractor's superintendent.
 - b. Independent testing agency responsible for concrete design mixtures.
 - c. Ready-mix concrete manufacturer.
 - d. Concrete subcontractor.
 - e. Installer and manufacturer's representative for sealer/hardener/densifier.
 - 2. Review special inspection and testing and inspecting agency procedures for field quality control, concrete finishes and finishing, cold- and hot-weather concreting procedures, curing procedures, construction expansion and isolation joints, and joint-filler strips, semirigid joint fillers, forms and form removal limitations, steel reinforcement installation, concrete repair procedures, finishes, and concrete protection.

1.6 SITE INSPECTION

- A. Verify conditions at site that affect work of this Section.
- B. Take field measurements as required.

**NISQUALLY STATE PARK
NEW FULL SERVICE PARK – PHASE 2**

- C. Report major discrepancies between Drawings and field dimensions to Owner's Authorized Representative prior to commencing work.

1.7 SUBMITTALS

- A. Product Data: Submit product data as required and as specified in Section 013300 Submittal Procedures. Include joint filler data, admixtures, and curing compound information. Submit a list of products specified in this section, no later than 10 days after contract award.
- B. Submit Design Mix: Low slump as specified. Batch history provided for each mix.
- C. Mock-Ups: Prepare mock-ups per section 013300 Submittal Procedures. Prepare the following mock-ups illustrating specified textured finish and color admixture as required. Approved Mock-up may remain in place as finished product. Rejected Mock-ups shall be removed.
 - 1. Natural Color Portland Cement, Cement Concrete Paving A with one saw cut joint, one expansion joint, and with Medium Broom Finish.
 - 2. Cement Concrete Paving D with one saw cut joint, one expansion joint, and with a Heavy Broom Finish Wave Pattern.
 - 3. Cement Concrete Paving E with one saw cut joint, one expansion joint, and with a Medium Broom Finish.
 - 4. Cement Concrete Paving B, and C with one saw cut joint and one expansion joint and with specified finish.
 - 5. Cement Concrete Steps with specified finish.
 - 6. Cement Concrete Ramp with specified finish.
 - 7. Mock-ups shall remain as sample to match throughout project and shall be a minimum of 12' wide and 12' long with one expansion joint at center. Make up to two mock-ups to meet Landscape Architect's requirements.
- D. Shop Drawings: Submit shop drawings for reinforcing steel and accessories in accordance with ACI standards.
 - 1. Paving Jointing and Pour Sequence Plan - submit electronic file indicating the following:
 - a. Proposed layout of expansion and control joints. Clearly delineate the different joint types.
 - b. Layout of paving types as indicated on Drawing Paving Schedule. Give overall dimensions of each paving type.
 - c. Concrete pour sequence. Indicated sequence of paving pour installation.
- E. Statement of Mix Design: Submit (1) copy of Statement of Mix Design prepared by batch plant servicing Project for each load delivered to Project. Statement of Mix Design to contain following information:
 - 1. Name, address, and telephone number of batch plant preparing statement of mix design.
 - 2. Date of mix design.
 - 3. Project location.
 - 4. Contractor requesting load delivery.
 - 5. Mix design number.
 - 6. Integral color used.

**NISQUALLY STATE PARK
NEW FULL SERVICE PARK – PHASE 2**

7. Gradations for sand and aggregate.
8. Material weights, specific gravity, and absolute volumes.
9. Basis of testing, i.e., UBC 2605 D4 and Title 24 2604 D4.
10. Water/cement ratio.
11. PSI rating.
12. Signature of testing laboratory manager.
13. Signed stamp from registered Project structural engineer or architect.

1.8 REFERENCE STANDARDS

- A. All work shall comply with Jurisdiction's Standard Drawings and Washington State Department of Transportation Standard Specifications (WSDOTSS).
- B. All exterior cement concrete pavement surfacing shall comply with ADA Standards for Accessible Design, Ground and Floor Surfaces per latest addition of Code of Regulations by the Department of Justice.

1.9 TESTING

- A. A testing agency will be designated by Owner. Contractor shall provide Testing Agency with 120 hours' notice of testing.

1.10 PROJECT CONDITIONS

- A. Keep Work area clean, and in a safe and workmanlike condition so that rubbish, waste and debris do not interfere with work of other trades.

1.11 PRODUCT HANDLING

- A. Store materials in a dry and protected location. Protect reinforcing steel from rusting, deformation, staining, and moisture damage.

PART 2 - PRODUCTS

2.1 MATERIALS

- A. Cement: Conform to "Specifications for Portland Cement" ASTM C150-68, Type I or Type II, Class 4000. Do not use different cements or different brands of cement interchangeably in the same element or portion of the work; use one brand and color of cement for all exposed concrete.
- B. Aggregates: Conform to "Specifications for Concrete Aggregates" ASTM C 33-69. Fine and coarse aggregates shall be regarded as separate ingredients. Each size of coarse aggregate, as well as the combination of sizes when two or more are used, shall conform to the grading requirements of the appropriate ASTM specifications.

**NISQUALLY STATE PARK
NEW FULL SERVICE PARK – PHASE 2**

- C. Water: Mixing water shall be clean and free from injurious amounts of oil, acids, alkalis, salts, organic materials, or other substances that may be deleterious to concrete or steel.

2.2 HAND SEEDED AGGREGATE (HSA) & HAND SEEDED COBBLE (HSC)

- A. Hand Seeded Aggregate & Cobble shall be clean, naturally occurring water rounded gravel material. Clean, hard, and durable aggregate shall be round to sub-angular, non-fractured stone. Fractured and angular aggregates from quarries, ledge rock, and talus slopes are not acceptable. Hand Seeded Aggregate & Cobble shall originate from local sources and range in color. Submit 5 gallon bucket sample for written approval. Hand Seeded Aggregate and Cobbles shall meet the following gradation and test requirements:

HSA for Cement Concrete Paving B

Approximate Size Note 1	Percent Passing
2"	100
1 1/2"	80
1"	60
3/4"	40

HSC for Cement Concrete Paving C

Approximate Size Note 1	Percent Passing
4"	100
3"	80
2"	60
1 1/2"	40
1"	30
3/4"	20

Aggregate Property	Test Method	Requirement
Degradation Factor	WSDOT T 113	15 min
Los Angeles Wear, 500 Rec.	AASHTO T 96	50% max.
Bulk Specific Gravity	AASHTO T 85	2.55

The grading of the Hand Seeded Aggregate & Cobble shall be determined by Landscape Architect by visual inspection of the load before it is dumped on site, or, if so ordered by Landscape Architect, by dumping on a flat surface and sorting and measuring the individual rocks contained in the load.

Note 1: Approximate size is determined by taking the average dimension of the three axes of the aggregate: length, width and thickness by use of the following calculation. Length is the longest axis; width is the second longest axis and thickness is the shortest axis.

$$\text{Length} + \text{Width} + \text{Thickness} / 3 = \text{Approximate Size}$$

- B. Hand Seeded Aggregate & Cobble from same source shall be used for each paving pour specified throughout entire project.

**NISQUALLY STATE PARK
NEW FULL SERVICE PARK – PHASE 2**

2.3 PROPORTIONING

- A. General: Concrete for all parts of the work shall be homogeneous and when hardened, shall have the required strength, resistance to abrasion, watertightness, appearance, resistance to deterioration, durability, and other properties specified herein.
- B. Slump: Slump for concrete as determined by "Method of Test for Slump of Portland Cement Concrete" ASTM C 143-69, shall be 2-4 inches.

Make one test for each batch of concrete and at least one test per hour during a continuous pour.

- C. Aggregate Size: Maximum size of the aggregate is 3/4" but not larger than one-fifth of the narrowest dimension between sides of forms, one-third of the depth of slabs, or three-fourths of the minimum clear distance between reinforcing bars and side forms. See structural drawings for other requirements.
- D. Admixtures:
 - 1. Air-Entraining Admixtures, Pozzolanic Materials, and Proprietary Chemical Admixtures: Use in accordance with manufacturer's recommendations. All admixtures must be compatible with one another.
 - 2. Rheocrete 222+ or other Owner-approved corrosion-inhibiting admixture will be used in all concrete with reinforcing steel. Admixture must provide both passive and active protection of reinforcing steel. Rheocrete 222+ shall be used at a dosage rate of one gallon/cubic yard of concrete.
 - 3. Air-entraining admixture will comply with ASTM C260 and be certified by manufacturer to be compatible with other required admixtures.
 - 4. Water-reducing admixture will comply with ASTM C494, Type A, and be certified.
- E. Proportion of Ingredients: Proportion ingredients to produce the proper playability, durability, and strength. Proportion ingredients to produce a mixture which will work readily into the corners and angles of the forms, and around reinforcement by the methods of placing and consolidation employed on the work, but without permitting the materials to segregate, or excessive free water to collect on the surface.

Strength Min. Cement Content (psi)	Minimum Sacks per Cu. Yd.
4,000	6-Paving

The minimum cement contents above may be reduced by 1/2 sack per cubic yard when an approved water reducing additive is used.

- F. Fly Ash: Use one sack Fly Ash per cubic yard, must comply with ASTM C618, Type F.
- G. Integral Color for Cement Concrete Pavement B, C, and D only shall be Sandstone CC730/3 by Euclid Chemical, www.euclid.com, 1.800.752.4626. Integral Color shall be added to the concrete mix at the concrete mixing source (Plant) to proportions defined by Euclid Chemical and shall be consistent with every single Cement Concrete Pavement B, C, and D concrete mix.

**NISQUALLY STATE PARK
NEW FULL SERVICE PARK – PHASE 2**

2.4 MIXING

- A. Standards: Mix and transport ready-mixed concrete in accordance with "Specifications for Ready-Mixed Concrete" ASTM C 94-69.
- B. Slump: Mix concrete only in quantities for immediate use. Do not make indiscriminate addition of water to increase slump. When concrete arrives at the project with slump below that suitable for placing, water may be added only if the maximum permissible water-cement ratio or the maximum slump is not exceeded, and only at the direction of the Owner.
- C. Temperatures: The as-mixed concrete temperature shall not be less than 55 degrees F when the ambient temperature falls below 40 degrees F. If water or aggregate has been heated, combine water with the aggregate in the mixer before cement is added when the temperature of the mixture is greater than 100 degrees F.

2.5 EXPANSION JOINT & MATERIALS

- A. Joint Filler: ASTM D1752, Type I; closed cell isometric polymeric foam, resilient recovery of 95% if not compressed more than 50% of original thickness; ½” thick “Ceramar”, manufactured by W.R. Meadows or approved equal.
- B. Expansion Joint Cap: Removable, high-impact extruded polystyrene, placed on joint filler during concrete placement; removed after curing to expose ½” deep sealant trough of covered dimensions; “Joint Cap” by the Burke Company or approved equal.
- C. Premilled expansion joint filler shall be of sufficient size to cover the full depth of the concrete section. Joints shall be 1/2" thick. Provide removable plastic cap (zip-strip) to hold joint filler below concrete surface. Refer to locations shown on the drawings.
- D. Joint Sealant w/ Sand Topping: ASTM D5893/D5893M-16 Cold-Applied, Single Component, Chemically Curing Silicone Joint Sealant; product shall be Pourthane SL Self-Leveling Polyurethane Joint Sealant, manufactured by W.R. Meadows.
 - 1. Sand topping for the joint sealant shall comply with ASTM-C144

2.6 REINFORCEMENT

- A. Per Section 032000 – Concrete Reinforcing.

PART 3 - EXECUTION

3.1 SUBGRADE

- A. Subgrade to meet requirements of project’s Earthwork section.
- B. Ensure that subbase and subgrade is compacted to 95 percent prior to placing concrete.

**NISQUALLY STATE PARK
NEW FULL SERVICE PARK – PHASE 2**

- C. Ensure that utilities, including irrigation lines and sleeves are buried and compacted below bottom of subbase.
- D. Keep subbase damp prior to placing concrete. Compact subgrade to 95% of maximum density as determined by ASTM D-1557-M.

3.2 FORMWORK

- A. General: Reference Section 031000 – Concrete Forming and Accessories. Landscape Architect and Contractor shall verify all formwork grades prior to pouring. Obtain Landscape Architect's approval of formwork before placing concrete. All curves shall have a consistent radii and vertical grade, straight tangents shall unwavering in the horizontal and vertical alignment.
- B. Contractor is required to measure all formwork to laser level accuracy and shall provide a laser level on site for the O.R. to use to check grades.

3.3 TOLERANCES

- A. The top of the finished concrete shall not deviate more than one-eighth inch (1/8") in ten feet (10'), or the alignment one-fourth inch (1/4") in ten feet (10').

3.4 CONCRETE FINISHES

- A. Concrete Thickness: 4 or 6 inches, as indicated in Drawings, except at thickened edge.
- B. Medium Broom Finish: Pull broom across freshly floated concrete to produce rough texture in East/West direction of the concrete panels. Texture created shall be 1/32-inch to 3/64-inch in depth.
- C. Coarse Broom Finish Wave Pattern: Pull broom across freshly floated concrete to produce rough texture in a wave pattern that runs parallel to the aggregate streambed pattern of the concrete panels, example as shown in drawings. Texture created shall be 3/64-inch to 1/8-inch in depth.
- D. Sandblast Finish: sandblast concrete slab surface to light sandblast finish to match approved sand blasted mock-up sample panel. Exact alignment and width of sandblasted area will follow plans and shall be modified by Landscape Architect in field. Feathering of sandblasting edge shall transition from Cement Concrete Paving D wave pattern to full exposed aggregate texture in Cement Concrete Paving B and C and as directed by Landscape Architect.
- E. Cement Concrete Paving D Finishing: This concrete pavement will have the coarse broom finish wave pattern that runs parallel to the aggregate streambed pattern of Cement Concrete Paving B.
- F. Cement Concrete Paving B finishing: This concrete pavement type is designed to replicate the successive, depositional patterns of a shoreline with the waterside of the deposit layer washed, exposing gravel. Verify alignment with Landscape Architect.

**NISQUALLY STATE PARK
NEW FULL SERVICE PARK – PHASE 2**

Center of pour will receive a higher concentration of larger aggregate with the outer part of pour receiving a heavy broom finish wave pattern, see drawings for layout. Hand select and seed aggregate as described in plans to achieve a heavy to light aggregate distribution pattern from center to outside. Hand seed aggregate so flat side of rock is exposed and flush or slightly higher than adjacent concrete grade. No aggregate shall be exposed more than one quarter inch higher than the adjacent concrete grade or stone.

Contractor shall achieve a transition, textural gradation from a coarse texture at center of pour to Broom finish at outer pour, as shown in drawings. Contractor shall define method and obtain approval from Landscape Architect.

Edge all concretes with 1/2" radius edger.

G. Cement Concrete Paving C

Cement Concrete Paving C is intended to replicate a Western Washington stream bottom with riffles formed by cobbles (Hand Seeded Aggregate & Cobbles) Place Hand Seeded Aggregate & Cobbles to form stream features. Hand select Aggregate & Cobbles to assure all aggregate will be a variable height / depth per Landscape Architect's direction.

H. Cement Concrete Paving A, Steps, and Ramp

Finish for Cement Concrete Paving A and Ramps shall be a medium broom finish with brush strokes perpendicular to longitudinal slope.

Concrete finish for Step Tread and Risers shall be a medium broom finish with brush strokes perpendicular to step treads. Form safety step nosing with Safety Step Edger with 4/1/2"x6"x 1/2" R with (4) four 1/4" grooves (Masco model TEH SG4, Masco.net).

Stain for step nosing shall be a semi-transparent water based stain, approved brand ColorWave in the color, "Yellow". Apply stain and use a finishing seal per manufacturer recommendations.

I. Cement Concrete Paving E Finishing

Finish for Cement Concrete Paving E shall be a medium broom finish with brush strokes perpendicular to longitudinal slope.

3.5 CLEAN UP

- A. Contractor shall clean up and remove all concrete spatters and spray evidence on other site improvements immediately. All evidence of excess concrete disposed on site shall be removed from project site within 48 hours of pour.
- B. Clean up entire area of all excess materials, debris, etc., and leave project in a neat, orderly condition.

END OF SECTION

**NISQUALLY STATE PARK
NEW FULL SERVICE PARK – PHASE 2**

SECTION – 033020 - LITHOMOSAIC

PART 1 - GENERAL

1.1 DESCRIPTION

- A. The work described in this section applies to LithoMosaic® as implemented in Cement Concrete Paving D on Overlook 2. An image of the mosaic design is provided as Attachment A at the end of this section. The electric file of the mosaic design shall be provided by the Owner upon Contractor request per Section 013600 – Digital File Request Form.

1.2 SCOPE OF WORK

- A. Furnish materials, labor, transportation, services, and equipment necessary to furnish and install Lithomosaic® architectural concrete paving as indicated on the drawings and as specified herein.
- B. Work included in this Section:
 - 1. Only experienced Architectural Cast-in-place Concrete installers certified to install Lithomosaic® are acceptable for this project. For certified Lithomosaic® installers contact Lithocrete™ at 800-899-9921.
 - 2. A Lithomosaic example can be review at West Bay Public Plaza in Olympia, WA, which was installed by Belarde Company Inc. Contact Belarde Company Inc., Johnna Belarde at 425-376-2500.

1.3 RELATED SECTIONS

- A. Section 033010 – Cement Concrete Paving
- B. Section 133700 – Boardwalk

1.4 REQUIREMENTS OF REGULATORY AGENCIES

- A. Federal, State and local laws and regulations governing this Work are hereby incorporated into and made part of this Section. When this Section calls for certain materials, workmanship, or a level of construction that exceeds the level of Federal, State, or local requirements, provisions of this Section take precedence.

**NISQUALLY STATE PARK
NEW FULL SERVICE PARK – PHASE 2**

1.5 APPLICABLE STANDARDS

- A. Specifications and recommended practices of American Concrete Institute (ACI), American Society for Testing and Materials (ASTM), the International Building Code, and under one or more U.S. Patents 5,794,401; 5,887,339; 5,950,394; 6,016,635; 6,033,146; 6,082,074; 6,112,487; 7,322,772; 7,493,732; 7,607,859; 7,614,820; 7,670,081; 7,781,019 and U.S. Trademarks #1,879,329, # 2,358,183 # 2,358,054 referred to in this Specification with their individual designations are to be considered part of this Specification.
- B. Design and Control of Concrete Mixtures – Thirteenth Edition; Portland cement Association.

1.6 QUALITY CONTROL

- A. Quality control to be maintained by licensed installers of LithoMosaic® throughout duration of project.
- B. Paving Subcontractor Qualifications: provide evidence to indicate successful experience in providing LithoMosaic® similar to that specified herein.
- C. As part of the bid submittal the General Contractor shall submit background information and/or qualifications on his Architectural Cast-in-place Contractor certified for Lithomosaic® installation. This information shall provide evidence to indicate successful experience in providing concrete work identical to that specified herein. A listing of projects shall be provided and shall be reviewed and approved as comparable projects to the specified work by the Owner or Landscape Architect prior to award of bid. Failure to provide this information or the submittal of incomplete or inaccurate information shall give cause to reject the entire bid as non-responsive and incomplete.
- D. Demonstration of experience: provide a minimum of three (3) projects of installed Lithomosaic® totaling at least 1,000 square feet with a reference list of each containing address of installation, contact person and phone number of project's architect or Owner's representation. Minimum size of each individual installation shall be 200 square feet. Provide two (2) color photos, 8" x 10" size, of each installation listed above representing the installation. Photo #1 shall show the approximate size of the installation. Photo #2 shall be taken approximately 2 to 3 feet from the paving surface. See submittals portion of this section for additional information.
- E. Supervision: On site superintendent must have a minimum of 10 years' experience installing Lithomosaic®.
- F. Slip Resistance: provide a finish with a slip resistance of equal or greater than 0.65 when tested by the Owner in accordance with ASTM F 489.

1.7 SITE INSPECTION

- A. Verify conditions at site that affect work of this Section.
- B. Take field measurements as required.

**NISQUALLY STATE PARK
NEW FULL SERVICE PARK – PHASE 2**

- C. Report major discrepancies between Drawings and field dimensions to Owner's Authorized Representative prior to commencing work.

1.8 SUBMITTALS

- A. Product Data: Submit no later than 10 days after contract award a typed list of products specified in this Section.
- B. Shop Drawings:
 - 1. Submit shop drawings for reinforcing steel and accessories in accordance with ACI standards.
 - 2. Paving Jointing and Pour Sequence Plan - submit six blueprints indicating the following:
 - a. Proposed layout of contraction, construction and isolation joints. Clearly delineate the three different joint types.
 - b. Layout of paving types as indicated on Drawing Paving Schedule. Give overall dimensions of each paving type.
 - c. Concrete pour sequence. Indicated sequence of paving pour installation.
- C. Statement of Mix Design: Submit (1) copy of Statement of Mix Design prepared by batch plant servicing Project for each load delivered to Project. Statement of Mix Design to contain following information:
 - 1. Name, address, and telephone number of batch plant preparing statement of mix design.
 - 2. Date of mix design.
 - 3. Project location.
 - 4. Contractor requesting load delivery.
 - 5. Mix design number.
 - 6. Integral color used.
 - 7. Gradations for sand and aggregate.
 - 8. Material weights, specific gravity, and absolute volumes.
 - 9. Basis of testing, i.e. UBC 2605 D4 and Title 24 2604 D4.
 - 10. Water/cement ratio.
 - 11. PSI rating.
 - 12. Signature of testing laboratory manager.
 - 13. Signed stamp from registered Project structural engineer or architect.
- D. Submit evidence of licensed installer qualifications for experience, demonstration of square footage installed, number of projects, and contact information to verify experience as indicated in Quality Control section of this specification.
- E. Submit the full range of color and sizes of tiles and stones and glass proposed to be installed. Each color and size of tiles and stones shall submitted in half gallon zip-loc bags.

1.9 SUBSTITUTIONS

- A. None allowed unless approved in writing by Owner's Authorized Representative.

**NISQUALLY STATE PARK
NEW FULL SERVICE PARK – PHASE 2**

1.10 TESTING

- A. A testing agency may be designated by Owner or Owner's Authorized Representative. Testing personnel to meet ASTM E329 requirements.

1.11 MOCK-UPS

- A. Prior to construction, provide (1) 4-foot x 4-foot x 4-inch sample of the LithoMosaic® paving specified by Owner's artist.
- B. Ensure that each mock-up contains joint types specified on project, i.e. construction, contraction, and isolation.
- C. Locate mock-ups in a conveniently accessible and protected place. Approved mock-ups will be standard for future LithoMosaic® installation review.
- D. Mock-up may become a part of the finished work if approved by Owner and Landscape Architect.
- E. Remove mock-ups from site upon completion of Work and approval by Owner's Authorized Representative.

1.12 PROJECT CONDITIONS

- A. Keep Work area clean, and in a safe and workmanlike condition so that rubbish, waste and debris do not interfere with work of other trades.

1.13 PRODUCT HANDLING

- A. Store materials in a dry and protected location. Protect reinforcing steel and dowels from rusting, deformation, staining, and moisture damage.
- B. Keep LithoMosaic® materials dry at all times prior to installation.

1.14 COORDINATION

- A. Notify Owner's Authorized Representative and contractors performing work related to installation of Contractor's Work in ample time, so as to allow sufficient time for them to perform their portion of work.

1.15 LITHOMOSAIC

- A. Contractor shall retain an Artist who shall have experience in ceramic and stone mosaic paving work. Contractor shall submit 5 photographic samples of Artist ceramic and stone mosaic work embedded into concrete to Owner. Owner shall provide written approval/rejection of Contractor proposed Artist.

**NISQUALLY STATE PARK
NEW FULL SERVICE PARK – PHASE 2**

PART 2 - PRODUCTS

2.1 TILES AND STONES

- A. Submit one pound sample of all colors and sizes of tiles and stones proposed. Obtain written permission from Landscape Architect prior to ordering. Tiles and Stones shall be of uniform depth with a depth variation no greater than 1/4".

2.2 CONCRETE

- A. LithoMosaic® will be embedded into Cement Concrete Paving D on Overlook 2. Refer to Section 033010 Cement Concrete Paving and 133700 Boardwalk.

PART 3 - EXECUTION

- 3.1 Conduct Pre-Installation Conference with Landscape Architect prior to any LithoMosaic® ordering of materials, design, and work.

3.2 LITHOMOSAIC INSTALLATION

- A. Conduct Pre-Installation conference prior to any LithoMosaic® work.
- B. LithoMosaic® mosaic shall be installed in Cement Concrete Paving D at Overlook 2, as indicated on Plans. Mosaic shall be wet set in pavement surfaces and set flush with prevailing grade. Mosaic shall not be a mortar set over a concrete slab.
- C. LithoMosaic® is a patented paving process. Installation of LithoMosaic® must be performed by a licensed LithoMosaic® installer only.
- D. Contact Lithocrete® at 800-899-9921 for a licensed LithoMosaic® installer in project area.
- E. LithoMosaic® process incorporates use of following patented products:
 - 1. Lithocrete® Conditioner™.
 - 2. Lithocrete Etch Retarder®.
 - 3. Lithoseal paving sealer.
 - 4. Lithocrete® vibrating float process – use patent # 6,016,635
 - 5. Lithocrete® power trowel process – use patent # 6,016,635
- F. All LithoMosaic® mosaic shall be fabricated and installed to be ADA compliant.
- G. Contractor is responsible for all installation, curing, and sealing of LithoMosaic® mosaic.

**NISQUALLY STATE PARK
NEW FULL SERVICE PARK – PHASE 2**

3.3 JOINTING

- A. Refer to ACI 302 “Guide for Concrete Floor and Slab Construction” for work under this section.
- B. Construction and Contraction Joints:
 - 1. Saw-cut construction and contraction joints in locations indicated on Drawings.
 - 2. Perform jointing with a new diamond tip circular saw.
 - 3. Joint Width: Per Drawings. Do not exceed 3/16-inch in width.
 - 4. Depth of sawcuts: 1/4th depth of slab.
 - 5. Decorative Saw-cut Joints: Per Drawing.
 - 6. Saw-cut joints in a straight line with no over-cutting.
 - 7. Use a hand tool to saw-cut up to vertical edges such as walls, steps, curbs and columns. No cutting into vertical surfaces will be allowed.

3.4 CURING

- A. After LithoMosaic® exposure, cure concrete for seven (7) days without foot traffic and thirty (30) days without vehicular traffic.

3.5 SEALING

- A. Seal surface of mosaic paving using LithoMosaic® Sealer or HLQ 125. The application of hydrolyzed alkali silica solution inhibits the chemical reaction and resulting derogation inherent with seeding glass or organic materials such as seashells and metals into concrete.
- B. Follow LithoMosaic® Sealer directions when applying this product (sealer must be applied in 3 to 6 coats).

3.6 ACCEPTANCE OF WORK

- A. Contractor shall expect to cooperatively work with Landscape Architect to achieve intended outcomes. LithoMosaic® contains natural materials as installed by skilled laborers and supervisory personnel as well as the Artist in concert with the artistic vision of the Owner’s Representative; final acceptance is at the sole discretion of the Owner.

3.7 CLEANING

- A. Clean up debris and unused or excess material and remove from the site. Completely remove all concrete, mud, dirt and other substances from Work.
- B. All excess concrete shall be disposed of off-site.
- C. Touch-up, repair or replace damaged to Work before Substantial Completion.

NISQUALLY STATE PARK
NEW FULL SERVICE PARK – PHASE 2

ATTACHMENT A

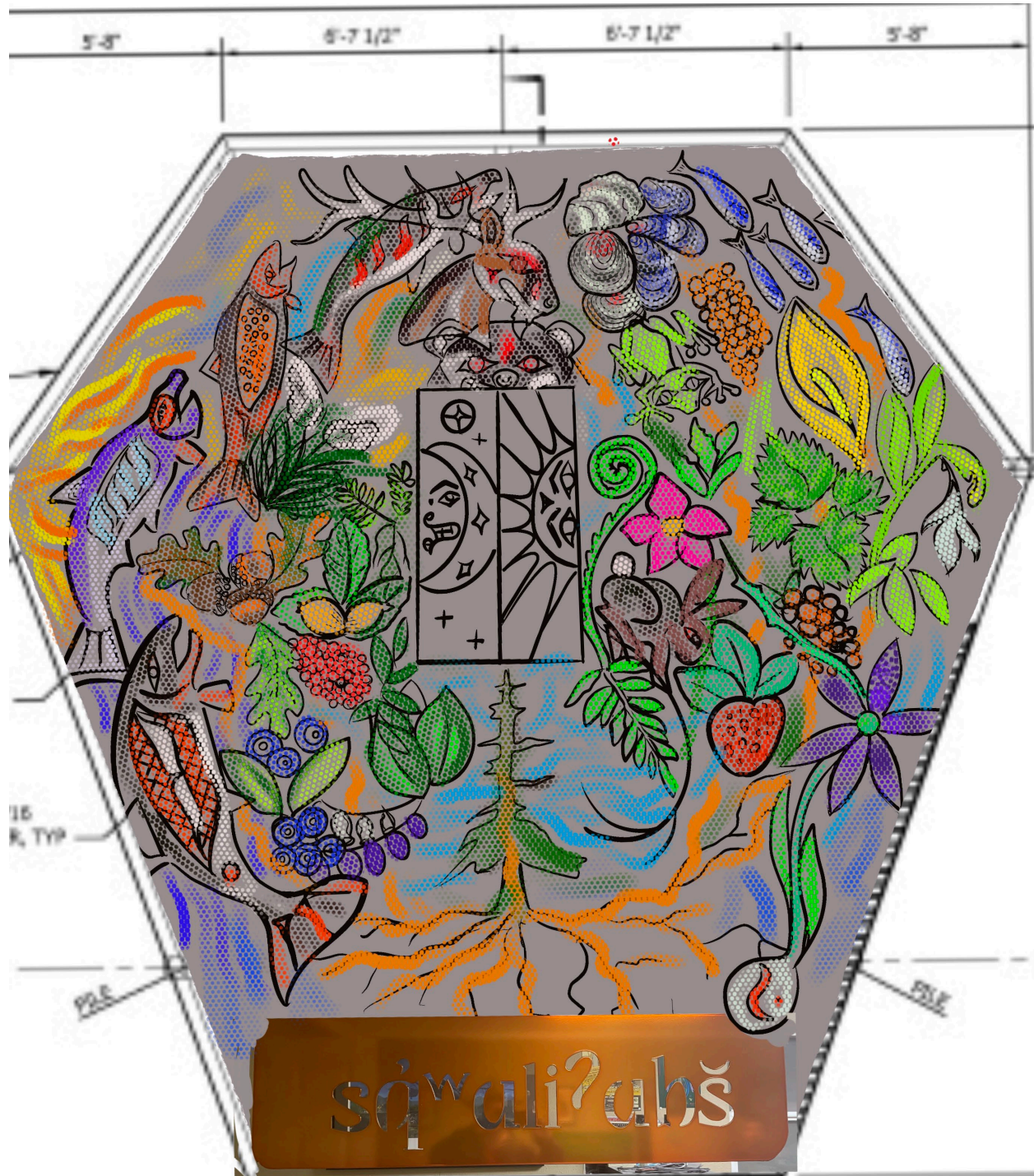

END OF SECTION

**NISQUALLY STATE PARK
NEW FULL SERVICE PARK – PHASE 2**

SECTION 033543 – POLISHED CONCRETE FINISHING

PART 1 - GENERAL

1.1 SUMMARY

A. Section Includes:

1. Polished concrete finishing.

B. Related Requirements:

1. Section 033000 Cast-in-Place Concrete, for concrete related to polished concrete, including concrete materials, mixture design, placement procedures, initial finishing, and curing.

1.2 DEFINITIONS

A. Terminology and Finish Gloss as defined by Concrete Polishing Council (CPC).

B. Bonded Abrasive Polished Concrete: Multi-step operation of mechanically grinding, honing, and polishing of a concrete floor surface with bonded abrasives to cut a concrete floor surface and to refine each cut to maximum potential to achieve a specified level of finished gloss as defined by the CPC.

C. CPC: Concrete Polishing Council. An organization that supports concrete floor polishing industry through position statements, specifications, seminars, webinars, and online training, and that offers consensus-based definitions, procedures, and best practices to suit every polished concrete surface.

D. Design Reference Sample: Sample designated by Architect in Contract Documents that reflects acceptable surface quality and appearance of polished concrete.

E. Finished Gloss: Processing a concrete floor surface to achieve a specified level of finished gloss prior to application of protective treatments.

1. Reflective Clarity: DOI (distinction of image) value of degree of sharpness and crispness of reflection of overhead objects when measured by a device in accordance to ASTM D5767. Value indicated is prior to application of sealer.
2. Reflective Sheen: Specular gloss value of degree of gloss reflected from a surface, at specified angles of illumination, when measured by a device in accordance to ASTM D523. Value indicated is prior to application of sealer.

F. Grout: Thin mortar used to fill surface imperfections including holes, surface damage, small and micro cracks, air holes, pop-outs, and voids to eliminate micro pitting in finished Work.

G. Polished Concrete: The act of changing a concrete floor surface to achieve a specified level of gloss.

**NISQUALLY STATE PARK
NEW FULL SERVICE PARK – PHASE 2**

1.3 ADMINISTRATIVE REQUIREMENTS

A. Coordination:

1. Schedule Work and coordinate troweling of concrete finish and curing of concrete slab with Work of Section 033000 Cast-in-Place Concrete.
2. Do not permit use of curing compounds on slabs receiving Work of this Section.
3. Do not permit use of fiber reinforcing in slabs receiving Work of this Section.

B. Preinstallation Meeting: Conduct meeting at Project site.

1. Meeting Time: Schedule meeting a minimum of 2 weeks prior to beginning Work of this Section and related Work.
2. Attendees: Owner, Architect, Contractor, Contractor's superintendent, independent testing agency responsible for concrete design mixtures, ready-mix concrete manufacturer, cast-in-place concrete Subcontractor, polished concrete finishing Subcontractor, polished concrete system manufacturer's trained technical representative, and other entities as requested to attend.
3. Before submitting design mixtures, review concrete design mixture and examine procedures for ensuring quality of concrete materials.
4. Review cold- and hot-weather concreting procedures, curing procedures, construction joints, concrete finishing, and protection of polished concrete.
5. Discuss floor protection plan.
6. Discuss procedures for cleaning up slab spills, including use of and availability of cleaning chemicals and absorptive materials.

1.4 ACTION SUBMITTALS

A. Product Data: For each type of product.

1. Include for each grinding machine, including types of grinding heads, dust extraction system, joint fillers, concrete densifying impregnators, penetrating sealer, and other chemicals used in the process.

B. Polishing Schedule: Submit plan layout showing polished concrete surfaces and schedule of polishing operations for each area of polished concrete before start of polishing operations. Include locations of all joints, including construction joints.

C. Samples for Verification: For each type of exposed finish.

D. Manufacturer's Instructions: Application instruction, special procedures, and conditions requiring special attention.

1.5 INFORMATIONAL SUBMITTALS

A. Qualification Data: For Installer.

1. Include certification of Installer's experience.

**NISQUALLY STATE PARK
NEW FULL SERVICE PARK – PHASE 2**

B. Material Certificates: For each of the following, signed by manufacturers:

1. Repair materials.
2. Stain materials.
3. Liquid floor treatments.

1.6 QUALITY ASSURANCE

A. Installer's Qualifications: Firm with not less than 3 years of experience in grinding and polishing of concrete flooring similar in complexity to Work required for this Project, including specific requirements indicated.

1. Successfully completed not less than 5 comparable scale projects using this equipment.
2. Factory trained or approved by system manufacturer for concrete preparation, toppings, grinding, and polishing work, with factory-trained supervisor on site during concrete floor polishing operations.

B. Supervisor Qualifications: Current certification from Concrete Polishing Council (CPC) stating that technicians are certified as Craftsmen Level II or higher.

C. Field Samples:

1. Build field samples approximately 50 sq. ft. for each concrete finish and sheen specified.
 - a. Field sample may be built at an area of slab that will subsequently be covered by carpet, provided that slab area is from same concrete mix and pour as areas scheduled for polished concrete finish.
 - b. Build field samples before casting concrete.
 - c. Build field samples in conjunction with concrete slab field samples specified Section 033000 Cast-in-Place Concrete.
2. Use specular gloss meter and coefficient of friction testing equipment as required to verify accepted gloss level and coefficient of friction.
3. Demonstrate curing, finishing, and protecting of polished concrete. Approval of system will be based on aesthetic compliance for the following:
 - a. Approved submittals.
 - b. Specified finished gloss level.

1.7 FIELD CONDITIONS

A. Traffic Control: Maintain access for pedestrian traffic as required for other construction activities.

B. Ambient Conditions:

1. Maintain temperatures recommended by polished flooring manufacturer.

**NISQUALLY STATE PARK
NEW FULL SERVICE PARK – PHASE 2**

1.8 DELIVERY, STORAGE, AND HANDLING

- A. Deliver materials to Project site in factory sealed containers, clearly labeled and marked with manufacturer's name, address, batch number, and date of manufacture.
- B. Store materials per manufacturer's printed instructions. Store materials to be used in conjunction with application of system indoors, protect from damage, and maintain at temperatures no lower than 40 deg F.

1.9 FIELD CONDITIONS

- A. Ambient Conditions:
 - 1. Proceed with installation only when existing and forecasted weather conditions permit polished concrete Work to be performed according to manufacturer's written instructions and warranty requirements.

1.10 WARRANTY

- A. Special Warranty: Provide Installer's "single source" warranty to repair or replace concrete finish damaged due to Installers' neglect, poor workmanship, or other warranted failures.
 - 1. Warranty Period: 1 year from date of Substantial Completion.

PART 2 - PRODUCTS

2.1 PERFORMANCE CRITERIA

- A. Floor Surface Profile: Prior to beginning concrete polishing Work, test floor surfaces according to ASTM E1155 to verify flatness and levelness requirements as specified in Section 033000 Cast-in-Place Concrete for concrete floor slab flatness and levelness.
 - 1. Floor levelness requirements may be waived by Architect if not practical at specific locations.
 - 2. Floor levelness requirements are not applicable at slabs sloped to drain.
- B. Design Criteria: The following gloss levels are based on CPC Polished Concrete Appearance Chart:
 - 1. Level 2, Satin (Honed): Images of objects being reflected have a matte appearance.
 - a. Image Clarity Value, Percent: 10-39.

**NISQUALLY STATE PARK
NEW FULL SERVICE PARK – PHASE 2**

2.2 POLISHED FLOOR FINISHING SYSTEMS

- A. Polished concrete finishing systems that include hardener-densifiers and stain and wear protection finish coats.
1. Products: Subject to compliance with requirements, provide one of the following:
 - a. ARDEX Americas:
 - 1) Sealer and Densifier: ARDEX PC 50 Lithium Densifier.
 - 2) Finish Sealer: ARDEX PC Finish.
 - b. Advanced Floor Products, Inc.: Retro-Plate 99.
 - 1) Sealer and Densifier: Retro-Plate 99.
 - 2) Finish Sealer: RetroGuard.
 - c. Laticrete International, Inc.: FGS Permashine.
 - 1) Sealer and Densifier: FGS Hardener Plus.
 - 2) Finish Sealer: Permaguard SPS.
 - d. Sika Corporation: Scofield Formula One.
 - 1) Sealer and Densifier: Scofield Formula One Lithium Densifier MP.
 - 2) Finish Sealer: Scofield Formula One Guard-W.
 - e. W.R. Meadows, Inc.: Induroshine.
 - 1) Sealer and Densifier: Liqui-Hard Ultra.
 - 2) Finish Sealer: Bellatrix.

2.3 ACCESSORIES

- A. Stain Protection Sealer: Ready to use, low odor, VOC compliant, stain and food resistant penetrating concrete sealer that meets slip-resistance according to ASTM D2407 and stain-resistance according to ASTM D1308.
1. Product: Subject to compliance with requirements, provide stain protection sealer that is acceptable to polished concrete finish manufacturer and applicator.
- B. Floor Protection Cover: Heavy-Duty, impact-resistant, vapor-permeable, flexible, multi-ply, textured membrane laminated with a non-woven polypropylene film acceptable to polished concrete finish product manufacturer and Installer.
1. Seaming Tape: Acceptable to floor protection product manufacturer.
- C. Joint Sealants: Acceptable to polished floor system manufacturer and applicator. Comply with requirements of Section 079200.

**NISQUALLY STATE PARK
NEW FULL SERVICE PARK – PHASE 2**

- D. Semi-Rigid Joint Filler (SR.JNT-1): 2-component, semi rigid, 100 percent solids, aromatic polyurea.
 - 1. Polyurea Products: Subject to compliance with requirements, provide one of the following:
 - a. ARDEX Americas: Ardiseal Rapid Plus.
 - b. Curecrete Distribution Inc.: CreteFill Pro 85.
 - c. Euclid Chemical Company (The): Euco Qwikjoint UVR.
 - d. Laticrete International, Inc.: L&M Joint Tite 750.
 - e. MAPEI Corporation: Planiseal RapidJoint 15.
 - f. Master Builders Solutions: MasterSeal CR 100.
 - g. Sika Corporation: Sika Loadflex-524 EZ.
 - h. Approved substitution.
- E. Grout: A thin mortar consisting of epoxy, urethane, polyurea, or polyaspartic resins or latex, acrylic, and silicate binders mixed with cement dust from previous grinding steps.
- F. Patching Mortar: Mix dry-pack patching mortar, consisting of 1 part portland cement to 2-1/2 parts fine aggregate passing a No. 16 sieve, using only enough water for handling and placing.

PART 3 - EXECUTION

3.1 PREPARATION

- A. Close areas to traffic during and after polished concrete application for a period of time recommended by polished flooring system manufacturer.
- B. Install barriers at adjacent building areas and cover adjacent construction to limit air-borne dust from settling on surfaces and entering adjacent areas.
- C. Mask adjoining surfaces not receiving polished finishing to prevent overspray, spillage, leaking, and migration of sealers.
- D. Remove protective coverings from concrete slab and thoroughly clean concrete surfaces to remove dirt, form oil, plaster, stains, oil, grease, adhesives, water repellants, compounds, and other substances that may deter penetration.
- E. Fill cracks, holes, and depressions in substrates with patching mortar and remove bumps and ridges to produce a uniform and smooth substrate prior to starting of grinding operations.

3.2 INITIAL GRINDING AND POLISHING APPLICATION

- A. Perform grinding, honing, and polishing procedures for dry grinding and honing according to recommendations from CPC.
- B. Scrub and rinse slab surface with clean water and vacuum with auto-scrubber between and after final passes.

**NISQUALLY STATE PARK
NEW FULL SERVICE PARK – PHASE 2**

- C. Perform sequential progression of diamond tooling steps and limit to no more than double the grit value of previous diamonds used.
- D. Overlap adjacent passes by 25 percent.
- E. Perform each pass perpendicular to subsequent pass; multiple passes may be needed.
- F. Progressively grind, hone, and polish slab surface utilizing approved diamond segments as necessary to produce finishing requirements, stopping at 1 polish level less than that specified for finished surface or as recommended by polished flooring applicator.
 - 1. Where necessary to fill gaps, voids, and pop-outs during grinding operation, apply patching mortar or grout coat according to manufacturer's recommendations.

3.3 CONCRETE SURFACE REPAIRS

- A. Mix patching mortar or grout material with dust created by grinding operations.
- B. Fill surface imperfections including holes, surface damage, small and micro cracks, air holes, pop-outs, and voids with patching mortar to eliminate micro pitting in finished Work.
- C. Using grinding equipment with appropriate grinding pad, work patching mortar and treatment into concrete surface and fill surfaces to eliminate imperfections.
 - 1. Repaired surface will be acceptable when there is no noticeable difference between existing and repaired surfaces when viewed from 10 feet away under lighting conditions that will be present after construction.
- D. Edges: In areas inaccessible to grinding equipment, use special hand-held or walk-behind edge grinding tool to perform polished finishing operations immediately following grinding equipment operations.
 - 1. Follow same steps and procedures as required for grinding equipment to match adjacent slab finish.

3.4 APPLICATION OF LIQUID FLOOR TREATMENTS

- A. Penetrating Liquid Floor Treatment: Apply undiluted liquid floor treatment material to slab to point of rejection using low-pressure spray keeping concrete surface wet for 5 to 15 minute period without producing puddles. Remove excess liquid and dispose in proper manner.
- B. Allow liquid floor treatment to gel and dry, then continue progressively polishing floor surface with resin diamonds as necessary to produce desired final finish.

**NISQUALLY STATE PARK
NEW FULL SERVICE PARK – PHASE 2**

3.5 POLISHING

A. Polish Finish:

1. Sheen Level Level 2; Low sheen, 400 grit or as indicated on Drawings.
2. Class: Class B – Fine Aggregate (Salt and Pepper Finish).

B. Polishing, General:

1. Process: Use dry grinding and polishing techniques.
 - a. Wet grinding and polishing is not acceptable.
2. Grinding Equipment: Use of electric machines required.
 - a. Propane-fueled equipment is not acceptable.
3. Apply polished concrete finish to ramps and vertical stair risers adjacent to and contiguous with slabs receiving polished concrete finishing.

C. Apply polished concrete finish system to cured and prepared slabs to match accepted field sample.

1. Machine grind floor surfaces to receive polished finishes level and smooth and to depth required to reveal aggregate to match approved field sample.
2. Apply penetrating liquid floor treatment for polished concrete in polishing sequence and according to manufacturer's written instructions, allowing recommended drying time between successive coats.
3. Continue polishing with progressively finer-grit diamond polishing pads to gloss level, to match approved field sample.
4. Control and dispose of waste products produced by grinding and polishing operations.
5. Neutralize and clean polished floor surfaces.

3.6 SEALING

A. After final polishing of surface, apply sealer at rates recommended by sealer manufacturer.

1. Apply to clean, dry slab at completion of mechanically polishing no higher than 800-grit. Ensure scratch pattern is not visible before application.
2. Lightly wet a lint free short nap paint roller with interior high performance sealer and remove excess, leaving primed paint roller.
3. Roll out sealer using minimal downward force. Evenly roll sealer without leaving overlap lines. Work from 1 control joint to another.
4. Maintain a thin, even coating and wet edge. Do not over apply.
5. If additional sealer is required to meet sheen approved in field sample, allow 4 to 6 hours of dry time before applying a second sealer coat.
6. To increase gloss, wait at least 12 to 24 hours after final coat is applied, then use a high- speed burnisher fitted with a burnishing pad. Burnish at a slow walking pace.

**NISQUALLY STATE PARK
NEW FULL SERVICE PARK – PHASE 2**

3.7 CLEANING

- A. Immediately clean up spills on slab. Provide cleaning chemicals and absorptive materials approved or recommended by polished concrete finishing products manufacturer and applicator.

3.8 PROTECTION

- A. Protect finished floors with temporary floor protection product to prevent damage including grinding and scratching by construction traffic and activities until Substantial Completion.
- B. Do not drag or drop equipment or material across slab that will cause damage to floor slab.
- C. Inspect tires for debris prior to use on slab. Remove embedded items that may cause damage to floor slab.
- D. Provide a clean slab surface using concrete maintenance cleaner within an auto scrubber, equipped with soft nylon brushes, in accordance with manufacturer's published recommendations.

END OF SECTION

**NISQUALLY STATE PARK
MAINTENANCE BUILDING PHASE 2**

SECTION 033900 – CONCRETE CURING AND SEALING

PART 1 - GENERAL

1.1 SCOPE OF WORK

- A. Initial and final curing of horizontal and vertical concrete surfaces.

1.2 RELATED SECTIONS

- A. Section 033000 – Cast-in-Place Concrete
- B. Section 033010 – Cement Concrete Paving
- C. Section 033020 – LithoMosaic

1.3 REFERENCES

- A. ACI 301 - Structural Concrete for Buildings.
- B. ACI 302 - Recommended Practice for Concrete Floor and Slab Construction.
- C. ACI 308 - Standard Practice for Curing Concrete.
- D. ASTM C171 - Sheet Materials for Curing Concrete.
- E. ASTM C309 - Liquid Membrane-Forming Compounds for Curing Concrete.
- F. ASTM D2103 - Polyethylene Film and Sheeting.

1.4 QUALITY ASSURANCE

- A. Perform Work in accordance with ACI 301.
- B. Deliver, store, protect, and handle products under provisions of WSDOTSS specifications, most recent edition at time of Bid applies.
- C. Deliver curing materials in manufacturer's packaging. Include application instructions.

1.5 SUBMITTALS

- A. Curing materials cut sheets.
- B. Curing materials application instructions.

**NISQUALLY STATE PARK
MAINTENANCE BUILDING PHASE 2**

- C. Curing materials MSDS (Material Safety Data Sheets).

PART 2 - PRODUCTS

2.1 MATERIALS

- A. Waterproof Paper Type C: ASTM C171, treated to prevent separation during handling and placing, standard color.
- B. Water: Potable, not detrimental to concrete.

PART 3 - EXECUTION

3.1 EXAMINATION

- A. Verify substrate conditions.
- B. Verify that substrate surfaces are ready to be cured.

3.2 EXECUTION - HORIZONTAL SURFACES

- A. Cure slab surfaces in accordance with ACI 308.
- B. Polyethylene Film: Spread over slab areas, lap edges and sides, seal with pressure sensitive tape; maintain in place for 7 days.

3.3 PROTECTION OF FINISHED WORK

- A. Protect finished Work under provisions of WSDOTSS specifications, most recent edition at time of Bid applies.
- B. Do not permit traffic over unprotected at-grade slab surface.

END OF SECTION

**NISQUALLY STATE PARK
NEW FULL SERVICE PARK – PHASE 2**

SECTION 042613 – MASONRY VENEER

PART 1 - GENERAL

1.1 SUMMARY

A. Section Includes:

1. Hollow brick.
2. Mortar.
3. Anchors.
4. Embedded flashing.
5. Miscellaneous masonry accessories.

B. Products Installed but not Furnished under This Section:

1. Steel lintels in masonry veneer.
2. Steel shelf angles for supporting masonry veneer.

1.2 ADMINISTRATIVE REQUIREMENTS

A. Preinstallation Meeting: Conduct meeting at Project site.

1.3 ACTION SUBMITTALS

A. Product Data: For each type of product.

B. Shop Drawings: For the following:

1. Masonry Units: Show sizes, profiles, coursing, and locations of special shapes.
2. Fabricated Flashing: Detail corner units, end-dam units, and other special applications.

C. Samples for Verification: For each type and color of the following:

1. Clay face brick, in the form of straps of 5 or more bricks.
2. Special brick shapes.
3. Pigmented mortar. Make Samples using same sand and mortar ingredients to be used on Project.
4. Weep holes and vents.
5. Accessories embedded in masonry.

**NISQUALLY STATE PARK
NEW FULL SERVICE PARK – PHASE 2**

1.4 INFORMATIONAL SUBMITTALS

- A. List of Materials Used in Constructing Sample Panels: List generic product names together with manufacturers, manufacturers' product names, model numbers, lot numbers, batch numbers, source of supply, and other information as required to identify materials used. Include mix proportions for mortar and grout and source of aggregates.
1. Submittal is for information only. Receipt of list does not constitute approval of deviations from Contract Documents unless such deviations are specifically brought to attention of Architect and approved in writing.
- B. Material Certificates: For each type and size of the following:
1. Masonry units.
 - a. Include data on material properties or material test reports substantiating compliance with requirements.
 - b. For brick, include size-variation data verifying that actual range of sizes falls within specified tolerances.
 - c. For exposed brick, include test report for efflorescence according to ASTM C67.
 2. Cementitious materials. Include name of manufacturer, brand name, and type.
 3. Mortar admixtures.
 4. Anchors and metal accessories.
- C. Mix Designs: For each type of mortar. Include description of type and proportions of ingredients.
1. Include test reports for mortar mixes required to comply with property specification. Test according to ASTM C109 for compressive strength, ASTM C1506 for water retention, and ASTM C91 for air content.
- D. Cold-Weather and Hot-Weather Procedures: Detailed description of methods, materials, and equipment to be used to comply with requirements.

1.5 QUALITY ASSURANCE

- A. Sample Panels:
1. Build sample panels for each type of exposed unit masonry construction in typical exterior wall in sizes approximately 96 inches long by 48 inches high by full thickness.
 2. Build sample panels facing south.
 3. Clean 1/2 of exposed faces of panels with masonry cleaner indicated.
 4. Protect approved sample panels from the elements with weather-resistant membrane.
 5. Approval of sample panels is for color, texture, and blending of masonry units; relationship of mortar and sealant colors to masonry unit colors; tooling of joints; aesthetic qualities of workmanship; and other material and construction qualities specifically approved by Architect in writing.

**NISQUALLY STATE PARK
NEW FULL SERVICE PARK – PHASE 2**

- a. Approval of sample panels does not constitute approval of deviations from Contract Documents contained in sample panels unless such deviations are specifically approved by Architect in writing.

1.6 DELIVERY, STORAGE, AND HANDLING

- A. Store masonry units on elevated platforms in a dry location. If units are not stored in an enclosed location, cover tops and sides of stacks with waterproof sheeting, securely tied. If units become wet, do not install until they are dry.
- B. Store cementitious materials on elevated platforms, under cover, and in a dry location. Do not use cementitious materials that have become damp.
- C. Store aggregates where grading and other required characteristics can be maintained and contamination avoided.
- D. Store masonry accessories, including metal items, to prevent corrosion and accumulation of dirt and oil.

1.7 FIELD CONDITIONS

- A. Protection of Masonry: During construction, cover tops of veneer, projections, and sills with waterproof sheeting at end of each day's Work. Cover partially completed masonry when construction is not in progress.
 - 1. Extend cover a minimum of 24 inches down face of veneer, and hold cover securely in place.
- B. Stain Prevention: Prevent grout, mortar, and soil from staining the face of masonry. Immediately remove grout, mortar, and soil that come in contact with masonry.
 - 1. Protect base of walls from rain-splashed mud and from mortar splatter by spreading coverings on ground and over wall surface.
 - 2. Protect sills, ledges, and projections from mortar droppings.
 - 3. Protect surfaces of window and door frames, as well as similar products with painted and integral finishes, from mortar droppings.
 - 4. Turn scaffold boards near the wall on edge at the end of each day to prevent rain from splashing mortar and dirt onto completed masonry.
- C. Cold-Weather Requirements: Do not use frozen materials or materials mixed or coated with ice or frost. Do not build on frozen substrates. Remove and replace unit masonry damaged by frost or by freezing conditions. Comply with cold-weather construction requirements contained in TMS 602.
 - 1. Cold-Weather Cleaning: Use liquid cleaning methods only when air temperature is 40 deg F and higher and will remain so until masonry has dried, but not less than 7 days after completing cleaning.
- D. Hot-Weather Requirements: Comply with hot-weather construction requirements contained in TMS 602.

**NISQUALLY STATE PARK
NEW FULL SERVICE PARK – PHASE 2**

PART 2 - PRODUCTS

2.1 MANUFACTURERS

- A. Source Limitations for Masonry Units: Obtain exposed masonry units of a uniform texture and color, or a uniform blend within ranges accepted for these characteristics, from single source from single manufacturer for each product required.
- B. Source Limitations for Mortar Materials: Obtain mortar ingredients of a uniform quality, including color for exposed masonry, from single manufacturer for each cementitious component and from single source or producer for each aggregate.

2.2 UNIT MASONRY, GENERAL

- A. Masonry Standard: Comply with TMS 602, except as modified by requirements in Contract Documents.
- B. Defective Units: Referenced masonry unit standards may allow a certain percentage of units to contain chips, cracks, or other defects exceeding limits stated. Do not use units where such defects are exposed in completed Work and will be within 20 feet vertically and horizontally of a walking surface.

2.3 BRICK

- A. Provide shapes indicated and as follows, with exposed surfaces matching finish and color of exposed faces of adjacent units:
 - 1. For ends of sills and caps and for similar applications that would otherwise expose unfinished brick surfaces, provide units without cores or frogs and with exposed surfaces finished.
 - 2. Provide special shapes for applications where stretcher units cannot accommodate special conditions, including those at corners, movement joints, bond beams, sashes, and lintels.
 - 3. Provide special shapes for applications requiring brick of size, form, color, and texture on exposed surfaces that cannot be produced by sawing.
 - 4. Provide special shapes for applications where shapes produced by sawing would result in sawed surfaces being exposed to view.
 - 5. Unit Compressive Strength: Provide units with minimum average net-area compressive strength of 3,350 psi.
- B. Brick: Hollow brick complying with ASTM C652, Class H40V.
 - 1. Manufacturer: Subject to compliance with requirements, provide the following:
 - a. Mutual Materials Co.: Kla-All Structural Brick
 - b. Approved substitution.
 - 2. ASTM C652: Grade: SW.
 - 3. ASTM C652: Type: HBS.
 - 4. Size (Actual Dimensions): As indicated on Drawings.

**NISQUALLY STATE PARK
NEW FULL SERVICE PARK – PHASE 2**

5. Collections: Kla-All.
6. Colors: Vintage and Redondo Gray.
7. Textures: Standard for specified brick.
8. Type: Stocking.
9. Application: Brick veneer on Admin building.

2.4 MORTAR MATERIALS

- A. Portland Cement: ASTM C150, Type I or II, except Type III may be used for cold-weather construction. Provide natural color or white cement as required to produce mortar color indicated.
 1. Alkali content shall not be more than 0.1 percent when tested according to ASTM C114.
- B. Hydrated Lime: ASTM C207, Type S.
- C. Portland Cement-Lime Mix: Packaged blend of portland cement and hydrated lime containing no other ingredients.
- D. Masonry Cement: Not allowed.
- E. Mortar Cement: ASTM C1329.
 1. Products: Subject to compliance with requirements, provide one of the following:
 - a. Blue Circle Cement: Magnolia Superbond Mortar Cement.
 - b. Lafarge North America Inc.: Lafarge Mortar Cement.
 - c. SPEC MIX, Inc.: Mortar Cement & Sand.
 - d. Approved substitution.
- F. Mortar Pigments: Natural and synthetic iron oxides and chromium oxides, compounded for use in mortar mixes and complying with ASTM C979. Use only pigments with a record of satisfactory performance in masonry mortar.
 1. Products: Subject to compliance with requirements, provide one of the following:
 - a. Davis Colors: True Tone Mortar Colors.
 - b. Euclid Chemical Company (The): Color-Crete Integral Color.
 - c. Solomon Colors, Inc.: SGS Concentrated A, H, and X Series Mortar Colors.
 - d. Approved substitution.
 2. Pigments shall not exceed 10 percent of portland cement by weight.
 3. Pigments shall not exceed 5 percent of mortar cement by weight.
- G. Aggregate for Mortar: ASTM C144.
 1. For mortar that is exposed to view, use washed aggregate consisting of natural sand or crushed stone.
 2. For joints less than 1/4 inch thick, use aggregate graded with 100 percent passing No. 16 sieve.
 3. White-Mortar Aggregates: Natural white sand or crushed white stone.

**NISQUALLY STATE PARK
NEW FULL SERVICE PARK – PHASE 2**

4. Colored-Mortar Aggregates: Natural sand or crushed stone of color necessary to produce required mortar color.
- H. Cold-Weather Admixture: Nonchloride, noncorrosive, accelerating admixture complying with ASTM C494, Type C, and recommended by manufacturer for use in masonry mortar of composition indicated.
 1. Products: Subject to compliance with requirements, provide one of the following:
 - a. Addiment Incorporated: Mortar Kick.
 - b. Euclid Chemical Company (The): Accelguard 80.
 - c. GCP Applied Technologies Inc.: Morset.
 - I. Water: Potable.

2.5 TIES AND ANCHORS

- A. Extend ties and anchors at least 1-1/2 inches into masonry and halfway through veneer, with at least a 5/8 inch cover on outside face.
- B. Materials: Provide ties and anchors specified in this Article that are made from materials that comply with the following unless otherwise indicated:
 1. Hot-Dip Galvanized, Carbon-Steel Wire: ASTM A82, with ASTM A153, Class B-2 coating.
 2. Galvanized-Steel Sheet: ASTM A653, Commercial Steel, G60 zinc coating.
 3. Steel Sheet, Galvanized after Fabrication: ASTM A1008, Commercial Steel, with ASTM A153, Class B coating.
 4. Steel Plates, Shapes, and Bars: ASTM A36.
- C. Adjustable Masonry-Veneer Anchors:
 1. Provide anchors that allow vertical adjustment but resist a 100 lbf load in both tension and compression perpendicular to plane of wall without deforming or developing play in excess of 1/16 inch.
 2. Fabricate sheet metal anchor sections and other sheet metal parts from 0.109 inch thick, stainless steel sheet.
 3. Fabricate wire ties from 0.187 inch diameter, stainless steel wire unless otherwise indicated.
 4. Masonry-Veneer Anchors; Double-Pintle Plate: Rib-stiffened, sheet metal anchor section with screw holes at top and bottom, projecting horizontal leg with slots for vertical legs of double pintle wire tie, and pronged punchouts that project from back of anchor.
 - a. Products: Subject to compliance with requirements, provide one of the following:
 - 1) Heckmann Building Products Inc.: 213 Wire Veneer Anchor System.
 - 2) Hohmann & Barnard, Inc.: HB-200-X.
 - 3) Wire-Bond: HCL-711 Anchoring System.
 - 4) Approved substitution.
 - b. Application: Brick veneer at metal stud walls.

**NISQUALLY STATE PARK
NEW FULL SERVICE PARK – PHASE 2**

5. Polymer-Coated, Steel Drill Screws for Steel Studs: ASTM C954 except manufactured with hex washer head and neoprene washer, No. 10 diameter by length required to penetrate steel stud flange with not less than 3 exposed threads, and with organic polymer coating with salt-spray resistance to red rust of more than 800 hours per ASTM B117.
 - a. Products: Subject to compliance with requirements, provide one of the following:
 - 1) ITW Buildex: Teks Maxiseal with Climaseal finish.
 - 2) Textron Inc.: Textron Fastening Systems; Elco Dril-Flex with Stalgard finish.
6. Stainless-Steel Drill Screws for Steel Studs: Fasteners made from Type 410 stainless steel or made with a carbon-steel drill point and 300 Series stainless-steel shank, complying with ASTM C954 except manufactured with hex washer head and neoprene or EPDM washer, No. 10 diameter by length required to penetrate steel stud flange with not less than 3 exposed threads.
 - a. Products: Subject to compliance with requirements, provide the following:
 - 1) ITW Buildex: Scots long life Teks.
 - 2) Wire-Bond: SFS Stadler SX Fastener.

2.6 EMBEDDED FLASHING

- A. Metal Flashing: Provide metal flashing complying with SMACNA's "Architectural Sheet Metal Manual and as follows:
 1. Stainless Steel: ASTM A240 or ASTM A666, Type 316, 0.0188 inch thick.
 2. Fabricate continuous flashings in sections 96 inches long minimum, but not exceeding 12 feet.
 - a. Provide splice plates at joints of formed, smooth metal flashing.
 3. Fabricate metal drip edges from stainless steel.
 - a. Extend at least 3 inches into wall and 1/2 inch out from wall, with outer edge bent down 30 degrees and hemmed.
 4. Locations: Where flashing is exposed to view and the following:
 - a. Where flashing is indicated to receive counterflashing, use metal flashing.
 - b. Where flashing is indicated to be turned down at or beyond wall face, use metal flashing.
 - c. Where flashing is partly exposed and is indicated to terminate at wall face, use metal flashing with a sealant stop with a drip edge.
- B. Flexible Flashing: Specified in Section 076500 – Flexible Flashing, for the following type:
 1. Rubberized-Asphalt Sheet Flashing: SA.FLSHG-3.
- C. Solder and Sealants for Sheet Metal Flashings: As specified in Section 076200 – Sheet Metal Flashing and Trim.

**NISQUALLY STATE PARK
NEW FULL SERVICE PARK – PHASE 2**

- D. Adhesives, Primers, and Seam Tapes for Flashings: Flashing manufacturer's standard products or products recommended by flashing manufacturer for bonding flashing sheets to each other and to substrates.
- E. Termination Bars for Flexible Flashing: 0.019 inch thick stainless steel sheet, 1-1/2 inches wide with a 3/8 inch sealant flange at top.

2.7 MISCELLANEOUS MASONRY ACCESSORIES

- A. Compressible Filler: Premolded, closed cell, neoprene filler strips complying with ASTM D1056, Grade 2A1; compressible up to 35 percent; of width and thickness indicated.
 - 1. Products: Subject to compliance with requirements, provide 1 of the following:
 - a. Blok-Lok; a Hohmann & Barnard company: NS Neoprene Sponge.
 - b. Hohmann & Barnard, Inc.: NS – Closed Cell Neoprene Sponge.
 - c. NMW, Inc.: Foamtech "N".
 - d. Williams Products, Inc.: Everlastic EVA-200G 1056 Joint Filler.
 - e. Wire-Bond: #3300 Expansion Joint.
- B. Weep Tubes: Round, plastic weep tubes with stainless steel screens and wicking material:
 - 1. Products: Subject to compliance with requirements, provide 1 of the following:
 - a. Advanced Building Products Inc.: Mortar Maze Weep Tubes.
 - b. Heckmann Building Products Inc.: No. 330 Weep Tubes.
 - c. Hohmann & Barnard, Inc.: 341 Series Round Plastic Weep Holes.
 - d. Masonpro, Inc.: Weep Tube with Wick and Screen.
 - e. Wire-Bond: #3600 Clear Round Weep Hole.
 - 2. Material: Clear medium-density polyethylene.
 - 3. Size: 3/8 inch OD by 4 inches long.
- C. Cavity Vents: 1-piece, cellular, honeycombed vent for embedding full height and width of head joint in masonry cavity wall mortar joints.
 - 1. Products: Subject to compliance with requirements, provide 1 of the following:
 - a. Advanced Building Products Inc.: Mortar Maze Weep Vent.
 - b. Heckmann Building Products Inc.: Cell Vent No. 85.
 - c. Hohmann & Barnard, Inc.: QV-Quadro-Vent.
 - d. Masonpro, Inc.: Standard or Utility Cell Vents.
 - e. Mortar Net Solutions: CellVent.
 - f. Wire-Bond: #3601 Cell Vent.
 - 2. Material: UV-resistant, high-density polypropylene.
 - 3. Sizes: 3/8 inch wide, 3-2/3 inch deep, height to match masonry head joint.
 - 4. Color: As selected by Architect from manufacturer's standard colors.

**NISQUALLY STATE PARK
NEW FULL SERVICE PARK – PHASE 2**

- D. Cavity Drainage Material: Free-draining mesh, made from polymer strands that will not degrade within wall cavity.
1. Products: Subject to compliance with requirements, provide 1 of the following:
 - a. Advanced Building Products Inc.: Mortar Break or Mortar Break II.
 - b. Hohmann & Barnard, Inc.: Mortar Web.
 - c. Mortar Net Solutions: Mortar Net.
 - d. Wire-Bond: #3611 Cavity Net.
 2. Configuration:
 - a. Strips, full-depth of cavity and 10 inches wide that prevent clogging with mortar droppings.

2.8 MASONRY CLEANERS

- A. Proprietary Acidic Cleaner: Manufacturer's standard-strength cleaner designed for removing mortar/grout stains, efflorescence, and other new construction stains from new masonry without discoloring or damaging masonry surfaces. Use product expressly approved for intended use by cleaner manufacturer and manufacturer of masonry units being cleaned.
1. Products: Subject to compliance with requirements, provide one of the following:
 - a. Diedrich Technologies, Inc.; a division of Hohmann & Barnard, Inc.: 202 New Masonry Detergent.
 - b. EaCo Chem, Inc.: NMD 80.
 - c. ProSoCo, Inc.: Sure Klean 600.
 - d. Approved substitution.

2.9 MORTAR MIXES

- A. Do not use admixtures, including pigments, air-entraining agents, accelerators, retarders, water-repellent agents, antifreeze compounds, or other admixtures unless otherwise indicated.
1. Do not use calcium chloride in mortar or grout.
 2. Use portland cement-lime mortar unless otherwise indicated.
 3. For exterior masonry, use portland cement-lime mortar.
 4. Add cold-weather admixture (if used) at same rate for mortar that will be exposed to view, regardless of weather conditions, to ensure that mortar color is consistent.
- B. Mortar for Unit Masonry: Comply with ASTM C270, Proportion Specification. Use Type N unless another type is indicated.
1. Type M: 2,500 psi; for masonry below grade or in contact with earth.
 2. Type S: 1,800 psi; for exterior, above-grade brick veneer.

**NISQUALLY STATE PARK
NEW FULL SERVICE PARK – PHASE 2**

- C. Pigmented Mortar: Use colored cement product or select and proportion pigments with other ingredients to produce color required. Do not add pigments to colored cement products.
 - 1. Pigments shall not exceed 10 percent of portland cement by weight.
 - 2. Pigments shall not exceed 5 percent of mortar cement by weight.
 - 3. Mix to match Architect's sample.
 - 4. Application: Use pigmented mortar for exposed mortar joints.

PART 3 - EXECUTION

3.1 EXAMINATION

- A. Examine conditions, with Installer present, for compliance with requirements for installation tolerances and other conditions affecting performance of Work.
 - 1. For the record, prepare written report, endorsed by Installer, listing conditions detrimental to performance of Work.
- B. Proceed with installation only after unsatisfactory conditions have been corrected.

3.2 INSTALLATION, GENERAL

- A. Thickness: Build cavity walls and other masonry construction to full thickness shown. Build singlewythe walls to actual widths of masonry units, using units of widths indicated.
- B. Leave openings for equipment to be installed before completing masonry. After installing equipment, complete masonry to match the construction immediately adjacent to opening.
- C. Use full-size units without cutting if possible. If cutting is required to provide a continuous pattern or to fit adjoining construction, cut units with motor-driven saws; provide clean, sharp, unchipped edges. Allow units to dry before laying unless wetting of units is specified. Install cut units with cut surfaces and, where possible, cut edges concealed.
- D. Select and arrange units for exposed unit masonry to produce a uniform blend of colors and textures. Mix units from several pallets or cubes as they are placed.
- E. Wetting of Brick: Wet brick before laying if initial rate of absorption exceeds 30 g/30 sq. in. per minute when tested according to ASTM C67. Allow units to absorb water so they are damp but not wet at time of laying.

3.3 TOLERANCES

- A. Dimensions and Locations of Elements:
 - 1. For dimensions in cross section or elevation, do not vary by more than plus 1/2 inch or minus 1/4 inch.

**NISQUALLY STATE PARK
NEW FULL SERVICE PARK – PHASE 2**

2. For location of elements in plan, do not vary from that indicated by more than plus or minus 1/2 inch.
3. For location of elements in elevation, do not vary from that indicated by more than plus or minus 1/4 inch in a story height or 1/2 inch total.

B. Lines and Levels:

1. For bed joints and top surfaces of bearing walls, do not vary from level by more than 1/4 inch in 10 feet, or 1/2 inch maximum.
2. For conspicuous horizontal lines, such as lintels, sills, parapets, and reveals, do not vary from level by more than 1/8 inch in 10 feet, 1/4 inch in 20 feet, or 1/2 inch maximum.
3. For vertical lines and surfaces, do not vary from plumb by more than 1/4 inch in 10 feet, 3/8 inch in 20 feet, or 1/2 inch maximum.
4. For conspicuous vertical lines, such as external corners, door jambs, reveals, and expansion and control joints, do not vary from plumb by more than 1/8 inch in 10 feet, 1/4 inch in 20 feet, or 1/2 inch maximum.
5. For lines and surfaces, do not vary from straight by more than 1/4 inch in 10 feet, 3/8 inch in 20 feet, or 1/2 inch maximum.
6. For vertical alignment of exposed head joints, do not vary from plumb by more than 1/4 inch in 10 feet or 1/2 inch maximum.
7. For faces of adjacent exposed masonry units, do not vary from flush alignment by more than 1/16 inch except due to warpage of masonry units within tolerances specified for warpage of units.

C. Joints:

1. For bed joints, do not vary from thickness indicated by more than plus or minus 1/8 inch, with a maximum thickness limited to 1/2 inch.
2. For exposed bed joints, do not vary from bed-joint thickness of adjacent courses by more than 1/8 inch.
3. For head and collar joints, do not vary from thickness indicated by more than plus 3/8 inch or minus 1/4 inch.
4. For exposed head joints, do not vary from thickness indicated by more than plus or minus 1/8 inch. Do not vary from adjacent bed-joint and head-joint thicknesses by more than 1/8 inch.
5. For exposed bed joints and head joints of stacked bond, do not vary from a straight line by more than 1/16 inch from one masonry unit to the next.

3.4 LAYING MASONRY WALLS

- A. Lay out walls in advance for accurate spacing of surface bond patterns with uniform joint thicknesses and for accurate location of openings, movement-type joints, returns, and offsets. Avoid using less-than-half-size units, particularly at corners, jambs, and, where possible, at other locations.
- B. Bond Pattern for Exposed Masonry: Unless otherwise indicated, lay exposed masonry in running bond pattern indicated on Drawings. Do not use units with less-than-nominal 4 inch horizontal face dimensions at corners or jambs.

**NISQUALLY STATE PARK
NEW FULL SERVICE PARK – PHASE 2**

- C. Stopping and Resuming Work: Stop Work by stepping back units in each course from those in course below; do not tooth. When resuming Work, clean masonry surfaces that are to receive mortar, remove loose masonry units and mortar, and wet brick if required before laying fresh masonry.
- D. Built-in Work: As construction progresses, build in items specified in this and other Sections. Fill in solidly with masonry around built-in items.

3.5 MORTAR BEDDING AND JOINTING

- A. Lay hollow brick with face shells fully bedded in mortar and with head joints of depth equal to bed joints. At starting course, fully bed entire units, including area under cells.
 - 1. At anchors and ties, fully bed units and fill cells with mortar as needed to fully embed anchors and ties in mortar.
- B. Tool exposed joints slightly concave when thumbprint hard, using a jointer larger than joint thickness unless otherwise indicated.

3.6 ANCHORED MASONRY VENEERS

- A. Anchor masonry veneers to wall framing with seismic masonry-veneer anchors to comply with the following requirements:
 - 1. Fasten screw-attached and seismic anchors through sheathing to wall framing with metal fasteners of type indicated.
 - a. Use 2 fasteners unless anchor design only uses 1 fastener.
 - 2. Embed connector sections and continuous wire in masonry joints.
 - 3. Locate anchor sections to allow maximum vertical differential movement of ties up and down.
 - 4. Space anchors as indicated, but not more than 18 inches on center vertically and 24 inches on center horizontally, with not less than one anchor for each 2 sq. ft. of wall area. Install additional anchors within 12 inches of openings and at intervals, not exceeding 8 inches, around perimeter.
 - 5. Add 24 inch long segments of joint reinforcing for anchors that do not align with typical anchor rows beyond.
- B. Provide not less than 2 inches of airspace between back of masonry veneer and face of sheathing or insulation.
 - 1. Keep airspace clean of mortar droppings and other materials during construction. Bevel beds away from airspace, to minimize mortar protrusions into airspace. Do not attempt to trowel or remove mortar fins protruding into airspace.

**NISQUALLY STATE PARK
NEW FULL SERVICE PARK – PHASE 2**

3.7 ANCHORING MASONRY TO STRUCTURAL STEEL

- A. Anchor masonry to structural steel, where masonry abuts or faces structural steel or concrete to comply with the following:
 - 1. Provide an open space not less than 1 inch wide between masonry and structural steel unless otherwise indicated. Keep open space free of mortar and other rigid materials.
 - 2. Anchor masonry with anchors embedded in masonry joints and attached to structure.
 - 3. Space anchors as indicated, but not more than 24 inches on center vertically and 36 inches on center horizontally.

3.8 EXPANSION JOINTS

- A. Install expansion-joint materials in unit masonry as masonry progresses. Do not allow materials to span expansion joints without provision to allow for in-plane wall or partition movement.
- B. Form expansion joints as follows:
 - 1. Build flanges of metal expansion strips into masonry. Lap each joint 4 inches in direction of water flow. Seal joints below grade and at junctures with horizontal expansion joints if any.
 - 2. Build flanges of factory-fabricated, expansion-joint units into masonry.
 - 3. Build in compressible joint fillers where indicated.
 - 4. Form open joint full depth of brick wythe and of width indicated, but not less than 3/8 inch for installation of sealant and backer rod specified in Section 079200 – Joint Sealants.
- C. Provide horizontal, pressure-relieving joints by either leaving an airspace or inserting a compressible filler of width required for installing sealant and backer rod specified in Section 079200 – Joint Seals, but not less than 3/8 inch.
 - 1. Locate horizontal, pressure-relieving joints beneath shelf angles supporting masonry.

3.9 LINTELS

- A. Install steel lintels where indicated.
- B. Provide minimum bearing of 8 inches at each jamb unless otherwise indicated.

3.10 FLASHING, WEEP HOLES, AND VENTS

- A. Install embedded flashing and weep holes in masonry at shelf angles, lintels, ledges, other obstructions to downward flow of water in wall, and where indicated. Install cavity vents at shelf angles, ledges, and other obstructions to upward flow of air in cavities, and where indicated.
- B. Install flashing as follows unless otherwise indicated:
 - 1. Prepare masonry surfaces so they are smooth and free from projections that could puncture flashing. Where flashing is within mortar joint, place through-wall flashing on sloping bed of

**NISQUALLY STATE PARK
NEW FULL SERVICE PARK – PHASE 2**

- mortar and cover with mortar. Before covering with mortar, seal penetrations in flashing with adhesive, sealant, or tape as recommended by flashing manufacturer.
2. Extend flashing through veneer, across airspace behind veneer, and up face of sheathing at least 8 inches; with upper edge tucked under water-resistive barrier air or barrier, lapping at least 4 inches. Fasten upper edge of flexible flashing to sheathing through termination bar.
 3. At lintels and shelf angles, extend flashing a minimum of 6 inches into masonry at each end. At heads and sills, extend flashing 6 inches at ends and turn up not less than 4 inches to form end dams.
 4. Install metal drip edges beneath flexible flashing at exterior face of wall. Stop flexible flashing 1/2 inch back from outside face of wall, and adhere flexible flashing to top of metal drip edge.
- C. Install weep holes in exterior veneers in head joints of first course of masonry immediately above embedded flashing.
1. Use specified weep tubes to form weep holes.
 2. Space weep holes at 16 inches on center unless otherwise indicated.
 3. Trim wicking material flush with outside face of wall after mortar has set.
- D. Place cavity drainage material in cavities and airspace behind veneers to comply with configuration requirements for cavity drainage material in "Miscellaneous Masonry Accessories" Article.
- E. Install specified cavity vents in head joints in exterior wythes at spacing indicated to form cavity vents.
1. Close cavities off vertically and horizontally with blocking in manner indicated.
 2. Install through-wall flashing and weep holes above horizontal blocking.

3.11 REPAIR

- A. Remove and replace masonry units that are loose, chipped, broken, stained, or otherwise damaged or that do not match adjoining units. Install new units to match adjoining units; install in fresh mortar, pointed to eliminate evidence of replacement.

3.12 FIELD QUALITY CONTROL

- A. Testing and Inspecting: Owner will engage special inspectors to perform tests and inspections and prepare reports. Allow inspectors access to scaffolding and Work areas as needed to perform tests and inspections. Retesting of materials that fail to comply with specified requirements shall be done at Contractor's expense.
- B. Inspections: Special inspections according to Level B in TMS 402.
1. Begin masonry construction only after inspectors have verified proportions of site-prepared mortar.
- C. Testing Prior to Construction: 1 set of tests.
- D. Clay Masonry Unit Test: For each type of unit provided, according to ASTM C67 for compressive strength.

**NISQUALLY STATE PARK
NEW FULL SERVICE PARK – PHASE 2**

- E. Mortar Aggregate Ratio Test (Proportion Specification): For each mix provided, according to ASTM C780.

3.13 POINTING

- A. Pointing: During tooling of joints, enlarge voids and holes, except weep holes, and completely fill with mortar. Point up joints, including corners, openings, and adjacent construction, to provide a neat, uniform appearance. Prepare joints for sealant application, where indicated.

3.14 CLEANING

- A. In-Progress Cleaning: Clean unit masonry as Work progresses by dry brushing to remove mortar fins and smears before tooling joints.
- B. Final Cleaning: After mortar is thoroughly set and cured, clean exposed masonry as follows:
 - 1. Remove large mortar particles by hand with wooden paddles and nonmetallic scrape hoes or chisels.
 - 2. Test cleaning methods on sample wall panel; leave 1/2 of panel uncleaned for comparison purposes. Obtain Architect's approval of sample cleaning before proceeding with cleaning of masonry.
 - 3. Protect adjacent nonmasonry surfaces from contact with cleaner by covering them with liquid strippable masking agent or polyethylene film and waterproof masking tape.
 - 4. Wet wall surfaces with water before applying cleaners; remove cleaners promptly by rinsing surfaces thoroughly with clear water.
 - 5. Clean brick by bucket-and-brush hand-cleaning method described in BIA Technical Notes 20.
 - 6. Clean masonry with a proprietary acidic cleaner applied according to manufacturer's written instructions.

3.15 MASONRY WASTE DISPOSAL

- A. Salvageable Materials: Unless otherwise indicated, excess masonry materials are Contractor's property. At completion of unit masonry Work, remove from Project site.
- B. Excess Masonry Waste: Remove excess clean masonry waste that cannot be used as fill, as described above or recycled, and other masonry waste, and legally dispose of off Owner's property.

END OF SECTION

**NISQUALLY STATE PARK
NEW FULL SERVICE PARK – PHASE 2**

SECTION 043000 – GATE PLINTHS

PART 1 - GENERAL

1.1 SUMMARY

- A. Section includes providing the Gate Plinths for the Slide Gate in the Administrative Building parking area.

1.2 RELATED WORK

- A. Coordinate related work and requirements specified in other parts of the Contract Documents, including but not limited to the following:
 - 1. Section 032000 – Concrete Reinforcing
 - 2. Section 033000 – Cast-in-Place Concrete

1.3 ACTION SUBMITTALS

- A. Product Data: For each type of product.
- B. Shop Drawings: For the following:
 - 1. Masonry Units: Show sizes, profiles, coursing, and locations of special shapes.
- C. Samples for Verification: For each type and color of the following:
 - 1. Clay face brick, in the form of straps of 5 or more bricks.
 - 2. Special brick shapes.
 - 3. Pigmented mortar. Make Samples using same sand and mortar ingredients to be used on Project.

1.4 INFORMATIONAL SUBMITTALS

- A. List of Materials Used in Constructing Mockups: List generic product names together with manufacturers, manufacturers' product names, model numbers, lot numbers, batch numbers, source of supply, and other information as required to identify materials used. Include mix proportions for mortar and grout and source of aggregates.
 - 1. Submittal is for information only. Receipt of list does not constitute approval of deviations from the Contract Documents unless such deviations are specifically brought to the attention of Landscape Architect and approved in writing.
- B. Material Certificates: For each type and size of the following:
 - 1. Masonry units.

**NISQUALLY STATE PARK
NEW FULL SERVICE PARK – PHASE 2**

- a. Include data on material properties or material test reports substantiating compliance with requirements.
 - b. For brick, include size-variation data verifying that actual range of sizes falls within specified tolerances.
 - c. For exposed brick, include test report for efflorescence according to ASTM C67.
2. Cementitious materials. Include name of manufacturer, brand name, and type.
 3. Mortar admixtures.
 4. Anchors, ties, and metal accessories.
- C. Mix Designs: For each type of mortar. Include description of type and proportions of ingredients.
1. Include test reports for mortar mixes required to comply with property specification. Test according to ASTM C109 for compressive strength, ASTM C1506 for water retention, and ASTM C91 for air content.
- D. Cold-Weather and Hot-Weather Procedures: Detailed description of methods, materials, and equipment to be used to comply with requirements.

1.5 QUALITY ASSURANCE

- A. Manufacturer: Company operating in the United States having U.S. manufacturing facility/facilities specializing in manufacturing products specified in this section with a minimum of five years documented experience.
- B. Installer Qualifications: Company specializing in performing work of this section with a minimum of five years documented experience with projects of similar scope and complexity.
- C. Source Limitations: Provide each type of product from a single manufacturing source to ensure uniformity.
- D. Tolerances: Current published edition of ASTM specifications tolerances apply. ASTM specification tolerances supersede any conflicting tolerance.
- E. Mockups: Mockups are built to verify selections made under Sample submittals, to demonstrate aesthetic effects, and to set quality standards for materials and execution.
 1. Unless indicated otherwise by Landscape Architect, build mockups for each type of exposed unit masonry construction in sizes approximately 48 inches long by 48 inches high by full thickness, including accessories. Include the following:
 - a. Sealant-filled mortar joint at least 16 inches long in exterior wall mockup.
 - b. Utilize brick of each color specified.
 - c. CMU bond beam, CMU Block, brick veneer anchor, and rebar, in wall mockup.
 2. Protect approved mockups from elements with weather-resistant membrane.
 3. Approval of mockups is for color, texture, and blending of masonry units; relationship of mortar and sealant colors to masonry unit colors; tooling of joints; and aesthetic qualities of workmanship.

**NISQUALLY STATE PARK
NEW FULL SERVICE PARK – PHASE 2**

- a. Approval of mockups is also for other material and construction qualities specifically approved by Landscape Architect in writing.
 - b. Approval of mockups does not constitute approval of deviations from Contract Documents contained in mockups unless such deviations are specifically approved by Landscape Architect in writing.
4. Subject to compliance with requirements, approved mockups may become part of completed Work if undisturbed and approved by Owner's Representative at time of Substantial Completion.

1.6 DELIVERY, STORAGE, AND HANDLING

- A. Store masonry units on elevated platforms in a dry location. If units are not stored in an enclosed location, cover tops and sides of stacks with waterproof sheeting, securely tied. If units become wet, do not install until they are dry.
- B. Store cementitious materials on elevated platforms, under cover, and in a dry location. Do not use cementitious materials that have become damp.
- C. Store aggregates where grading and other required characteristics can be maintained, and contamination avoided.
- D. Store masonry accessories, including metal items, to prevent corrosion and accumulation of dirt and oil.

1.7 FIELD CONDITIONS

- A. Protection of Masonry: During construction, cover tops of veneer, and projections with waterproof sheeting at end of each day's Work. Cover partially completed masonry when construction is not in progress.
 1. Extend cover a minimum of 24 inches down face of veneer, and hold cover securely in place.
- B. Stain Prevention: Prevent grout, mortar, and soil from staining the face of masonry. Immediately remove grout, mortar, and soil that come in contact with masonry.
 1. Protect base of walls from rain-splashed mud and from mortar splatter/droppings by spreading coverings on ground and over wall surface.
- C. Cold-Weather Requirements: Do not use frozen materials or materials mixed or coated with ice or frost. Do not build on frozen substrates. Remove and replace unit masonry damaged by frost or by freezing conditions. Comply with cold-weather construction requirements contained in TMS 602.
 1. Cold-Weather Cleaning: Use liquid cleaning methods only when air temperature is 40 deg F and higher and will remain so until masonry has dried, but not less than 7 days after completing cleaning.

**NISQUALLY STATE PARK
NEW FULL SERVICE PARK – PHASE 2**

- D. Hot-Weather Requirements: Comply with hot-weather construction requirements contained in TMS 602.

1.8 WARRANTY

- A. Manufacturer's standard limited warranty unless indicated otherwise.

PART 2 - PRODUCTS

2.1 MANUFACTURERS

- A. Source Limitations for Masonry Units: Obtain exposed masonry units of a uniform texture and color, or a uniform blend within ranges accepted for these characteristics, from single source from single manufacturer for each product required.
- B. Source Limitations for Mortar Materials: Obtain mortar ingredients of a uniform quality, including color for exposed masonry, from single manufacturer for each cementitious component and from single source or producer for each aggregate.
- C. Acceptable Manufacturer: Mutual Materials, Address: 2201 115th Street South Parkland, WA 98444, Phone: 253-238-5490, Website: www.mutualmaterials.com, or approved equal.

2.2 UNIT MASONRY, GENERAL

- A. Masonry Standard: Comply with TMS 602, except as modified by requirements in Contract Documents.
- B. Defective Units: Referenced masonry unit standards may allow a certain percentage of units to contain chips, cracks, or other defects exceeding limits stated. Do not use units where such defects are exposed in completed Work and will be within 20 feet vertically and horizontally of a walking surface.

2.3 BRICK

- A. Regional Materials: Verify brick is manufactured within 500 miles of Project site from materials that have been extracted, harvested, or recovered, as well as manufactured, within 500 miles of Project site.
- B. Provide shapes indicated and as follows, with exposed surfaces matching finish and color of exposed faces of adjacent units:
 - 1. Provide special shapes for applications where shapes produced by sawing would result in sawed surfaces being exposed to view.
 - 2. Unit Compressive Strength: Provide units with minimum average net-area compressive strength of 3,350 psi.
- C. Clay Face Brick: Facing brick complying with ASTM C216.

**NISQUALLY STATE PARK
NEW FULL SERVICE PARK – PHASE 2**

1. Basis-of-Design Manufacturer: Subject to compliance with requirements, provide products by Name of Company or approved substitutions:
 - a. H. C. Muddox.
 - b. Interstate Bricks.
 - c. Mutual Materials Co.
 - d. Pacific Clay Products, Inc.
 - e. Approved substitutions.
2. Grade: Severe Weathering (SW)
3. Type: FBX.
4. Initial Rate of Absorption: ASTM C67; less than 30 g/30 sq. in. per minute.
5. Efflorescence: ASTM C67; rated "not effloresced."
6. Size (Actual Dimensions): 3-1/2 inches wide, 2-1/2 inches high, 7-1/2 inches long.
7. Colors: Vintage (Red); Redondo Gray; Ebony
8. Application: Use where brick is exposed unless otherwise indicated.

2.4 MORTAR MATERIALS

- A. Portland Cement: ASTM C150, Type I or II, except Type III may be used for cold-weather construction. Provide natural color or white cement as required to produce mortar color indicated.
 1. Alkali content shall not be more than 0.1 percent when tested according to ASTM C114.
- B. Hydrated Lime: ASTM C207, Type S.
- C. Portland Cement-Lime Mix: Packaged blend of Portland Cement and hydrated lime containing no other ingredients.
- D. Masonry Cement: Not allowed.
- E. Mortar Cement: ASTM C1329.
 1. Products: Subject to compliance with requirements, provide one of the following:
 - a. Blue Circle Cement: Magnolia Superbond Mortar Cement.
 - b. Lafarge North America Inc.: Lafarge Mortar Cement.
 - c. SPEC MIX, Inc.: Mortar Cement & Sand.
 - d. Approved substitution.
- F. Colored Cement Products: Packaged blend made from Portland Cement, hydrated lime, and mortar pigments, complying with specified requirements, and containing no other ingredients.
 1. Colored Portland Cement-Lime Mix:
 2. Manufacturers: Subject to compliance with requirements, provide products from one of the following:
 - a. LafargeHolcim North America Inc.
 - b. Lehigh Hanson; HeidelbergCement Group.

**NISQUALLY STATE PARK
NEW FULL SERVICE PARK – PHASE 2**

- c. SPEC MIX, Inc.
 - d. Approved substitution.
 - 3. Formulate blend as required to produce color indicated or, if not indicated, as selected from manufacturer's standard colors by Owner's Representative.
 - 4. Pigments shall not exceed 10 percent of Portland Cement by weight.
 - 5. Pigments shall not exceed 5 percent of mortar cement by weight.
- G. Aggregate for Mortar: ASTM C144.
- 1. For mortar that is exposed to view, use washed aggregate consisting of natural sand or crushed stone.
 - 2. For joints less than 1/4 inch thick, use aggregate graded with 100 percent passing No. 16 sieve.
 - 3. White-Mortar Aggregates: Natural white sand or crushed white stone.
 - 4. Colored-Mortar Aggregates: Natural sand or crushed stone of color necessary to produce required mortar color.
- H. Cold-Weather Admixture: Nonchloride, noncorrosive, accelerating admixture complying with ASTM C494/, Type C, and recommended by manufacturer for use in masonry mortar of composition indicated.
- 1. Products: Subject to compliance with requirements, provide one of the following:
 - a. Addiment Incorporated: Mortar Kick.
 - b. Euclid Chemical Company (The): Accelguard 80.
 - c. GCP Applied Technologies Inc.: Morset.
- I. Water: Potable.

2.5 DECORATIVE METAL BASKET

- A. (2) Two decorative steel metal baskets will be provided by Owner for Contractor to install, as indicated in the Drawings.

2.6 FASTENERS

- A. All bolts shall be galvanized with a black finish of the size noted on Drawings. All bolts shall have nuts and washers of similar grade/size as noted.

2.7 MASONRY CLEANERS

- A. Proprietary Acidic Cleaner: Manufacturer's standard-strength cleaner designed for removing mortar/grout stains, efflorescence, and other new construction stains from new masonry without discoloring or damaging masonry surfaces. Use product expressly approved for intended use by cleaner manufacturer and manufacturer of masonry units being cleaned.
 - 1. Products: Subject to compliance with requirements, provide one of the following:

**NISQUALLY STATE PARK
NEW FULL SERVICE PARK – PHASE 2**

- a. Diedrich Technologies, Inc.; a division of Hohmann & Barnard, Inc.: 202 New Masonry Detergent.
- b. EaCo Chem, Inc.: NMD 80.
- c. ProSoCo, Inc.: Sure Klean 600.
- d. Approved substitution.

2.8 MORTAR MIXES

- A. Do not use admixtures, including pigments, air-entraining agents, accelerators, retarders, water-repellent agents, antifreeze compounds, or other admixtures unless otherwise indicated.
 1. Do not use calcium chloride in mortar or grout.
 2. Use Portland Cement-lime mortar unless otherwise indicated.
 3. For exterior masonry, use Portland Cement-lime mortar.
 4. For reinforced masonry, use Portland Cement-lime mortar.
 5. Add cold-weather admixture (if used) at same rate for mortar that will be exposed to view, regardless of weather conditions, to ensure that mortar color is consistent.
- B. Mortar for Unit Masonry: Comply with ASTM C270, Proportion Specification. Use Type N unless another type is indicated.
 1. Type M: 2,500 psi; for masonry below grade or in contact with earth.
 2. Type S: 1,800 psi; for exterior, above-grade brick veneer.
- C. Pigmented Mortar: Use colored cement product or select and proportion pigments with other ingredients to produce color required. Do not add pigments to colored cement products.
 1. Pigments shall not exceed 10 percent of Portland Cement by weight.
 2. Pigments shall not exceed 5 percent of mortar cement by weight.
 3. Mix to match Architect's sample.
 4. Application: Use pigmented mortar for exposed mortar joints.

PART 3 - EXECUTION

3.1 EXAMINATION

- A. Examine conditions, with Installer present, for compliance with requirements for installation tolerances and other conditions affecting performance of Work.
 1. For the record, prepare a written report, endorsed by Installer, listing conditions detrimental to performance of Work.
- B. Proceed with installation only after unsatisfactory conditions have been corrected.

**NISQUALLY STATE PARK
NEW FULL SERVICE PARK – PHASE 2**

3.2 INSTALLATION, GENERAL

- A. Thickness: Build cavity and composite walls and other masonry construction to full thickness shown. Build single-wythe walls to actual widths of masonry units, using units of widths indicated.
- B. Use full-size units without cutting if possible. If cutting is required to provide a continuous pattern or to fit adjoining construction, cut units with motor-driven saws; provide clean, sharp, unchipped edges. Allow units to dry before laying unless wetting of units is specified. Install cut units with cut surfaces and, where possible, cut edges concealed.
- C. Select and arrange units for exposed unit masonry to produce a uniform blend of colors, pattern, and textures as indicated in Drawings. Mix units from several pallets or cubes as they are placed.
- D. Wetting of Brick: Wet brick before laying if initial rate of absorption exceeds 30 g/30 sq. in. per minute when tested according to ASTM C67. Allow units to absorb water so they are damp but not wet at time of laying.

3.3 TOLERANCES

A. Dimensions and Locations of Elements:

- 1. For dimensions in cross section or elevation, do not vary by more than plus 1/2 inch or minus 1/4 inch.
- 2. For location of elements in plan, do not vary from that indicated by more than plus or minus 1/2 inch.
- 3. For location of elements in elevation, do not vary from that indicated by more than plus or minus 1/4 inch in a story height or 1/2-inch total.

B. Lines and Levels:

- 1. For bed joints and top surfaces of walls, do not vary from level by more than 1/4 inch in 10 feet, or 1/2 inch maximum.
- 2. For conspicuous horizontal lines, such as lintels, sills, parapets, and reveals, do not vary from level by more than 1/8 inch in 10 feet, 1/4 inch in 20 feet, or 1/2 inch maximum.
- 3. For vertical lines and surfaces, do not vary from plumb by more than 1/4 inch in 10 feet, 3/8 inch in 20 feet, or 1/2 inch maximum.
- 4. For conspicuous vertical lines, such as external corners, do not vary from plumb by more than 1/8 inch in 10 feet, 1/4 inch in 20 feet, or 1/2 inch maximum.
- 5. For lines and surfaces, do not vary from straight by more than 1/4 inch in 10 feet, 3/8 inch in 20 feet, or 1/2 inch maximum.
- 6. For vertical alignment of exposed head joints, do not vary from plumb by more than 1/4 inch in 10 feet or 1/2 inch maximum.
- 7. For faces of adjacent exposed masonry units, do not vary from flush alignment by more than 1/16 inch except due to warpage of masonry units within tolerances specified for warpage of units.

**NISQUALLY STATE PARK
NEW FULL SERVICE PARK – PHASE 2**

C. Joints:

1. For bed joints, do not vary from thickness indicated by more than plus or minus 1/8 inch, with a maximum thickness limited to 1/2 inch.
2. For exposed bed joints, do not vary from bed-joint thickness of adjacent courses by more than 1/8 inch.
3. For head and collar joints, do not vary from thickness indicated by more than plus 3/8 inch or minus 1/4 inch.
4. For exposed head joints, do not vary from thickness indicated by more than plus or minus 1/8 inch. Do not vary from adjacent bed-joint and head-joint thicknesses by more than 1/8 inch.
5. For exposed bed joints and head joints of stacked bond, do not vary from a straight line by more than 1/16 inch from one masonry unit to the next.

3.4 LAYING MASONRY WALLS

- A. Lay out walls in advance for accurate spacing of surface bond patterns with uniform joint thicknesses and for accurate location of openings, movement-type joints, returns, and offsets as indicated in Drawings. Avoid using less-than-half-size units, particularly at corners, and where possible, at other locations.
- B. Bond Pattern for Exposed Masonry: Unless otherwise indicated, lay exposed masonry in running bond. Lay basket weave in pattern indicated on Drawings. Submit proposed layout prior installation for Landscape Architect's approval. Do not use units with less-than-nominal 4-inch horizontal face dimensions at corners.
- C. Stopping and Resuming Work: Stop Work by stepping back units in each course from those in course below; do not tooth. When resuming Work, clean masonry surfaces that are to receive mortar, remove loose masonry units and mortar, and wet brick if required before laying fresh masonry.
- D. Built-in Work: As construction progresses, build in items specified in this and other Sections. Fill in solidly with masonry around built-in items.

3.5 MORTAR BEDDING AND JOINTING

- A. Lay hollow brick with face shells fully bedded in mortar and with head joints of depth equal to bed joints. At starting course, fully bed entire units, including area under cells.
 1. At anchors and ties, fully bed units and fill cells with mortar as needed to fully embed anchors and ties in mortar.
- B. Tool exposed joints slightly concave when thumbprint hard, using a jointer larger than joint thickness unless otherwise indicated.

**NISQUALLY STATE PARK
NEW FULL SERVICE PARK – PHASE 2**

3.6 REPAIR

- A. Remove and replace masonry units that are loose, chipped, broken, stained, or otherwise damaged or that do not match adjoining units. Install new units to match adjoining units; install in fresh mortar, pointed to eliminate evidence of replacement.

3.7 FIELD QUALITY CONTROL

- A. Testing and Inspecting: Owner will engage special inspectors to perform tests and inspections and prepare reports. Allow inspectors access to scaffolding and Work areas as needed to perform tests and inspections. Retesting of materials that fail to comply with specified requirements shall be done at Contractor's expense.
- B. Inspections: Special inspections according to Level B in TMS 402.
 - 1. Begin masonry construction only after inspectors have verified proportions of site-prepared mortar.
- C. Testing Prior to Construction: 1 set of tests.
- D. Clay Masonry Unit Test: For each type of unit provided, according to ASTM C67 for compressive strength.
- E. Mortar Aggregate Ratio Test (Proportion Specification): For each mix provided, according to ASTM C780.

3.8 POINTING

- A. Pointing: During tooling of joints, enlarge voids and holes, except weep holes, and completely fill with mortar. Point up joints, including corners, openings, and adjacent construction, to provide a neat, uniform appearance. Prepare joints for sealant application, where indicated.
- B. Joints will have Keyed Pointing where a concave channel of 3 mm depth is created at the middle of the mortar joint, as indicated in Drawings.

3.9 HOLES FOR BOLTS AND SCREWS

- A. Holes for connecting hardware and fasteners shall be drilled with a bit 1/16-inch smaller in diameter than the screws and bolts.

3.10 FASTENING

- A. Fasten decorative metal baskets plumb and level on Gate Plinths as indicated on Drawing.

**NISQUALLY STATE PARK
NEW FULL SERVICE PARK – PHASE 2**

3.11 CLEANING

- A. In-Progress Cleaning: Clean unit masonry as Work progresses by dry brushing to remove mortar fins and smears before tooling joints.
- B. Final Cleaning: After mortar is thoroughly set and cured, clean exposed masonry as follows:
 - 1. Remove large mortar particles by hand with wooden paddles and nonmetallic scrape hoes or chisels.
 - 2. Test cleaning methods on sample wall panel; leave 1/2 of panel uncleaned for comparison purposes. Obtain Landscape Architect's approval of sample cleaning before proceeding with cleaning of masonry.
 - 3. Protect adjacent nonmasonry surfaces from contact with cleaner by covering them with liquid strippable masking agent or polyethylene film and waterproof masking tape.
 - 4. Wet wall surfaces with water before applying cleaners; remove cleaners promptly by rinsing surfaces thoroughly with clear water.
 - 5. Clean brick by bucket-and-brush hand-cleaning method described in BIA Technical Notes 20.
 - 6. Clean masonry with a proprietary acidic cleaner applied according to manufacturer's written instructions.

3.12 MASONRY WASTE DISPOSAL

- A. Salvageable Materials: Unless otherwise indicated, excess masonry materials are Contractor's property. At completion of unit masonry Work, remove from Project site.
- B. Waste Disposal as Fill Material: Dispose of clean masonry waste, including excess or soil-contaminated sand, waste mortar, and broken masonry units, by crushing and mixing with fill material as fill is placed.
 - 1. Crush masonry waste to less than 4 inches in each dimension.
 - 2. Mix masonry waste with at least 2 parts of specified fill material for each part of masonry waste. Fill material is specified in Division 31 Section for Earth Moving.
 - 3. Do not dispose of masonry waste as fill within 18 inches of finished grade.
- C. Excess Masonry Waste: Remove excess clean masonry waste that cannot be used as fill, as described above or recycled, and other masonry waste, and legally dispose of off Owner's property.

END OF SECTION

**NISQUALLY STATE PARK
NEW FULL SERVICE PARK – PHASE 2**

SECTION 051200 – STRUCTURAL STEEL FRAMING

PART 1 - GENERAL

1.1 SUMMARY

- A. Section Includes:
1. Structural-steel materials.
 2. Shrinkage-resistant grout.

1.2 DEFINITIONS

- A. Structural Steel: Elements of the structural frame indicated on Drawings and as described in ANSI/AISC 303.
- B. Heavy Sections: Rolled and built-up sections as follows:
1. Shapes included in ASTM A6 with flanges thicker than 1-1/2 inches.
 2. Welded built-up members with plates thicker than 2 inches.
 3. Column base plates thicker than 2 inches.
- C. Welding Procedure Qualification Record (WPQR). A record comprising necessary data needed for qualification of a preliminary welding procedure specification.
- D. Welding Procedure Specification (WPS): Formal written document describing welding procedures.

1.3 ADMINISTRATIVE REQUIREMENTS

- A. Coordination: Coordinate the following:
1. Selection of shop primers with topcoats to be applied over them.
 - a. Comply with paint and coating manufacturers' recommendations to ensure that shop primers and topcoats are compatible with one another.
 2. Installation of anchorage items to be embedded in or attached to other construction without delaying Work.
 - a. Provide embedment drawings, setting diagrams, sheet metal templates, instructions, and directions for installation.
- B. Preinstallation Meeting: Conduct meeting at Project site.
1. Meeting Time: Schedule meeting a minimum of 2 weeks prior to beginning Work of this Section and related Work.

**NISQUALLY STATE PARK
NEW FULL SERVICE PARK – PHASE 2**

2. Attendees: Owner, Architect, structural engineer, Contractor, Contractor's Superintendent, independent testing agency responsible for steel inspections, steel erection Subcontractor, manufacturer representatives of structural steel, steel joist, and steel decks, steel fabricator, and other entities as requested to attend.
3. Agenda Items:
 - a. Review the following items:
 - 1) Project chain of communications.
 - 2) Project schedule.
 - 3) Fabrication and erection procedures and schedules.
 - 4) Procedures for bolting and welding.
 - 5) Temporary frame stability/shoring procedures.
 - 6) WPSs and WPQRs for completeness and applicability.
 - b. Discuss safety issues, procedures for addressing non-conformance in shop and field, RFI procedures, and unique steel members or conditions that warrant special attention or erection sequencing.
 - c. Special Inspections and Testing Agency Procedures:
 - 1) Coordinate shop and field quality control with fabricator and erector.
 - 2) Verify fabricator and erector's QA procedures including joist installation and metal roof deck attachment procedures.
 - 3) Coordination of inspections.

1.4 ACTION SUBMITTALS

A. Product Data:

1. Structural-steel materials.
2. High-strength, bolt-nut-washer assemblies.
3. Shear stud connectors.
4. Anchor rods.
5. Threaded rods.
6. Forged-steel hardware.
7. Shop primer.
8. Galvanized-steel primer.
9. Etching cleaner.
10. Galvanized repair coating.

B. Shop Drawings: For fabrication of structural-steel components indicated on Drawings to comply with performance and design criteria. Include the following information:

1. Details of cuts, connections, splices, camber, holes, and other pertinent data.
2. Embedment Drawings.
3. Indicate welds by standard AWS symbols, distinguishing between shop and field welds, and show size, length, and type of weld. Show backing bars that are to be removed and supplemental fillet welds where backing bars are to remain.
4. Indicate type, size, and length of bolts, distinguishing between shop and field bolts.

**NISQUALLY STATE PARK
NEW FULL SERVICE PARK – PHASE 2**

5. Identify members not to be shop primed.
 6. Analysis data and calculations showing compliance with structural and seismic performance requirements.
 7. Include analysis data and calculations signed and sealed by qualified professional engineer responsible for their preparation.
- C. Erection Drawings: Indicate information necessary for erection of steel structure in compliance with AISC requirements.
- D. Welding Procedure Specifications (WPSs) and Welding Procedure Qualification Records (WPQRs): Provide according to AWS D1.1 for each welded joint whether prequalified or qualified by testing, including the following:
1. Power source (constant current or constant voltage).
 2. Electrode manufacturer and trade name, for demand critical welds.
- 1.5 INFORMATIONAL SUBMITTALS
- A. Qualification Data:
1. For Installer.
 2. For fabricator.
- B. Welding certificates.
- C. Quality Control (QC) Manuals: Fabricators' and erectors' written manuals for quality control procedures. Include minimally acceptable material control procedures, inspection procedures, and procedures for correction of non-conformance necessary to ensure quality of erected structural steel according to AISC.
- D. Paint Compatibility Certificates: From manufacturers of topcoats applied over shop primers, certifying that shop primers are compatible with topcoats.
- E. Steel Primer Certification: From steel fabricator for specific surface preparation procedures and primers used for fabricated steel items to verify compliance with Specifications and compatibility of finish coat materials.
- F. Mill test reports for structural steel, including chemical and physical properties.
- G. Test and Evaluation Reports: For the following:
1. Bolts, nuts, and washers, including mechanical properties and chemical analysis.
 2. Direct-tension indicators.
 3. Tension-control, high-strength, bolt-nut-washer assemblies.
 4. Shear stud connectors.
 5. Shop primers.
 6. Nonshrink grout.

**NISQUALLY STATE PARK
NEW FULL SERVICE PARK – PHASE 2**

1.6 QUALITY ASSURANCE

- A. Fabricator Qualifications: A qualified fabricator, with a minimum of 5 years documented experience with commercial quality work comparable in scope to this Project,.
- B. Installer Qualifications: A qualified installer, with a minimum of 5 years documented experience with commercial quality work comparable in scope to this Project,.
- C. Shop-Painting Applicators: An installer, with a minimum of 5 years documented experience with commercial quality work comparable in scope to this Project, who is qualified according to AISC's Sophisticated Paint Endorsement P1, Endorsement P2, Endorsement P3, or to SSPC-QP 3.
- D. Welding Qualifications: Qualify procedures and personnel in accordance with AWS D1.1.
 - 1. Use welders certified by AWS and the State in which Project is located for structural welding, and who have undergone recertification within the past 12 months.
 - 2. Welders and welding operators performing Work on bottom-flange, demand-critical welds shall pass supplemental welder qualification testing, as required by AWS D1.8. FCAW-S and FCAW-G.
 - a. This shall be considered separate processes for welding personnel qualification.

1.7 DELIVERY, STORAGE, AND HANDLING

- A. Store materials to permit easy access for inspection and identification.
 - 1. Keep steel members off ground and spaced by using pallets, dunnage, or other supports and spacers.
 - 2. Protect steel members and packaged materials from corrosion and deterioration.
 - 3. Do not store materials on structure in a manner that might cause distortion, damage, or overload to members or supporting structures.
 - 4. Repair or replace damaged materials or structures as directed.
- B. Store fasteners in a protected place in sealed containers with manufacturer's labels intact.
 - 1. Fasteners may be repackaged provided Owner's testing and inspecting agency observes repackaging and seals containers.
 - 2. Clean and relubricate bolts and nuts that become dry or rusty before use.
 - 3. Comply with manufacturers' written recommendations for cleaning and lubricating ASTM F3125, Grade F1852 bolt assemblies and for retesting bolt assemblies after lubrication.

PART 2 - PRODUCTS

2.1 PERFORMANCE CRITERIA

- A. Comply with applicable provisions of the following specifications and documents:
 - 1. ANSI/AISC 303.

**NISQUALLY STATE PARK
NEW FULL SERVICE PARK – PHASE 2**

2. ANSI/AISC 341.
3. ANSI/AISC 360.
4. RCSC's "Specification for Structural Joints Using High-Strength Bolts."

B. Connection Design Information:

1. Connection designs have been completed and connections indicated on Drawings.

2.2 STRUCTURAL-STEEL MATERIALS

- A. W-Shapes and Channels 8 Inches and Larger: ASTM A992.
- B. Channels Smaller Than 8 Inches, Plates, and Bars: ASTM A36.
- C. Cold-Formed Hollow Structural Sections: ASTM A500, Grade C, structural tubing.
- D. Steel Pipe: ASTM A53, Type E or Type S, Grade B.
 1. Weight Class: As required according to approved Shop Drawings.
 2. Finish: Black, except where indicated to be galvanized.
- E. Welding Electrodes: Comply with AWS requirements and structural Drawing General Notes.

2.3 BOLTS, CONNECTORS, AND ANCHORS

- A. Framing Bolts, Nuts, and Washers: ASTM A307, Grade A, steel structural bolts; ASTM A563, heavy-hex carbon-steel nuts; and ASTM F436, Type 1, hardened carbon-steel washers; all with plain finish.

2.4 RODS

- A. Unheaded Anchor Rods: ASTM F1554, Grade 36.
 1. Configuration: As indicated on structural Drawings.
 2. Nuts: ASTM A563 heavy-hex carbon steel.
 3. Plate Washers: ASTM A36 carbon steel.
 4. Washers: ASTM F436, Type 1, hardened carbon steel.
 5. Finish: Plain.
- B. Headed Anchor Rods: ASTM F1554, Grade 36, straight.
 1. Nuts: ASTM A563 heavy-hex carbon steel.
 2. Plate Washers: ASTM A36 carbon steel.
 3. Washers: ASTM F436, Type 1, hardened carbon steel.
 4. Finish: Plain.

**NISQUALLY STATE PARK
NEW FULL SERVICE PARK – PHASE 2**

C. Threaded Rods: ASTM A36.

1. Nuts: ASTM A563 heavy-hex carbon steel.
2. Washers: ASTM A36 carbon steel.
3. Finish: Plain.

2.5 PRIMER

A. Steel Primer:

1. Comply with Section 099600 – High-Performance Coatings.
2. Fabricator's standard fast-curing, lead- and chromate-free, nonasphaltic, rust-inhibiting, primer complying with MPI #79 and compatible with topcoat.
3. Use primer containing pigments that make it easily distinguishable from zinc-rich primer.

B. Galvanized Steel Primer:

1. Vinyl wash primer complying with MPI #80.
2. Water-based galvanized metal primer complying with MPI #134.
3. Etching Cleaner: MPI #25 for galvanized metal as specified in Section 099000.

2.6 SHRINKAGE-RESISTANT GROUT

- A. Nonmetallic, Shrinkage-Resistant Grout: ASTM C1107, factory-packaged, nonmetallic aggregate grout, noncorrosive and nonstaining, mixed with water to consistency suitable for application and a 30 minute working time.

2.7 FABRICATION

- A. Structural Steel: Fabricate and assemble in shop to greatest extent possible. Fabricate according to ANSI/AISC 303, "Code of Standard Practice for Steel Buildings and Bridges," and to ANSI/AISC 360.

1. Camber structural-steel members where indicated.
2. Fabricate beams with rolling camber up.
3. Identify high-strength structural steel according to ASTM A6 and maintain markings until structural steel has been erected.
4. Mark and match-mark materials for field assembly.
5. Complete structural-steel assemblies, including welding of units, before starting shop-priming operations.

- B. Thermal Cutting: Perform thermal cutting by machine to greatest extent possible.

1. Plane thermally cut edges to be welded to comply with requirements in AWS D1.1.

- C. Bolt Holes: Cut, drill, mechanically thermal cut, or punch standard short-slotted and long-slotted bolt holes perpendicular to metal surfaces as indicated on Drawings.

**NISQUALLY STATE PARK
NEW FULL SERVICE PARK – PHASE 2**

- D. Finishing: Accurately finish ends of columns and other members transmitting bearing loads.
- E. Cleaning: Clean and prepare steel surfaces that are to remain unpainted according to SSPC-SP 3.
- F. Holes: Provide holes required for securing other Work to structural steel and for other Work to pass through steel members.
 - 1. Cut, drill, or punch holes perpendicular to steel surfaces. Do not thermally cut bolt holes or enlarge holes by burning.
 - 2. Baseplate Holes: Cut, drill, or punch holes perpendicular to steel surfaces.
 - 3. Weld threaded nuts to framing and other specialty items indicated to receive other Work.

2.8 SHOP CONNECTIONS

- A. High-Strength Bolts: Shop install high-strength bolts according to RCSC's "Specification for Structural Joints Using High-Strength Bolts" for type of bolt and type of joint specified.
 - 1. Joint Type: Snug tightened unless indicated otherwise.
- B. Weld Connections: Comply with AWS D1.1 and AWS D1.8 for tolerances, appearances, welding procedure specifications, weld quality, and methods used in correcting welding Work.
 - 1. Assemble and weld built-up sections by methods that maintain true alignment of axes without exceeding tolerances in ANSI/AISC 303 for mill material.

2.9 GALVANIZING

- A. Hot-Dip Galvanized Finish: Apply zinc coating by hot-dip process to structural steel according to ASTM A123. Do not quench or apply post-galvanizing treatments that might interfere with paint adhesion. Fill vent and drain holes that are exposed in finished Work unless they function as weep holes, by plugging with zinc solder and filing off smooth. Galvanize lintels and shelf angles attached to structural-steel frame and located in exterior walls.
- B. Galvanizing Repair Coating: Zinc-rich, cold galvanizing compound as specified in Section 055000 – Metal Fabrications.

2.10 SHOP PRIMING

- A. Shop prime steel surfaces except the following:
 - 1. Surfaces embedded in concrete or mortar. Extend priming of partially embedded members to a depth of 2 inches.
 - 2. Surfaces to be field welded.
 - 3. Surfaces to receive sprayed fire-resistive materials.
 - 4. Galvanized surfaces unless indicated to be painted.
 - 5. Surfaces enclosed in interior construction.

**NISQUALLY STATE PARK
NEW FULL SERVICE PARK – PHASE 2**

- B. Surface Preparation: Clean nongalvanized surfaces to be painted. Remove loose rust and mill scale and spatter, slag, or flux deposits. Prepare surfaces according to the following specifications and standards:
 - 1. SSPC-SP 3: Interior steel, performed after solvent cleaning according to SSPC-SP 1.
 - 2. SSPC-SP 6 (WAB)/NACE WAB-3: Exterior steel indicated to receive high-performance coatings.
- C. Surface Preparation of Galvanized Steel: Prepare galvanized-steel surfaces for shop priming by thoroughly cleaning steel of grease, dirt, oil, flux, and other foreign matter, and treating with etching cleaner or in accordance with SSPC-SP 16.
- D. Priming: Immediately after surface preparation, apply primer according to manufacturer's written instructions and at rate recommended by SSPC to provide a minimum dry film thickness of 1.5 mils. Use priming methods that result in full coverage of joints, corners, crevices, bolts, welds, sharp edges, and exposed surfaces.
 - 1. Apply 2 coats of shop paint to surfaces that are inaccessible after assembly or erection. Change color of second coat to distinguish it from first.

2.11 SOURCE QUALITY CONTROL

- A. Testing Agency: Owner may engage a qualified testing agency to perform shop tests and inspections.
 - 1. Provide testing agency with access to places where structural-steel Work is being fabricated or produced to perform tests and inspections.
- B. Welded Connections: Visually inspect shop-welded connections according to AWS D1.1 and the following inspection procedures, at testing agency's option:
 - 1. Liquid Penetrant Inspection: ASTM E165.
 - 2. Magnetic Particle Inspection: ASTM E709; performed on root pass and on finished weld. Cracks or zones of incomplete fusion or penetration are not accepted.
 - 3. Ultrasonic Inspection: ASTM E164.
- C. Prepare test and inspection reports.

PART 3 - EXECUTION

3.1 EXAMINATION

- A. Verify, with certified steel erector present, elevations of concrete- and masonry-bearing surfaces and locations of anchor rods, bearing plates, and other embedments for compliance with requirements.
 - 1. Prepare a certified survey of existing conditions. Include bearing surfaces, anchor rods, bearing plates, and other embedments showing dimensions, locations, angles, and elevations.
- B. Proceed with installation only after unsatisfactory conditions have been corrected.

**NISQUALLY STATE PARK
NEW FULL SERVICE PARK – PHASE 2**

3.2 PREPARATION

- A. Provide temporary shores, guys, braces, and other supports during erection to keep structural steel secure, plumb, and in alignment against temporary construction loads and loads equal in intensity to design loads. Remove temporary supports when permanent structural steel, connections, and bracing are in place unless otherwise indicated.

3.3 ERECTION

- A. Set structural steel accurately in locations and to elevations indicated and according to ANSI/AISC 303 and ANSI/AISC 360.
- B. Baseplates, Bearing Plates, and Leveling Plates: Clean concrete- and masonry-bearing surfaces of bond-reducing materials, and roughen surfaces prior to setting plates. Clean bottom surface of plates.
 - 1. Set plates for structural members on wedges, shims, or setting nuts as required.
 - 2. Weld plate washers to top of baseplate.
 - 3. Snug-tighten anchor rods after supported members have been positioned and plumbed. Do not remove wedges or shims but, if protruding, cut off flush with edge of plate before packing with grout.
 - 4. Promptly pack grout solidly between bearing surfaces and plates so no voids remain. Neatly finish exposed surfaces; protect grout and allow to cure. Comply with manufacturer's written installation instructions for shrinkage-resistant grouts.
- C. Maintain erection tolerances of structural steel within ANSI/AISC 303.
- D. Align and adjust various members that form part of complete frame or structure before permanently fastening. Before assembly, clean bearing surfaces and other surfaces that are in permanent contact with members. Perform necessary adjustments to compensate for discrepancies in elevations and alignment.
 - 1. Level and plumb individual members of structure.
 - 2. Make allowances for difference between temperature at time of erection and mean temperature when structure is completed and in service.
- E. Splice members only where indicated.
- F. Do not use thermal cutting during erection unless approved by Architect. Finish thermally cut sections within smoothness limits in AWS D1.1.
- G. Do not enlarge unfair holes in members by burning or using drift pins. Ream holes that must be enlarged to admit bolts.
- H. Shear Stud Connectors: Prepare steel surfaces as recommended by manufacturer of shear connectors. Use automatic end welding of headed-stud shear connectors according to AWS D1.1 and manufacturer's written instructions.

**NISQUALLY STATE PARK
NEW FULL SERVICE PARK – PHASE 2**

3.4 FIELD CONNECTIONS

- A. High-Strength Bolts: Install high-strength bolts according to RCSC's "Specification for Structural Joints Using High-Strength Bolts" for type of bolt and type of joint specified.
 - 1. Joint Type: Snug tightened, unless indicated otherwise.
- B. Weld Connections: Comply with AWS D1.1 and AWS D1.8 for tolerances, appearances, welding procedure specifications, weld quality, and methods used in correcting welding Work.
 - 1. Comply with ANSI/AISC 303 and ANSI/AISC 360 for bearing, alignment, adequacy of temporary connections, and removal of paint on surfaces adjacent to field welds.
 - 2. Remove backing bars or runoff tabs where indicated, back gouge, and grind steel smooth.
 - 3. Assemble and weld built-up sections by methods that maintain true alignment of axes without exceeding tolerances in ANSI/AISC 303, "Code of Standard Practice for Steel Buildings and Bridges," for mill material.

3.5 REPAIR

- A. Galvanized Surfaces: Clean field welds, bolted connections, and abraded areas, and repair with galvanizing repair coating.
- B. Touchup Painting: Immediately after erection, clean exposed areas where primer is damaged or missing and paint with same material as used for shop painting to comply with SSPC-PA 1 for touching up shop-painted surfaces.
 - 1. Clean and prepare surfaces by SSPC-SP 2 hand-tool cleaning or SSPC-SP 3 power-tool cleaning.
- C. Touchup Priming: Cleaning and touchup priming are specified in Section 099600 – High Performance Coatings.

3.6 FIELD QUALITY CONTROL

- A. Special Inspections: Owner will engage a qualified special inspector to perform the following special inspections:
 - 1. Verify structural-steel materials and inspect steel frame joint details.
 - 2. Verify weld materials and inspect welds.
 - 3. Verify connection materials and inspect high-strength bolted connections.
- B. Testing Agency: Owner will engage a qualified testing agency to perform tests and inspections.
- C. Bolted Connections: Inspect and test bolted connections according to RCSC's "Specification for Structural Joints Using High-Strength Bolts."

**NISQUALLY STATE PARK
NEW FULL SERVICE PARK – PHASE 2**

- D. Welded Connections: Visually inspect field welds according to AWS D1.1.
1. In addition to visual inspection, Inspect and test field welds according to AWS D1.1 and the following inspection procedures, at testing agency's option:
 - a. Liquid Penetrant Inspection: ASTM E165.
 - b. Magnetic Particle Inspection: ASTM E709; performed on root pass and on finished weld. Cracks or zones of incomplete fusion or penetration are not accepted.
 - c. Ultrasonic Inspection: ASTM E164.
 - d. Radiographic Inspection: ASTM E94.
- E. In addition to visual inspection, test and inspect field-welded shear connectors according to requirements in AWS D1.1 for stud welding and as follows:
1. Perform bend tests if visual inspections reveal either a less-than-continuous 360 degree flash or welding repairs to any shear connector.
 2. Conduct tests according to requirements in AWS D1.1 on additional shear connectors if weld fracture occurs on shear connectors already tested.

END OF SECTION

**NISQUALLY STATE PARK
NEW FULL SERVICE PARK – PHASE 2**

SECTION 053100 –STEEL DECKING

PART 1 - GENERAL

1.1 SUMMARY

- A. This Section specifies steel decking for Overlook 2.
- B. Related Sections include the following:
 - 1. 033010 Cement Concrete Paving for concrete surfacing for Overlook 2.
 - 2. 033020 Lithomosiatic.

1.2 SUBMITTALS

- A. Product Data: For each type of deck, accessory, and product indicated.
- B. Shop Drawings: Show layout and types of deck panels, gage, anchorage details, reinforcing channels, pans, cut deck openings, special jointing, accessories, attachments, and rib closures, edge forms to other construction. Indicate temporary deck shoring, where required.
- C. Product Certificates: For each type of steel deck, signed by product manufacturer.
- D. Field quality-control test and inspection reports.
- E. Product Test Reports: Based on evaluation of comprehensive tests performed by a qualified testing agency, indicating that each of the following complies with requirements:
 - 1. Power-actuated mechanical fasteners.
- F. Research/Evaluation Reports: ICC Reports as evidence of steel deck's compliance with the International Building Code.

PART 2 - PRODUCTS

2.1 COMPOSITE FLOOR DECK,

- A. Composite Steel Floor Deck: Fabricate panels, with integrally embossed or raised pattern ribs and interlocking side laps, to comply with "SDI Specifications and Commentary for Composite Steel Floor Deck," in SDI Publication No. 30, with the minimum section properties indicated, and with the following:
 - 1. Galvanized Steel Sheet: ASTM A 653, Structural Steel (SS), Grade 33, G90 zinc coating per ASTM A 924 if left permanently exposed. G60 zinc coating in other areas.
 - 2. Galvanized and Shop-Primed Steel Sheet: ASTM A 653, Structural Steel (SS), Grade 33, G60 zinc coating; with unpainted top surface and cleaned and pretreated bottom surface

**NISQUALLY STATE PARK
NEW FULL SERVICE PARK – PHASE 2**

primed with manufacturer's standard white baked-on, rust inhibitive primer. Verify compatibility of primer with top coat.

3. Deck Type: Profile, type, and gage as indicated on Structural Drawings.

PART 3 - EXECUTION

3.1 EXAMINATION

- A. Examine supporting frame and field conditions for compliance with requirements for installation tolerances and other conditions affecting performance.

3.2 INSTALLATION, GENERAL

- A. Install deck panels and accessories according to applicable specifications and commentary in SDI Publication No. 30, manufacturer's written instructions, and requirements in this Section.
- B. Locate deck bundles to prevent overloading of supporting members.
- C. Place deck panels on supporting frame and adjust to final position with ends accurately aligned and bearing on supporting frame before being permanently fastened. Do not stretch or contract side-lap interlocks.
- D. Place deck panels flat and square and fasten to supporting frame without warp or deflection.
- E. Cut and neatly fit deck panels and accessories around openings and other work projecting through or adjacent to deck.
- F. Provide additional reinforcement and closure pieces at openings as required for strength, continuity of deck, and support of other work.
- G. Comply with AWS requirements and procedures for manual shielded metal arc welding, appearance and quality of welds, and methods used for correcting welding work.

3.3 DECK INSTALLATION

- A. Fasten floor-deck panels to steel supporting members by arc spot (puddle) welds of the surface diameter indicated and as follows:
 1. Weld Diameter: 1/2 inch, nominal.
 2. Weld Spacing: Space and locate welds as indicated.
- B. Side-Lap and Perimeter Edge Fastening: Fasten side laps and perimeter edges of panels between supports, at intervals not exceeding the lesser of half of the span or 36 inches, and as follows:
 1. Mechanically fasten with self-drilling, No. 10 diameter or larger, carbon-steel screws.
 2. Mechanically clinch or button punch.
 3. Fasten with a minimum of 1 1/2-inch- long welds.

**NISQUALLY STATE PARK
NEW FULL SERVICE PARK – PHASE 2**

- C. End Bearing: Install deck ends over supporting frame with a minimum end bearing of 1-1/2 inches, with end joints as follows:
 - 1. End Joints: Lapped.
- D. Pour Stops and Girder Fillers: Weld steel sheet pour stops and girder fillers to supporting structure according to SDI recommendations, unless otherwise indicated.
- E. Floor-Deck Closures: Weld steel sheet column closures, cell closures, and Z-closures to deck, according to SDI recommendations, to provide tight-fitting closures at open ends of ribs and sides of deck.
- F. Install piercing hanger tabs at 14 inches apart in both directions, within 9 inches of walls at ends, and not more than 12 inches from walls at sides, unless otherwise indicated.

3.4 REPAIRS AND PROTECTION

- A. Galvanizing Repairs: Prepare and repair damaged galvanized coatings on both surfaces of deck with galvanized repair paint according to ASTM A 780 and manufacturer's written instructions.
- B. Provide final protection and maintain conditions to ensure that steel deck is without damage or deterioration at time of Substantial Completion.

END OF SECTION

**NISQUALLY STATE PARK
NEW FULL SERVICE PARK - PHASE 2**

SECTION 055000 – METAL FABRICATIONS

PART 1 - GENERAL

1.1 DESCRIPTION OF WORK

- A. All metal fabrications are indicated on the Drawings and in the specifications. The work shall consist of furnishing all materials, labor, and equipment for fabricating and/or repairing, and erecting metal fabrications, in accordance with the Drawings, notes, and this specification.

1.2 REFERENCE STANDARDS

- A. American Galvanizers Association (AGA), Quality Assurance Manual.
- B. American Institute of Steel Construction (AISC), Specification for Structural Steel Buildings, 2018.
- C. American Institute of Steel Construction (AISC), Code of Standard Practice for Steel Buildings and Bridges, 2018.
- D. American Society for Testing Materials (ASTM), Standard Specifications and Standard Test Methods, designated by basic reference in this section (use the most current edition at the time of bid unless otherwise indicated).
- E. American Welding Society (AWS) D1.1 – 2015, Structural Welding Code – Steel.
- F. American Welding Society (AWS) A2.4 – 2015, Standard Symbols for Welding, Brazing, and Nondestructive Examination.
- G. Society for Protective Coatings (SSPC), Surface Preparation Specifications.
- H. Washington Association of Building Officials (WABO) Standard No. 27-13, WABO Welder and Welding Operator Performance Qualification Standard for Structural Steel, Sheet Steel, and Reinforcing Steel.

1.3 SUMMARY

- A. Section Includes:
 - 1. Shelf angles.
 - 2. Steel angle corner guards at sectional doors.
 - 3. Pipe and downspout guards.
 - 4. Steel framing
 - 5. CIP concrete
 - 6. Steel decking
 - 7. Steel piles
 - 8. Steel anchor plates
 - 9. Tube Steel

**NISQUALLY STATE PARK
NEW FULL SERVICE PARK - PHASE 2**

- B. Related Requirements:
1. Section 033000 – Cast-in-Place Concrete
 2. Section 051200 - Structural Steel Framing
 3. Section 053100 - Steel Decking
 4. Section 061316 – Pole Construction, for pole connectors.
 5. Section 133700 – Boardwalk
 6. Section 136000 - Kiosks
 7. Section 316216 - Steel Piles

1.4 ADMINISTRATIVE REQUIREMENTS

- A. Coordination:
1. Coordinate selection of shop primers with topcoats to be applied over them.
 - a. Comply with paint and coating manufacturers' written recommendations to ensure that shop primers and topcoats are compatible with one another.
 2. Coordinate installation of metal fabrications that are anchored to or that receive other Work.
 - a. Furnish setting drawings, templates, and directions for installing anchorages, including sleeves, concrete inserts, anchor bolts, and items with integral anchors, that are to be embedded in concrete or masonry.
 - b. Deliver such items to Project site in time for installation.
 3. Provide detailed and coordinated shop drawings indicating all shop and erection details, including cuts, copes, connections, holes, fasteners, material specifications, welds, surface preparations, and finishes.

1.5 ACTION SUBMITTALS

- A. Product Data: For the following:
1. Fasteners.
 2. Shop primers.
 3. Shelf angles.
 4. Steel angle corner guards at sectional doors.
 5. Downspout guards.
- B. Shop Drawings: Show fabrication and installation details. Include plans, elevations, sections, and details of metal fabrications and their connections. Show anchorage and accessory items. Provide Shop Drawings for the following:
1. Shelf angles.
 2. Steel angle corner guards at sectional doors.
 3. Downspout guards.
 4. Submit Shop Drawings that have been engineered and certified by professional engineer licensed in the State in which Project is located.
 - a. Include seal and signature of professional engineer on Shop Drawings.
 - b. Provide detailed and coordinated shop drawings indicating all shop and erection details, including cuts, copes, connections, holes, fasteners, material specifications, welds, surface preparations, and finishes.

**NISQUALLY STATE PARK
NEW FULL SERVICE PARK - PHASE 2**

1.6 INFORMATIONAL SUBMITTALS

- A. Welding qualifications and certificates.
- B. Weld Procedure Specifications (WPS's) proposed for use on the project. Submit supporting Procedure Qualification Records (PQR's) for all WPS's not prequalified by AWS.
- C. Paint Compatibility Certificates: From manufacturers of topcoats applied over shop primers, certifying that shop primers are compatible with topcoats.
- D. Steel Primer Certification: From steel fabricator for specific surface preparation procedures and primers used for fabricated steel items to verify compliance with Specifications and compatibility of finish coat materials.
- E. Galvanized coating applicator's Certificate of Compliance that the hot-dip galvanized coatings meets or exceed the specified requirements of ASTM A 123 or A 153, as applicable, and has followed the procedures in the AGA Quality Assurance Manual.
- F. Mill certificates for each heat number of structural and miscellaneous steel.

1.7 QUALITY ASSURANCE

- A. Demonstrate that the fabricator has a minimum of five (5) years of experience fabricating and working similar metals and configurations, including cutting, bending, forming, welding, and finishing.
- B. Welders shall be currently certified by the Washington Association of Building Officials (WABO) for structural welding.
- C. Welding procedures, operations, welders, and tackers shall be qualified in accordance with AWS D1.1.
- D. The galvanized coating applicator shall specialize in hot-dip galvanizing after fabrication and follow the procedures in the AGA Quality Assurance Manual.
- E. Nondestructive testing (NDT) and inspection of all shop and field welds will be performed in accordance with AWS D1.1 by an independent testing agency. Welds failing to comply shall be repaired or replaced at the Contractor's expense.
- F. Welding Qualifications: Qualify procedures and personnel according to the following:
 - 1. AWS D1.1.
 - 2. Use welders certified by AWS and the State in which Project is located for structural welding, and who have undergone recertification in the last 12 months.

**NISQUALLY STATE PARK
NEW FULL SERVICE PARK - PHASE 2**

PART 2 - PRODUCTS

2.1 GENERAL

- A. All products shall be new, free from oxidation, corrosion, and defects, and shall be of the specified quality.
- B. Protect all materials and fabrications before, during, and after installation from damage. Protect the installed work of other trades from damage.
- C. Protect galvanized finishes and painted coatings from damage by use of padded slings and straps.
- D. In the event of damage, immediately make all repairs and replacements as per the manufacturer's written recommendations and as approved by the Engineer at no additional cost to the Port.

2.2 PERFORMANCE CRITERIA

- A. Thermal Movements: Allow for thermal movements from ambient and surface temperature changes acting on exterior metal fabrications by preventing buckling, opening of joints, overstressing of components, failure of connections, and other detrimental effects.
 - 1. Temperature Change: 120 deg F, ambient; 180 deg F, material surfaces.

2.3 METALS

- A. Metal Surfaces, General: Provide materials with smooth, flat surfaces unless otherwise indicated. For metal fabrications exposed to view in completed Work, provide materials without seam marks, roller marks, rolled trade names, or blemishes.
- B. All miscellaneous steel shapes and plates shall conform to ASTM A36, unless otherwise noted.
- C. Tube steel: ASTM A36
- D. Splice plates and steel plates noted as Grade 50, shall conform to ASTM A572.
- E. Angles and channels: ASTM A36
- F. HSS section: ASTM A500, Grade C
- G. W-shapes: ASTM A992
- H. Metallic-Coated Steel Sheet: ASTM A653, CS (Commercial Steel), Type B; with A60 zinc-iron-alloy (galvannealed) coating designation.
- I. Cast Iron: Either gray iron, ASTM A48, or malleable iron, ASTM A47, unless otherwise indicated.

**NISQUALLY STATE PARK
NEW FULL SERVICE PARK - PHASE 2**

2.4 FASTENERS

- A. Unless otherwise indicated, provide Type 304 stainless steel fasteners for exterior use and zinc-plated fasteners with coating complying with ASTM B633 or ASTM F1941, Class Fe/Zn 5, at exterior walls.
 - 1. Select fasteners for type, grade, and class required.
- B. Steel Bolts and Nuts: Regular hexagon-head bolts, ASTM A307, Grade A; with hex nuts, ASTM A563; and, where indicated, flat washers.
- C. Stainless Steel Bolts and Nuts: Regular hexagon-head annealed stainless-steel bolts, ASTM F593; with hex nuts, ASTM F594; and, where indicated, flat washers; Alloy Group 1.
- D. Anchor Bolts: ASTM F1554, Grade 55, of dimensions indicated; with nuts, ASTM A563; and, where indicated, flat washers.
 - 1. Provide hot-dip galvanized or mechanically deposited, zinc coating where item being fastened is indicated to be galvanized.
- E. Anchors, General: Capable of sustaining, without failure, a load equal to 4 times load imposed when installed in concrete and 6 times load imposed when installed in unit masonry, as determined by testing per ASTM E488, conducted by a qualified independent testing agency.
- F. Cast-in-Place Anchors in Concrete: Either threaded type or wedge type unless otherwise indicated; galvanized ferrous castings, either ASTM A47 malleable iron or ASTM A27 cast steel. Provide bolts, washers, and shims as needed, all hot-dip galvanized per ASTM F2329.
- G. Post-Installed Anchors: Torque-controlled expansion anchors or chemical anchors.
 - 1. Material for Interior Locations: Carbon-steel components zinc plated to comply with ASTM B633 or ASTM F1941, Class Fe/Zn 5, unless otherwise indicated.
 - 2. Material for Exterior Locations and Where Stainless Steel is Indicated: ASTM F593, Alloy Group 1 stainless steel bolts, and ASTM F594, Alloy Group 1 or 2 stainless steel nuts.
- H. Blind Bolts: All blind bolts shall be Lindapter LHBM20 #1 HDG or approved equal.
- I. Epoxy or adhesive-type anchors shall be HILTI-HIT RE500 V3 or approved equal.

2.5 MISCELLANEOUS MATERIALS

- A. Steel Primers:
 - 1. Provide primers that comply with Section 099600 – High-Performance Coatings.

2.6 FABRICATION, GENERAL

- A. Shop Assembly: Preassemble items in shop to greatest extent possible.
 - 1. Disassemble units only as necessary for shipping and handling limitations.
 - 2. Use connections that maintain structural value of joined pieces.
 - 3. Clearly mark units for reassembly and coordinated installation.

**NISQUALLY STATE PARK
NEW FULL SERVICE PARK - PHASE 2**

- B. Cut, drill, and punch metals cleanly and accurately.
 - 1. Remove burrs and ease edges to a radius of approximately 1/32 inch unless otherwise indicated.
 - 2. Remove sharp or rough areas on exposed surfaces.
- C. Form bent-metal corners to smallest radius possible without causing grain separation or otherwise impairing Work.
- D. Form exposed Work with accurate angles and surfaces and straight edges.
- E. Weld corners and seams continuously to comply with the following:
 - 1. Use materials and methods that minimize distortion and develop strength and corrosion resistance of base metals.
 - 2. Obtain fusion without undercut or overlap.
 - 3. Remove welding flux immediately.
 - 4. At exposed connections, finish exposed welds and surfaces smooth and blended so no roughness shows after finishing.
- F. Form exposed connections with hairline joints, flush and smooth, using concealed fasteners or welds where possible. Where exposed fasteners are required, use Phillips flat-head (countersunk) fasteners unless otherwise indicated. Locate joints where least conspicuous.
- G. Fabricate seams and other connections that are exposed to weather in a manner to exclude water. Provide weep holes where water may accumulate.
- H. Cut, reinforce, drill, and tap metal fabrications as indicated to receive finish hardware, screws, and similar items.
- I. Provide for anchorage of type indicated. Coordinate with supporting structure. Space anchoring devices to secure metal fabrications rigidly in place and to support indicated loads.
- J. Where units are indicated to be cast into concrete or built into masonry, equip with integrally welded steel strap anchors, 1/8 by 1-1/2 inches, with a minimum 6 inch embedment and 2 inch hook, not less than 8 inches from ends and corners of units and 24 inches on center, unless otherwise indicated.

2.7 SHELF ANGLES

- A. Fabricate shelf angles from steel angles of sizes indicated and for attachment to concrete framing. Provide horizontally slotted holes to receive 3/4 inch bolts, spaced not more than 6 inches from ends and 24 inches on center, unless otherwise indicated.
 - 1. Provide mitered and welded units at corners.
 - 2. Provide open joints in shelf angles at expansion and control joints. Make open joint approximately 2 inches larger than expansion or control joint.
- B. For cavity walls, provide vertical channel brackets to support angles from backup masonry and concrete.
- C. Galvanize shelf angles located in exterior walls.

**NISQUALLY STATE PARK
NEW FULL SERVICE PARK - PHASE 2**

- D. Furnish wedge-type concrete inserts, complete with fasteners, to attach shelf angles to cast-in-place concrete, if not specified in Section 033000 Cast-in-Place Concrete.

2.8 MISCELLANEOUS STEEL

- A. Unless otherwise indicated, fabricate units from steel shapes, plates, and bars of profiles shown with continuously welded joints and smooth exposed edges. Miter corners and use concealed field splices where possible.
- B. Provide cutouts, fittings, and anchorages as needed to coordinate assembly and installation with other Work.
- C. Galvanize and prime exterior miscellaneous steel.

2.9 DOWNSPOUT GUARDS

- A. Fabricate downspout guards from 3/8 inch thick by 12 inchwide steel plate, bent to fit flat against wall or column at both ends and to fit around pipe with 2 inch clearance between pipe and pipe guard. Drill each end for two 3/4 inch anchor bolts.
- B. Galvanize and prime downspout guards.
- C. Prime downspout guards with primer specified in Section 099600 – High-Performance Coatings.

2.10 FINISHES, GENERAL

- A. Finish metal fabrications after assembly.
- B. Finish exposed surfaces to remove tool and die marks and stretch lines, and to blend into surrounding surface.

2.11 STEEL AND IRON FINISHES

- A. Galvanizing: Hot-dip galvanize items as indicated to comply with ASTM A153 for steel and iron hardware and with ASTM A123 for other steel and iron products.
 - 1. Do not quench or apply post galvanizing treatments that might interfere with paint adhesion.
- B. Shop prime iron and steel items unless they are to be embedded in concrete, masonry, or unless otherwise indicated.
 - 1. Shop prime with universal shop primer unless primers specified in Section 099600 – High-Performance Coatings are indicated.
- C. Preparation for Shop Priming: Prepare surfaces to comply with requirements indicated below:
 - 1. SSPC-SP 3: Interior Steel.
 - 2. SSPC-SP 6/NACE No. 3: Exterior steel; steel indicated to receive high-performance coatings.

**NISQUALLY STATE PARK
NEW FULL SERVICE PARK - PHASE 2**

- D. Shop Priming: Apply shop primer to comply with SSPC-PA 1, "Paint Application Specification No. 1: Shop, Field, and Maintenance Painting of Steel," for shop painting.
 - 1. Stripe paint corners, crevices, bolts, welds, and sharp edges.

PART 3 - EXECUTION

3.1 PREPARATORY REVIEW

- A. Prior to all work of this section, inspect the installed work of all other trades affecting this work and verify that all such work is complete to the point where this installation may commence.
- B. Coordinate and furnish placement drawings, templates, instructions, and directions for installation of embedded anchorages, including concrete inserts, sleeves, anchor bolts, and miscellaneous items.
- C. Verify that the work can be fabricated and installed in accordance with the Drawings, specifications, and reference standards. Immediately report discrepancies to the Engineer and do not proceed with fabrication or installation until discrepancies are resolved and direction is provided.

3.2 INSTALLATION, GENERAL

- A. Cutting, Fitting, and Placement: Perform cutting, drilling, and fitting required for installing metal fabrications. Set metal fabrications accurately in location, alignment, and elevation; with edges and surfaces level, plumb, true, and free of rack; and measured from established lines and levels.
- B. Fit exposed connections accurately together to form hairline joints. Weld connections that are not to be left as exposed joints but cannot be shop welded because of shipping size limitations. Do not weld, cut, or abrade surfaces of exterior units that have been hot-dip galvanized after fabrication and are for bolted or screwed field connections.
- C. Field Welding: Comply with the following requirements:
 - 1. Use materials and methods that minimize distortion and develop strength and corrosion resistance of base metals.
 - 2. Obtain fusion without undercut or overlap.
 - 3. Remove welding flux immediately.
 - 4. At exposed connections, finish exposed welds and surfaces smooth and blended so no roughness shows after finishing and contour of welded surface matches that of adjacent surface.
- D. Fastening to In-Place Construction: Provide anchorage devices and fasteners where metal fabrications are required to be fastened to in-place construction. Provide threaded fasteners for use with concrete and masonry inserts, toggle bolts, through bolts, lag screws, wood screws, and other connectors.
- E. Provide temporary bracing or anchors in formwork for items that are to be built into concrete, masonry, or similar construction.

**NISQUALLY STATE PARK
NEW FULL SERVICE PARK - PHASE 2**

3.3 FABRICATION

- A. All structural steel shall be fabricated in accordance with the approved shop drawings and reference standards.
- B. Shop-fabricate and preassemble all items complete for installation to the extent practicable to minimize field assembly. Disassemble units only as necessary for shipping and handling limitations.
- C. Weld all shop connections unless otherwise directed on the Drawings. All joints shall be tightly fitting, securely fastened, square, plumb, straight, and true.
- D. Drill or punch all holes required for attachments and bolted connections including those of other trades. Burned holes are not acceptable.
- E. Welding of all metal fabrications shall conform to AWS D1.1.
- F. Install and erect all miscellaneous metal and metal fabrications in accordance with the design drawings, shop drawings, and reference standards.

3.4 INSTALLATION OF DOWNSPOUT GUARDS

- A. Provide downspout guards at exposed vertical downspouts at locations indicated on Drawings where not protected by curbs or other barriers.
 - 1. Install by bolting to wall or column with expansion anchors.
 - 2. Provide four 3/4 inch bolts at each pipe guard.
 - 3. Mount downspout guards with top edge 26 inches above driving surface.

3.5 REPAIRS

- A. Touchup Painting:
 - 1. Immediately after erection, clean field welds, bolted connections, and abraded areas.
 - a. Paint uncoated and abraded areas with same material as used for shop painting to comply with SSPC-PA 1 for touching up shop-painted surfaces.
 - b. Apply by brush or spray to provide a minimum 2.0 mil dry film thickness.
 - 2. Cleaning and touchup painting of field welds, bolted connections, and abraded areas of shop paint are specified in Section 099600 – High-Performance Coatings.
- B. Galvanized Surfaces: Clean field welds, bolted connections, and abraded areas, and repair with galvanizing repair coating.

END OF SECTION

**NISQUALLY STATE PARK
NEW FULL SERVICE PARK – PHASE 2**

SECTION 055200 – PIPE HANDRAIL

PART 1 - GENERAL

1.1 DESCRIPTION

- A. This section applies to the Pipe Handrail located at stairs, ramps, and boardwalk ramps.

1.2 PERFORMANCE REQUIREMENTS

- A. Structural Performance of Pipe Handrails:

1. Comply with ASTM E 985, based on testing per ASTM E 894 and ASTM E 935.
2. Capable of withstanding structural loads required by ASCE 7 without exceeding allowable design working stresses of materials involved.
3. Capable of withstanding the following structural loads without exceeding the allowable design working stress of materials involved:
 - a. Top Rail of Guards: Concentrated load of 200 lbf (890 N) applied at any point and in any direction, and a uniform load of 50 lbf/ft. (730 N/m) applied horizontally and concurrently with uniform load of 100 lbf/ft. (1460 N/m) applied vertically downward. Concentrated and uniform loads need not be assumed to act concurrently.
 - b. Handrails Not Serving as Top Rails: Concentrated load of 200 lbf (890 N) applied at any point and in any direction, and a uniform load of 50 lbf/ft. (730 N/m) applied in any direction. Concentrated and uniform loads need not be assumed to act concurrently.
 - c. Infill Area of Guards: Horizontal concentrated load of 200 lbf (890 N) applied to 1 sq. ft. (0.09 sq. m) at any point in system, including panels, intermediate rails, balusters, or other elements composing infill area. Load on infill area need not be assumed to act concurrently with loads on top rails.
 - d. All welding shall be performed by a certified WABO welder. Copy of certification shall remain on site during construction.

- B. Handrails shall comply with the Americans with Disabilities Act and the International Building Code.

1.3 SUBMITTALS

- A. Product Data: For all products in this Section.
- B. Shop Drawings: Include plans, elevations, sections, details of installation, attachments to other Work.
1. Include structural analysis data signed and sealed by the qualified professional engineer responsible for their preparation.

**NISQUALLY STATE PARK
NEW FULL SERVICE PARK – PHASE 2**

PART 2 - PRODUCTS

2.1 MANUFACTURERS

- A. Available Manufacturers: Subject to compliance with requirements, manufacturers offering products that may be incorporated into the Work include, but are not limited to, the following:
 - 1. Pipe Handrail:
 - a. Wagner, R & B, Inc.

2.2 METALS

- A. Steel and Iron:
 - 1. Steel Pipe Handrails: ASTM A 53, Type F or Type S, Grade A, standard weight (Schedule 40), unless another grade and weight are required by structural loads.
 - a. Galvanized finish for exterior installations and where indicated.
- B. Steel Plates: ASTM A283.

2.3 MISCELLANEOUS MATERIALS

- A. Welding Electrodes and Filler Metal: Provide type and alloy as recommended by producer of metal to be welded and as required for color match, strength, and compatibility in fabricated items.
- B. Galvanized Paint: Galvanized Paint shall be ZRC Galvilite Bright Silver Cold Galvanizing by CME Supply (718.210.3913) or approved equal. Galvanize Paint shall be single component, meets and exceeds galvanizing repair specifications ASTM Des. A 780, SSPC-Paint 20 and DOD-P-21035A and shall meet USA VOC standards. Galvanize Paint shall meet and exceed SSPC-Paint 20 and 29.

2.4 HANDRAIL END CAP

- A. Handrail End Caps shall be a flat galvanized steel end cap for 2” diameter steel pipe handrail. Provide an end cap at all open ends of the steel pipe handrail.

2.5 FABRICATION

- A. General: Fabricate to design, dimensions, and details indicated, but not less than that required to support structural loads. Prevent galvanic action and other forms of corrosion by insulating metals and other materials from direct contact with incompatible materials.
- B. Form changes in direction of railing members by bending.

**NISQUALLY STATE PARK
NEW FULL SERVICE PARK – PHASE 2**

- C. Form curves by bending in jigs to produce uniform curvature without buckling, twisting, cracking, or otherwise deforming exposed surfaces.
 - 1. Welded Connections: Connect handrail and railing members by welding. Cope and weld or use welded-in fittings. Weld connections continuously. Grind smooth all welds and all surfaces prior to galvanizing.
 - 2. Ease all edges.

2.6 FINISHES

- A. Steel: Galvanized Finish, Hot dip galvanize after fabrication to comply with ASTM A 123. Provide minimum 1.25 oz/sq. ft galvanized coating.

2.7 GROUT

- A. Grout shall be QUIKRETE® Non-Shrink Precision Grout (No. 1585-00) or approved equal.

2.8 WEDGE ANCHORS

- A. Wedge Anchors shall be Wedge-Bolt 410 stainless steel complying with ASTM E488 and AC 106 with a Class 4 Sealcoat as manufactured by Powers Fasteners or approved equal. Wedge Bolts diameter shall be sized as required by site furnishing manufacturers and embedment length shall be as shown on the Plans. Wedge-Bolt shall have the bolt diameter and length clearly stamped on the hex head.

2.9 HANDRAIL BRACKET

- A. Hardware for mounting 2” O.D. galvanized steel pipe handrails shall be Heavy Duty Handrail Mounting Bracket, galvanized steel, MCMASTER-CA 5144N15. O.A.E

PART 3 - EXECUTION

3.1 INSTALLATION, GENERAL

- A. Fit exposed connections together to form tight, hairline joints.
- B. Perform cutting, drilling, and fitting required for installing railings. Set railings accurately in location, alignment, and elevation; measured from established lines and levels and free of rack.
 - 1. Do not weld, cut, or abrade surfaces of railing components that have been coated or finished after fabrication and that are intended for field connection by mechanical or other means without further cutting or fitting.
 - 2. Set posts plumb within a tolerance of 1/16 inch in 3 feet (2 mm in 1 m).
 - 3. Align rails so variations from level for horizontal members and variations from parallel with rake of steps and ramps for sloping members do not exceed 1/4 inch in 12 feet (5 mm in 3 m).

**NISQUALLY STATE PARK
NEW FULL SERVICE PARK – PHASE 2**

- C. Adjust railings before anchoring to ensure matching alignment at abutting joints. Install plumb and level with zero lateral or vertical movement.

3.2 POST & RAIL CONNECTIONS

- A. Welded Connections: Use fully welded joints for permanently connecting post and rail components. Comply with requirements for welded connections in "Fabrication" Article whether welding is performed in the shop or in the field.
- B. Expansion Joints: Install expansion joints at locations indicated but not farther apart than required to accommodate thermal movement. Provide slip-joint internal sleeve extending 2 inches beyond joint on either side, fasten internal sleeve securely to one side, and locate joint within 6 inches of post.

3.3 HANDRAIL END CAP

- A. Welded Connections: Use continuous weld for permanently connecting end cap to handrail. Comply with requirements for welded connections in "Fabrication" Article whether welding is performed in the shop or in the field.

3.4 ANCHORING POSTS

- A. Anchor posts as indicated on Drawings, unless noted otherwise. All Handrails shall be installed plumb.
- B. Railings for Handrail shall be installed true to line with no horizontal and vertical irregularities. Drill holes for Wedge Anchors shall be drilled in Cement Concrete Pavement the same diameter as Wedge Anchor diameter.

3.5 ADJUSTING AND CLEANING

- A. Touchup Galvanizing Painting: Clean all grease off of hot dipped galvanized surfaces. Wipe all surfaces clean and dry prior to galvanized paint application. Apply Galvanizing Paint to abraded and scratched areas of galvanized finish. Apply by brush or spray to provide a minimum 2.0-mil (0.05-mm) dry film thickness.

3.6 PROTECTION

- A. Protect finishes of post and railings from damage during construction period.

END OF SECTION

**NISQUALLY STATE PARK
NEW FULL SERVICE PARK – PHASE 2**

SECTION 060573 –WOOD TREATMENT

PART 1 - GENERAL

1.1 SECTION INCLUDES

- A. Preservative treatment of lumber and plywood.

1.2 RELATED SECTIONS

- A. Section 061000 – Rough Carpentry
- B. Section 133700 – Boardwalk
- C. Section 136000 – Kiosks
- D. Section 138000 – Horse Mounting Block
- E. Section 323119 – Privacy Fence

1.3 REFERENCES

- A. ASTM International (ASTM):
 - 1. ASTM A153/A153M - Standard Specification for Zinc Coating (Hot-Dip) on Iron and Steel Hardware.
 - 2. ASTM A653 / A653M - Standard Specification for Steel Sheet, Zinc-Coated (Galvanized) or Zinc-Iron Alloy-Coated (Galvannealed) by the Hot-Dip Process.
- B. American Wood-Protection Association (AWPA):
 - 1. AWPA E12 - Standard Method of Determining the Corrosion of Metal in Contact with Wood.
 - 2. AWPA M4 - Standard for the Care of Preservative Treated Wood Products.
 - 3. AWPA P48 - Standard for Copper Azole Type C (CA-C).
 - 4. AWPA T1 - Use Category System: Processing and Treatment Standard.
 - 5. AWPA U1 - Use Category System: User Specification for Treated Wood.

1.4 SUBMITTALS

- A. Submit under provisions of Section 013000 - Administrative Requirements.
- B. Product Data: Manufacturer's instructions for use, including requirements for storage, cutting, and finishing.

**NISQUALLY STATE PARK
NEW FULL SERVICE PARK – PHASE 2**

- C. Preservative Treatment Certification: Treating plant's certification of compliance with specified standards, process employed, and preservative retention values.

1.5 QUALITY ASSURANCE

- A. Wood Treatment Plant Qualifications: Wood treatment plant experienced in performing work of this section licensed by Viance, LLC.
- B. Source Quality: Obtain treated wood products from a single approved source.
- C. Preservative Treatment: Mark each piece of plywood and lumber to show compliance with specified standards.
- D. Independent Third Party Inspection: Provide plant inspections.
- E. Kiln Dry after Treatment (KDAT): Provide kiln dry material as indicated or required.
 - 1. Lumber: To 19 percent maximum moisture content in accordance with AWWA T1, Section 7 - Drying After Treatment.
 - 2. Plywood: To 18 percent maximum moisture content in accordance with AWWA T1, Section F - Pressure treated composites (3c) kiln drying after treatment.

1.6 DELIVERY, STORAGE, AND HANDLING

- A. Exposure: Prevent wood products against moisture and dimensional changes, in accordance with instructions from treating plant.

1.7 WARRANTY

- A. Preserve CA Manufacturer's Warranty: Provide manufacturer's standard lifetime limited warranty for pressure treated wood.

PART 2 - PRODUCTS

2.1 MANUFACTURERS

- A. Acceptable Manufacturer: Viance - Treated Wood Solutions, which is located at: 8001 IBM Dr. Building 403; Charlotte, NC 28262; Toll Free Tel: 800-421-8661; Tel: 704-522-0825; Fax: 704-527-8232; Email: request info (Productinfo@viance.net); Web: <https://treatedwood.com>
- B. Acceptable Supplier: Superior Wood Treating, which is located at: 13702 Stewart Rd. Sumner, WA 98390; Toll Free: 1-800-422-3120; Web: www.superiorwoodtreating.com
- C. Requests for substitutions will be considered in accordance with provisions of Section 016000 - Product Requirements.

**NISQUALLY STATE PARK
NEW FULL SERVICE PARK – PHASE 2**

2.2 MATERIALS

- A. Dimension Lumber: As specified in Sections:
 - 1. Section 061000 – Rough Carpentry
 - 2. Section 133700 – Boardwalk
 - 3. Section 136000 – Kiosks
 - 4. Section 138000 – Horse Mounting Block
 - 5. Section 323119 – Privacy Fence
- B. Structural Plywood: As specified in Section 136000 – Kiosks.
- C. Fasteners and Metal Hardware in Preservative Treated Wood: For treated wood and where wood is in ground contact, subject to high relative humidity, or exposed to weather, provide corrosion resistant steel fasteners with hot-dip zinc coating per ASTM A153/A153M, provide corrosion resistant hardware per ASTM A653 / A653M Class G-185 in compliance with building code requirements.

2.3 PRESERVATIVE PRESSURE TREATMENT OF WOOD

- A. Preservative Pressure Treatment for Above Ground Use: Boardwalk and Kiosk Wood (UC3B).
 - 1. Treatment: Preserve CA-C as manufactured by Viance.
 - a. Use 0.060 lbs per cu ft (1.0 kg per cu m) of CA-C in accordance with AWPA U1: (UC3B) as appropriate.
- B. Preservative Pressure Treatment for Wood in Ground Contact (UC4A):
 - 1. Treatment: Preserve CA-C as manufactured by Viance.
 - a. Use .31 lbs per cu ft (5.0 kg per cu m) retention in accordance with AWPA U1 (UC4C) as appropriate.
 - 2. If required, kiln dry after treatment to 19 percent maximum moisture content for lumber and 18 percent for plywood.

PART 3 - EXECUTION

- A. Preservative Treated Wood:
 - 1. Surface Treatment of Field Cuts: All field cuts on members that provide structural support to a permanent structure shall be field treated in accordance with AWPA M4.

END OF SECTION

**NISQUALLY STATE PARK
NEW FULL SERVICE PARK – PHASE 2**

SECTION 061000 – ROUGH CARPENTRY

PART 1 - GENERAL

1.1 SUMMARY

A. Section Includes:

1. Framing with dimension lumber.
2. Framing with engineered wood products.
3. Wood blocking and nailers.
4. Wood furring.
5. Plywood backing panels.

1.2 ACTION SUBMITTALS

A. Product Data: For each type of process and factory-fabricated product.

1. Indicate component materials and dimensions. Include construction and application details.
2. Include data for wood-preservative treatment from chemical treatment manufacturer and certification by treating plant that treated materials comply with requirements. Indicate type of preservative used and net amount of preservative retained.
3. Include data for fire-retardant treatment from chemical treatment manufacturer and certification by treating plant that treated materials comply with requirements. Include physical properties of treated materials based on testing by a qualified independent testing agency.
4. For fire-retardant treatments, include physical properties of treated lumber both before and after exposure to elevated temperatures, based on testing by a qualified independent testing agency according to ASTM D5664.
5. For products receiving a waterborne treatment, include statement that moisture content of treated materials was reduced to levels specified before shipment to Project site.

B. Fastener Patterns: Full-size templates for fasteners in exposed framing.

1.3 INFORMATIONAL SUBMITTALS

A. Material Certificates:

1. For dimension lumber specified to comply with minimum allowable unit stresses. Indicate species and grade selected for each use and design values approved by the ALSC Board of Review.
2. For preservative-treated wood products. Indicate type of preservative used and net amount of preservative retained.

B. Evaluation Reports: For the following, from ICC-ES:

**NISQUALLY STATE PARK
NEW FULL SERVICE PARK – PHASE 2**

1. Preservative-treated wood products.
2. Fire-retardant-treated wood products.
3. Engineered wood products.
4. Power-driven fasteners.
5. Post-installed anchors.
6. Metal framing anchors.

1.4 QUALITY ASSURANCE

- A. Testing Agency Qualifications: For testing agency providing classification marking for fire-retardant treated material, an inspection agency acceptable to AHJ that periodically performs inspections to verify that materials bearing classification marking is representative of material tested.

1.5 DELIVERY, STORAGE, AND HANDLING

- A. Stack wood products flat with spacers beneath and between each bundle to provide air circulation. Protect wood products from weather by covering with waterproof sheeting, securely anchored. Provide for air circulation around stacks and under coverings.

PART 2 - PRODUCTS

2.1 WOOD PRODUCTS, GENERAL

- A. Lumber: Comply with DOC PS 20 and with applicable rules of grading agencies indicated. If no grading agency is indicated, comply with applicable rules of any rules-writing agency certified by ALSC Board of Review. Grade lumber by an agency certified by ALSC Board of Review to inspect and grade lumber under rules indicated.
 1. Factory mark each piece of lumber with grade stamp of grading agency.
 2. Dress lumber, S4S, unless otherwise indicated.
- B. Maximum Moisture Content of Lumber:
 1. 2 Inch Nominal Thickness or Less: 15 percent.
 2. More Than 2 Inch Nominal Thickness: 19 percent unless otherwise indicated.
- C. Engineered Wood Products: Acceptable to authorities having jurisdiction and for which current model code research or evaluation reports exist that show compliance with building code in effect for Project.
 1. Allowable design stresses, as published by manufacturer, shall meet or exceed those indicated. Manufacturer's published values shall be determined from empirical data or by rational engineering analysis and demonstrated by comprehensive testing performed by a qualified independent testing agency.
- D. Lumber fabricated from old growth timber is not permitted.

**NISQUALLY STATE PARK
NEW FULL SERVICE PARK – PHASE 2**

2.2 PRESERVATIVE-TREATED WOOD MATERIALS

- A. Preservative Treatment: Pressure-treat rough carpentry indicated as PT with waterborne preservative according to AWPA U1, Use Categories as follows:
 - 1. UC2: Interior lumber not in contact with ground but may be subject to moisture.
 - a. Includes wood in contact with concrete and masonry.
 - 2. UC3b: Exterior lumber not in contact with ground.
 - 3. UC4a: Exterior lumber in contact with ground.
- B. Preservative Chemicals: Acceptable to AHJ and containing no arsenic or chromium.
 - 1. Do not use inorganic boron (SBX) for sill plates.
- C. For exposed items indicated to receive a stained or natural finish, use chemical formulations that do not contain colorants, bleed through, or otherwise adversely affect finishes.
- D. Kiln-dry lumber after treatment to a maximum moisture content of 19 percent. Do not use material that is warped or that does not comply with requirements for untreated material.
- E. Mark lumber with treatment quality mark of an inspection agency approved by ALSC Board of Review.
- F. Application: Treat items indicated on Drawings as PT, and the following:
 - 1. Concealed rough carpentry wood members in contact with masonry or concrete.
 - 2. Wood framing and furring attached directly to interior of below-grade exterior masonry or concrete walls.
 - 3. Wood framing members that are less than 18 inches above ground in crawlspaces or unexcavated areas.
 - 4. Wood floor plates that are installed over concrete slabs-on-grade.

2.3 FIRE-RETARDANT-TREATED MATERIALS

- A. Where fire-retardant-treated materials are indicated, materials shall comply with requirements in this Article, that are acceptable to AHJ, and with fire-test-response characteristics specified as determined by testing identical products per test method indicated by a qualified testing agency.
- B. Fire-Retardant-Treated Lumber and Plywood by Pressure Process: Products with a flame-spread index of 25 or less when tested according to ASTM E84, and with no evidence of significant progressive combustion when the test is extended an additional 20 minutes, and with flame front not extending more than 10.5 feet beyond centerline of burners at any time during test.
 - 1. Treatment shall not promote corrosion of metal fasteners.
 - 2. Exterior Type: Treated materials shall comply with requirements specified above for fire-retardant-treated lumber and plywood by pressure process after being subjected to accelerated weathering according to ASTM D2898.

**NISQUALLY STATE PARK
NEW FULL SERVICE PARK – PHASE 2**

- a. Application: Exterior locations and where indicated, including wood members associated with roof deck assemblies.
- 3. Interior Type A: Treated materials shall have a moisture content of 28 percent or less when tested according to ASTM D3201 at 92 percent relative humidity.
 - a. Application: Where exterior type is not indicated.
- C. Kiln-dry lumber after treatment to maximum moisture content of 19 percent. Kiln-dry plywood backing panels after treatment to maximum moisture content of 15 percent.
- D. Identify fire-retardant-treated wood with appropriate classification marking of qualified testing and inspecting agency acceptable to AHJ.
 - 1. Omit marking and provide certificates of treatment compliance issued by testing and inspection agency if acceptable to AHJ.
- E. For exposed items indicated to receive a stained or natural finish, chemical formulations shall not bleed through, contain colorants, or otherwise adversely affect finishes.
- F. Application: Treat items indicated on Drawings, and the following:
 - 1. Concealed blocking.
 - 2. Framing for non-load-bearing partitions.
 - 3. Framing for non-load-bearing exterior walls.
 - 4. Roof construction.
 - 5. Plywood backing panels.

2.4 DIMENSION LUMBER FRAMING

- A. Non-Load-Bearing Interior Partitions: Construction or No. 2 grade.
 - 1. Species: Douglas fir-larch; WCLIB or WWPA.
 - 2. Application: Interior, non-load-bearing partitions.
- B. Load-Bearing Partitions: Construction or No. 2 grade.
 - 1. Species: Douglas fir-larch; WCLIB or WWPA unless indicated otherwise on Drawings.
 - 2. Application: Exterior walls and interior load-bearing partitions.
- C. Joists, Rafters, and Other Framing Not Listed Above: Construction or No. 2 grade.
 - 1. Species: As indicated on structural Drawings.
- D. Joists, Rafters, and Other Framing Not Listed Above: Any species and grade with a modulus of elasticity of at least 1,300,000 psi and an extreme fiber stress in bending of at least 1,300 psi for 2 inch nominal thickness and 12 inch nominal width for single-member use.

**NISQUALLY STATE PARK
NEW FULL SERVICE PARK – PHASE 2**

2.5 ENGINEERED WOOD PRODUCTS

- A. Source Limitations: Obtain each type of engineered wood product from single source from a single manufacturer.

- B. Laminated-Veneer Lumber: Structural composite lumber made from wood veneers with grain primarily parallel to member lengths, evaluated and monitored according to ASTM D5456 and manufactured with an exterior-type adhesive complying with ASTM D2559.
 - 1. Manufacturers: Subject to compliance with requirements, provide products by one of the following:
 - a. Boise Cascade Corporation.
 - b. Georgia-Pacific Building Products.
 - c. LP Building Products.
 - d. Pacific Woodtech Corporation.
 - e. RedBuilt, LLC.
 - f. Roseburg Forest Products.
 - g. Stark Truss Company, Inc.
 - h. Weyerhaeuser Company.
 - i. Approved substitution.

 - 2. Laminated-Veneer Lumber Properties: As indicated on structural Drawings.

- C. Parallel-Strand Lumber: Structural composite lumber made from wood strand elements with grain primarily parallel to member lengths, evaluated and monitored according to ASTM D5456 and manufactured with an exterior-type adhesive complying with ASTM D2559.
 - 1. Manufacturers: Subject to compliance with requirements, provide products by one of the following:
 - a. LP Building Products.
 - b. Pacific Woodtech Corporation.
 - c. RedBuilt, LLC.
 - d. Weyerhaeuser Company.
 - e. Approved substitution.

 - 2. Parallel-Strand Lumber Properties: As indicated on structural Drawings.

- D. Wood I-Joists: Prefabricated units, I-shaped in cross section, made with solid or structural composite lumber flanges and wood-based structural panel webs, let into and bonded to flanges. Comply with material requirements of and with structural capacities established and monitored according to ASTM D5055.
 - 1. Manufacturers: Subject to compliance with requirements, provide products by one of the following:
 - a. Boise Cascade Corporation.
 - b. Georgia-Pacific Building Products.
 - c. LP Building Products.

**NISQUALLY STATE PARK
NEW FULL SERVICE PARK – PHASE 2**

- d. Pacific Woodtech Corporation.
 - e. RedBuilt, LLC.
 - f. Roseburg Forest Products.
 - g. Weyerhaeuser Company.
 - h. Approved substitution.
- 2. Web Material: Either oriented strand board or plywood, complying with DOC PS 2, Exposure 1, not less than those indicated.
 - 3. Wood I-Joist Properties: As indicated on structural Drawings.
 - 4. Comply with APA PRI-400. Factory mark I-joists with APA-EWS trademark indicating nominal joist depth, joist class, span ratings, mill identification, and compliance with APA-EWS standard.
- E. Rim Boards: Product designed to be used as a load-bearing member and to brace wood I-joists at bearing ends, complying with research or evaluation report for I-joists.
- 1. Manufacturer: Provide products by same manufacturer as I-joists.
 - 2. Material: All-veneer product.
 - 3. Thickness: 1-1/4 inches minimum.
 - 4. Comply with APA PRR-401, rim board grade. Factory mark rim boards with APA-EWS trademark indicating thickness, grade, and compliance with APA-EWS standard.

2.6 MISCELLANEOUS LUMBER

- A. Provide miscellaneous lumber indicated and lumber for support or attachment of other construction, including the following:
- 1. Blocking.
 - 2. Nailers.
 - 3. Furring.
- B. Dimension Lumber Items: Construction or No. 2 grade lumber of the following species:
- 1. Western woods; WCLIB or WWPA, species as indicated on structural Drawings.
- C. Concealed Boards: 15 percent maximum moisture content of the following species and grades.
- 1. Western woods, Standard or No. 3 Common grade; WCLIB or WWPA, species as indicated on structural Drawings.
- D. For blocking not used for attachment of other construction, Utility, Stud, or No. 3 grade lumber of any species may be used provided that it is cut and selected to eliminate defects that will interfere with its attachment and purpose.
- E. For blocking and nailers used for attachment of other construction, select and cut lumber to eliminate knots and other defects that will interfere with attachment of other Work.
- F. For furring strips for installing plywood or hardboard paneling, select boards with no knots capable of producing bent-over nails and damage to paneling.

**NISQUALLY STATE PARK
NEW FULL SERVICE PARK – PHASE 2**

2.7 PLYWOOD BACKING PANELS

- A. Equipment Backing Panels: Plywood, DOC PS 1, Exposure 1, C-D Plugged, fire-retardant treated, not less than 3/4 inch nominal thickness unless indicated otherwise.

2.8 METAL FRAMING ANCHORS

- A. Manufacturers: Subject to compliance with requirements, provide products by one of the following:
 - 1. Cleveland Steel Specialty Co.
 - 2. KC Metals Products, Inc.
 - 3. Phoenix Metal Products, Inc.
 - 4. Simpson Strong-Tie Co., Inc.
 - 5. USP Structural Connectors.
 - 6. Approved substitution.
- B. Allowable design loads, as published by manufacturer, shall meet or exceed those indicated or of products of manufacturers listed. Manufacturer's published values shall be determined from empirical data or by rational engineering analysis and demonstrated by comprehensive testing performed by a qualified independent testing agency. Framing anchors shall be punched for fasteners adequate to withstand same loads as framing anchors.
- C. Galvanized-Steel Sheet: Hot-dip, zinc-coated steel sheet complying with ASTM A653, G60 coating designation.
 - 1. Use for interior locations unless otherwise indicated.
- D. Hot-Dip, Heavy-Galvanized Steel Sheet: ASTM A653; structural steel (SS), high-strength low-alloy steel Type A (HSLAS Type A), or high-strength low-alloy steel Type B (HSLAS Type B); G185 coating designation; and not less than 0.034 inch thick.
 - 1. Use for wood-preservative-treated lumber and where indicated.
- E. Stainless-Steel Sheet: ASTM A666, Type 304.
 - 1. Use for exterior locations where indicated.
- F. Joist Hangers: U-shaped joist hangers with 2 inch long seat and 1-1/4 inchwide nailing flanges at least 85 percent of joist depth.
- G. I-Joist Hangers: U-shaped joist hangers as indicated on structural Drawings..
- H. Top Flange Hangers: U-shaped joist hangers as indicated on structural Drawings..
- I. Bridging: Rigid, V-section, nailless type, 0.050 inch thick, length to suit joist size and spacing.
- J. Post Bases: Adjustable-socket type for bolting in place with standoff plate to raise post as indicated on structural Drawings.

**NISQUALLY STATE PARK
NEW FULL SERVICE PARK – PHASE 2**

- K. Joist Ties: Flat straps, with holes for fasteners, for tying joists together over supports as indicated on structural Drawings.
- L. Rafter Tie-Downs: Bent strap tie for fastening rafters or roof trusses to wall studs below as indicated on structural Drawings.
- M. Rafter Tie-Downs (Hurricane or Seismic Ties): Bent strap tie for fastening rafters or roof trusses to wall studs below as indicated on structural Drawings.
- N. Floor-to-Floor Ties: Flat straps, with holes for fasteners, for tying upper floor wall studs to band joists and lower floor studs as indicated on structural Drawings.
- O. Hold-Downs: Brackets for bolting to wall studs and securing to foundation walls with anchor bolts or to other hold-downs with threaded rods and designed as indicated on structural Drawings.

2.9 FASTENERS

- A. Provide fasteners of size and type indicated, that comply with requirements specified in this Article for material and manufacture, and are acceptable to authorities having jurisdiction.
 - 1. Where rough carpentry is exposed to weather, in ground contact, pressure-preservative treated, or in area of high relative humidity, provide fasteners with hot-dip zinc coating complying with ASTM A153.
- B. Nails, Brads, and Staples: ASTM F1667.
- C. Power-Driven Fasteners: Fastener systems with an evaluation report acceptable to AHJ, based on ICC-ES AC70.
- D. Post-Installed Anchors: Fastener systems with an evaluation report acceptable to AHJ, as appropriate for substrate, based on the following:
 - 1. Mechanical Anchors:
 - a. Concrete: ICC-ES AC193.
 - 2. Adhesive Anchors:
 - a. Concrete: ICC-ES AC308.
 - 3. Materials:
 - a. Carbon-Steel Components: Zinc plated to comply with ASTM B633, Class Fe/Zn 5.
 - b. Stainless Steel with Bolts and Nuts: Comply with ASTM F593 and ASTM F594, Alloy Group 1 or 2.

**NISQUALLY STATE PARK
NEW FULL SERVICE PARK – PHASE 2**

2.10 MISCELLANEOUS MATERIALS

- A. Sill-Sealer Gaskets: Glass-fiber-resilient insulation, fabricated in strip form, for use as a sill sealer; 1 inch nominal thickness, compressible to 1/32 inch; selected from manufacturer's standard widths to suit width of sill members indicated.
- B. Sill-Sealer Gaskets: Closed-cell neoprene foam, 1/4 inch thick, selected from manufacturer's standard widths to suit width of sill members indicated.
- C. Flexible Flashing: Composite, self-adhesive, flashing product as specified in Section 076500 – Flexible Flashing.
- D. Installation Adhesives: Formulation complying with ASTM D3498 that is approved for use indicated by adhesive manufacturer.
 - 1. Application: For gluing furring and sleepers to wood or concrete.
- E. Water-Repellent Preservative: NWWDA-tested and -accepted formulation containing 3-iodo-2-propynyl butyl carbamate, combined with an insecticide containing chlorpyrifos as its active ingredient.

PART 3 - EXECUTION

3.1 INSTALLATION, GENERAL

- A. Framing Standard: Comply with AF&PA's WCD 1, "Details for Conventional Wood Frame Construction," unless otherwise indicated.
- B. Set rough carpentry to required levels and lines, with members plumb, true to line, cut, and fitted. Fit rough carpentry accurately to other construction. Locate furring, nailers, blocking, and similar supports to comply with requirements for attaching other construction.
- C. Install metal framing anchors to comply with manufacturer's written instructions. Install fasteners through each fastener hole.
- D. Install sill sealer gasket to form continuous seal between sill plates and foundation walls.
- E. Do not splice structural members between supports unless otherwise indicated.
- F. Provide blocking and framing as indicated and as required to support facing materials, fixtures, specialty items, and trim.
 - 1. Provide metal clips for fastening gypsum board at corners and intersections where framing or blocking does not provide a surface for fastening edges of panels.
 - 2. Space clips not more than 16 inches on center.
- G. Blocking for Owner-Furnished Products:

**NISQUALLY STATE PARK
NEW FULL SERVICE PARK – PHASE 2**

1. Where products are indicated as Owner-furnished/Owner-installed (OFOI) and Owner-furnished/Contractor-installed (OFCI), coordinate with Owner to obtain product information for each product to determine blocking requirements. Provide appropriate blocking for each of these products.
 2. Owner-furnished/Contractor-installed products may include the following:
 - a. Toilet and bath accessories.
 - b. Other items as indicated on Drawings.
- H. Provide fire blocking in furred spaces, stud spaces, and other concealed cavities as indicated and as follows:
1. Furred spaces of walls, at each floor level, at ceiling, and at not more than 96 inches on center with solid wood blocking or noncombustible materials accurately fitted to close furred spaces.
 2. Concealed spaces of wood-framed walls and partitions at each floor level, at ceiling line of top story, and at not more than 96 inches on center. Where fire blocking is not inherent in framing system used, provide closely fitted solid wood blocks of same width as framing members and 2 inch nominal thickness.
 3. Concealed spaces between floor sleepers with same material as sleepers to limit concealed spaces to not more than 100 sq. ft. and to solidly fill space below partitions.
 4. Concealed spaces behind combustible cornices and exterior trim at not more than 20 feet on center.
- I. Sort and select lumber so that natural characteristics do not interfere with installation or with fastening other materials to lumber. Do not use materials with defects that interfere with function of member or pieces that are too small to use with minimum number of joints or optimum joint arrangement.
- J. Comply with AWPAC M4 for applying field treatment to cut surfaces of preservative-treated lumber.
1. Use inorganic boron for items that are continuously protected from liquid water.
 2. Use copper naphthenate for items not continuously protected from liquid water.
 3. Application: Items not continuously protected from liquid water.
- K. Where wood-preservative-treated lumber is installed adjacent to metal decking, install continuous flexible flashing separator between wood and metal decking.
- L. Securely attach rough carpentry Work to substrate by anchoring and fastening as indicated, complying with the following:
1. ICC-ES evaluation report for fastener.
- M. Use steel common nails unless otherwise indicated. Select fasteners of size that will not fully penetrate members where opposite side will be exposed to view or will receive finish materials. Make tight connections between members. Install fasteners without splitting wood. Drive nails snug but do not countersink nail heads unless otherwise indicated.

**NISQUALLY STATE PARK
NEW FULL SERVICE PARK – PHASE 2**

3.2 INSTALLATION OF WOOD BLOCKING AND NAILERS

- A. Install where indicated and where required for attaching other Work. Form to shapes indicated and cut as required for true line and level of attached Work. Coordinate locations with other Work involved.
- B. Attach items to substrates to support applied loading. Recess bolts and nuts flush with surfaces unless otherwise indicated.

3.3 INSTALLATION OF WOOD FURRING

- A. Install level and plumb with closure strips at edges and openings. Shim with wood as required for tolerance of finish Work.
- B. Furring to Receive Plywood or Paneling: Install 1 by 3 inch nominal-size furring at 24 inches on center
- C. Furring to Receive Gypsum Board: Install 1 by 2 inch nominal-size furring vertically at 16 inches on center

3.4 INSTALLATION OF WALL AND PARTITION FRAMING

- A. Provide single bottom plate and double top plates using members of 2 inch nominal thickness whose widths equal that of studs, except single top plate may be used for non-load-bearing partitions. Fasten plates to supporting construction unless otherwise indicated.
 - 1. Exterior Walls: 2 by 6 inch nominal size wood studs spaced 16 inches on center unless otherwise indicated.
 - 2. Interior Partitions and Walls: 2 by 4 inch and 2 by 6 inch nominal size wood studs spaced 24 inches on center unless otherwise indicated.
- B. Construct corners and intersections with 3 or more studs, except that 2 studs may be used for interior non-load-bearing partitions.
- C. Frame openings with multiple studs and headers. Provide nailed header members of thickness equal to width of studs. Support headers on jamb studs.
 - 1. For non-load-bearing partitions, provide double-jamb studs and headers not less than 4 inch nominal depth for openings 48 inches and less in width, 6 inch nominal depth for openings 48 to 72 inches in width, 8 inch nominal depth for openings 72 to 120 inches in width, and not less than 10 inch nominal depth for openings 10 to 12 feet in width.
 - 2. For load-bearing walls, provide double-jamb studs for openings 60 inches and less in width, and triple-jamb studs for wider openings unless indicated otherwise. Provide headers of depth indicated.

**NISQUALLY STATE PARK
NEW FULL SERVICE PARK – PHASE 2**

3.5 INSTALLATION OF FLOOR JOIST FRAMING

- A. Install floor joists with crown edge up and support ends of each member with not less than 1-1/2 inches of bearing on wood or metal, or 3 inches on masonry. Attach floor joists as follows:
 - 1. Where supported on wood members, by toe nailing or by using metal framing anchors.
 - 2. Where framed into wood supporting members, by using wood ledgers as indicated or, if not indicated, by using metal joist hangers.
- B. Fire Cuts: At joists built into masonry, bevel cut ends 3 inches and do not embed more than 4 inches.
- C. Frame openings with headers and trimmers supported by metal joist hangers; double headers and trimmers where span of header exceeds 48 inches.
- D. Do not notch in middle third of joists; limit notches to 1/6 depth of joist, 1/3 at ends. Do not bore holes larger than 1/3 depth of joist; do not locate closer than 2 inches from top or bottom.
- E. Provide solid blocking of 2 inch nominal thickness by depth of joist at ends of joists unless nailed to header or band.
- F. Lap members framing from opposite sides of beams, girders, or partitions not less than 4 inches or securely tie opposing members together. Provide solid blocking of 2 inch nominal thickness by depth of joist over supports.
- G. Anchor members paralleling masonry with 1/4 by 1-1/4 inch metal strap anchors spaced not more than 96 inches on center., extending over and fastening to 3 joists. Embed anchors at least 4 inches into grouted masonry with ends bent at right angles and extending 4 inches beyond bend.
- H. Provide solid blocking between joists under jamb studs for openings.
- I. Under non-load-bearing partitions, provide double joists separated by solid blocking equal to depth of studs above.
 - 1. Provide triple joists separated as above, under partitions receiving ceramic tile and similar heavy finishes or fixtures.
- J. Provide bridging of type indicated below, at intervals of 96 inches on center between joists.
 - 1. Diagonal wood bridging formed from bevel-cut, 1 by 3 inch nominal-size lumber, double-crossed and nailed at both ends to joists.
 - 2. Steel bridging installed to comply with bridging manufacturer's written instructions.

3.6 INSTALLATION OF CEILING JOIST AND RAFTER FRAMING

- A. Ceiling Joists: Install with crown edge up and complying with requirements specified above for floor joists. Face nail to ends of parallel rafters.
 - 1. Delete subparagraph below if not applicable. This condition requires subflooring or stringers, as specified, to provide cross-tie.

**NISQUALLY STATE PARK
NEW FULL SERVICE PARK – PHASE 2**

2. Where ceiling joists are at right angles to rafters, provide additional short joists parallel to rafters from wall plate to first joist; nail to ends of rafters and to top plate, and nail to first joist or anchor with framing anchors or metal straps. Provide 1 by 8 inch nominal-size or 2 by 4 inch nominal-size stringers spaced 48 inches on center crosswise over main ceiling joists.
- B. Rafters: Notch to fit exterior wall plates and use metal framing anchors. Double rafters to form headers and trimmers at openings in roof framing, if any, and support with metal hangers. Where rafters abut at ridge, place directly opposite each other and nail to ridge member or use metal ridge hangers.
1. At valleys, provide double-valley rafters of size indicated or, if not indicated, of same thickness as regular rafters and 2 inches deeper. Bevel ends of jack rafters for full bearing against valley rafters.
 2. At hips, provide hip rafter of size indicated or, if not indicated, of same thickness as regular rafters and 2 inches deeper. Bevel ends of jack rafters for full bearing against hip rafter.
- C. Provide collar beams (ties) as indicated or, if not indicated, provide 1 by 6 inch nominal-size boards between every third pair of rafters, but not more than 48 inches on center. Locate below ridge member, at third point of rafter span. Cut ends to fit roof slope and nail to rafters.
- D. Provide special framing as indicated for eaves, overhangs, dormers, and similar conditions if any.

3.7 INSTALLATION OF PLYWOOD BACKING PANELS

- A. Install plywood backing panels by fastening to studs.
1. Coordinate locations with utilities requiring backing panels.
 2. Install fire-retardant-treated plywood backing panels with classification marking of testing agency exposed to view.

3.8 PROTECTION

- A. Protect wood that has been treated with inorganic boron (SBX) from weather.
1. If, despite protection, inorganic boron-treated wood becomes wet, apply EPA-registered borate treatment.
 2. Apply borate solution by spraying to comply with EPA-registered label.
- B. Protect rough carpentry from weather.
1. If, despite protection, wood that becomes wet enough that moisture content exceeds that specified, apply EPA-registered borate treatment.
 2. Apply borate solution by spraying to comply with EPA-registered label.

END OF SECTION

**NISQUALLY STATE PARK
NEW FULL SERVICE PARK – PHASE 2**

SECTION 061316 – POLE CONSTRUCTION

PART 1 - GENERAL

1.1 SUMMARY

A. Section Includes:

1. Round, peeled wood poles for the Administrative Building, Kiosks, and Boardwalk Threshold Pole.
2. Pole connectors.

1.2 DEFINITIONS

A. Poles: Round wood members, called either "poles" or "posts" in the referenced standards.

B. Inspection agencies, and the abbreviations used to reference them, include the following:

1. LHC: Log Home Council, National Association of Home Builders.
2. TP: Timber Products Inspections, Inc.

1.3 ADMINISTRATIVE REQUIREMENTS

A. Preinstallation Meeting: Conduct meeting at Project.

1.4 ACTION SUBMITTALS

A. Product Data: For preservative-treated wood products and timber connectors.

1. Include data for wood-preservative treatment from chemical-treatment manufacturer and certification by treating plant that treated materials comply with requirements.
 - a. Indicate type of preservative used and net amount of preservative retained.
 - b. Include chemical-treatment manufacturer's written instructions for finishing treated material.
2. For timber connectors, include installation instructions.
3. Manufacturer's specifications, installation instructions, and recommendations for types of products required.

B. Shop Drawings:

1. Show pertinent details of poles and their interface with other components of structure. Include manufacturer's recommended installation procedures and other supporting data required.

**NISQUALLY STATE PARK
NEW FULL SERVICE PARK – PHASE 2**

1.5 INFORMATIONAL SUBMITTALS

A. Material Certificates:

1. For poles specified to comply with minimum allowable unit stresses, indicate species and grade selected for each use and design values approved by ALSC's Board of Review.

B. Certificates of Inspection: Issued by lumber-grading agency for poles not marked with grade stamp.

1.6 DELIVERY, STORAGE, AND HANDLING

A. Schedule delivery of materials to avoid extended on-site storage and to avoid delaying Work.

B. Store materials protected from weather and contact with damp or wet surfaces.

C. After poles are sealed, store poles off ground, laid level with air space between each member and left uncovered to promote drying.

1. Avoid marring or otherwise damaging poles.
2. Avoid undue racking or undue distortion of poles when handling.

PART 2 - PRODUCTS

2.1 WOOD POLES

A. Select poles that comply with ICC 400.

B. Select poles for uniformity and appearance. Poles with sweeps, reverse bends, short crooks, hook butts, or ground swell will not be acceptable.

C. Wood Poles Members:

1. Species: Douglas fir-larch, No. 1 or No. 2 Sawn or Unseen Round Timber Beams, LHC, or TP or as indicated on structural Drawings.
2. Surface: Peeled and turned.
3. Size: Uniform diameters and lengths as indicated on Drawings.
4. Finish: Clear.
5. Color: None.

D. Seasoning Checks: Seasoning checks are not considered defects. The following pertains to fully cured poles:

1. Width of Checks: Maximum 1/8 inch.
2. Length of Checks: No maximum.

E. Tolerances: Maximum of 1/8 inch in 10 feet along straight line from end to end of pole member.

F. Poles fabricated from old growth timber is not permitted.

**NISQUALLY STATE PARK
NEW FULL SERVICE PARK – PHASE 2**

2.2 PRESERVATIVE-TREATED WOOD MATERIALS

- A. Brush-applied, acrylic-based wood preservative treatment.
 - 1. Product: Subject to compliance with requirements, provide the following:
 - a. Rust-Oleum Corporation: Woodlife Classic Clear Wood Preservative.
 - b. Approved substitutions.
 - 2. VOC Content: Maximum 250 g/L.
- B. After treatment, redry materials to 19 percent maximum moisture content.
- C. Mark treated materials with treatment quality mark of an inspection agency approved by ALSC's Board of Review.
 - 1. For exposed items indicated to receive stained or natural finish, omit marking and provide certificates of treatment compliance issued by inspection agency if acceptable to AHJ.
- D. Application: Treat poles unless indicated otherwise.

2.3 POLE CONNECTORS

- A. Manufacturers: Subject to compliance with requirements, provide products by one of the following:
 - 1. Cleveland Steel Specialty Co.
 - 2. Simpson Strong-Tie Co., Inc.
 - 3. USP Structural Connectors.
 - 4. Approved substitution.
- B. Fabricate structural steel connection components as indicated on structural Drawings.
- C. Materials: Unless otherwise indicated, fabricate from the following materials:
 - 1. Structural-steel shapes, plates, and flat bars complying with ASTM A36.
 - 2. Round steel bars complying with ASTM A575, Grade M 1020.
 - 3. Hot-rolled steel sheet complying with ASTM A1011, Structural Steel, Type SS, Grade 33.
 - 4. Stainless steel plate, sheet, and strip complying with ASTM 240 or ASTM A666, Type 304.
 - 5. Stainless steel flat bars complying with ASTM A666, Type 304.
 - 6. Stainless steel bars and shapes complying with ASTM A276, Type 304.
- D. Finish steel connection components and fasteners with high performance coating as specified in Section 099600 – High-Performance Coatings.

**NISQUALLY STATE PARK
NEW FULL SERVICE PARK – PHASE 2**

2.4 FABRICATION

- A. Shop or field fabricate poles to dimensions indicated to comply with the following:
1. Remove bark by turning.
 2. Limit spiral grain twists to one complete turn in any 30 feet of length or portion thereof.
 3. Cut butts and tips as indicated.
 4. Cut and fit members accurately to length to achieve tight joint fit.
 5. Mill pole to accept saddles, split rings, and shear plate connections, and predrill holes for bolted connections, fasteners, and assembly of units.
 - a. Coordinate with connectors and hardware for locations of cuts, mortises, and holes.
 6. Upon completion of milling and drilling, seal with wood preservative as specified below.
- B. Preservative Treatment Seal Coat:
1. After fabricating and surfacing each pole unit, apply a saturation coat of preservative treatment material on surfaces of each unit except for treated wood where treatment included a water repellent.
 2. Follow preservative treatment manufacturer's written instructions.
 3. Complete cutting and boring of poles prior to application of preservative treatment.
 4. Ensure surfaces of poles are clean, dry, and free of contaminants.
 5. Do not apply preservative treatment material when temperature is 40 degs F or below.
 6. Brush-apply preservative treatment material in 2 coats, avoiding overlapping of brush strokes.
 7. Do not apply thick coats or allow material to puddle.
 8. Wipe off excess material remaining after 5 minutes from application.
 9. Allow 24 hours of drying time between applications.
 10. Allow units to cure and air dry, protected from the elements, for not less than 14 days.

PART 3 - EXECUTION

3.1 EXAMINATION

- A. Examine footings, with Installer present, for compliance with requirements for installation tolerances and other conditions affecting performance of Work.
- B. Proceed with installation only after unsatisfactory conditions have been corrected.

3.2 INSTALLATION

- A. Erect poles true and plumb. Provide temporary bracing to maintain lines and levels until permanent supporting members are in place.
1. Handle and temporarily support poles to prevent surface damage, compression, and other effects that might interfere with indicated finish.

**NISQUALLY STATE PARK
NEW FULL SERVICE PARK – PHASE 2**

- B. Cutting: Avoid extra cutting after fabrication. Where field fitting is unavoidable, comply with requirements for shop fabrication.
- C. Fitting: Fit members by cutting and restoring exposed surfaces to match specified surfacing.
 - 1. Where preservative-treated members must be cut during erection, apply a field-treatment preservative to cut locations.
- D. Install pole connectors as indicated.
 - 1. Unless otherwise indicated, install bolts with same orientation within each connection and in similar connections.
 - 2. Install bolts with orientation as indicated or, if not indicated, as directed by Architect.

3.3 REPAIR

- A. Repair damaged surfaces after completing erection. Replace damaged poles if repairs are not approved by Architect.

END OF SECTION

**NISQUALLY STATE PARK
NEW FULL SERVICE PARK – PHASE 2**

SECTION 061600 – SHEATHING

PART 1 - GENERAL

1.1 SUMMARY

A. Section Includes:

1. Wall sheathing.
2. Roof sheathing.
3. Roof cover boards.
4. Sheathing joint-and-penetration treatment materials.

1.2 ADMINISTRATIVE REQUIREMENTS

A. Preinstallation Meeting: Conduct meeting at Project site.

1. Review the following:
 - a. Special details.
 - b. Transitions.
 - c. Mockups.
 - d. Air-leakage testing.
 - e. Protection.

1.3 ACTION SUBMITTALS

A. Product Data: For each type of process and factory-fabricated product. Indicate component materials and dimensions and include construction and application details.

1. Include data for fire-retardant treatment from chemical treatment manufacturer and certification by treating plant that treated plywood complies with requirements. Include physical properties of treated materials.
2. For fire-retardant treatments, include physical properties of treated plywood both before and after exposure to elevated temperatures, based on testing by a qualified independent testing agency in accordance with ASTM D5516.

1.4 INFORMATIONAL SUBMITTALS

A. Evaluation Reports: For the following, from ICC-ES:

1. Fire-retardant-treated plywood.

**NISQUALLY STATE PARK
NEW FULL SERVICE PARK – PHASE 2**

1.5 DELIVERY, STORAGE, AND HANDLING

- A. Deliver materials in original, unopened packaging and store in an enclosed shelter providing protection from damage and exposure to the elements.
 - 1. Store within temperature limits required by manufacturer.
 - 2. Store air- and water-resistive sheathing board supported on risers on a flat platform.
 - 3. Comply with manufacturer's written instructions for safety and handling.
- B. Store accessory materials in a location with constant ambient temperatures of 40 to 80 deg F.
- C. Stack panels flat with spacers beneath and between each bundle to provide air circulation. Protect sheathing from weather by covering with waterproof sheeting, securely anchored. Provide for air circulation around stacks and under coverings.

PART 2 - PRODUCTS

2.1 PERFORMANCE CRITERIA

- A. Fire-Resistance Ratings: As tested per ASTM E119; testing by a qualified testing agency. Identify products with appropriate markings of applicable testing agency.
 - 1. Fire-Resistance Ratings: Indicated by design designations from UL's "Fire Resistance Directory" or from listings of another qualified testing agency.

2.2 WOOD PANEL PRODUCTS

- A. Thickness: As needed to comply with requirements specified, but not less than thickness indicated.
- B. Factory mark panels to indicate compliance with applicable standard.

2.3 FIRE-RETARDANT-TREATED PLYWOOD

- A. Where fire-retardant-treated materials are indicated, use materials complying with requirements in this Article that are acceptable to authorities having jurisdiction and with fire-test-response characteristics specified as determined by testing identical products per test method indicated by a qualified testing agency.
- B. Fire-Retardant-Treated Plywood by Pressure Process: Products with a flame-spread index of 25 or less when tested according to ASTM E84, and with no evidence of significant progressive combustion when test is extended an additional 20 minutes, and with flame front not extending more than 10.5 feet beyond centerline of burners at any time during test.
 - 1. Use treatment that does not promote corrosion of metal fasteners.
 - 2. Interior Type A: Treated materials shall have a moisture content of 28 percent or less when tested according to ASTM D3201 at 92 percent relative humidity. Use where exterior type is not indicated.

**NISQUALLY STATE PARK
NEW FULL SERVICE PARK – PHASE 2**

3. Design Value Adjustment Factors: Treated lumber plywood shall be tested according to ASTM D5516, and design value adjustment factors shall be calculated according to ASTM D6305. Span ratings after treatment shall be not less than span ratings specified.
- C. Kiln-dry material after treatment to a maximum moisture content of 15 percent. Do not use material that is warped or does not comply with requirements for untreated material.
- D. Identify fire-retardant-treated plywood with appropriate classification marking of qualified testing agency.
- E. Application: Treat plywood indicated on Drawings.

2.4 WALL SHEATHING

- A. Glass-Mat Fiber-Reinforced Gypsum Sheathing: ASTM C1177, with fiberglass mat laminated to both sides and with manufacturer's standard edges.
 1. Products: Subject to compliance with requirements, provide one of the following:
 - a. CertainTeed Corporation: GlasRoc Type X.
 - b. Georgia-Pacific Gypsum LLC: DensGlass Fireguard Sheathing.
 - c. National Gypsum Company: Gold Bond eXP Fire-Shield Interior Extreme Gypsum Panel.
 - d. USG Corporation: Securock Glass-Mat Sheathing Firecode X.
 - e. Approved substitution.
 2. Type and Thickness: Regular, Type X, 5/8 inch thick.
 3. Size: 48 inches by longest practical length for vertical installation.
 4. Maximum Framing Spacing: 16 inches on center.
 5. Application:

2.5 ROOF SHEATHING

- A. Plywood Roof Sheathing: DOC PS 2, Exposure 1 or Exterior sheathing.
 1. Span Rating: As indicated on structural Drawings.
 2. Performance Category: As indicated on structural Drawings.
- B. Oriented-Strand-Board Sheathing (OSB): DOC PS 2, Exposure 1 or Exterior sheathing.
 1. Span Rating: Not less than 24/16.
 2. Nominal Thickness: As indicated on structural Drawings.

2.6 ROOF COVER BOARDS

- A. Cover Boards: ASTM C1177, unprimed, glass-mat-faced, water-resistant gypsum substrate.
 1. Products: Subject to compliance with requirements, provide one of the following:

**NISQUALLY STATE PARK
NEW FULL SERVICE PARK – PHASE 2**

- a. Georgia-Pacific Gypsum LLC: DensDeck Roof Boards.
 - b. National Gypsum Company: DEXcell Glass Mat Roof Board.
 - c. United States Gypsum Company: Securock Glass-Mat Roof Board.
 - d. Thickness: 1/2 inch.
- B. Fasteners: Factory-coated steel fasteners and metal or plastic plates complying with corrosion-resistance, designed for fastening substrate board to roof deck.

2.7 FASTENERS

- A. Provide fasteners of size and type indicated that comply with requirements specified in this Article for material and manufacture.
- 1. Provide screws with hot-dip zinc coating complying with ASTM A153 or other corrosion-protective coating having a salt-spray resistance of more than 800 hours according to ASTM B117.
- B. Power-Driven Fasteners: Fastener systems with an evaluation report acceptable to authorities having jurisdiction, based on ICC-ES AC70.
- C. Screws for Fastening Sheathing to Framing: For gypsum and wood panel sheathing, comply with the following:
- 1. Wood Framing and Cold-Formed Metal Framing: ASTM C1002.
 - a. For cold-formed metal framing less than 0.033 inch thick.

2.8 SHEATHING JOINT-AND-PENETRATION TREATMENT MATERIALS

- A. Sealant for Glass-Mat Gypsum Sheathing: Silicone emulsion sealant complying with ASTM C834, compatible with sheathing tape and sheathing and recommended by tape and sheathing manufacturers for use with glass-fiber sheathing tape and for covering exposed fasteners.
- 1. Sheathing Tape: Self-adhering glass-fiber tape, minimum 2 inches wide, 10 by 10 or 10 by 20 threads per inch, of type recommended by sheathing and tape manufacturers for use with silicone emulsion sealant in sealing joints in glass-mat gypsum sheathing and with a history of successful in-service use.
- B. Joint Compound for Exterior Applications:
- 1. Glass-Mat Gypsum Sheathing Board: As recommended by manufacturer.

**NISQUALLY STATE PARK
NEW FULL SERVICE PARK – PHASE 2**

PART 3 - EXECUTION

3.1 INSTALLATION, GENERAL

- A. Do not use materials with defects that impair quality of sheathing or pieces that are too small to use with minimum number of joints or optimum joint arrangement. Arrange joints so that pieces do not span between fewer than 3 support members.
- B. Cut panels at penetrations, edges, and other obstructions of Work; fit tightly against abutting construction unless otherwise indicated.
- C. Coordinate sheathing installation with flashing and joint-sealant installation so these materials are installed in sequence and manner that prevent exterior moisture from passing through completed assembly.
- D. Do not bridge building expansion joints; cut and space edges of panels to match spacing of structural support elements.
- E. Coordinate sheathing installation with installation of materials installed over sheathing so sheathing is not exposed to precipitation or left exposed at end of workday when rain is forecast.

3.2 INSTALLATION OF GYPSUM SHEATHING

- A. Comply with GA-253 and with manufacturer's written instructions.
 - 1. Fasten gypsum sheathing to framing with screws.
 - 2. Install boards with a 3/8 inch gap where non-load-bearing construction abuts structural elements.
 - 3. Install boards with a 1/4 inch gap where they abut concrete or similar materials that might retain moisture, to prevent wicking.
- B. Apply fasteners so heads bear tightly against face of sheathing, but do not cut into facing.
- C. Horizontal Installation: Install sheathing with V-grooved edge down and tongue edge up. Interlock tongue with groove to bring long edges in contact with edges of adjacent boards without forcing. Abut ends of boards over centers of studs, and stagger end joints of adjacent boards not less than 1 stud spacing. Attach boards at perimeter and within field of board to each steel stud.
 - 1. Space fasteners approximately 8 inches on center and set back a minimum of 3/8 inch from edges and ends of boards.
- D. Seal sheathing joints according to sheathing manufacturer's written instructions.
 - 1. Apply glass-fiber sheathing tape to glass-mat gypsum sheathing joints and apply and trowel sealant to embed entire face of tape in sealant. Apply sealant to exposed fasteners with a trowel so fasteners are completely covered. Seal other penetrations and openings.

**NISQUALLY STATE PARK
NEW FULL SERVICE PARK – PHASE 2**

3.3 INSTALLATION OF WOOD STRUCTURAL PANEL

- A. Comply with applicable recommendations in APA Form No. E30, "Engineered Wood Construction Guide," for types of structural-use panels and applications indicated.
- B. Fastening Methods: Fasten panels as indicated below:
 - 1. Wall and Roof Sheathing:
 - a. Apply a continuous bead of glue to framing members at edges of wall sheathing panels.
 - b. Screw or nail to framing.
 - c. Space panels 1/8 inch apart at edges and ends.

3.4 PROTECTION

- A. Gypsum Sheathing:
 - 1. Protect sheathing by covering exposed exterior surface of sheathing with weather-resistant sheathing paper securely fastened to framing.
 - 2. Apply covering immediately after sheathing is installed.

END OF SECTION

**NISQUALLY STATE PARK
NEW FULL SERVICE PARK – PHASE 2**

SECTION 061753 – SHOP-FABRICATED WOOD TRUSSES

PART 1 - GENERAL

1.1 SUMMARY

A. Section Includes:

1. Wood roof trusses.
2. Wood girder trusses.

1.2 ACTION SUBMITTALS

A. Product Data: For metal-plate connectors, metal truss accessories, and fasteners.

1. For products receiving a waterborne treatment, include statement that moisture content of treated materials was reduced to levels specified before shipment to truss fabricator.

B. Shop Drawings: Show fabrication and installation details for trusses.

1. Show location, pitch, span, camber, configuration, and spacing for each type of truss required.
2. Indicate sizes, stress grades, and species of lumber.
3. Indicate locations of permanent bracing required to prevent buckling of individual truss members due to design loads.
4. Indicate locations, sizes, and materials for permanent bracing required to prevent buckling of individual truss members due to design loads.
5. Indicate type, size, material, finish, design values, orientation, and location of metal connector plates.
6. Show splice details and bearing details.
7. Submit Shop Drawings that have been engineered and certified by professional engineer licensed in the State in which Project is located.

- a. Include seal and signature of professional engineer on Shop Drawings.

C. Delegated-Design Submittal: For metal-plate-connected wood trusses, indicating compliance with performance and design criteria.

1. Include analysis data signed and sealed by qualified professional engineer responsible for their preparation.

1.3 INFORMATIONAL SUBMITTALS

A. Qualification Data:

1. For metal connector-plate manufacturer.
2. For fabricator.

**NISQUALLY STATE PARK
NEW FULL SERVICE PARK – PHASE 2**

3. For professional engineer indicating experience with providing delegated-design engineering services of the kind indicated.
 - a. Include documentation that engineer is licensed in state in which Project is located.
- B. Material Certificates: For dimension lumber specified to comply with minimum specific gravity. Indicate species and grade selected for each use and specific gravity.
- C. Product Certificates: For metal-plate-connected wood trusses, signed by officer of truss-fabricating firm.
- D. Evaluation Reports: For the following, from ICC-ES:
 1. Metal-plate connectors.
 2. Metal truss accessories.

1.4 QUALITY ASSURANCE

- A. Metal Connector-Plate Manufacturer Qualifications: A manufacturer that is a member of TPI and that complies with quality-control procedures in TPI 1 for manufacture of connector plates.
 1. Manufacturer's responsibilities include providing professional engineering services needed to assume engineering responsibility.
 2. Engineering Responsibility: Preparation of Shop Drawings and comprehensive engineering analysis by a qualified professional engineer.
- B. Fabricator Qualifications: Shop that participates in a recognized quality-assurance program, complies with quality-control procedures in TPI 1, and involves third-party inspection by an independent testing and inspecting agency acceptable to Architect and authorities having jurisdiction.
- C. Delegated-Design Engineer Qualifications: Professional engineer experienced in providing delegated-design engineering services of the kind indicated and is legally qualified to practice in state where Project is located.

1.5 DELIVERY, STORAGE, AND HANDLING

- A. Handle and store trusses to comply with recommendations in SBCA BCSI, "Building Component Safety Information: Guide to Good Practice for Handling, Installing, Restraining, & Bracing Metal Plate Connected Wood Trusses."
 1. Store trusses flat, off of ground, and adequately supported to prevent lateral bending.
 2. Protect trusses from weather by covering with waterproof sheeting, securely anchored.
 3. Provide for air circulation around stacks and under coverings.
- B. Inspect trusses showing discoloration, corrosion, or other evidence of deterioration. Discard and replace trusses that are damaged or defective.

**NISQUALLY STATE PARK
NEW FULL SERVICE PARK – PHASE 2**

PART 2 - PRODUCTS

2.1 PERFORMANCE CRITERIA

- A. Delegated-Design: Engage a qualified professional engineer to design metal-plate-connected wood trusses, including attachment to building construction.
- B. Structural Performance: Metal-plate-connected wood trusses shall be capable of withstanding design loads within limits and under conditions indicated. Comply with requirements in TPI 1 unless more stringent requirements are specified below.
 - 1. Design Loads: As indicated on structural Drawings.
 - 2. Maximum Deflection under Design Loads:
 - a. Live Load: L/360.
 - b. Total Load: L.240.
- C. Comply with applicable requirements and recommendations of TPI 1, TPI DSB, and SBCA BCSI.
- D. Wood Structural Design Standard: Comply with applicable requirements in AF&PA's "National Design Specifications for Wood Construction" and its "Supplement."
- E. Seismic Performance: Shop-fabricated wood trusses and connectors shall withstand effects of earthquake motions determined according to ASCE 7.

2.2 WOOD PRODUCTS

- A. Lumber: Comply with DOC PS 20 and with applicable rules of any rules-writing agency certified by ALSC Board of Review.
 - 1. Provide lumber graded by an agency certified by ALSC Board of Review to inspect and grade lumber under the rules indicated.
 - 2. Factory mark each piece of lumber with grade stamp of grading agency.
 - 3. Provide dressed lumber, S4S.
 - 4. Provide dry lumber with 15 percent maximum moisture content at time of dressing.
- B. Minimum Chord Size for Roof Trusses: 2 by 4 inches nominal for both top and bottom chords, unless indicated otherwise.
- C. Minimum Specific Gravity for Top Chords: 0.50.
- D. Permanent Bracing: Provide wood bracing that complies with requirements for miscellaneous lumber as indicated on structural Drawings.

**NISQUALLY STATE PARK
NEW FULL SERVICE PARK – PHASE 2**

2.3 METAL CONNECTOR PLATES

- A. Manufacturers: Subject to compliance with requirements, provide products by one of the following:
 - 1. Alpine Engineered Products, Inc.; a division of ITW Building Components Group, Inc.
 - 2. Cherokee Metal Products, Inc.; Masengill Machinery Company.
 - 3. CompuTrus, Inc.
 - 4. Eagle Metal Products.
 - 5. Jager Building Systems, Inc.
 - 6. MiTek Industries, Inc.
 - 7. Robbins Engineering, Inc.
 - 8. Truswal Systems Corporation.
- B. Fabricate connector plates to comply with TPI 1.
- C. Hot-Dip Galvanized-Steel Sheet: ASTM A 653; Structural Steel (SS), high-strength low-alloy steel Type A (HSLAS Type A), or high-strength low-alloy steel Type B (HSLAS Type B); G60 coating designation; and not less than 0.036 inch thick.
 - 1. Use for interior locations unless otherwise indicated.
- D. Stainless-Steel Sheet: ASTM A 666, Type 304, and not less than 0.035 inch thick.
 - 1. Use for exterior locations and where indicated.

2.4 FASTENERS

- A. Provide fasteners of size and type indicated that comply with requirements specified in this article for material and manufacture.
 - 1. Provide fasteners for use with metal framing anchors that comply with written recommendations of metal framing manufacturer.
- B. Nails, Brads, and Staples: ASTM F 1667.
- C. Power-Driven Fasteners: NES NER-272.
- D. Wood Screws: ASME B18.6.1.
- E. Lag Bolts: ASME B18.2.1.
- F. Bolts: Steel bolts complying with General Structural Notes with ASTM A563 hex nuts and, where indicated, flat washers.
- G. Expansion Anchors: See General Structural Notes.

**NISQUALLY STATE PARK
NEW FULL SERVICE PARK – PHASE 2**

2.5 METAL FRAMING ANCHORS AND ACCESSORIES

- A. Manufacturers: Subject to compliance with requirements, provide products by one of the following:
1. Cleveland Steel Specialty Co.
 2. KC Metals Products, Inc.
 3. Phoenix Metal Products, Inc.
 4. Simpson Strong-Tie Co., Inc.
 5. USP Structural Connectors.
- B. Allowable design loads, as published by manufacturer, shall comply with or exceed those indicated. Manufacturer's published values shall be determined from empirical data or by rational engineering analysis and demonstrated by comprehensive testing performed by a qualified independent testing agency. Framing anchors shall be punched for fasteners adequate to withstand same loads as framing anchors.
- C. Galvanized-Steel Sheet: Hot-dip, zinc-coated steel sheet complying with ASTM A 653, G60 coating designation.
1. Use for interior locations unless otherwise indicated.
- D. Truss Tie-Downs: Bent strap tie for fastening roof trusses to wall studs below.
1. Size: 1-1/2 inches wide by 0.050 inch thick.
- E. Truss Tie-Downs (Seismic Ties): Bent strap tie for fastening roof trusses to wall studs below. Tie fits over top of truss and fastens to both sides of truss, top plates, and one side of stud below.
1. Size: 2-1/4 inches wide by 0.062 inch thick.
- F. Truss Tie-Downs (Seismic Ties): Bent strap tie for fastening roof trusses to wall studs below. Tie fits over top of truss and fastens to both sides of truss, inside face of top plates, and both sides of stud below.
1. Size: 2-1/2 inches wide by 0.062 inch thick.
- G. Roof Truss Clips: Angle clips for bracing bottom chord of roof trusses at non-load-bearing walls. Clip is fastened to truss through slotted holes to allow for truss deflection.
1. Size: 1-1/4 inches wide by 0.050 inch thick.
- H. Roof Truss Bracing/Spacers: U-shaped channels made to fit between 2 adjacent trusses and accurately space them apart, and with tabs having metal teeth for fastening to trusses.
1. Size: 1-1/2 inches wide by 1 inch deep by 0.040 inch thick.
- I. Drag Strut Connectors: Angle clip with one leg extended for fastening to side of girder truss.
1. Angle Clips: 3 by 3 by 0.179 by 8 inches with extended leg 8 inches long. Connector has galvanized finish.
 2. Angle Clips: 3 by 3 by 0.239 by 10-1/2 inches with extended leg 10-1/2 inches long. Connector has painted finish.

**NISQUALLY STATE PARK
NEW FULL SERVICE PARK – PHASE 2**

- J. Provide fasteners of size and type indicated that comply with requirements specified in this Article for material and manufacture.

2.6 MISCELLANEOUS MATERIALS

- A. Galvanizing Repair Coating: Zinc-rich, cold galvanizing compound as specified in Section 055000 – Metal Fabrications.

2.7 FABRICATION

- A. Cut truss members to accurate lengths, angles, and sizes to produce close-fitting joints.
- B. Fabricate metal connector plates to sizes, configurations, thicknesses, and anchorage details required to withstand design loads for types of joint designs indicated.
- C. Assemble truss members in design configuration indicated; use jigs or other means to ensure uniformity and accuracy of assembly, with joints closely fitted to comply with tolerances in TPI 1. Position members to produce design camber indicated.
 - 1. Fabricate wood trusses within manufacturing tolerances in TPI 1.
- D. Connect truss members by metal connector plates located and securely embedded simultaneously in both sides of wood members by air or hydraulic press.

2.8 SOURCE QUALITY CONTROL

- A. Special Inspections: Owner will engage a qualified special inspector to perform special inspections.
 - 1. Provide special inspector with access to fabricator's documentation of detailed fabrication and quality-control procedures that provide a basis for inspection control of the workmanship and the fabricator's ability to conform to approved construction documents and referenced standards.
 - 2. Provide special inspector with access to places where wood trusses are being fabricated to perform inspections.
- B. Correct deficiencies in Work that special inspections indicate do not comply with Contract Documents.

PART 3 - EXECUTION

3.1 INSTALLATION

- A. Install wood trusses only after supporting construction is in place and is braced and secured.
- B. If trusses are delivered to Project site in more than one piece, assemble trusses before installing.

**NISQUALLY STATE PARK
NEW FULL SERVICE PARK – PHASE 2**

- C. Hoist trusses in place by lifting equipment suited to sizes and types of trusses required, exercising care not to damage truss members or joints by out-of-plane bending or other causes.
- D. Install and brace trusses according to TPI recommendations and as indicated.
- E. Install trusses plumb, square, and true to line and securely fasten to supporting construction.
- F. Space trusses as indicated on structural Drawings. Adjust and align trusses in location before permanently fastening.
- G. Anchor trusses securely at bearing points; use metal truss tie-downs as applicable. Install fasteners through each fastener hole in metal framing anchors according to manufacturer's fastening schedules and written instructions.
- H. Securely connect each truss ply required for forming built-up girder trusses.
 - 1. Anchor trusses to girder trusses as indicated.
- I. Install and fasten permanent bracing during truss erection and before construction loads are applied. Anchor ends of permanent bracing where terminating at walls or beams.
 - 1. Install bracing to comply with in Section 061000 – Rough Carpentry.
- J. Install wood trusses within installation tolerances in TPI 1.
- K. Do not alter trusses in field. Do not cut, drill, notch, or remove truss members.
- L. Replace wood trusses that are damaged or do not comply with requirements.
 - 1. Damaged trusses may be repaired according to truss repair details signed and sealed by qualified professional engineer responsible for truss design, when approved by Architect.

3.2 REPAIR

- A. Repair damaged galvanized coatings on exposed surfaces according to ASTM A780 and manufacturer's written instructions.

3.3 PROTECTION

- A. Protect wood that has been treated with inorganic boron (SBX) from weather. If, despite protection, inorganic boron-treated wood becomes wet, apply EPA-registered borate treatment. Apply borate solution by spraying to comply with EPA-registered label.
- B. Protect wood trusses from weather. If, despite protection, wood trusses become wet, apply EPA-registered borate treatment. Apply borate solution by spraying to comply with EPA-registered label.

**NISQUALLY STATE PARK
NEW FULL SERVICE PARK – PHASE 2**

3.4 FIELD QUALITY CONTROL

- A. Special Inspections: Owner will engage a qualified special inspector to perform special inspections to verify that temporary installation restraint/bracing and permanent individual truss member restraint/bracing are installed in accordance with approved truss submittal package.

END OF SECTION

**NISQUALLY STATE PARK
NEW FULL SERVICE PARK – PHASE 2**

SECTION 061800 – GLUED-LAMINATED CONSTRUCTION

PART 1 - GENERAL

1.1 SUMMARY

- A. Section includes:
1. Framing using structural glued-laminated timber.

1.2 DEFINITIONS

- A. Structural Glued-Laminated (Glulam) Timber: An engineered, stress-rated timber product assembled from selected and prepared wood laminations bonded together with adhesives and with grain of laminations approximately parallel longitudinally.

1.3 ACTION SUBMITTALS

- A. Product Data: For each type of product.
1. Include data on lumber, adhesives, fabrication, and protection.
 2. For connectors. Include installation instructions.
- B. Shop Drawings:
1. Show layout of structural glued-laminated timber system and full dimensions of each member.
 2. Indicate species and laminating combination.
 3. Include large-scale details of connections.
 4. Include seismic design calculations.
 5. Submit Shop Drawings that have been engineered and certified by professional engineer licensed in the State in which Project is located.
 - a. Include seal and signature of professional engineer on Shop Drawings.
- C. Samples: Full width and depth, 24 inches long, showing range of variation to be expected in appearance of structural glued-laminated timber, including variations due to specified treatment, if any.
1. Apply specified factory finish to 3 sides of half the length of each Sample.

1.4 INFORMATIONAL SUBMITTALS

- A. Certificates of Conformance: Issued by a qualified testing and inspecting agency indicating that structural glued-laminated timber complies with requirements in AITC A190.1.

**NISQUALLY STATE PARK
NEW FULL SERVICE PARK – PHASE 2**

- B. Research/Evaluation Reports: For structural glued-laminated timber and timber connectors, from ICC-ES.

1.5 QUALITY ASSURANCE

- A. Qualification Data:

- 1. Manufacturer Qualifications: An AITC- or APA-EWS-licensed firm.

1.6 DELIVERY, STORAGE, AND HANDLING

- A. Comply with provisions in AITC 111.
- B. Individually wrap members using plastic-coated paper covering with water-resistant seams.

PART 2 - PRODUCTS

2.1 PERFORMANCE CRITERIA

- A. Structural Performance: Structural glued-laminated timber and connectors shall withstand effects of structural loads shown on Drawings without exceeding allowable design working stresses listed in AITC 117 or determined according to ASTM D3737 and acceptable to AHJ.
- B. Seismic Performance: Structural glued-laminated timber and connectors shall withstand effects of earthquake motions determined according to ASCE 7.

2.2 STRUCTURAL GLUED-LAMINATED TIMBER

- A. Provide structural glued-laminated timber that complies with AITC A190.1 and AITC 117 or research/evaluation reports acceptable to authorities having jurisdiction.
 - 1. Factory mark each piece of structural glued-laminated timber with AITC Quality Mark or APA-EWS trademark. Place mark on surfaces that are not exposed in completed Work.
 - 2. Provide structural glued-laminated timber made from single species.
 - 3. Provide structural glued-laminated timber made from solid lumber laminations; do not use laminated veneer lumber.
- B. Species and Grades for Structural Glued-Laminated Timber: Douglas fir-larch in grades needed to comply with "Performance Criteria" Article and properties indicated on structural Drawings.
- C. Appearance Grade: Complying with AITC 110:
 - 1. Exposed to View: Architectural.
 - 2. Concealed from View: Industrial.
 - 3. For Architectural appearance grades, fill voids as required by AITC 110.
- D. Laminating Adhesive: Wet-use type complying with ASTM D2559 with AITC A190.1.

**NISQUALLY STATE PARK
NEW FULL SERVICE PARK – PHASE 2**

2.3 TIMBER CONNECTORS

- A. Manufacturers: Subject to compliance with requirements, provide products by one of the following:
 - 1. Cleveland Steel Specialty Co.
 - 2. Simpson Strong-Tie Co., Inc.
 - 3. USP Structural Connectors.
 - 4. Approved substitution.
- B. Fabricate beam seats, shoes, hangers, connectors strap ties, tie rods, and other structural steel components as indicated on structural Drawings.
- C. Fabricate steel connectors and anchors as follows or as indicated on structural Drawings:
 - 1. Bolts: ASTM A307, Grade A; 3/4 inch diameter.
 - 2. Nuts: ASTM A563.
 - 3. Flat Washers: Where indicated.
- D. Finish steel assemblies and fasteners with rust-inhibitive primer, 2 mil dry film thickness.

2.4 MISCELLANEOUS MATERIALS

- A. End Sealer: Manufacturer's standard, transparent, colorless wood sealer that is effective in retarding transmission of moisture at cross-grain cuts and is compatible with indicated finish.
- B. Penetrating Sealer: Manufacturer's standard, transparent, penetrating wood sealer that is compatible with indicated finish.

2.5 FABRICATION

- A. Shop fabricate for connections to greatest extent possible, including cutting to length and drilling bolt holes.
 - 1. Dress exposed surfaces as needed to remove planing and surfacing marks.
- B. Camber: Fabricate horizontal and inclined members with a slope of less than 1:1 with either circular or parabolic camber equal to 1/500 of span.
- C. End-Cut Sealing: Immediately after end cutting each member to final length, apply a saturation coat of end sealer to ends and other cross-cut surfaces, keeping surfaces flood coated for not less than 10 minutes.
- D. Seal Coat: After fabricating, sanding, and end-coat sealing, apply a heavy saturation coat of penetrating sealer on surfaces of each unit.

**NISQUALLY STATE PARK
NEW FULL SERVICE PARK – PHASE 2**

2.6 FACTORY FINISHING

- A. Wiped Stain Finish: Manufacturer's standard, dry-appearance, penetrating acrylic stain and sealer; oven dried and resistant to mildew and fungus.
 - 1. Color: As selected by Architect from manufacturer's full range.
- B. Clear Finish: Manufacturer's standard, 2-coat, clear varnish finish; resistant to mildew and fungus.

PART 3 - EXECUTION

3.1 EXAMINATION

- A. Examine substrates in areas to receive structural glued-laminated timber, with Installer present, for compliance with requirements, installation tolerances, and other conditions affecting performance of Work.
- B. Proceed with installation only after unsatisfactory conditions have been corrected.

3.2 INSTALLATION

- A. Erect structural glued-laminated timber true and plumb and with uniform, close-fitting joints. Provide temporary bracing to maintain lines and levels until permanent supporting members are in place.
 - 1. Handle and temporarily support glued-laminated timber, scheduled to remain exposed, to prevent surface damage, compression, and other effects that might interfere with indicated finish.
- B. Avoid extra cutting after fabrication. Where field fitting is unavoidable, comply with requirements for shop fabrication.
- C. Fitting: Fit members by cutting and restoring exposed surfaces to match specified surfacing and finishing.
 - 1. Predrill for fasteners using timber connectors as templates.
 - 2. Finish exposed surfaces to remove planing or surfacing marks, and to provide a finish equivalent to that produced by machine sanding with No. 120 grit sandpaper.
 - 3. Coat crosscuts with end sealer.
- D. Install timber connectors as indicated.
 - 1. Install bolts with same orientation within each connection and in similar connections, unless indicated otherwise.

3.3 REPAIR

- A. Repair damaged surfaces and finishes after completing erection. Replace damaged structural glued-laminated timber if repairs are not approved by Architect.

**NISQUALLY STATE PARK
NEW FULL SERVICE PARK – PHASE 2**

3.4 PROTECTION

- A. Do not remove wrappings on individually wrapped members until they no longer serve a useful purpose, including protection from weather, sunlight, soiling, and damage from Work of other trades.
 - 1. Coordinate wrapping removal with finishing Work. Retain wrapping where it can serve as a painting shield.
 - 2. Slit underside of wrapping to prevent accumulation of moisture inside wrapping.

END OF SECTION

**NISQUALLY STATE PARK
NEW FULL SERVICE PARK – PHASE 2**

SECTION 062013 – EXTERIOR FINISH CARPENTRY

PART 1 - GENERAL

1.1 SUMMARY

A. Section Includes:

1. Exterior trim.
2. Lumber soffits.

1.2 ACTION SUBMITTALS

A. Product Data: For each type of process and factory-fabricated product.

1. Indicate component materials, dimensions, profiles, textures, and colors and include construction and application details.

B. Samples for Verification:

1. For each species and cut of lumber products, with half of exposed surface finished; 50 sq. in.

1.3 INFORMATIONAL SUBMITTALS

A. Compliance Certificates:

1. For lumber that is not marked with grade stamp.

1.4 DELIVERY, STORAGE, AND HANDLING

A. Stack lumber flat with spacers between each bundle to provide air circulation.

1. Protect materials from weather by covering with waterproof sheeting, securely anchored.
2. Provide for air circulation around stacks and under coverings.

1.5 FIELD CONDITIONS

- A. Weather Limitations: Proceed with installation only when existing and forecast weather conditions permit Work to be performed and at least 1 coat of specified finish can be applied without exposure to rain, snow, or dampness.

**NISQUALLY STATE PARK
NEW FULL SERVICE PARK – PHASE 2**

- B. Do not install finish carpentry materials that are wet, moisture damaged, or mold damaged.
 - 1. Indications that materials are wet or moisture damaged include discoloration, sagging, or irregular shape.
 - 2. Indications that materials are mold damaged include fuzzy or splotchy surface contamination and discoloration.

PART 2 - PRODUCTS

2.1 FABRICATORS

- A. Engage woodworking firm acceptable to Owner and Architect that meets requirements of these Specifications.
 - 1. Do not engage woodworking firm without written approval from Owner and Architect.

2.2 MATERIALS, GENERAL

- A. Lumber: DOC PS 20 and applicable rules of grading agencies indicated. If no grading agency is indicated, comply with applicable rules of any rules-writing agency certified by the American Lumber Standard Committee's (ALSC) Board of Review.
 - 1. Grade lumber by an agency certified by ALSC's Board of Review to inspect and grade lumber under rules indicated.
 - 2. Factory mark each piece of lumber with grade stamp of inspection agency, indicating grade, species, moisture content at time of surfacing, and mill.
 - 3. For exposed lumber, mark grade stamp on end or back of each piece, or omit grade stamp and provide certificates of grade compliance issued by inspection agency.

2.3 EXTERIOR TRIM

- A. Lumber Trim for Clear Finish:
 - 1. Species and Grade:
 - a. Western red cedar; NLGA, WCLIB, or WWPA Clear MG (Mixed Grain).
 - 2. Maximum Moisture Content: 15 percent with at least 85 percent of shipment at 12 percent or less.
 - 3. Finger Jointing: Not allowed.
 - 4. Face Surface: Surfaced (smooth).

2.4 LUMBER SOFFITS

- A. Provide kiln-dried lumber siding complying with DOC PS 20.

**NISQUALLY STATE PARK
NEW FULL SERVICE PARK – PHASE 2**

- B. Species and Grade: Western red cedar; WCLIB or WWPA Clear MG (Mixed Grain).
- C. Pattern: V-edge, smooth-faced tongue and groove, actual face width (coverage) and thickness as indicated on Drawings.
- D. Texture: Lightly sanded.

2.5 MISCELLANEOUS MATERIALS

- A. Fasteners for Exterior Finish Carpentry: Provide nails or screws, in sufficient length to penetrate not less than 1-1/2 inches into wood substrate.
 - 1. For face-fastening siding, provide ringed-shank siding nails unless otherwise indicated.
 - 2. For applications not otherwise indicated, provide stainless steel fasteners.
- B. Wood Glue: Waterproof resorcinol glue recommended by manufacturer for exterior carpentry use.
- C. Flashing: Comply with requirements in Section 076200 – Sheet Metal Flashing and Trim for flashing materials installed in exterior finish carpentry.
- D. Sealants: Acrylic latex SLNT-AL1 or silyl-terminated polymer SLNT-STP2 as specified in Section 079200 – Joint Sealants, and recommended by sealant and substrate manufacturers for intended applications.

2.6 FABRICATION

- A. Back out or kerf backs of standing and running trim wider than 5 inches, except members with ends exposed in finished Work.
- B. Ease edges of lumber less than 1 inch in nominal thickness to 1/16 inch radius and edges of lumber 1 inch or more in nominal thickness to 1/8 inch radius.

2.7 FIELD FINISHING

- A. Complete fabrication, including fitting of trim pieces, before finishing.
- B. Finish faces and surfaces to be exposed.
- C. Stains and fillers may be omitted on unexposed surfaces.
- D. Transparent Finish:
 - 1. ANSI/WDMA I.S. 1A Grade: Custom.
 - 2. Architectural Woodwork Standards System-11, Polyurethane, Catalyzed.
 - 3. Staining: None required.
 - 4. Sheen: Satin.

**NISQUALLY STATE PARK
NEW FULL SERVICE PARK – PHASE 2**

PART 3 - EXECUTION

3.1 PREPARATION

- A. Clean substrates of projections and substances detrimental to application.

3.2 INSTALLATION, GENERAL

- A. Do not use materials that are unsound, warped, improperly treated or finished, inadequately seasoned, or too small to fabricate with proper jointing arrangements.
 - 1. Do not use manufactured units with defective surfaces, sizes, or patterns.
- B. Install exterior finish carpentry level, plumb, true, and aligned with adjacent materials.
 - 1. Use concealed shims where necessary for alignment.
 - 2. Scribe and cut exterior finish carpentry to fit adjoining Work.
 - 3. Refinish and seal cuts as recommended by manufacturer.
 - 4. Install to tolerance of 1/8 inch in 96 inches for level and plumb. Install adjoining exterior finish carpentry with 1/32 inch maximum offset for flush installation and 1/16 inch maximum offset for reveal installation.
 - 5. Coordinate exterior finish carpentry with materials and systems in or adjacent to it.
 - 6. Provide cutouts for mechanical and electrical items that penetrate exterior finish carpentry.
 - 7. Where face fastening is unavoidable, countersink fasteners, fill surface flush, and sand unless otherwise indicated.

3.3 INSTALLATION OF STANDING AND RUNNING TRIM

- A. Install flat-grain lumber with bark side exposed to weather.
- B. Install trim with minimum number of joints as is practical, using full-length pieces from maximum lengths of lumber available. Do not use pieces less than 24 inches long, except where necessary.
 - 1. Use scarf joints for end-to-end joints.
 - 2. Stagger end joints in adjacent and related members.
- C. Fit exterior joints to exclude water.
 - 1. Cope at returns and miter at corners to produce tight-fitting joints, with full-surface contact throughout length of joint.
 - 2. Plane backs of casings to provide uniform thickness across joints, where necessary for alignment.

3.4 INSTALLATION OF SOFFITS

- A. Install soffit lumber where indicated on Drawings with V-edge exposed to view.

**NISQUALLY STATE PARK
NEW FULL SERVICE PARK – PHASE 2**

1. Use single members for full depth of soffit.
2. Fit neatly with edge joints tight, butted at ends.
3. Blind nail with finish nails at each bearing point.
4. Install joint sealant between ends of soffit lumber and face of siding and fascia boards.
5. Install finish trim where indicated.

B. Finish: Apply finish within 2 weeks of installation.

3.5 ADJUSTING

A. Replace exterior finish carpentry that is damaged or does not comply with requirements.

1. Exterior finish carpentry may be repaired or refinished if Work complies with requirements and shows no evidence of repair or refinishing.

B. Adjust joinery for uniform appearance.

3.6 CLEANING

A. Clean exterior finish carpentry on exposed and semiexposed surfaces.

B. Touch up factory-applied finishes to restore damaged or soiled areas.

3.7 PROTECTION

A. Protect installed products from damage from weather and other causes during construction.

B. Remove and replace finish carpentry materials that are wet, moisture damaged, and mold damaged.

1. Indications that materials are wet or moisture damaged include discoloration, sagging, or irregular shape.
2. Indications that materials are mold damaged include fuzzy or splotchy surface contamination and discoloration.

END OF SECTION

**NISQUALLY STATE PARK
NEW FULL SERVICE PARK – PHASE 2**

SECTION 062023 – INTERIOR FINISH CARPENTRY

PART 1 - GENERAL

1.1 SUMMARY

A. Section Includes:

1. Interior trim.

1.2 ACTION SUBMITTALS

A. Samples for Verification:

1. For each species and cut of lumber products with nonfactory-applied finish, with half of exposed surface finished; 50 sq. in. lumber.
2. For each finish system and color of lumber products with factory-applied finish, 50 sq. in. lumber and 80 sq. in. for panels.

1.3 INFORMATIONAL SUBMITTALS

A. Qualification Data: For Installer and fabricator.

B. Product Certificates: For each type of product.

1.4 QUALITY ASSURANCE

- A. Fabricator Qualifications: Shop with minimum 5 years of documented experience that employs skilled workers who custom-fabricate products similar to those required for this Project and whose products have a record of successful in-service performance.

1.5 DELIVERY, STORAGE, AND HANDLING

A. Stack lumber flat with spacers between each bundle to provide air circulation.

1. Protect materials from weather by covering with waterproof sheeting, securely anchored.
2. Provide for air circulation around stacks and under coverings.

- B. Deliver interior finish carpentry materials only when environmental conditions comply with requirements specified for installation areas. If interior finish carpentry materials must be stored in other than installation areas, store only where environmental conditions comply with requirements specified for installation areas.

**NISQUALLY STATE PARK
NEW FULL SERVICE PARK – PHASE 2**

1.6 FIELD CONDITIONS

- A. Environmental Limitations: Do not deliver or install interior finish carpentry materials until building is enclosed and weatherproof, wet-Work in space is completed and nominally dry, and HVAC system is operating and maintaining temperature and relative humidity at occupancy levels during remainder of construction period.
- B. Do not install finish carpentry materials that are wet, moisture damaged, or mold damaged.
 - 1. Indications that materials are wet or moisture damaged include discoloration, sagging, or irregular shape.
 - 2. Indications that materials are mold damaged include fuzzy or splotchy surface contamination and discoloration.

PART 2 - PRODUCTS

2.1 MATERIALS, GENERAL

- A. Lumber: DOC PS 20 and applicable rules of grading agencies indicated. If no grading agency is indicated, comply with applicable rules of any rules-writing agency certified by American Lumber Standard Committee's (ALSC) Board of Review. Grade lumber by an agency certified by ALSC's Board of Review to inspect and grade lumber under the rules indicated.
 - 1. Factory mark each piece of lumber with grade stamp of grading agency.
 - 2. For exposed lumber, mark grade stamp on end or back of each piece or omit grade stamp and provide certificates of grade compliance issued by grading agency.

2.2 INTERIOR TRIM

- A. Lumber Trim for Opaque Finish (Painted Finish):
 - 1. Species and Grade:
 - a. AB-1: Douglas fir-larch; NLGA, WCLIB, or WWPA Superior or C & Btr finish.
 - 2. Maximum Moisture Content: 15 percent.
 - 3. Finger Jointing: Allowed.
 - 4. Face Surface: Surfaced (smooth).
 - 5. Profiles: Match existing.
 - 6. Optional Material: Primed MDF of same actual dimensions as lumber indicated may be used in lieu of lumber.

2.3 MISCELLANEOUS MATERIALS

- A. Fasteners for Interior Finish Carpentry: Nails, screws, and other anchoring devices of type, size, material, and finish required for application indicated to provide secure attachment, concealed where possible.

**NISQUALLY STATE PARK
NEW FULL SERVICE PARK – PHASE 2**

- B. Glue: Aliphatic-resin, polyurethane, or resorcinol wood glue recommended by manufacturer for general carpentry use.

2.4 FABRICATION

- A. Back out or kerf backs of the following members, except those with ends exposed in finished Work:
 - 1. Interior standing and running trim.
- B. Eased Edges: Ease edges of lumber to the following radii:
 - 1. Lumber less than 1 inch in nominal thickness: 1/16 inch.
 - 2. Lumber 1 inch or more in nominal thickness: 1/8 inch.

2.5 FIELD FINISHING

- A. Complete fabrication, including fitting of trim pieces, before finishing.
- B. Finish faces and surfaces to be exposed.
- C. Stains and fillers may be omitted on unexposed surfaces.
- D. Opaque Finish:
 - 1. Comply with requirements specified in Section 099000 – Painting and Coating.
 - 2. Match color and sheen of adjacent wall finish.

PART 3 - EXECUTION

3.1 PREPARATION

- A. Clean substrates of projections and substances detrimental to application.
- B. Before installing interior finish carpentry, condition materials to average prevailing humidity in installation areas for a minimum of 24 hours unless longer conditioning is recommended by manufacturer.

3.2 INSTALLATION, GENERAL

- A. Do not use materials that are unsound; warped; improperly treated or finished; inadequately seasoned; too small to fabricate with proper jointing arrangements; or with defective surfaces, sizes, or patterns.

**NISQUALLY STATE PARK
NEW FULL SERVICE PARK – PHASE 2**

- B. Install interior finish carpentry level, plumb, true, and aligned with adjacent materials.
 - 1. Use concealed shims where necessary for alignment.
 - 2. Where face fastening is unavoidable, countersink fasteners, fill surface flush, and sand unless otherwise indicated.
 - 3. Install to tolerance of 1/8 inch in 96 inches for level and plumb. Install adjoining interior finish carpentry with 1/32 inch maximum offset for flush installation and 1/16 inch maximum offset for reveal installation.

3.3 INSTALLATION OF TRIM

- A. Install trim with minimum number of joints as is practical, using full-length pieces from maximum lengths of lumber available.
 - 1. Do not use pieces less than 24 inches long, except where necessary.
 - 2. Stagger joints in adjacent and related standing and running trim.
 - 3. Miter at returns, miter at outside corners, and cope at inside corners to produce tight-fitting joints with full-surface contact throughout length of joint.
 - 4. Use scarf joints for end-to-end joints.
 - 5. Install trim after gypsum-board joint finishing operations are completed.
 - 6. Install without splitting; drill pilot holes before fastening where necessary to prevent splitting.
 - 7. Fasten to prevent movement or warping.
 - 8. Countersink fastener heads on exposed carpentry Work and fill holes with filler matching stain.

3.4 ADJUSTING

- A. Replace interior finish carpentry that is damaged or does not comply with requirements.
 - 1. Interior finish carpentry may be repaired or refinished if Work complies with requirements and shows no evidence of repair or refinishing.
- B. Adjust joinery for uniform appearance.

3.5 CLEANING AND PROTECTION

- A. Clean interior finish carpentry on exposed and semiexposed surfaces.
- B. Restore damaged or soiled areas and touch up factory-applied finishes if any.
- C. Protect installed products from damage from weather and other causes during construction.
- D. Remove and replace finish carpentry materials that are wet, moisture damaged, and mold damaged.

END OF SECTION

**NISQUALLY STATE PARK
NEW FULL SERVICE PARK – PHASE 2**

SECTION 064100 – ARCHITECTURAL WOOD CASEWORK

PART 1 - GENERAL

1.1 SUMMARY

A. Section Includes:

1. Wood cabinets for transparent finish.
2. Plastic-laminate-clad architectural cabinets.
3. Cabinet hardware and accessories.
4. Wood furring, blocking, shims, and hanging strips for installing architectural casework that are not concealed within other construction.
5. Shop finishing.

B. Related Requirements:

1. Section 123623.16 – Plastic-Laminate-Clad Countertops.

1.2 ADMINISTRATIVE REQUIREMENTS

A. Coordination:

1. Coordinate sizes and locations of framing, blocking, furring, reinforcements, and other related units of Work specified in other Sections to support loads imposed by installed and fully loaded casework.

B. Preinstallation Meetings: Conduct meeting at Project site.

1.3 ACTION SUBMITTALS

A. Product Data: For each type of product.

1. Include data for fire-retardant treatment from chemical-treatment manufacturer and certification by treating plant that treated materials comply with requirements.

B. Shop Drawings:

1. Include plans, sections, details, and attachments to other Work.
 - a. Detail fabrication and installation, including field joints.
2. Show direction of veining, grain, or other directional pattern.
3. Show large-scale details.
4. Show locations and sizes of furring, blocking, and hanging strips, including concealed blocking and reinforcement specified in other Sections.

**NISQUALLY STATE PARK
NEW FULL SERVICE PARK – PHASE 2**

5. Show locations and sizes of cutouts and holes for items installed in architectural casework.
6. Apply AWI Quality Certification or WI Certified Compliance Program label to Shop Drawings.

C. Samples for Verification: For the following:

1. Lumber for Transparent Finish: Not less than 5 inches wide by 12 inches long, for each species and cut, finished on one side and one edge.
2. Veneer Leaves: Representative of and selected from flitches to be used for transparent-finished casework.
3. Plastic Laminates: 12 by 12 inches, for each type, color, pattern, and surface finish required
 - a. Provide 1 sample applied to core material with specified edge material applied to 1 edge.
4. Thermally Fused Laminate (TFL) Panels: 12 by 12 inches, for each color, pattern, and surface finish.
 - a. Provide edge banding on 1 edge.
5. Corner Pieces:
 - a. Cabinet-front frame joints between stiles and rails and at exposed end pieces, 18 inches high, 18 inches wide, 6 inches deep.
 - b. Miter joints for standing trim.
6. Exposed Cabinet Hardware and Accessories: 1 full-size unit for each type and finish.

1.4 INFORMATIONAL SUBMITTALS

- A. Qualification Data: For manufacturer and Installer.
- B. Product Certificates: For the following:
 1. Composite wood products.
 2. Thermally fused laminate panels.
 3. High-pressure decorative laminate.
 4. Adhesives.
- C. Keying Schedule: Submit 1 copy detailing Owner's final keying instructions for locks.
 1. Include schematic keying diagram and index each key set to unique cabinet designations.
- D. Evaluation Reports: For fire-retardant-treated materials, from ICC-ES.

1.5 CLOSEOUT SUBMITTALS

- A. Quality Standard Compliance Certificates: AWI Quality Certification Program (QCP) or WI Certified Compliance Program (CCP) certificates.

**NISQUALLY STATE PARK
NEW FULL SERVICE PARK – PHASE 2**

1.6 QUALITY ASSURANCE

- A. Manufacturer's Qualifications: Shop that employs skilled workers who custom-fabricate products similar to those required for this Project and whose products have a record of successful in-service performance.
 - 1. Shop with a minimum 5 years of documented experience.
 - 2. Shop with at least 5 projects in the past 5 years with value of woodwork within 20 percent of cost of woodwork for this Project.
 - 3. Manufacturer's Certification: Licensed participant in AWI's Quality Certification Program (QCP) or WI's Certified Compliance Program (CCP).
- B. Installer Qualifications: Fabricator of products and licensed participant in AWI's Quality Certification Program (QCP) or WI's Certified Compliance Program (CCP).
- C. Mockups:
 - 1. Build mockups of typical architectural casework as shown on Drawings.
 - 2. Include each type of countertop specified in Division 12.
 - 3. Subject to compliance with requirements, approved mockups may become part of completed Work if undisturbed at time of Substantial Completion.

1.7 DELIVERY, STORAGE, AND HANDLING

- A. Do not deliver casework until painting and similar finish operations that might damage architectural casework have been completed in installation areas.
- B. Store casework in installation areas or in areas where environmental conditions comply with requirements specified in "Field Conditions" Article.
- C. Keep surfaces of casework covered with protective covering during handling and installation.

1.8 FIELD CONDITIONS

- A. Environmental Limitations: Do not deliver or install cabinets until building is enclosed, wet Work is complete, and HVAC system is operating and maintaining temperature and relative humidity at levels planned for building occupants during remainder of construction period.
- B. Established Dimensions: Where cabinets are indicated to fit to other construction, establish dimensions for areas where woodwork is to fit. Provide allowance for trimming at site, and coordinate construction to ensure that actual dimensions correspond to established dimensions.

**NISQUALLY STATE PARK
NEW FULL SERVICE PARK – PHASE 2**

PART 2 - PRODUCTS

2.1 FABRICATORS

- A. Engage woodworking firm acceptable to Owner and Architect that meets requirements of these Specifications.
 - 1. Do not engage woodworking firm without written approval from Owner and Architect.
- B. Source Limitations: Firm engaged to assume undivided responsibility for production of architectural wood casework shall also take responsibility for the following:
 - 1. Section 062013 – Exterior Finish Carpentry.
 - 2. Section 062023 – Interior Finish Carpentry.
 - 3. Section 123623.13 – Plastic-Laminate-Clad Countertops.

2.2 CABINETS, GENERAL

- A. Quality Standard: Unless otherwise indicated, comply with AWI's "Architectural Woodwork Standards" or WI's "North American Architectural Woodwork Standards" for grades of architectural cabinets indicated for construction, finishes, installation, and other requirements.
 - 1. Provide labels and certificates from AWI or WI certification program indicating that woodwork complies with requirements of grades specified.
 - 2. Contract Documents may contain requirements that are more stringent than referenced woodwork quality standard. Comply with requirements of Contract Documents in addition to those of referenced quality standard.

2.3 WOOD CASEWORK FOR TRANSPARENT FINISH

- A. Architectural Woodwork Standards Grade: Custom.
- B. Type of Construction: Face frame.
- C. Door and Drawer-Front Style: Reveal overlay.
 - 1. Reveal Dimension: 1/2 inch or as indicated.
- D. Wood for Exposed Surfaces:
 - 1. Species: Maple Grade B Maple.
 - 2. Cut: Plain sliced/plain sawn.
 - 3. Grain Direction: Vertically for drawer fronts, doors, and fixed panels.
 - 4. Matching of Veneer Leaves: Book match.
 - 5. Veneer Matching within Panel Face: Balance match.
- E. Semiexposed Surfaces:

**NISQUALLY STATE PARK
NEW FULL SERVICE PARK – PHASE 2**

1. Surfaces Other Than Drawer Bodies: Compatible species to that indicated for exposed surfaces, stained to match.
 - a. Edges of Thermally Fused Laminate Panel Shelves: PVC or polyester edge banding.
 2. Drawer Subfronts, Backs, and Sides: Solid-hardwood lumber, stained to match species indicated for exposed surfaces.
 3. Drawer Bottoms: Thermally fused laminate panels.
- F. Drawer Construction: Fabricate with exposed fronts fastened to subfront with mounting screws from interior of body.
1. Join subfronts, backs, and sides with glued rabbeted joints supplemented by mechanical fasteners.
- 2.4 PLASTIC-LAMINATE-CLAD ARCHITECTURAL CASEWORK
- A. Architectural Woodwork Standards Grade: Custom.
 - B. Type of Construction: Face frame.
 - C. Door and Drawer Front Style: Reveal overlay.
 1. Reveal Dimension: 1/2 inch or as indicated.
 - D. High-Pressure Decorative Laminate (HDPL): ISO 4586-3, grades as indicated or if not indicated, as required by quality standard.
 1. Manufacturers: Subject to compliance with requirements, provide specified products by one of the following or approved substitution:
 - a. Formica Corporation.
 - b. Lamin-Art, Inc.; a Wilsonart company.
 - c. Nevamar; a Panolam Industries International, Inc. brand.
 - d. Pionite; a Panolam Industries International, Inc. brand.
 - e. Wilsonart LLC; Decorative Plastic Laminates.
 - E. Laminate Cladding for Exposed Surfaces:
 1. Horizontal Surfaces: Grade HGS.
 2. Postformed Surfaces: Grade HGP.
 3. Vertical Surfaces: Grade VGS.
 4. Edges: PVC edge banding, 3.0 mm thick, matching laminate in color, pattern, and finish.
 5. Pattern Direction: Vertically for drawer fronts, doors, and fixed panels, unless indicated otherwise.
 - F. Materials for Semiexposed Surfaces:

**NISQUALLY STATE PARK
NEW FULL SERVICE PARK – PHASE 2**

1. Surfaces Other Than Drawer Bodies: High-pressure decorative laminate, ISO 4586-3, Grade VGS.
 - a. Edges of Plastic-Laminate Shelves: PVC edge banding, 3.0 mm thick, matching laminate in color, pattern, and finish.
 - b. Edges of Thermally Fused Laminate Panel Shelves: PVC or polyester edge banding.
 - c. For semiexposed backs of panels with exposed plastic-laminate surfaces, provide surface of high-pressure decorative laminate, ISO 4586-3, Grade CLS.
 2. Drawer Sides and Backs: Thermally fused laminate panels with PVC edge banding.
 3. Drawer Bottoms: Thermally fused laminate panels.
- G. Concealed Backs of Panels with Exposed Plastic-Laminate Surfaces: High-pressure decorative laminate, ISO 4586-3, Grade BKL.
- H. Drawer Construction: Fabricate with exposed fronts fastened to subfront with mounting screws from interior of body.
1. Join subfronts, backs, and sides with glued, rabbeted joints supplemented by mechanical fasteners.
- I. Colors, Patterns, and Finishes: As selected by Architect from laminate manufacturer's full range:

2.5 WOOD MATERIALS

- A. Wood Products: Provide materials that comply with requirements of referenced quality standard for each type of architectural cabinet and quality grade specified unless otherwise indicated.
1. Do not use plain-sawn softwood lumber with exposed, flat surfaces more than 3 inches wide.
 2. Wood Moisture Content: 5 to 10 percent.
- B. Composite Wood Products: Provide materials that comply with requirements of referenced quality standard for each type of wood paneling and quality grade specified unless otherwise indicated.
1. Medium-Density Fiberboard (MDF): ANSI A208.2, Grade 130.
 - a. Products: Subject to compliance with requirements, provide one of the following:
 - 1) ampine; Div. of Timber Products Company: Apex MDF.
 - 2) ARAUCO North America: Trupan Standard MDF.
 - 3) Del-Tin Fiber, LLC: Solidium Ultra MDF.
 - 4) Georgia-Pacific Wood Products LLC: UltraStock Premium MDF.
 - 5) Roseburg Forest Products Co.: Medite II.
 - 6) Timber Products Company: Masisa Ultralight MDF.
 - 7) West Fraser Timber Co., Ltd.: WestPine EcoGold MDF.
 - 8) Weyerhaeuser Company: Super-Refined MDF2.
 2. Softwood Plywood: DOC PS 1.
 3. Veneer-Faced Panel Products (Hardwood Plywood): Panels complying with HPVA HP-1.

**NISQUALLY STATE PARK
NEW FULL SERVICE PARK – PHASE 2**

4. Thermally Fused Laminate (TFL) Panels: MDF finished with thermally fused, melamine-impregnated decorative paper and complying with requirements of ISO 4586, Grade VGL, for Test Methods 3.3, 3.4, 3.6, 3.8, and 3.10.

2.6 CASEWORK HARDWARE AND ACCESSORIES

- A. Provide casework hardware and accessory materials associated with architectural casework.
- B. Frameless Concealed Hinges (European Type): ANSI/BHMA A156.9, B01602, self-closing type, 125 degrees of opening, self-closing with soft-close function.
 1. Products: Subject to compliance with requirements, provide one of the following:
 - a. Blum Inc.: CLIP top BLUMOTION.
 - b. Grass America, Inc.: TIOMOS Hinge System.
 - c. Hettich America, L.P.: Sensys Series.
 - d. Salice America Inc.: Silentia+ Series.
 - e. Sugatsune America: Olympia Series.
 - f. Approved substitution.
 2. Where indicated, provide hinge manufacturer's opening angle stop designed to limit hinge opening past 86 deg.
- C. Back-Mounted Knobs: ANSI/BHMA A156.9, B02011; back-mounted, solid metal, and as follows:
 1. Basis-of-Design Product: Subject to compliance with requirements, provide the following:
 - a. Emtek Products, Inc.: Product Code 86447.
 - b. Approved substitution.
 2. Type-1:
 - a. Profile: Rectangular.
 - b. Size: 2-1/4 inch wide, 1 inch deep.
 - c. Projection: 1 inch.
 - d. Mounting Hole CTC: 1 inch.
 - e. Material: Solid steel.
 - f. Finish: Manufacturer's flat black.
- D. Single Pole Magnetic Catches: ANSI/BHMA A156.9.
 1. Products: Subject to compliance with requirements, provide one of the following:
 - a. EPCO Engineered Products Company: Magnetic Catch – 1000.
 - b. Hafele: Item no. 246.29.703.
 - c. Knape & Vogt Mfg. Co.: 916.
 - d. Richelieu: Product # BP52030.
 - e. Sugatsune America: MC0097/WHT Magnetic Catch.
 - f. Approved substitution.

**NISQUALLY STATE PARK
NEW FULL SERVICE PARK – PHASE 2**

2. Magnet Type: Push-in, self-aligning, single pole.
 3. Enclosure: Plastic.
 4. Color: White.
 5. Holding Power: 3 lbs. minimum.
 6. Provide 1 per door unless indicated otherwise.
- E. Door and Drawer Locks:
1. Products: Subject to compliance with requirements, provide one of the following:
 - a. CompX National: C817 Series.
 - b. Olympus Locks, Inc.: 100DR/200DW N Series.
 - c. Richelieu: Product No. 1403 Series Lock.
 - d. Sugatsune America: 8810-24 Series Cabinet Lock.
 - e. Approved substitution.
 2. Design Criteria:
 - a. Casework Within a Room: Key alike.
 - b. Casework in Each Room: Key separately.
 - c. Key casework to match Owner's master keying system using removable cores.
 - d. Key Quantities: For each lock, provide the following:
 - 1) Operating Keys: 3.
 - 2) Master Keys: 6
 - 3) Key Blanks 12.
 3. Standards: Comply with ANSI/BHMA A156.11, Grade 1.
 - a. Door Locks: ANSI/BHMA A156.11, E07121.
 - b. Drawer Locks: ANSI/BHMA A156.11, E07041.
 4. Type: Surface-mounted, sliding deadbolt.
 5. Body: Die cast zinc.
 6. Overall Size: 1-1/4 inch wide, 1-5/8 inch high, 1/2 inch deep.
 7. Cylinder: Solid brass, 5-pin tumbler; re-keyable.
 8. Cylinder Length: 7/8 Inch.
 9. Cylinder Diameter: 7/8 inch.
 10. Deadbolt Size: 3/16 inch thick by 2 inch long.
 11. Deadbolt Projection: 3/4 inch.
- F. Door and Drawer Silencers: Self-adhering, clear, silicone rubber.
1. Doors: Provide 1 silencer at top and bottom of closing edge of each swinging door.
 2. Drawers: Provide 1 silencer on back side of drawer front at each corner.
- G. Shelf Support Pins: Stainless steel shelf support pin.
1. Products: Subject to compliance with requirements, provide one of the following:

**NISQUALLY STATE PARK
NEW FULL SERVICE PARK – PHASE 2**

- a. Hafele: Item no. 282.04.711.
 - b. Knappe & Vogt: 332 Series.
 - c. McMaster-Carr: 1741A2 Series Push-In Mount Supports.
 - d. Richelieu: 2291180 Metal Shelf Pin.
2. Pin Diameter: 5 mm.
 3. Pin Length: 8 mm (5/16 inch).
 4. Shelf Rest: 8 mm wide, 11 mm long (5/16 inch wide, 7/16 inch long).
 5. Finish: Stainless steel, anochrome, or nickel plated.

2.7 DRAWER SLIDES

A. Drawer Slides: ANSI/BHMA A156.9, B05091; Side mounted unless indicated otherwise; with soft or quite close functions, extension as indicated; disconnect function as indicated, zinc-plated steel ball-bearing slides, in Grades or load capacities indicated.

1. Basis-of-Design Manufacturer: Subject to compliance with requirements, provide specified products from Knappe & Vogt Mfg. Co. Knappe & Vogt or approved substitutions from one of the following:

- a. Accuride International.
- b. Hettich America, L.P.
- c. Richelieu.
- d. Sugatsune America.

B. Light Duty Slides:

1. Basis-of-Design Product: Subject to compliance with requirements, provide the following:

- a. Knappe & Vogt Mfg. Co.: KV 4450 Full Extension Soft-Close Low Profile Drawer Slide.
- b. Approved substitution.

2. Load Capacity: 65 lbs.
3. Travel: Full extension with hold-out/hold-in detents.
4. Action: Telescopic.
5. Mounting: Underside of top surface.
6. Drawer Width: Maximum 24 inches wide.
7. Disconnect Type: Lever.

C. Medium-Duty Drawer Slides:

1. Basis-of-Design Product: Subject to compliance with requirements, provide the following:

- a. Knappe & Vogt Mfg. Co.: 8450FM Full Extension Soft-Closing Drawer Slide.
- b. Approved substitution.

2. Load Capacity: 100 lbs.
3. Travel: Full extension.

**NISQUALLY STATE PARK
NEW FULL SERVICE PARK – PHASE 2**

4. Mounting: Side surfaces.
 5. Drawer Width: Maximum 24 inches wide.
 6. Disconnect Type: Lever.
- D. Heavy-Duty File Drawer Slides:
1. Basis-of-Design Product: Subject to compliance with requirements, provide the following:
 - a. Knap & Vogt Mfg. Co.: KV 4450 Full Extension Soft-Close Low Profile Drawer Slide.
 - b. Approved substitution.
 2. Load Capacity: 150 lbs.
 3. Travel: Full extension, with soft-close function.
 4. Action: Telescopic.
 5. Mounting: Side surfaces.
 6. Drawer Width: Maximum 36 inches wide.
 7. Disconnect Type: Butterfly lever.
- E. Exposed Hardware Finishes: For exposed hardware, provide finish that complies with ANSI/BHMA A156.18 for BHMA finish number indicated, unless indicated otherwise.
1. Satin Chromium Plated: ANSI/BHMA 626 for brass or bronze base; ANSI/BHMA 652 for steel base.
 2. Satin Stainless Steel: ANSI/BHMA 630.
- F. For concealed hardware, provide manufacturer's standard finish that complies with product class requirements in ANSI/BHMA A156.9.
- 2.8 GROMMETS
- A. Grommets, General (GROM): Molded-plastic or metal grommets with matching caps for wire management, trash, recycling, and paper, and as indicated.
1. Manufacturers: Subject to compliance with requirements, provide products from the following:
 - a. Bainbridge Manufacturing, Inc.
 - b. Doug Mockett & Company, Inc.
 - c. Byrne Electrical Specialists.
 - d. Hafele America, Co.
 - e. Hardware Concepts, Inc.
 - f. Richelieu.
 - g. Approved substitutions.
- B. Paper Slots: Molded-plastic paper-slot liner with 1/4 inch lip.
1. Size: 12 inches long, 1-3/4 inches wide, 1 inch deep.
 2. Color: Black.

**NISQUALLY STATE PARK
NEW FULL SERVICE PARK – PHASE 2**

2.9 MISCELLANEOUS MATERIALS

- A. Furring, Blocking, Shims, and Hanging Strips: Softwood or hardwood lumber, kiln-dried to less than 15 percent moisture content.
 - 1. Provide fire-retardant-treated softwood lumber when required by AHJ.
- B. Anchors: Select material, type, size, and finish required for each substrate for secure anchorage. Provide metal expansion sleeves or expansion bolts for post-installed anchors. Use nonferrous-metal or hot-dip galvanized anchors and inserts at inside face of exterior walls and at floors.
- C. Countertop Supports: Concealed brackets for mounting countertops are specified in Section 055000 – Metal Fabrications.
- D. Vanity Supports: Concealed, ADA-compliant, vanity brackets for mounting vanities are specified in Section 055000 – Metal Fabrications.
- E. Adhesive for Bonding Plastic Laminate: Unpigmented contact cement or selected by fabricator to comply with requirements.
 - 1. Adhesive for Bonding Edges: Hot-melt adhesive or adhesive specified above for faces.
- F. Adhesive for Bonding Tackable Surfaces: Ultra-low VOC, water-based, solvent-free, non-flammable contact adhesive recommended by cork manufacturer.
- G. Joint Sealants: Comply with requirements of Section 079200 – Joint Sealants.

2.10 CABINET FABRICATION

- A. Sand wood lightly to remove raised grain on exposed surfaces before fabrication.
- B. Fabricate architectural casework to dimensions, profiles, and details indicated. Ease edges and corners to 1/16 inch radius unless otherwise indicated.
- C. Complete fabrication, including assembly and hardware application, to maximum extent possible before shipment to Project site.
 - 1. Disassemble components only as necessary for shipment and installation.
 - 2. Where necessary for fitting at site, provide ample allowance for scribing, trimming, and fitting.
 - 3. Trial fit assemblies at manufacturer's shop that cannot be shipped completely assembled. Install dowels, screws, bolted connectors, and other fastening devices that can be removed after trial fitting.
 - 4. Verify that various parts fit as intended and check measurements of assemblies against field measurements before disassembling for shipment.
- D. Shop-cut openings to maximum extent possible to receive hardware, appliances, plumbing fixtures, electrical Work, and similar items.

**NISQUALLY STATE PARK
NEW FULL SERVICE PARK – PHASE 2**

1. Locate openings accurately and use templates or roughing-in diagrams to produce accurately sized and shaped openings.
2. Sand edges of cutouts to remove splinters and burrs.
3. Seal edges of cutouts by saturating with varnish.

E. Shelf Support Pin Holes:

1. Provide holes vertically the entire interior height of cabinet body to within 6 inches of top and bottom of interior of cabinet body.
2. If not indicated on Drawings, bore holes 2 inches from front and back of cabinet interior cabinet body at a minimum of 1 inches on center.

2.11 SHOP FINISHING

A. Finish architectural casework at manufacturer's shop as specified in this Section. Defer only final touchup, cleaning, and polishing until after installation.

B. Preparation for Finishing: Comply with referenced quality standard for sanding, filling countersunk fasteners, sealing concealed surfaces, and similar preparations for finishing architectural cabinets, as applicable to each unit of Work.

1. Backpriming: Apply 1 coat of sealer or primer, compatible with finish coats, to concealed surfaces of cabinets.

C. Transparent Finish:

1. Architectural Woodwork Standards Grade: Custom.
2. Finish: System – 11, Polyurethane, Catalyzed.
3. Wash Coat for Closed-Grain Woods: Apply wash-coat sealer to cabinets made from closed-grain wood before staining and finishing.
4. Staining: As selected by Architect.
5. Open Finish for Open-Grain Woods: Do not apply filler to open-grain woods.
6. Filled Finish for Open-Grain Woods: After staining, apply wash-coat sealer and allow to dry. Apply paste wood filler and wipe off excess. Tint filler to match stained wood.
7. Sheen: Satin, 31-45 gloss units measured on 60 degree gloss meter per ASTM D523.

PART 3 - EXECUTION

3.1 EXAMINATION

A. Examine areas and substrates to receive casework, with Installer present, for conditions under which casework will be installed and for compliance with requirements for installation tolerances, location of framing and reinforcements, and other conditions affecting performance of casework.

B. Proceed with installation only after unsatisfactory conditions have been corrected.

**NISQUALLY STATE PARK
NEW FULL SERVICE PARK – PHASE 2**

3.2 PREPARATION

- A. Before installation, condition casework to humidity conditions in installation areas for not less than 72 hours.

3.3 INSTALLATION OF CABINETS

- A. Architectural Woodwork Standards Grade: Install cabinets to comply with quality standard grade of item to be installed.
- B. Assemble cabinets and complete fabrication at Project site to extent that it was not completed in shop.
- C. Anchor cabinets to anchors or blocking built in or directly attached to substrates.
 - 1. Secure with countersunk, concealed fasteners and blind nailing.
 - 2. Use fine finishing nails or finishing screws for exposed fastening, countersunk and filled flush with woodwork.
- D. Anchor cabinets to anchors or blocking built in or directly attached to substrates. Secure with wafer-head cabinet installation screws.
- E. Install cabinets level, plumb, and true in line to a tolerance of 1/8 inch in 96 inches using concealed shims.
 - 1. Scribe and cut cabinets to fit adjoining Work, refinish cut surfaces, and repair damaged finish at cuts.
 - 2. Install cabinets without distortion so doors and drawers fit openings and are accurately aligned. Adjust hardware to center doors and drawers in openings and to provide unencumbered operation. Complete installation of hardware and accessory items as indicated.
 - 3. Maintain veneer sequence matching of cabinets with transparent finish.
 - 4. Fasten wall cabinets through back, near top and bottom, and at ends not more than 16 inches on center with fasteners appropriate for anchoring to structure.
- F. Shop Finishes: Touch up finishing after installation of architectural cabinets. Fill nail holes with matching filler.
 - 1. Apply specified finish coats, including stains and paste fillers if any, to exposed surfaces where only sealer/prime coats are shop applied.

3.4 REPAIR

- A. Repair damaged and defective casework, where possible, to eliminate functional and visual defects.
 - 1. Where not possible to repair, replace architectural casework.
 - 2. Adjust joinery for uniform appearance.

**NISQUALLY STATE PARK
NEW FULL SERVICE PARK – PHASE 2**

3.5 FIELD QUALITY CONTROL

- A. Inspections: Provide inspection of installed Work through AWT's Quality Certification or WI's Certified Compliance Program certifying that woodwork, including installation, complies with requirements of referenced quality standards for specified grade.
 - 1. Inspection entity shall prepare and submit report of inspection.

3.6 ADJUSTING

- A. Adjust hardware so doors and drawers are centered in openings and operate smoothly without warp or bind. Lubricate operating hardware as recommended by manufacturer.

3.7 CLEANING

- A. Clean casework on exposed and semiexposed surfaces. Touch up as required to restore damaged or soiled areas to match original factory finish, as approved by Architect.

END OF SECTION

**NISQUALLY STATE PARK
NEW FULL SERVICE PARK – PHASE 2**

SECTION 064800 – WOOD FRAMES

PART 1 - GENERAL

1.1 SUMMARY

A. Section Includes:

1. Exterior frames and jambs for opaque finish.
2. Interior frames and jambs for opaque finish.
3. Shop priming wood frames and jambs.

1.2 ADMINISTRATIVE REQUIREMENTS

A. Coordination:

1. Coordinate sizes and locations of framing, blocking, furring, reinforcements, and other related units of Work specified in other Sections to ensure that wood frames can be supported and installed as indicated.

1.3 ACTION SUBMITTALS

A. Product Data: For each type of product, including finishing materials and processes.

B. Shop Drawings: Show location of each item, dimensioned plans and elevations, large-scale details, attachment devices, and other components.

1. Show details full size.
2. Show locations and sizes of concealed blocking and reinforcement specified in other Sections.

C. Samples for Verification:

1. For each species and cut of lumber, minimum 5 inches wide by 12 inches long
 - a. Opaque Finish: Finish system and color, with 1/2 exposed surface finished.

1.4 INFORMATIONAL SUBMITTALS

A. Qualification Data: For Installer and fabricator.

1.5 QUALITY ASSURANCE

A. Manufacturer's Qualifications: Shop that employs skilled workers who custom fabricate products similar to those required for this Project and whose products have a record of successful in-service performance.

**NISQUALLY STATE PARK
NEW FULL SERVICE PARK – PHASE 2**

1. Shop with a minimum 5 years of documented experience.
 2. Shop with at least 5 projects in the past 5 years with value of woodwork within 20 percent of cost of woodwork for this Project.
 3. Manufacturer's Certification: Licensed participant in AWI's Quality Certification Program (QCP) or WI's Certified Compliance Program (CCP).
- B. Installer Qualifications: Manufacturer of products and licensed participant in AWI's Quality Certification Program (QCP) or WI's Certified Compliance Program (CCP).
- C. Mockups:
1. Build mockups of typical wood frame carpentry as shown on Drawings.
 2. Subject to compliance with requirements, approved mockups may become part of completed Work if undisturbed at time of Substantial Completion.
- 1.6 DELIVERY, STORAGE, AND HANDLING
- A. Comply with the Architectural Woodwork Standards, Section 2.
 - B. Do not deliver wood frames until painting and similar finish operations that might damage woodwork have been completed in installation areas.
 - C. Store wood frames in installation areas or in areas where environmental conditions comply with requirements specified in "Field Conditions" Article.
- 1.7 FIELD CONDITIONS
- A. Environmental Limitations:
 1. Do not deliver or install wood frame materials until building is enclosed and weatherproof, wet-Work in space is completed and nominally dry, and HVAC system is operating and maintaining temperature and relative humidity at occupancy levels during remainder of construction period.
 - B. Do not install wood frame materials that are wet, moisture damaged, or mold damaged.
 1. Indications that materials are wet or moisture damaged include discoloration, sagging, or irregular shape.
 2. Indications that materials are mold damaged include fuzzy or splotchy surface contamination and discoloration.
 - C. Weather Limitations for Exterior Work: Proceed with installation of exterior wood frames only when existing and forecasted weather conditions permit Work to be performed and at least 1 coat of specified finish has been applied.
 - D. Established Dimensions: Where wood frames are indicated to fit to other construction, establish dimensions for areas where wood frames are to fit. Coordinate construction to ensure that actual dimensions correspond to established dimensions.

**NISQUALLY STATE PARK
NEW FULL SERVICE PARK – PHASE 2**

PART 2 - PRODUCTS

2.1 FABRICATORS

- A. Engage woodworking firm acceptable to Owner and Architect that meets requirements of these Specifications.
 - 1. Do not engage woodworking firm without written approval from Owner and Architect.

2.2 EXTERIOR FRAMES AND JAMBS FOR OPAQUE FINISH

- A. Architectural Woodwork Standards Grade: Custom.
- B. Wood Species: Any closed-grain hardwood.
 - 1. Do not use plain-sawn softwood lumber with exposed, flat surfaces more than 3 inches wide.
 - 2. Wood Moisture Content: 10 to 15 percent.
 - 3. Finger Jointing: Not allowed.
 - 4. Face Surface: Surfaced (smooth).
 - 5. Factory Priming: Factory coated on both faces and all edges, with exterior primer compatible with topcoats specified.
 - 6. Optional Material: Primed MDF of same actual dimensions as lumber indicated may be used in lieu of lumber.

2.3 INTERIOR FRAMES AND JAMBS FOR OPAQUE FINISH

- A. Architectural Woodwork Standards Grade: Custom.
- B. Wood Species: Any closed-grain hardwood.
 - 1. Do not use plain-sawn softwood lumber with exposed, flat surfaces more than 3 inches wide.
 - 2. Wood Moisture Content: 8 to 13 percent.
 - 3. Optional Material: Primed MDF of same actual dimensions as lumber indicated may be used in lieu of lumber.

2.4 MISCELLANEOUS MATERIALS

- A. Fasteners for Interior Finish Carpentry: Nails, screws, and other anchoring devices of type, size, material, and finish required for application indicated to provide secure attachment, concealed where possible.
- B. Fasteners for Exterior Finish Carpentry: Provide nails or screws, in sufficient length to penetrate not less than 1-1/2 inches into wood substrate.
 - 1. For face-fastening siding, provide ringed-shank siding nails[unless otherwise indicated].
 - 2. Provide stainless steel fasteners unless indicated otherwise.

**NISQUALLY STATE PARK
NEW FULL SERVICE PARK – PHASE 2**

3. For prefinished items, provide matching prefinished aluminum fasteners where face fastening is required.

2.5 FABRICATION OF WOOD FRAMES

- A. Fabricate wood frames to dimensions, profiles, and details indicated. Ease edges to radius indicated.
- B. Exterior Frames and Jambs:
 1. Back out or kerf backs of standing and running trim wider than 5 inches, except members with ends exposed in finished Work.
 2. Ease edges of lumber less than 1 inch in nominal thickness to 1/16 inch radius and edges of lumber 1 inch or more in nominal thickness to 1/8 inch radius.
- C. Interior Frames and Jambs:
 1. Back out or kerf backs of members, except those with ends exposed in finished Work:
 2. Ease edges of lumber less than 1 inch in nominal thickness to 1/16 inch radius and edges of lumber 1 inch or more in nominal thickness to 1/8 inch radius.

2.6 FINISHES, GENERAL

- A. Preparations for Finishing: Comply with Architectural Woodwork Standards for sanding, filling countersunk fasteners, sealing concealed surfaces, and similar preparations for finishing interior architectural woodwork, as applicable to each unit of Work.
- B. Complete fabrication, including fitting doors for openings and machining for hardware that is not surface applied, before finishing.
 1. Finish faces, all 4 edges, edges of cutouts, and mortises.
 2. Stains and fillers may be omitted on bottom edges, edges of cutouts, and mortises.
- C. Backpriming: Apply 1 coat of sealer or primer, compatible with finish coats, to concealed surfaces of wood frames.
 1. Apply 2 coats to end-grain surfaces.

2.7 SHOP PRIMING

- A. Exterior Wood Frames for Opaque Finish:
 1. Shop prime with 1 coat of wood primer specified in Section 099000 –Painting and Coating.
- B. Interior Wood Frames for Opaque Finish:
 1. Shop prime with 1 coat of wood primer specified in Section 099000 –Painting and Coating.

**NISQUALLY STATE PARK
NEW FULL SERVICE PARK – PHASE 2**

2.8 FIELD FINISHING

- A. Finish wood frames with opaque finish.
 - 1. Defer only final touchup, cleaning, and polishing until after installation.
 - 2. Stains and fillers may be omitted on unexposed surfaces.
- B. Opaque Finish: Comply with Section 099000 –Painting and Coating.

PART 3 - EXECUTION

3.1 EXAMINATION

- A. Examine substrates, with Installer present, for compliance with requirements for installation tolerances and other conditions affecting performance of Work.
- B. Examine wood frames before installation. Reject materials that are wet, moisture damaged, and mold damaged.
- C. Proceed with installation only after unsatisfactory conditions have been corrected.

3.2 PREPARATION

- A. Clean substrates of projections and substances detrimental to application.
- B. Before installing interior wood frames, ensure materials have been conditioned to average prevailing humidity in installation areas for a minimum of 24 hours unless longer conditioning is recommended by manufacturer.
- C. Prime lumber and moldings to be painted, including both faces and edges, unless factory primed.
 - 1. Cut to required lengths and prime ends.
 - 2. Comply with requirements in Section 099000 –Painting and Coating.

3.3 INSTALLATION OF WOOD FRAMES

- A. Do not use materials that are unsound; warped; improperly treated or finished; inadequately seasoned; too small to fabricate with proper jointing arrangements; or with defective surfaces, sizes, or patterns.
- B. Install wood frames with minimum number of joints as is practical, using full-length pieces from maximum lengths of lumber available.
 - 1. Do not use pieces less than 24 inches long, except where necessary.
 - 2. Use scarf joints for end-to-end joints.
 - 3. Stagger joints in adjacent and related materials.

**NISQUALLY STATE PARK
NEW FULL SERVICE PARK – PHASE 2**

4. Miter at returns, miter at outside corners, and cope at inside corners to produce tight-fitting joints with full-surface contact throughout length of joint.
 5. Plane backs of casings to provide uniform thickness across joints where necessary for alignment.
- C. Install wood frames level, plumb, true, and aligned with adjacent materials.
1. Use concealed shims where necessary for alignment.
 2. Scribe and cut wood frames to fit adjoining Work.
 - a. Refinish and seal cuts as recommended by manufacturer.
 3. Install to tolerance of 1/8 inch in 96 inches for level and plumb.
 4. Coordinate wood frames with materials and systems in or adjacent to it.
 5. Where face fastening is unavoidable, countersink fasteners, fill surface flush, and sand unless otherwise indicated.
 6. Install without splitting; drill pilot holes before fastening where necessary to prevent splitting.
 7. Fasten to prevent movement or warping.
- D. Exterior Wood Frames:
1. Install flat-grain lumber with bark side exposed to weather.
 2. Fit exterior joints to exclude water.
- E. Interior Wood Frames:
1. Install trim after gypsum-board joint finishing operations are completed.
- F. Touch up Work after installation of wood frames. Fill nail holes with matching filler where exposed.
1. Apply specified finish coats, including stains and paste fillers if any, to exposed surfaces where only sealer/prime coats are applied in shop.
- G. Refer to Section 099000 –Painting and Coating for final finishing of installed wood frames indicated to be field finished.
- 3.4 ADJUSTING
- A. Replace wood frames that are damaged, defective, or do not comply with requirements.
1. Wood frames may be repaired or refinished if Work complies with requirements, shows no evidence of repair or refinishing, and is approved in writing by Architect.
- B. Adjust joinery for uniform appearance.
- 3.5 CLEANING
- A. Clean wood frames on exposed and semiexposed surfaces.

**NISQUALLY STATE PARK
NEW FULL SERVICE PARK – PHASE 2**

- B. Touch up finishes to restore damaged or soiled areas.

3.6 PROTECTION

- A. Protect installed products from damage from weather and other causes during construction.
- B. Remove and replace wood frames that are wet, moisture damaged, and mold damaged.

END OF SECTION

**NISQUALLY STATE PARK
NEW FULL SERVICE PARK – PHASE 2**

SECTION 066400 – PLASTIC PANELING

PART 1 - GENERAL

1.1 SUMMARY

A. Section Includes:

1. Glass-fiber-reinforced plastic sheet paneling.

1.2 ACTION SUBMITTALS

A. Product Data: For each type of product.

B. Samples: For plastic paneling and trim accessories, in manufacturer's standard sizes.

1.3 PROJECT CONDITIONS

- A. Environmental Limitations: Do not deliver or install plastic paneling until spaces are enclosed and weathertight and temporary HVAC system is operating and maintaining ambient temperature and humidity conditions at occupancy levels during remainder of construction period.

PART 2 - PRODUCTS

2.1 PLASTIC SHEET PANELING

- A. Glass-Fiber-Reinforced Plastic (FRP) Paneling: Gelcoat-finished, glass-fiber-reinforced plastic panels complying with ASTM D5319. Provide panels labeled for compliance with USDA requirements for incidental food contact.

1. Products: Subject to compliance with requirements, provide FRP-1 as specified in Material and Finish Legend on Drawings or approved substitution.
2. Surface-Burning Characteristics: Class A when tested according to ASTM E84.
 - a. Flame-Spread Index: 25 or less.
 - b. Smoke-Developed Index: 450 or less.
3. Mold Resistance: ASTM D3273, does not support mold or mildew according to ASTM D3274.
4. Scratch Resistance: ASTM D2583, Barcol Hardness of 40.
5. Abrasion Resistance: Taber Abrasion Test using CS-17 abrasive wheels with 1,000 g weight.
 - a. Panels shall exhibit weight loss after 25 cycles of no more than 0.038 percent.

**NISQUALLY STATE PARK
NEW FULL SERVICE PARK – PHASE 2**

6. Impact Resistance: ASTM D256; 3.0 lbf/in., Izod Impact Strength, Notched (73 deg).
7. Flexural Strength: ASTM D790; 14,0669 psi minimum.
8. Flexural Modulus: ASTM D790; 400,014 psi minimum.
9. Tensile Strength: ASTM D638; 899,959 psi minimum.
10. Nominal Thickness: Not less than 0.094 inch.
11. Surface Finish: Molded pebble texture, unless indicated otherwise.

- B. Source Limitations: Obtain plastic paneling and trim accessories from single manufacturer.

2.2 ACCESSORIES

- A. Trim Accessories: Manufacturer's standard 1-piece extrusions designed to retain and cover edges of panels. Provide division bars, inside corners, outside corners, and caps as needed to conceal edges.
1. Color: Match plastic paneling.
- B. Exposed Fasteners: Nylon drive rivets recommended by panel manufacturer.
- C. Sealant: SLNT-S3 or SLNT-STP1 as specified in Section 079200 – Joint Sealants.

PART 3 - EXECUTION

3.1 EXAMINATION

- A. Examine substrates and conditions, with Installer present, for compliance with requirements for installation tolerances and other conditions affecting performance of Work.
- B. Proceed with installation only after unsatisfactory conditions have been corrected.

3.2 PREPARATION

- A. Clean substrates of substances that could impair adhesive bond, including oil, grease, dirt, and dust.
- B. Condition panels by unpacking and placing in installation space before installation according to manufacturer's written recommendations.
- C. Lay out paneling before installing. Locate panel joints to provide equal panels at ends of walls not less than half the width of full panels and so that trimmed panels at corners are not less than 12 inches wide.
1. Mark plumb lines on substrate at panel joint locations for accurate installation.
 2. Locate panel joints to allow clearance at panel edges according to manufacturer's written instructions.

**NISQUALLY STATE PARK
NEW FULL SERVICE PARK – PHASE 2**

3.3 INSTALLATION

- A. Install plastic paneling according to manufacturer's written instructions.
- B. Install panels with fasteners. Layout fastener locations and mark on face of panels so that fasteners are accurately aligned.
 - 1. Drill oversized fastener holes in panels and center fasteners in holes.
 - 2. Apply sealant to fastener holes before installing fasteners.
- C. Install trim accessories with adhesive.
- D. Fill grooves in trim accessories with sealant before installing panels, and bed inside corner trim in a bead of sealant.
- E. Maintain uniform space between panels and wall fixtures. Fill space with sealant.
- F. Remove excess sealant and smears as paneling is installed. Clean with solvent recommended by sealant manufacturer and then wipe with clean dry cloths until no residue remains.

END OF SECTION

**NISQUALLY STATE PARK
NEW FULL SERVICE PARK – PHASE 2**

SECTION 067413 – ECOGRATE

PART 1 - GENERAL

1.1 DESCRIPTION

- A. Furnish, fabricate (where necessary), and install all fiberglass reinforced plastic (FRP) items, with all appurtenances, accessories and incidentals necessary to produce a complete, operable and serviceable installation as shown on the Drawings and as specified herein, and in accordance with the requirements of the Contract Documents.

1.2 REFERENCE STANDARDS:

- A. Conform to requirements of the following Reference Standards or as modified and supplemented hereinafter.
 - 1. American Society for Testing and Materials (ASTM) Test Methods:
 - a. ASTM D 635 Rate of Burning and/or Extent and Time of Burning of Self-Supporting Plastics in a Horizontal Position
 - b. ASTM D 732 Shear Strength of Plastics by Punch Tool
 - c. ASTM E 84 Surface Burning Characteristics of Building Materials

1.3 SUBMITTALS

- A. Furnish shop drawings of all fabricated gratings and accessories in accordance with the provisions of this Section.
- B. Furnish manufacturer's shop drawings clearly showing material sizes, types, styles, part or catalog numbers, complete details for the fabrication of and erection of components including, but not limited to, location, lengths, type and sizes of fasteners, clip angles, member sizes, and connection details.
- C. Submit the manufacturer's published literature including structural design data, structural properties data, grating load/deflection tables, corrosion resistance tables, certificates of compliance, test reports as applicable, concrete anchor systems and their allowable load tables, and design calculations for systems not sized or designed in the contract documents.
- D. Submit literature for tamper-proof fasteners that are not standard components of pultruded grating assembly.
- E. Submit sample pieces of pultruded grating for review of color and load bar spacing/size.

**NISQUALLY STATE PARK
NEW FULL SERVICE PARK – PHASE 2**

1.4 QUALITY ASSURANCE:

- A. Conform to requirements of the following Reference Standards or as modified and supplemented within this specification.
 - 1. International Building Code (IBC)
- B. Conformance with Standards and Tests: Materials and handling shall conform to the following organizations' standards for materials testing and handling. Each standard is hereafter referred to by its organizational designation only. All materials and handling techniques shall conform to the appropriate standard.
- C. All items to be provided under this Section shall be furnished only by manufacturers having a minimum of ten (10) years' experience in the design and manufacture of similar products and systems. Additionally, if requested, a record of at least five (5) previous, separate, similar successful installations in the last five (5) years shall be provided.
- D. Manufacturer shall offer a 3-year limited warranty on all FRP products against defects in materials and workmanship.
- E. Manufacturer shall be certified to the ISO 9001-2000 standard.
- F. Manufacturer shall provide proof of certification from at least two other quality assurance programs for its facilities or products (UL, DNV, ABS, USCG, AARR).
- G. Manufacturer shall provide proof, via independent testing less than six months old, that materials proposed as a solution do not contain heavy metals in amounts greater than that allowed by current EPA requirements.
- H. To meet quality standards and assure grating meets all EPA requirements, grating must be manufactured in North America.

1.5 PRODUCT DELIVERY AND STORAGE

- A. Delivery of Materials: Manufactured materials shall be delivered in original, unbroken pallets, packages, containers, or bundles bearing the label of the manufacturer. Adhesives, resins and their catalysts and hardeners shall be crated or boxed separately and noted as such to facilitate their movement to a dry indoor storage facility.
- B. Storage of Products: All materials shall be carefully handled to prevent them from abrasion, cracking, chipping, twisting, other deformations, and other types of damage. Store items in an enclosed area and free from contact with soil and water. Store adhesives, resins and their catalysts and hardeners in dry indoor storage facilities between 70- and 85-degrees Fahrenheit (21 to 29 degrees Celsius) until they are required.

**NISQUALLY STATE PARK
NEW FULL SERVICE PARK – PHASE 2**

PART 2 - PRODUCTS

2.01 MANUFACTURER

- A. Molded grating shall be 4’x10’ Ecograte® 62 Molded Grating, or equal, as manufactured by the following.

Fibergrate Composite Structures Inc.
5151 Belt Line Road, Suite 700
Dallas, Texas 75254-7028 USA (503) 554-0419
mkeidel@fibergrate.com

2.2 GENERAL

- A. All FRP items furnished under this Section shall be composed of fiberglass reinforcement and resin in qualities, quantities, properties, arrangements, and dimensions as necessary to meet the design requirements and dimensions as specified in the Contract Documents.
- B. Fiberglass reinforcement shall be a combination of continuous roving, continuous strand mat, and surfacing veil in sufficient quantities as needed by the application and/or physical properties required.
- C. Resins shall be isophthalic with chemical formulations as necessary to provide the corrosion resistance, strength, and other physical properties as required.
- D. All finished surfaces of FRP items and fabrications shall be smooth, resin-rich, free of voids and without dry spots, cracks, crazes, or unreinforced areas. All glass fibers shall be well covered with resin to protect against their exposure due to wear or weathering.
- E. All materials shall be further protected from ultraviolet (UV) light with 1) integral UV inhibitors in the resin and 2) a synthetic surfacing veil to help produce a resin rich surface.
- F. All FRP products shall have a tested flame spread rating of 15 or less per ASTM
- G. E-84 Tunnel Test. Gratings shall also have a tested burn time of less than 30 seconds and an extent of burn rate of less than or equal to 10 millimeters per ASTM D635.
- H. All grating clips shall be manufactured of Type 316SS (stainless steel).
- I. Fasteners shall be tamper-proof, and of one type.

2.3 MOLDED FRP GRATING

- A. Manufacture: Grating shall be of a one piece molded construction with tops and bottoms of bearing bars and cross bars in the same plane. Grating shall have a rectangular mesh pattern providing unidirectional strength. Grating shall be reinforced with continuous rovings of equal number of layers in each direction. The top layer of reinforcement shall be no more than 1/8" below the top surface of the grating so as to provide maximum stiffness and prevent resin chipping of unreinforced surfaces. Percentage of glass (by weight) shall not exceed 35% so as to achieve

**NISQUALLY STATE PARK
NEW FULL SERVICE PARK – PHASE 2**

maximum corrosion resistance, and as required to maintain the structural requirements of the Contract.

- B. After molding, no dry glass fibers shall be visible on any surface of bearing bars or cross bars. All bars shall be smooth and uniform with no evidence of fiber orientation irregularities, interlaminar voids, porosity, resin rich or resin starved areas.
- C. (infrared) oven to the top surface of the finished grating product to assure a durable, slip and UV resistant finish.
- D. Grating bar intersections are to be filleted to a minimum radius of 1/16”.
- E. Fire rating: Grating shall be fire retardant with a tested flame spread rating of 25 or less when tested in accordance with ASTM E 84. Data performed only on the resin shall not be acceptable.
- F. Resin system: The resin system used in the manufacture of the grating shall be selected by the manufacture for applicable use for the site conditions and exposure. Manufacturer may be required to submit corrosion data from tests performed on actual grating products in standard chemical environments. Corrosion resistance data of the base resin from the manufacturer is not a true indicator of grating corrosion resistance and shall not be accepted.
- G. Color: Brown
- H. Depth: 1" deep load bars with a tolerance of plus or minus 1/16".
- I. Mesh Configuration: 1" load bar spacing on centers; 4" tie bar spacing on centers.
- J. Load/Deflection: Grating shall meet manufacturers published safe recommended loadings with deflection not to exceed the following:
 - 1. Uniform distributed load over a 42" span: 50 pounds per square foot, with a maximum deflection of 0.12".
- K. Substitutions: Other products of equal strength, stiffness, corrosion resistance and overall quality may be submitted with the proper supporting data to Owner for approval.

2.4 GRATING FABRICATION

- A. Measurements: Grating supplied shall meet the minimum dimensional requirements as shown or specified. The Contractor shall provide and/or verify measurements in field for work fabricated to fit field conditions as required by grating manufacturer to complete the work. Determine correct size and locations of required holes or cutouts from field dimensions before grating fabrication.
- B. Layout: Each grating section shall be readily removable, except where indicated on Drawings. Manufacturer to provide openings and holes where located on the Contract Drawings. Grating supports shall be provided at openings in the grating by Contractor where necessary to meet load/deflection requirements specified herein. Grating openings which fit around protrusions (pipes, cables, machinery, etc.) shall be discontinuous at approximately the centerline of opening so each section of grating is readily removable. Grating supports shall be added at the intersection

**NISQUALLY STATE PARK
NEW FULL SERVICE PARK – PHASE 2**

of grating panels by contractor where necessary to meet load/deflection requirements specified herein.

- C. Sealing: All shop fabricated grating cuts shall be coated with vinyl ester resin to provide maximum corrosion resistance. All field fabricated grating cuts shall be coated similarly by the Contractor in accordance with the manufacturer's instructions.
- D. Hardware: Type 316 stainless steel hold-down clips shall be provided and spaced at a maximum of four feet apart with a minimum of four per piece of grating, or as recommended by the manufacturer.

PART 3 - EXECUTION

3.1 INSPECTION

- A. Shop inspection is authorized as required by the Owner and shall be at Owner's expense. The fabricator shall give ample notice to Contractor prior to the beginning of any fabrication work so that inspection may be provided.
- B. The grating shall be as free, as commercially possible, from visual defects such as foreign inclusions, delamination, blisters, resin burns, air bubbles and pits.

3.2 INSTALLATION

- A. Contractor shall install gratings in accordance with manufacturer's assembly drawings. Lock grating panels securely in place with hold-down fasteners as specified herein. Field cut and drill fiberglass reinforced plastic products with carbide or diamond tipped bits and blades. Seal cut or drilled surfaces in accordance with manufacturer's instructions. Follow manufacturer's instructions when cutting or drilling fiberglass products or using resin products; provide adequate ventilation.

END OF SECTION

**NISQUALLY STATE PARK
NEW FULL SERVICE PARK – PHASE 2**

SECTION 071113 – BITUMINOUS DAMPPROOFING

PART 1 - GENERAL

1.1 SUMMARY

A. Section Includes:

1. Cold-applied, emulsified-asphalt dampproofing.

1.2 ACTION SUBMITTALS

- A. Product Data: For each type of product.

1.3 FIELD CONDITIONS

- A. Weather Limitations: Proceed with application only when existing and forecasted weather conditions permit dampproofing to be performed according to manufacturers' written instructions.
- B. Ventilation: Provide adequate ventilation during application of dampproofing in enclosed spaces. Maintain ventilation until dampproofing has cured.

PART 2 - PRODUCTS

2.1 MANUFACTURERS

- A. Source Limitations: Obtain primary dampproofing materials and primers from single source from single manufacturer. Provide auxiliary materials recommended in writing by manufacturer of primary materials.

2.2 COLD-APPLIED, EMULSIFIED-ASPHALT DAMPPROOFING

- A. Dampproofing: Spray-grade, emulsion dampproof coating that impedes vapor on exterior above and below grade surfaces not subject to hydrostatic pressure.
1. Products: Subject to compliance with requirements, provide 1 of the following:
 - a. Henry Company: Henry 788 Non-Fibered Asphalt Emulsion Damp Proofing.
 - b. Karnak Corp.: 100 Non-Fibered Emulsion Dampproofing.
 - c. Master Builders Solutions: MasterSeal 610.
 - d. W. R. Meadows, Inc.: Sealmatic Type I.

**NISQUALLY STATE PARK
NEW FULL SERVICE PARK – PHASE 2**

2.3 AUXILIARY MATERIALS

- A. Furnish auxiliary materials recommended in writing by dampproofing manufacturer for intended use and compatible with bituminous dampproofing.
- B. Emulsified-Asphalt Primer: ASTM D1227, Type III, Class 1, except diluted with water as recommended in writing by manufacturer.
- C. Asphalt-Coated Glass Fabric: ASTM D1668, Type I.
- D. Patching Compound: Asbestos-free fibered mastic of type recommended in writing by dampproofing manufacturer.

PART 3 - EXECUTION

3.1 EXAMINATION

- A. Examine substrates, areas, and conditions, with Applicator present, for compliance with requirements for surface smoothness, maximum surface moisture content, and other conditions affecting performance of Work.
- B. Proceed with application only after substrate construction and penetrating work have been completed and unsatisfactory conditions have been corrected.

3.2 PREPARATION

- A. Clean, prepare, and treat substrates according to manufacturer's written instructions. Provide clean, dust-free, and dry substrates for dampproofing application.
- B. Mask or otherwise protect adjoining exposed surfaces from being stained, spotted, or coated with dampproofing. Prevent dampproofing materials from entering and clogging weep holes and drains.
- C. Clean substrates of projections and substances detrimental to dampproofing Work; fill voids, seal joints, and remove bond breakers if any.
- D. Apply patching compound to patch and fill tie holes, honeycombs, reveals, and other imperfections.

3.3 APPLICATION, GENERAL

- A. Comply with manufacturer's written instructions for dampproofing application, cure time between coats, and drying time before backfilling unless otherwise indicated.
 - 1. Apply dampproofing to provide continuous plane of protection.
 - 2. Apply additional coats if recommended in writing by manufacturer or to achieve a smooth surface and uninterrupted coverage.

**NISQUALLY STATE PARK
NEW FULL SERVICE PARK – PHASE 2**

- B. Where dampproofing footings and foundation walls, apply from finished-grade line to top of footing; extend over top of footing and down a minimum of 6 inches over outside face of footing.
 - 1. Extend dampproofing 12 inches onto intersecting walls and footings, but do not extend onto surfaces exposed to view when Project is completed.
 - 2. Install flashings and corner protection stripping at internal and external corners, changes in plane, construction joints, cracks, and where indicated as "reinforced," by embedding an 8-inch-wide strip of asphalt-coated glass fabric in a heavy coat of dampproofing. Dampproofing coat for embedding fabric is in addition to other coats required.
- C. Where dampproofing exterior face of inner wythe of exterior masonry cavity walls, lap dampproofing at least 1/4 inch onto flashing, masonry reinforcement, veneer ties, and other items that penetrate inner wythe.
 - 1. Extend dampproofing over outer face of structural members and concrete slabs that interrupt inner wythe.
 - 2. Lap dampproofing at least 1/4 inch onto shelf angles supporting veneer.
- D. Where dampproofing interior face of above-grade, exterior concrete walls, continue dampproofing through intersecting walls by keeping vertical mortar joints at intersection temporarily open or by dampproofing wall before constructing intersecting walls.

3.4 COLD-APPLIED, EMULSIFIED-ASPHALT DAMPPROOFING

- A. Concrete Foundations: Apply 2 brush or spray coats at not less than 1.5 gal./100 sq. ft. for first coat and 1 gal./100 sq. ft. for second coat.

3.5 PROTECTION

- A. Protect installed insulation drainage panels from damage due to UV light, harmful weather exposures, physical abuse, and other causes. Provide temporary coverings where panels are subject to abuse and cannot be concealed and protected by permanent construction immediately after installation.
- B. Correct dampproofing that does not comply with requirements; repair substrates, and reapply dampproofing.

END OF SECTION

**NISQUALLY STATE PARK
NEW FULL SERVICE PARK – PHASE 2**

SECTION 072100 – THERMAL INSULATION

PART 1 - GENERAL

1.1 SUMMARY

A. Section Includes:

1. Extruded polystyrene foam-plastic board insulation.
2. Polyisocyanurate foam-plastic board insulation.
3. Glass-fiber blanket insulation.
4. Spray foam sealant.
5. Vapor retarders.

B. Related Requirements:

1. Section 074113.16 – Standing-Seam Metal Roof Panels.

1.2 ACTION SUBMITTALS

- A. Product Data: For each type of product.

1.3 INFORMATIONAL SUBMITTALS

- A. Installer's Certification: Listing type, manufacturer, and R-value of insulation installed in each element of building thermal envelope.
- B. Product Test Reports: For each product, for tests performed by a qualified testing agency.
- C. Evaluation Reports: For foam-plastic insulation, from ICC-ES.

1.4 DELIVERY, STORAGE, AND HANDLING

- A. Protect insulation materials from physical damage and from deterioration due to moisture, soiling, and other sources.
1. Store inside and in a dry location.
 2. Comply with manufacturer's written instructions for handling, storing, and protecting during installation.
- B. Protect foam-plastic board insulation as follows:
1. Do not expose to sunlight except to necessary extent for period of installation and concealment.

**NISQUALLY STATE PARK
NEW FULL SERVICE PARK – PHASE 2**

2. Protect against ignition at all times. Do not deliver foam-plastic board materials to Project site until just before installation time.
3. Quickly complete installation and concealment of foam-plastic board insulation in each area of construction.

PART 2 - PRODUCTS

2.1 PERFORMANCE CRITERIA

- A. Fire-Resistance Ratings: Comply with ASTM E119 or UL 263; testing by a qualified testing agency. Identify products with appropriate markings of applicable testing agency.
 1. Indicate design designations from UL's "Fire Resistance Directory" or from listings of another qualified testing agency.
- B. Fire Propagation Characteristics: Passes NFPA 285 testing as part of an approved assembly.
- C. Labeling: Provide identification of mark indicating R-value of each piece of insulation 12 inches and wider in width.

2.2 EXTRUDED POLYSTYRENE FOAM-PLASTIC BOARD INSULATION

- A. Extruded polystyrene boards in this Article are also called "XPS boards." Roman numeral designators in ASTM C578 are assigned in a fixed random sequence, and their numeric order does not reflect increasing strength or other characteristics.
- B. Extruded-Polystyrene Board (XPS.INSUL): ASTM C578, unfaced, of type and minimum compressive strength indicated below.
 1. Products: Subject to compliance with requirements, provide one of the following:
 - a. DiversiFoam Products: CertiFoam.
 - b. Dow Chemical Company: STYROFOAM Brand XPS.
 - c. Kingspan Insulation Limited: GreenGuard XPS Insulation Board.
 - d. Owens Corning Insulating Systems, LLC: Foamular Extruded Polystyrene Insulation.
 - e. Approved substitution.
 2. Thickness: As indicated on Drawings.
 3. Board Edges: Ship-lap or channel, unless indicated otherwise.
 4. Minimum Compressive Strength:
 - a. XPS.INSUL-1 (Type X): 1.30 pcf density, 15 psi.
 - b. XPS.INSUL-3 (Type VI): 1.80 pcf density, 40 psi.
 5. R-Value: 4.20 per inch.
 6. Surface-Burning Characteristics: Comply with ASTM E84.
 - a. Flame-Spread Index: 25 or less.

**NISQUALLY STATE PARK
NEW FULL SERVICE PARK – PHASE 2**

- b. Smoke-Developed Index: 450 or less.
- 7. Fire Propagation Characteristics: Passes NFPA 285 testing as part of an approved assembly.
- 8. Applications:
 - a. XPS.INSUL-1:
 - 1) Above grade where indicated.
 - b. XPS.INSUL-3:
 - 1) Below grade at cast-in-place concrete foundation walls.
 - 2) Below grade slab edges.

2.3 POLYISOCYANURATE FOAM-PLASTIC BOARD INSULATION

- A. Polyisocyanurate Board Insulation, General (PB.INSUL): ASTM C1289, Type, Class, and Grade as indicated.
 - 1. Foam: Closed cell polyisocyanurate foam, non-halogenated (CFC- and HCFC-free).
 - 2. Board Edges: Square.
 - 3. Long Term Thermal Resistance (LTTR) Values: 5.7 per inch.
 - 4. Temperature Change (Range): Minus 40 deg F to 250 deg F.
 - 5. Surface-Burning Characteristics: Comply with ASTM E84.
 - a. Flame Spread: 75 or less.
 - b. Smoke Developed: 450 or less.
 - 6. Fire Propagation Characteristics: Passes NFPA 285 testing as part of an approved assembly.
- B. Polyisocyanurate Board Insulation, Coated Glass Faced (PB.INSUL-1): ASTM C1289, Type II, Class 2, Grade 2.
 - 1. Manufacturers: Subject to compliance with requirements, provide one of the following:
 - a. Atlas Roofing Corporation: ACFoam III NH.
 - b. Carlisle SynTec Incorporated: SecureShield NH Polyiso.
 - c. Firestone Building Products: ISOGARD CG.
 - d. Hunter Panels: H-Shield CG.
 - e. Johns Manville: Flat & Tapered ENERGY 3 CGF.
 - f. Sika Corporation: Sarnatherm CG.
 - g. Versico Incorporated: SecurShield NH Polyiso.
 - h. Approved substitution.
 - 2. Physical Properties:
 - a. Facings: Inorganic coated glass facer both sides.
 - b. Board Edges: Square.
 - c. Long Term Thermal Resistance (LTTR) Values: 5.7 per inch.
 - d. Water Absorption After 2 Hour Immersion: ASTM C209: Less than 1 percent.

**NISQUALLY STATE PARK
NEW FULL SERVICE PARK – PHASE 2**

- e. Water Vapor Permeance: ASTM E96; less than 1.5 perms.
- f. Temperature Change (Range): Minus 40 deg F to 250 deg F.
- g. Surface-Burning Characteristics: Comply with ASTM E84.
 - 1) Flame Spread: 75 or less.
 - 2) Smoke Developed: 450 or less.
- h. Compressive Strength: ASTM C1289; 20 psi.
- i. Size: 48 by 48 inches.
- j. Thickness: 2 equal layers as required to meet thermal requirements.
- k. Sustainability: Red List Free.

- 3. Applications: Roof insulation at standing-seam metal roofing.

2.4 GLASS-FIBER BLANKET INSULATION

A. Glass-Fiber Blanket Insulation, General:

- 1. Thermal Values: Provide insulation at the following locations with minimum R-Value of 4.5 per inch at 32 degrees F.
 - a. Cavities of 5-1/2 inches: R-20.
 - b. Cavities of 6-1/4 inches: R-19.
 - c. Cavities of 7-1/4 inches: R-25.
- 2. Surface-Burning Characteristics: Comply with ASTM E84.
 - a. Flame Spread: 25.
 - b. Smoke Developed:
 - 1) Unfaced 50.
 - 2) Faced: 0.
- 3. Combustibility: Noncombustible when tested according to ASTM E136.
- 4. Thermal Resistivity: 4.3 deg F x h x sq. ft./Btu x in. at 75 deg F.
- 5. Fire Propagation Characteristics: Passes NFPA 285 testing as part of an approved assembly.

B. Glass-Fiber Blanket, Unfaced: ASTM C665, Type I.

- 1. Manufacturers: Subject to compliance with requirements, provide products by one of the following:
 - a. CertainTeed Corporation: CertaPro Sustainable Insulation.
 - b. Johns Manville: Formaldehyde-free Unfaced Fiberglass.
 - c. Knauf Insulation: EcoBatt Insulation.
 - d. Owens Corning Insulating Systems, LLC: EcoTouch PINK Fiberglass Insulation.
 - e. Approved substitution.
- 2. Applications: Exterior stud framed walls.

**NISQUALLY STATE PARK
NEW FULL SERVICE PARK – PHASE 2**

2.5 VAPOR RETARDERS

- A. Sheet Vapor Retarder (SVR): Mechanically-fastened polyamide film vapor retarder for use with unfaced, vapor-permeable glass fiber and mineral wool insulation in wall and ceiling cavities.
 - 1. Product: Subject to compliance with requirements, provide the following:
 - a. CertainTeed, Saint-Gobain: MemBrain Continuous Air Barrier & Smart Vapor Retarder.
 - b. Approved substitution.
 - 2. Thickness: 2 mil.
 - 3. Water Vapor Permeance: ASTM E96.
 - a. Dry Cup Method: 1.0 perms.
 - b. Wet Cup Method: 10.0 perms.
 - 4. Surface Burning Characteristics: Class A ratings according to ASTM E84:
 - a. Flame-Spread Index: 20 or less.
 - b. Smoke-Developed Index: 55 or less.

- B. Self-Adhering-Sheet Vapor Retarder (SA.SVR): ASTM D1970, polyethylene film laminated to layer of rubberized asphalt adhesive, cold applied, with slip-resisting surface and release paper backing. Provide primer when recommended by vapor retarder manufacturer.
 - 1. Products: Subject to compliance with requirements, provide one of the following:
 - a. Carlisle SynTec Incorporated: VapAir Seal 725TR Air & Vapor Barrier.
 - b. Firestone Building Products: V-Force Vapor Barrier Membrane.
 - c. Johns Manville: JM Vapor Barrier SA.
 - d. Versico Incorporated: VapAir Seal 725TR Air & Vapor Barrier.
 - e. Approved substitution.
 - 2. Thickness: Minimum 30 mils, nominal.
 - 3. Permeance Rating: ASTM E2178; maximum of 0.1 perm.
 - 4. Peel Adhesion: ASTM D903; minimum 5.0 lbf/in.
 - 5. Application: Roof cover boards at standing seam metal roofing.

2.6 INSULATION FOR MISCELLANEOUS VOIDS

- A. Glass-Fiber Insulation: ASTM C764, Type II, loose fill; with maximum flame-spread and smoke-developed indexes of 5, per ASTM E84.

- B. Spray Foam Sealant (SF.SLNT-1): Single component, low-pressure, closed cell, polyurethane foam used as an air barrier foam.
 - 1. Products: Subject to compliance with requirements, provide one of the following:
 - a. DAP Products, Inc.: Draftstop 812.

**NISQUALLY STATE PARK
NEW FULL SERVICE PARK – PHASE 2**

- b. Dow Chemical Company: Great Stuff Pro.
- c. Franklin International: Titebond WeatherMaster X-Treme Window & Door.
- d. Henkel Corporation: OSI QUAD Foam Window & Door Installation Foam.
- e. Hilti, Inc.: CF 812 Window and Door Pro.
- f. Soudal: SoudaFoam Door & Window.
- g. Tremco, Inc.: ExoAir FlexFoam.
- h. Approved substitution.

2. Applications:

- a. Sealing perimeters of window and door rough openings in exterior walls.

2.7 ACCESSORIES

- A. Vapor-Retarder Staples: Galvanized construction grade staples of type recommended by vapor-retarder manufacturer for installing vapor-retarder.
- B. Adhesive for Bonding Insulation: Product compatible with insulation and air and water barrier materials, and with demonstrated capability to bond insulation securely to substrates without damaging insulation and substrates.

PART 3 - EXECUTION

3.1 PREPARATION

- A. Clean substrates of substances that are harmful to insulation, including removing projections capable of puncturing insulation or vapor retarders, or that interfere with insulation attachment.

3.2 INSTALLATION, GENERAL

- A. Comply with insulation manufacturer's written instructions applicable to products and applications.
- B. Install insulation that is undamaged, dry, and unsoiled and that has not been left exposed to ice, rain, or snow at any time.
- C. Extend insulation to envelop entire area to be insulated. Fit tightly around obstructions and fill voids with insulation. Remove projections that interfere with placement.
- D. Provide sizes to fit applications and selected from manufacturer's standard thicknesses, widths, and lengths. Apply single layer of insulation units unless multiple layers are otherwise shown or required to make up total thickness or to achieve R-value.

3.3 INSTALLATION OF SLAB INSULATION

- A. On vertical slab edge and foundation surfaces, set insulation units using manufacturer's recommended adhesive according to manufacturer's written instructions. Stagger end joints and tightly butt panel edges in both directions for tight fit.

**NISQUALLY STATE PARK
NEW FULL SERVICE PARK – PHASE 2**

1. If not otherwise indicated, extend insulation a minimum of 36 inches below exterior grade line.
- B. On horizontal surfaces, loosely lay insulation units according to manufacturer's written instructions. Stagger end joints and tightly butt panel edges in both directions for tight fit.
1. If not otherwise indicated, extend insulation a minimum of 36 inches in from exterior walls.
- 3.4 INSTALLATION OF FOUNDATION WALL INSULATION
- A. Stagger end joints and tightly butt panel edges in both directions for tight fit.
- B. Install foundation insulation using one of the following methods:
1. Anchor Installation: Install board insulation on concrete substrates by adhesively attached, spindle-type insulation anchors as follows:
 - a. Fasten insulation anchors to concrete substrates with insulation anchor adhesive according to anchor manufacturer's written instructions. Space anchors according to insulation manufacturer's written instructions for insulation type, thickness, and application.
 - b. Apply insulation standoffs to each spindle to create cavity width indicated on Drawings between concrete substrate and insulation.
 - c. After adhesive has dried, install board insulation by pressing insulation into position over spindles and securing it tightly in place with insulation-retaining washers, taking care not to compress insulation.
 - d. Where insulation will not be covered by other building materials, apply capped washers to tips of spindles.
 2. Adhesive Installation: Install with adhesive or press into tacky waterproofing or dampproofing according to manufacturer's written instructions.
- 3.5 INSTALLATION OF FRAMED CONSTRUCTION INSULATION
- A. Blanket Insulation: Install in cavities formed by framing members according to the following requirements:
1. Use insulation widths and lengths that fill the cavities formed by framing members. If more than 1 length is required to fill cavities, provide lengths that will produce a snug fit between ends.
 2. Place insulation in cavities formed by framing members to produce a friction fit between edges of insulation and adjoining framing members.
 3. Maintain 3 inch clearance of insulation around recessed lighting fixtures not rated for or protected from contact with insulation.
 4. For wood-framed construction, install blankets according to ASTM C1320 and as follows:
 - a. With faced blankets having stapling flanges, lap blanket flange over flange of adjacent blanket to maintain continuity of vapor retarder once finish material is installed over it.

**NISQUALLY STATE PARK
NEW FULL SERVICE PARK – PHASE 2**

- B. Miscellaneous Voids: Install insulation in miscellaneous voids and cavity spaces where required to prevent gaps in insulation using the following materials:
 - 1. Glass-Fiber Insulation: Compact to approximately 40 percent of normal maximum volume equaling a density of approximately 2.5 pcf.
 - 2. Spray Foam Sealant: Apply according to manufacturer's written instructions.

3.6 INSTALLATION OF VAPOR RETARDERS ON FRAMING

- A. Place vapor retarders on warm side of framing unless indicated otherwise on Drawings.
- B. Extend vapor retarders to extremities of areas to protect from vapor transmission.
 - 1. Secure vapor retarders in place on metal studs with adhesive or tape as recommended by manufacturer.
 - 2. Secure vapor retarder in place on wood studs with staples, adhesive, tape, or other anchorage system as recommended by manufacturer.
 - 3. Extend vapor retarders to cover miscellaneous voids in insulated substrates, including insulation-filled miscellaneous voids.
- C. Seal vertical joints in vapor retarders over framing by lapping no fewer than 2 studs and sealing with vapor-retarder tape according to vapor-retarder manufacturer's written instructions.
 - 1. Locate joints over framing members or other solid substrates.
- D. Seal joints caused by pipes, conduits, electrical boxes, and similar items penetrating vapor retarders with vapor-retarder tape to create an airtight seal between penetrating objects and vapor retarders.
- E. Repair tears or punctures in vapor retarders immediately before concealment by other Work.
 - 1. Cover with vapor-retarder tape or another layer of vapor retarder.

3.7 INSTALLATION OF VAPOR-RETARDER ON ROOF

- A. Self-Adhering-Sheet Vapor Retarder: Prime roof substrate board if required by manufacturer. Install self-adhering-sheet vapor retarder over area to receive vapor retarder, side and end lapping each sheet a minimum of 3-1/2 and 6 inches, respectively.
 - 1. Extend vertically up parapet walls and projections to a minimum height equal to height of insulation and cover board.
 - 2. Seal laps by rolling.
- B. Completely seal vapor retarder at terminations, obstructions, and penetrations to prevent air movement into roofing system.

**NISQUALLY STATE PARK
NEW FULL SERVICE PARK – PHASE 2**

3.8 PROTECTION

- A. Protect installed insulation from damage due to harmful weather exposures, physical abuse, and other causes.
- B. Provide temporary coverings or enclosures where insulation is subject to abuse and cannot be concealed and protected by permanent construction immediately after installation.
- C. Protect vapor retarders from damage until concealed by permanent construction.

END OF SECTION

**NISQUALLY STATE PARK
NEW FULL SERVICE PARK – PHASE 2**

SECTION 072715 – NONBITUMINOUS SELF-ADHERING SHEET AIR BARRIERS

PART 1 - GENERAL

1.1 SUMMARY

A. Section Includes:

1. Self-adhering, vapor-permeable, nonbituminous sheet air barriers.

1.2 ADMINISTRATIVE REQUIREMENTS

A. Preinstallation Meetings: Conduct meeting at Project site.

1. Review air-barrier requirements and installation, special details, mockups, air-leakage and bond testing, air-barrier protection, and work scheduling that covers air barriers.

1.3 ACTION SUBMITTALS

A. Product Data: For self-adhering air barrier.

1. Include manufacturer's written instructions for evaluating, preparing, and treating each substrate; technical data; and tested physical and performance properties of products.

B. Shop Drawings: For air-barrier assemblies.

1. Show locations and extent of air-barrier materials, accessories, and assemblies specific to Project conditions.
2. Include details for substrate joints and cracks, counterflashing strips, penetrations, inside and outside corners, terminations, and tie-ins with adjoining construction.
3. Include details of interfaces with other materials that form part of air barrier.

1.4 INFORMATIONAL SUBMITTALS

A. Qualification Data: For Installer. Include list of ABAA-certified installers and supervisors employed by Installer, who work on Project.

B. Product Certificates: From air-barrier manufacturer, certifying compatibility of air barriers and accessory materials with Project materials that connect to or that come in contact with air barrier.

C. Product Test Reports: For each air-barrier assembly, for tests performed by a qualified testing agency.

**NISQUALLY STATE PARK
NEW FULL SERVICE PARK – PHASE 2**

1.5 QUALITY ASSURANCE

- A. Installer Qualifications: An entity that employs installers and supervisors who are trained and approved by manufacturer with a minimum of 5 years of experience installing systems similar in scope to this Project.
- B. Mockups:
 - 1. Build integrated mockups of exterior wall assembly as indicated on Drawings, or a minimum of 100 sq. ft., incorporating backup wall construction, external cladding, window, storefront, door frame and sill, insulation, ties and other penetrations, and flashing to demonstrate surface preparation, crack and joint treatment, application of air barriers, and sealing of gaps, terminations, and penetrations of air-barrier assembly.
 - a. Coordinate construction of mockups to permit inspection and testing of air barrier before external insulation and cladding are installed.
 - b. Include junction with roofing membrane, building corner condition, and foundation wall intersection.
 - c. If Architect determines mockups do not comply with requirements, reconstruct mockups and apply air barrier until mockups are approved.
 - 2. Approval of mockups does not constitute approval of deviations from Contract Documents contained in mockups unless Architect specifically approves such deviations in writing.
 - 3. Subject to compliance with requirements, approved mockups may become part of completed Work if undisturbed at time of Substantial Completion.

1.6 PRECONSTRUCTION TESTING

- A. Preconstruction Testing Service: Owner may engage a qualified testing agency to perform preconstruction testing on field mockups.
- B. Mockup Testing: Air-barrier assemblies shall comply with performance requirements indicated, as evidenced by reports based on mockup testing by a qualified testing agency.
 - 1. Air-Leakage-Volume Testing: Mockups will be tested for air-leakage rate according to ASTM E783 or ASTM E2357.
 - 2. Adhesion Testing: Mockups will be tested for required air-barrier adhesion to substrate according to ASTM D4541.
 - 3. Notify Architect 7 days in advance of dates and times when mockups will be tested.

1.7 DELIVERY, STORAGE, AND HANDLING

- A. Remove and replace liquid materials that cannot be applied within their stated shelf life.
- B. Protect stored materials from direct sunlight.

**NISQUALLY STATE PARK
NEW FULL SERVICE PARK – PHASE 2**

1.8 FIELD CONDITIONS

- A. Environmental Limitations: Apply air barrier within range of ambient and substrate temperatures recommended in writing by air-barrier manufacturer.
 - 1. Protect substrates from environmental conditions that affect air-barrier performance.
 - 2. Do not apply air barrier to a damp or wet substrate or during snow, rain, fog, or mist.

PART 2 - PRODUCTS

2.1 MATERIALS

- A. Source Limitations: Obtain primary air-barrier materials and air-barrier accessories from single source from single manufacturer.

2.2 PERFORMANCE CRITERIA

- A. Air-Barrier Performance:
 - 1. Air-barrier assembly and seals with adjacent construction shall be capable of performing as a continuous air barrier and as a liquid-water drainage plane flashed to discharge to exterior incidental condensation or water penetration.
 - 2. Air-barrier assemblies shall be capable of accommodating substrate movement and of sealing substrate expansion and control joints, construction material changes, penetrations, and transitions at perimeter conditions without deterioration and air leakage exceeding specified limits.
- B. Air-Barrier Assembly Air Leakage: Maximum 0.04 cfm/sq. ft. of surface area at 1.57 lbf/sq. ft., when tested according to ASTM E2357.

2.3 NONBITUMINOUS SHEET AIR BARRIER

- A. Vapor-Permeable Nonbituminous Sheet (SAAB.VP-1): Self-adhering sheet consisting of breathable carrier film or fabric and an adhesive with release liner on adhesive side.
 - 1. Basis-of-Design Product: Subject to compliance with requirements, provide the following manufacturers:
 - a. Henry Company: Blueskin VP160.
 - b. SIGA Cover Inc.: SIGA Majvest 500 SA.
 - c. Tremco Incorporated: ExoAir 210AT.
 - d. VaproShield LLC: WrapShield SA Self-Adhered Water Resistive Barrier.
 - e. W. R. Meadows, Inc.: Air-Shield SMP.
 - f. Approved substitution.
 - 2. Thickness: Minimum 20 mils.
 - 3. Physical and Performance Properties:

**NISQUALLY STATE PARK
NEW FULL SERVICE PARK – PHASE 2**

- a. Air Permeance: ASTM E2178; maximum 0.004 cfm/sq. ft. of surface area at 1.57 lbf/sq. ft. pressure difference.
- b. Puncture Resistance: ASTM E154; minimum 40 lbf.
- c. Vapor Permeance: ASTM E96, Desiccant Method (Procedure A); minimum 15 perms.
- d. Adhesion to Substrate: ASTM D4541 as modified by ABAA ; minimum 16 lbf/sq. in.
- e. Fire Propagation Characteristics: Passes NFPA 285 testing as part of an approved assembly.
- f. UV Resistance: Not less than 150 days according to manufacturer's written instructions.

2.4 AUXILIARY MATERIALS

- A. Provide primers, transition strips, termination strips, joint sealants, counterflashing strips, flashing sheets and metal termination bars, termination mastic, substrate patching materials, adhesives, tapes, foam sealants, lap sealants, and other accessory materials that are recommended in writing by air-barrier manufacturer to produce a complete air-barrier assembly and that are compatible with primary air-barrier material and adjacent construction to which they may seal.
- B. Primer: Liquid waterborne primer recommended for substrate by air-barrier material manufacturer.
- C. Flexible Flashings: Refer to Section 076500 – Flexible Flashing for the following:
 - 1. LM.FLSHG-1: Stainless steel fabric flashing.
 - 2. LM.FLSHG-3: Aluminum-faced, modified bituminous transition membrane.
 - 3. SA.FLSHG-2: Rubberized-asphalt transition membrane.
 - 4. SA.FLSHG-3: Rubberized-asphalt thru-wall flashing.
 - 5. SA.FLSHG-6: Self-adhering, high temperature flashing.

PART 3 - EXECUTION

3.1 EXAMINATION

- A. Examine substrates, areas, and conditions, with Installer present, for compliance with requirements and other conditions affecting performance of Work. Verify the following:
 - 1. Substrates are sound and free of oil, grease, dirt, excess mortar, or other contaminants.
 - 2. Substrates have cured and aged for minimum time recommended in writing by air-barrier manufacturer.
 - 3. Substrates are visibly dry and free of moisture.
- B. Proceed with installation only after unsatisfactory conditions have been corrected.

3.2 SURFACE PREPARATION

- A. Clean, prepare, treat, fill, and seal substrate and joints and cracks in substrate according to manufacturer's written instructions and details. Provide clean, dust-free, and dry substrate for air-barrier application.

**NISQUALLY STATE PARK
NEW FULL SERVICE PARK – PHASE 2**

- B. Mask off adjoining surfaces not covered by air barrier to prevent spillage and overspray affecting other construction.
- C. At changes in substrate plane, apply sealant or termination mastic beads at sharp corners and edges to form a smooth transition from one plane to another.
- D. Cover gaps in substrate plane and form a smooth transition from one substrate plane to another with stainless-steel sheet mechanically fastened to structural framing to provide continuous support for air barrier.

3.3 INSTALLATION

- A. Install materials according to air-barrier manufacturer's written instructions and details to form a seal with adjacent construction and ensure continuity of air and water barrier.
 - 1. Unless manufacturer recommends in writing against priming, apply primer to substrates at required rate and allow it to dry.
- B. Prepare, treat, and seal inside and outside corners and vertical and horizontal surfaces at terminations and penetrations with termination mastic.
- C. Apply primer to substrates at required rate and allow it to dry. Limit priming to areas that will be covered by air-barrier sheet on same day. Reprime areas exposed for more than 24 hours.
- D. Apply and firmly adhere air-barrier sheets over area to receive air barrier.
 - 1. Accurately align sheets and maintain uniform 2-1/2 inch minimum lap widths and end laps.
 - 2. Overlap and seal seams, and stagger end laps to ensure airtight installation.
 - 3. Apply sheets in a shingled manner to shed water.
 - 4. Roll sheets firmly to enhance adhesion to substrate.
- E. Apply continuous air-barrier sheets over accessory strips bridging substrate cracks, and construction and contraction joints.
- F. Seal top of through-wall flashings to air-barrier sheet with an additional 6 inchwide, transition strip.
- G. Seal exposed edges of sheet at seams, cuts, penetrations, and terminations not concealed by metal counterflashings or ending in reglets with termination mastic.
- H. Install air-barrier sheet and accessory materials to form a seal with adjacent construction and to maintain a continuous air barrier.
 - 1. Coordinate air-barrier installation with installation of roofing membrane and base flashing to ensure continuity of air barrier with roofing membrane.
 - 2. Install transition strip on roofing membrane or base flashing so that a minimum of 3 inches of coverage is achieved over each substrate.
- I. Connect and seal exterior wall air-barrier sheet continuously to exterior glazing and window systems, exterior door framing, and other construction used in exterior wall openings, using accessory materials.

**NISQUALLY STATE PARK
NEW FULL SERVICE PARK – PHASE 2**

- J. At end of each working day, seal top edge of air-barrier material to substrate with termination mastic.
- K. Apply joint sealants forming part of air-barrier assembly within manufacturer's recommended application temperature ranges. Consult manufacturer when sealant cannot be applied within these temperature ranges.
- L. Wall Openings: Prime concealed, perimeter frame surfaces of windows and doors. Apply transition strip so that a minimum of 3 inches of coverage is achieved over each substrate. Maintain 3 inches of contact over firm bearing to perimeter frames, with not less than 1 inch of full contact.
 - 1. Transition Strip: Roll firmly to enhance adhesion.
- M. Fill gaps in perimeter frame surfaces of windows, doors, and miscellaneous penetrations of air-barrier material with foam sealant.
- N. Do not cover air barrier until it has been tested and inspected by testing agency.

3.4 REPAIR

- A. Repair punctures, voids, and deficient lapped seams in air barrier.
 - 1. Slit and flatten fishmouths and blisters.
 - 2. Patch with air-barrier sheet extending 6 inches beyond repaired areas in all directions.
- B. Correct deficiencies in or remove air barrier that does not comply with requirements; repair substrates and reapply air-barrier components.

3.5 FIELD QUALITY CONTROL

- A. ABAA Quality Assurance Program: Perform examinations, preparation, installation, testing, and inspections under ABAA's Quality Assurance Program.
- B. Testing Agency: Owner will engage a qualified testing agency to perform tests and inspections.
- C. Tests: As determined by testing agency from among the following tests:
 - 1. Air-Leakage-Volume Testing: Test air-barrier assemblies for air-leakage rate according to ASTM E783 or ASTM E2357.
 - 2. Adhesion Testing: Test air-barrier assemblies for required adhesion to substrate according to ASTM D4541 for each 600 sq. ft. of installed air barrier or part thereof.
- D. Air barriers will be considered defective if they do not pass tests and inspections.
 - 1. Apply additional air-barrier material, according to manufacturer's written instructions, where inspection results indicate insufficient thickness.
 - 2. Remove and replace deficient air-barrier components for retesting as specified above.
- E. Repair damage to air barriers caused by testing; follow manufacturer's written instructions.

**NISQUALLY STATE PARK
NEW FULL SERVICE PARK – PHASE 2**

F. Prepare test and inspection reports.

3.6 CLEANING AND PROTECTION

- A. Clean spills, stains, and soiling from construction that would be exposed in completed Work, using cleaning agents and procedures recommended in writing by manufacturer of affected construction.
- B. Protect air-barrier system from damage during application and remainder of construction period, according to manufacturer's written instructions.
 - 1. Protect air barrier from exposure to UV light and harmful weather exposure as recommended in writing by manufacturer. If exposed to these conditions for longer than recommended, remove and replace air barrier or install additional, full-thickness, air-barrier application after repairing and preparing the overexposed materials according to air-barrier manufacturer's written instructions.
 - 2. Protect air barrier from contact with incompatible materials and sealants not approved by air-barrier manufacturer.

END OF SECTION

**NISQUALLY STATE PARK
NEW FULL SERVICE PARK – PHASE 2**

SECTION 073013 – ROOFING UNDERLAYMENTS

PART 1 - GENERAL

1.1 SUMMARY

A. Section Includes:

1. Self-adhering sheet underlayment.

1.2 ACTION SUBMITTALS

A. Product Data: For each product indicated.

B. Samples for Verification: 12 inch square Samples for the following products, to verify color selected:

1. Self-adhering sheet underlayment.

1.3 INFORMATIONAL SUBMITTALS

A. Qualification Data: For Installer.

B. Product Test Reports: For each type of underlayment product indicated, for tests performed by manufacturer and witnessed by a qualified testing agency.

C. Sample Warranty: For manufacturer's materials warranty.

1.4 QUALITY ASSURANCE

A. Fire-Test-Response Characteristics: Provide underlayment and related roofing materials with fire-test-response characteristics indicated, as determined by testing identical products per test method below by UL or another testing and inspecting agency acceptable to authorities having jurisdiction. Identify materials with appropriate markings of applicable testing and inspecting agency.

1. Exterior Fire-Test Exposure: Class A; ASTM E108 or UL 790, for application and roof slopes indicated.

1.5 DELIVERY, STORAGE, AND HANDLING

A. Store underlayment materials in a dry, well-ventilated location protected from weather, sunlight, and moisture in accordance with manufacturer's written instructions.

B. Store underlayment rolls on end, on pallets or other raised surfaces. Do not double-stack rolls.

**NISQUALLY STATE PARK
NEW FULL SERVICE PARK – PHASE 2**

- C. Protect unused roofing materials from weather, sunlight, and moisture when left overnight or when roofing Work is not in progress.
- D. Handle, store, and place underlayment materials in a manner to prevent damage to roof deck or structural supporting members.

1.6 FIELD CONDITIONS

- A. Environmental Limitations: Proceed with installation only when existing and forecasted weather conditions permit product installation and related Work to be performed in accordance with manufacturer's written instructions and warranty requirements.
 - 1. Install self-adhering, polymer-modified bitumen sheet underlayment within range of ambient and substrate temperatures recommended in writing by manufacturer.

1.7 WARRANTY

- A. Manufacturer's Warranty: Manufacturer agrees to repair or replace underlayment that fails within specified warranty period by allowing water to penetrate roofing substrates to which it is applied due to decomposition beneath primary roof covering under which it is installed.
 - 1. Warranty Periods: 20 years from date of Substantial Completion.

PART 2 - PRODUCTS

2.1 UNDERLAYMENT MATERIALS

- A. Source Limitations: Obtain underlayments through one source from a single manufacturer.
- B. Self-Adhering, High Temperature Underlayment: Self-adhering, cold-applied, sheet underlayment consisting of slip-resistant, polyethylene-film top surface laminated to a layer of SBS-modified asphalt adhesive, with release-paper backing. Provide primer when recommended by underlayment manufacturer.
 - 1. Products: Furnished or recommended by metal roofing manufacturer complying with the following physical properties:
 - a. Thickness: Minimum of 40 mils.
 - b. Service Temperature: Minimum 230 deg F.
 - c. Thermal Stability: ASTM D1970, stable after testing at 240 deg F.
 - d. Low-Temperature Flexibility: ASTM D1970; passes after testing at minus 20 deg F.
 - e. Vapor Permeance: 0.01 perms; ASTM E96.
 - f. Minimum Roof Slope: Do not install on slopes less than 1:12.
 - g. Allowable UV Exposure Time: Not less than 90 days.

**NISQUALLY STATE PARK
NEW FULL SERVICE PARK – PHASE 2**

PART 3 - EXECUTION

3.1 EXAMINATION

- A. Examine substrates, areas, and conditions, with Installer present, for compliance with requirements for installation tolerances and other conditions affecting performance of Work.
 - 1. Examine roof sheathing to verify that sheathing joints are supported by framing and blocking and that installation is within flatness tolerances.
 - 2. Verify that substrate is sound, dry, smooth, clean, sloped for drainage, and completely anchored; and that provision has been made for flashings and penetrations.
- B. Prepare written report, endorsed by Installer, listing conditions detrimental to performance of Work.
- C. Proceed with installation only after unsatisfactory conditions have been corrected.

3.2 INSTALLATION OF UNDERLAYMENT, METAL ROOF PANELS

- A. Comply with metal roofing and underlayment manufacturers' written installation instructions applicable to products and applications indicated unless more stringent requirements apply. Complete underlayment installation ready to receive Work of Section 074113.16 – Standing Seam Metal Roof Panels.
- B. Self-Adhering, High Temperature Underlayment:
 - 1. Install wrinkle free, in shingle fashion to shed water.
 - a. Lap sides not less than 4 inches.
 - b. Lap ends not less than 6 inches, staggered 24 inches between succeeding courses.
 - c. Overlap side edges not less than 3-1/2 inches.
 - d. Extend underlayment into gutter trough.
 - e. Roll laps with roller.
 - 2. Application: Over entire roof area receiving metal roofing panels.

3.3 INSTALLATION OF UNDERLAYMENT, SHEET METAL FLASHING

- A. Comply with sheet metal flashing and underlayment manufacturers' written installation instructions applicable to products and applications indicated unless more stringent requirements apply. Complete underlayment installation ready to receive Work of Section 076200 – Sheet Metal Flashing and Trim.

**NISQUALLY STATE PARK
NEW FULL SERVICE PARK – PHASE 2**

B. Self-Adhering, High Temperature Underlayment:

1. Apply primer if required by underlayment manufacturer.
2. Install wrinkle free, in shingle fashion to shed water.
 - a. Lap ends not less than 6 inches, staggered 24 inches between succeeding courses.
 - b. Overlap side edges not less than 3-1/2 inches.
 - c. Roll laps and edges with roller.
3. Application: Underneath parapet caps, coping, and other sheet metal flashing systems where indicated on Drawings.

3.4 PROTECTION

- A. Protect installed underlayments until installation of roof covering and sheet metal flashing and trim.

END OF SECTION

**NISQUALLY STATE PARK
NEW FULL SERVICE PARK – PHASE 2**

SECTION 074113.16 – STANDING-SEAM METAL ROOF PANELS

PART 1 - GENERAL

1.1 SUMMARY

A. Section Includes:

1. Standing-seam metal roof panels.

B. Related Requirements:

1. Section 061600 – Sheathing, for substrate and cover boards.
2. Section 072100 – Thermal Insulation, for vapor retarder and insulation.
3. Section 073013 – Roofing Underlayments.
4. Section 136000 - Kiosks

1.2 ADMINISTRATIVE REQUIREMENTS

A. Coordination:

1. Coordinate sizes and locations of roof curbs, equipment supports, and roof penetrations with actual equipment provided.
2. Coordinate metal panel installation with rain drainage Work, flashing, trim, construction of soffits, and other adjoining Work to provide a leakproof, secure, and noncorrosive installation.

B. Preinstallation Meetings: Conduct meeting at Project site.

1. Meet with Owner, Architect, Owner's insurer if applicable, metal panel Installer, metal panel manufacturer's representative, structural-support Installer, and installers whose Work interfaces with or affects metal panels, including installers of roof accessories and roof-mounted equipment.
2. Review and finalize construction schedule and verify availability of materials, Installer's personnel, equipment, and facilities needed to make progress and avoid delays.
3. Review methods and procedures related to metal panel installation, including manufacturer's written instructions.
4. Examine support conditions for compliance with requirements, including alignment between and attachment to structural members.
5. Review structural loading limitations of deck during and after roofing.
6. Review flashings, special details, drainage, penetrations, equipment curbs, and condition of other construction that affect metal panels.
7. Review governing regulations and requirements for insurance, certificates, and tests and inspections if applicable.
8. Review temporary protection requirements for metal panel systems during and after installation.
9. Review procedures for repair of metal panels damaged after installation.

**NISQUALLY STATE PARK
NEW FULL SERVICE PARK – PHASE 2**

10. Document proceedings, including corrective measures and actions required, and furnish copy of record to each participant.

1.3 ACTION SUBMITTALS

A. Product Data: For each type of product.

1. Include construction details, material descriptions, dimensions of individual components and profiles, and finishes for each type of panel and accessory.

B. Shop Drawings:

1. Include fabrication and installation layouts of metal panels; details of edge conditions, joints, panel profiles, corners, anchorages, attachment system, trim, flashings, closures, and accessories; and special details.
2. Accessories: Include details of the flashing, trim, and anchorage systems, at a scale of not less than 1-1/2 inches per 12 inches.
3. Submit Shop Drawings that have been engineered and certified by professional engineer licensed in the State in which Project is located.

- a. Include seal and signature of professional engineer on Shop Drawings.

C. Samples for Verification: For each type of exposed finish required, prepared on Samples of size indicated below:

1. Metal Panels: 12 inches long by actual panel width. Include fasteners, closures, and other metal panel accessories.

D. Delegated-Design Submittal: For standing-seam metal roof panel systems, indicating compliance with performance and design criteria.

1. Include analysis data signed and sealed by qualified professional engineer responsible for their preparation.

1.4 INFORMATIONAL SUBMITTALS

A. Qualification Data:

1. For Installer.
2. For professional engineer indicating experience with providing delegated-design engineering services of the kind indicated.

- a. Include documentation that engineer is licensed in state in which Project is located.

B. Product Test Reports: For each product, for tests performed by a qualified testing agency.

**NISQUALLY STATE PARK
NEW FULL SERVICE PARK – PHASE 2**

1.5 CLOSEOUT SUBMITTALS

- A. Maintenance Data: For metal panels to include in maintenance manuals.

1.6 QUALITY ASSURANCE

- A. Manufacturer Qualifications: A firm that specializes in manufacturing specified metal roofing systems with a minimum of 10 years of documented experience.
- B. Installer Qualifications: An entity that employs installers and supervisors who are trained and approved by manufacturer with a minimum of 5 years of documented experience.
- C. Delegated-Design Engineer Qualifications: Professional engineer experienced in providing delegated-design engineering services of the kind indicated and is legally qualified to practice in state where Project is located.
- D. Mockups:
 - 1. Build mockup of typical roof area and eave, including fascia, as shown on Drawings; including attachments, underlayment, and accessories.
 - a. Mockup Size: 12 sq. ft. by full thickness.
 - b. Illustrate a complete assembly of each profile, proposed thickness, and finish.
 - c. Illustrate each type of exposed seam and seam termination.
 - 2. Approval of mockups does not constitute approval of deviations from Contract Documents contained in mockups unless Architect specifically approves such deviations in writing.
 - 3. Approved mockups may become part of completed Work if undisturbed at time of Substantial Completion.

1.7 DELIVERY, STORAGE, AND HANDLING

- A. Deliver components, metal panels, and other manufactured items so as not to be damaged or deformed. Package metal panels for protection during transportation and handling.
- B. Unload, store, and erect metal panels in a manner to prevent bending, warping, twisting, and surface damage.
- C. Stack metal panels horizontally on platforms or pallets, covered with suitable weathertight and ventilated covering. Store metal panels to ensure dryness, with positive slope for drainage of water. Do not store metal panels in contact with other materials that might cause staining, denting, or other surface damage.
- D. Retain strippable protective covering on metal panels during installation.

**NISQUALLY STATE PARK
NEW FULL SERVICE PARK – PHASE 2**

1.8 FIELD CONDITIONS

- A. Weather Limitations: Proceed with installation only when existing and forecasted weather conditions permit assembly of metal panels to be performed according to manufacturers' written instructions and warranty requirements.

1.9 WARRANTY

- A. Special Warranty: Manufacturer agrees to repair or replace components of metal panel systems that fail in materials or workmanship within specified warranty period.
 - 1. Failures include the following:
 - a. Structural failures including rupturing, cracking, or puncturing.
 - b. Deterioration of metals and other materials beyond normal weathering.
 - 2. Warranty Period: 2 years from date of Substantial Completion.
- B. Special Warranty on Panel Finishes: Manufacturer agrees to repair finish or replace metal panels that show evidence of deterioration of factory-applied finishes within specified warranty period.
 - 1. Exposed Panel Finish: Deterioration includes the following:
 - a. Color fading more than 5 Delta E units when tested according to ASTM D2244.
 - b. Chalking in excess of a No. 8 rating when tested according to ASTM D4214.
 - c. Cracking, checking, peeling, or failure of paint to adhere to bare metal.
 - 2. Finish Warranty Period: 20 years from date of Substantial Completion.

PART 2 - PRODUCTS

2.1 MANUFACTURERS

- A. Source Limitations: Obtain standing-seam metal roof panels from single source from single manufacturer.

2.2 PERFORMANCE CRITERIA

- A. Recycled Content: Postconsumer recycled content plus 1/2 of preconsumer recycled content not less than 50 percent.
- B. Delegated Design: Engage a qualified professional engineer to design standing-seam metal roof panel systems, including attachment to building construction.
- C. Structural Performance: Provide metal panel systems capable of withstanding effects of the following loads, based on testing according to ASTM E1592:

**NISQUALLY STATE PARK
NEW FULL SERVICE PARK – PHASE 2**

1. Wind Loads: As indicated on Drawings.
 2. Other Design Loads: As indicated on Drawings.
 3. Deflection Limits: For wind loads, no greater than 1/180 of span.
- D. Seismic Performance: Exterior metal panel systems, including anchors and connections, shall withstand effects of earthquake motions determined according to ASCE 7.
- E. Water Penetration under Static Pressure: With factory-applied continuous sealant, no water penetration when tested according to ASTM E1646 or ASTM E331 at the following test-pressure difference:
1. Test-Pressure Difference: 6.24 lbf/sq. ft.
- F. Wind-Uplift Resistance: Provide metal roof panel assemblies that comply with UL 580 for wind-uplift-resistance class indicated.
1. Uplift Rating: UL 90.
- G. Thermal Movements: Allow for thermal movements from ambient and surface temperature changes by preventing buckling, opening of joints, overstressing of components, failure of joint sealants, failure of connections, and other detrimental effects. Base calculations on surface temperatures of materials due to both solar heat gain and nighttime-sky heat loss.
1. Temperature Change (Range): 120 deg F, ambient; 180 deg F, material surfaces.

2.3 STANDING-SEAM METAL ROOF PANELS

- A. Factory-formed metal roof panels designed to be installed by lapping and interconnecting raised side edges of adjacent panels with joint type indicated and mechanically attaching panels to supports using concealed clips in side laps. Include clips, cleats, pressure plates, and accessories required for weathertight installation.
1. Steel Panel Systems: Unless more stringent requirements are indicated, comply with ASTM E1514.
- B. Vertical-Rib, Snap-Joint, Standing-Seam Metal Roof Panels: Structural metal panel formed with vertical ribs at panel edges and a flat pan between ribs; designed for sequential installation by mechanically attaching panels to supports using concealed clips located under 1 side of panels, engaging opposite edge of adjacent panels, and snapping panels together.
1. Products: Subject to compliance with requirements, provide one of the following:
 - a. AEP Span, a Division of ASC Profiles, Inc.: Design Span hp.
 - b. Bridger Steel, Inc.: 1.75" Tru Snap.
 - c. Metal Sales Manufacturing Corporation: Vertical Seam.
 - d. Morin; a Kingspan Group Company: SWL.
 - e. Petersen Aluminum Corp.: Snap-Clad.
 - f. Taylor Metal Inc.: Versa-Span SB.

**NISQUALLY STATE PARK
NEW FULL SERVICE PARK – PHASE 2**

2. Metallic-Coated Steel Sheet: Aluminum-zinc alloy-coated steel sheet complying with ASTM A792, Class AZ50 coating designation; structural quality. Prepainted by coil-coating process to comply with ASTM A755.
 - a. Nominal Thickness: 0.0232 inch.
 - b. Exterior Finish: 3-coat fluoropolymer.
 - c. Color: Match AEP Span Colonial Red.
3. Clips: 2-piece floating to accommodate thermal movement.
 - a. Material: 0.0250 inch thick, stainless-steel sheet or as required to meet performance requirements.
4. Panel Coverage: 12 inches unless indicated otherwise.
5. Panel Height: 1-3/4 inches.

2.4 UNDERLAYMENT MATERIALS

A. Roofing Underlayments:

1. Type 1 Underlayment as specified in Section 073013 – Roofing Underlayments.

2.5 AUXILIARY MATERIALS

- A. Roof Cover Boards: As specified in Section 061600 – Sheathing.
- B. Vapor Retarder: SA.SVR as specified in Section 072100 – Thermal Insulation.
- C. Insulation: PB.INSUL-1 as specified in Section 072100 – Thermal Insulation.

2.6 MISCELLANEOUS MATERIALS

- A. Miscellaneous Metal Subframing and Furring: ASTM C645; cold-formed, metallic-coated steel sheet, ASTM A653, G90 coating designation or ASTM A792, Class AZ50 coating designation unless otherwise indicated. Provide manufacturer's standard sections as required for support and alignment of metal panel system.
- B. Panel Accessories: Provide components required for a complete, weathertight panel system including trim, copings, fasciae, mullions, sills, corner units, clips, flashings, sealants, gaskets, fillers, closure strips, and similar items. Match material and finish of metal panels unless otherwise indicated.
 1. Closures: Provide closures at eaves and ridges, fabricated of same metal as metal panels.
 2. Backing Plates: Provide metal backing plates at panel end splices, fabricated from material recommended by manufacturer.
 3. Closure Strips: Closed-cell, expanded, cellular, rubber or crosslinked, polyolefin-foam or closed-cell laminated polyethylene; minimum 1 inch thick, flexible closure strips; cut or premolded to match metal panel profile. Provide closure strips where indicated or necessary to ensure weathertight construction.

**NISQUALLY STATE PARK
NEW FULL SERVICE PARK – PHASE 2**

- C. Flashing and Trim: Provide flashing and trim formed from same material as metal panels as required to seal against weather and to provide finished appearance. Locations include, but are not limited to, eaves, rakes, corners, bases, framed openings, ridges, fasciae, and fillers. Finish flashing and trim with same finish system as adjacent metal panels.
- D. Panel Fasteners: Self-tapping screws designed to withstand design loads.
- E. Panel Sealants: Provide sealant type recommended by manufacturer that are compatible with panel materials, are nonstaining, and do not damage panel finish.
 - 1. Sealant Tape: Pressure-sensitive, 100 percent solids, gray polyisobutylene compound sealant tape with release-paper backing; 1/2 inch wide and 1/8 inch thick.
 - 2. Joint Sealant: ASTM C920; as recommended in writing by metal roof panel manufacturer and complying with Section 079200.
 - 3. Butyl-Rubber-Based, Solvent-Release Sealant: ASTM C1311.

2.7 FABRICATION

- A. Fabricate and finish metal panels and accessories at the factory, by manufacturer's standard procedures and processes, as necessary to fulfill indicated performance requirements demonstrated by laboratory testing. Comply with indicated profiles and with dimensional and structural requirements.
- B. Provide panel profile, including major ribs and intermediate stiffening ribs, if any, for full length of panel.
- C. Fabricate metal panel joints with factory-installed sealant that provide a weathertight seal and prevent metal-to-metal contact, and that minimize noise from movements.
- D. Sheet Metal Flashing and Trim: Fabricate flashing and trim to comply with manufacturer's recommendations and recommendations in SMACNA's "Architectural Sheet Metal Manual" that apply to design, dimensions, metal, and other characteristics of item indicated.
 - 1. Form exposed sheet metal accessories that are without excessive oil canning, buckling, and tool marks and that are true to line and levels indicated, with exposed edges folded back to form hems.
 - 2. Seams: Fabricate nonmoving seams in accessories with flat-lock seams. Tin edges to be seamed, form seams, and solder.
 - 3. Sealed Joints: Form nonexpansion, but movable, joints in metal to accommodate sealant and to comply with SMACNA standards.
 - 4. Conceal fasteners and expansion provisions where possible. Exposed fasteners are not allowed on faces of accessories exposed to view.
 - 5. Fabricate cleats and attachment devices from same material as accessory being anchored or from compatible, noncorrosive metal recommended in writing by metal panel manufacturer.
 - a. Size: As recommended by SMACNA's "Architectural Sheet Metal Manual" or metal panel manufacturer for application, but not less than thickness of metal being secured.

**NISQUALLY STATE PARK
NEW FULL SERVICE PARK – PHASE 2**

2.8 FINISHES

- A. Protect mechanical and painted finishes on exposed surfaces from damage by applying a strippable, temporary protective covering before shipping.
- B. Appearance of Finished Work: Variations in appearance of abutting or adjacent pieces are acceptable if they are within 1/2 of range of approved Samples. Noticeable variations in same piece are unacceptable. Variations in appearance of other components are acceptable if they are within range of approved Samples and are assembled or installed to minimize contrast.
- C. Steel Panels and Accessories:
 - 1. 3-Coat Fluoropolymer: AAMA 621. Fluoropolymer finish containing not less than 70 percent polyvinylidene fluoride (PVDF) resin by weight in both color coat and clear topcoat. Prepare, pretreat, and apply coating to exposed metal surfaces to comply with coating and resin manufacturers' written instructions.
 - 2. Concealed Finish: Apply pretreatment and manufacturer's standard white or light-colored acrylic or polyester backer finish consisting of prime coat and wash coat with a minimum total dry film thickness of 0.5 mil.

PART 3 - EXECUTION

3.1 EXAMINATION

- A. Examine substrates, areas, and conditions, with Installer present, for compliance with requirements for installation tolerances, metal panel supports, and other conditions affecting performance of Work.
 - 1. Examine primary and secondary roof framing to verify that rafters, purlins, angles, channels, and other structural panel support members and anchorages have been installed within alignment tolerances required by metal roof panel manufacturer.
 - 2. Examine solid roof sheathing to verify that sheathing joints are supported by framing or blocking, and that installation is within flatness tolerances required by metal roof panel manufacturer.
 - a. Verify that air- or water-resistive barriers have been installed over sheathing or backing substrate to prevent air infiltration or water penetration.
- B. Examine roughing-in for components and systems penetrating metal panels to verify actual locations of penetrations relative to seam locations of metal panels before installation.
- C. Proceed with installation only after unsatisfactory conditions have been corrected.

3.2 PREPARATION

- A. Miscellaneous Supports: Install subframing, furring, and other miscellaneous panel support members and anchorages according to ASTM C754 and metal panel manufacturer's written recommendations.

**NISQUALLY STATE PARK
NEW FULL SERVICE PARK – PHASE 2**

3.3 INSTALLATION OF VAPOR-RETARDER

- A. Self-Adhering-Sheet Vapor Retarder (SA.SVR): Prime substrate if required by manufacturer. Install self-adhering-sheet vapor retarder over area to receive vapor retarder, side and end lapping each sheet a minimum of 3-1/2 and 6 inches, respectively.
 - 1. Extend vertically up parapet walls and projections to a minimum height equal to height of insulation and cover board.
 - 2. Seal laps by rolling to ensure completely sealed laps.
- B. Completely seal vapor retarder at terminations, obstructions, and penetrations to prevent air movement into roofing system.

3.4 INSTALLATION OF INSULATION

- A. Coordinate installing roofing system components so insulation is not exposed to precipitation or left exposed at end of workday.
- B. Comply with roofing system and insulation manufacturer's written instructions for installing roof insulation.
- C. Installation Over Wood Panel Decking:
 - 1. If required by insulation manufacturer, mechanically fasten slip sheet to roof deck using mechanical fasteners specifically designed and sized for fastening slip sheet to wood panel decks.
 - a. Fasten slip sheet according to requirements in SPRI's Directory of Roof Assemblies for specified Wind Uplift Load Capacity.
 - b. Fasten slip sheet to resist specified uplift pressure at corners, perimeter, and field of roof.
 - 2. Install base layer of insulation with joints staggered as follows:
 - a. 48 by 48 Inch Insulation Boards: End joints within each layer not less than 24 inches in adjacent rows.
 - b. 48 by 96 Inch Insulation Boards: Stagger long joints continuous and end joints within each layer not less than 12 inches in adjacent rows.
 - c. Trim insulation neatly to fit around penetrations and projections, and to fit tight to intersecting sloping roof decks.
 - d. Make joints between adjacent insulation boards not more than 1/4 inch in width.
 - e. Fill gaps exceeding 1/4 inch with insulation.
 - f. Cut and fit insulation within 1/4 inch of nailers, projections, and penetrations.
 - g. Fully adhere base layer of insulation using adhesive specifically formulated for adhering specified board-type roof insulation to substrate board.
 - 3. Install upper layers of insulation with joints of each layer offset not less than 12 inches from previous layer of insulation and as follows:

**NISQUALLY STATE PARK
NEW FULL SERVICE PARK – PHASE 2**

- a. 48 by 48 Inch Insulation Boards: End joints within each layer not less than 24 inches in adjacent rows.
- b. 48 by 96 Inch Insulation Boards: Stagger long joints continuous and end joints within each layer not less than 12 inches in adjacent rows.
- c. Trim insulation neatly to fit around penetrations and projections, and to fit tight to intersecting sloping roof decks.
- d. Make joints between adjacent insulation boards not more than 1/4 inch in width.
- e. Fill gaps exceeding 1/4 inch with insulation.
- f. Cut and fit insulation within 1/4 inch of nailers, projections, and penetrations.
- g. Set each layer of insulation in ribbons of bead-applied insulation adhesive, firmly pressing and maintaining insulation in place.

3.5 INSTALLATION OF COVER BOARD

- A. Install cover boards over insulation with long joints in continuous straight lines and end joints staggered between rows. Offset joints of insulation below a minimum of 6 inches in each direction.
 1. Trim cover board neatly to fit around penetrations and projections.
 2. Cut and fit cover board tight to nailers, projections, and penetrations.
 3. Adhere cover board to substrate by setting cover board in a uniform coverage of full-spread insulation adhesive and firmly pressing and maintaining insulation in place.

3.6 INSTALLATION OF UNDERLAYMENT AND FLASHING

- A. Underlayments: Install underlayment as specified in Section 073013 – Roofing Underlayments.
- B. Flashings: Install flashings to cover underlayment to comply with requirements specified in Section 076200 – Sheet Metal Flashing and Trim.

3.7 INSTALLATION OF STANDING SEAM METAL ROOF PANELS

- A. Install metal panels according to manufacturer's written instructions in orientation, sizes, and locations indicated. Install panels perpendicular to supports unless otherwise indicated. Anchor metal panels and other components of Work securely in place, with provisions for thermal and structural movement.
 1. Shim or otherwise plumb substrates receiving metal panels.
 2. Flash and seal metal panels at perimeter of openings.
 - a. Fasten with self-tapping screws.
 - b. Do not begin installation until air- or water-resistive barriers and flashings that will be concealed by metal panels are installed.
 3. Install screw fasteners in predrilled holes.
 4. Locate and space fastenings in uniform vertical and horizontal alignment.
 5. Install flashing and trim as metal panel Work proceeds.
 6. Locate panel splices over, but not attached to, structural supports.

**NISQUALLY STATE PARK
NEW FULL SERVICE PARK – PHASE 2**

- a. Stagger panel splices and end laps to avoid a 4-panel lap splice condition.
 7. Align bottoms of metal panels and fasten with blind rivets, bolts, or self-tapping screws.
 - a. Fasten flashings and trim around openings and similar elements with self-tapping screws.
 8. Provide weathertight escutcheons for pipe- and conduit-penetrating panels.
- B. Fasteners:
1. Use stainless steel fasteners for surfaces exposed to exterior; use galvanized-steel fasteners for surfaces exposed to interior.
- C. Anchor Clips: Anchor metal roof panels and other components of Work securely in place, using manufacturer's approved fasteners according to manufacturers' written instructions.
- D. Metal Protection: Where dissimilar metals contact each other or corrosive substrates, protect against galvanic action as recommended in writing by metal panel manufacturer.
- E. Standing-Seam Metal Roof Panel Installation: Fasten metal roof panels to supports with concealed clips at each standing-seam joint at location, spacing, and with fasteners recommended in writing by manufacturer.
1. Install clips to supports with self-tapping fasteners.
 2. Install pressure plates at locations indicated in manufacturer's written installation instructions.
 3. Seamed Joint: Crimp standing seams with manufacturer-approved, motorized seamer tool so clip, metal roof panel, and factory-applied sealant are completely engaged.
 4. Watertight Installation:
 - a. Apply a continuous ribbon of sealant to seal joints of metal panels, using sealant as recommend in writing by manufacturer as needed to make panels watertight.
 - b. Provide sealant between panels and protruding equipment, vents, and accessories.
 - c. At panel splices, nest panels with minimum 6 inch end lap, sealed with sealant and fastened together by interlocking clamping plates.
- F. Accessory Installation: Install accessories with positive anchorage to building and weathertight mounting, and provide for thermal expansion. Coordinate installation with flashings and other components.
1. Install components required for a complete metal panel system including trim, copings, corners, seam covers, flashings, sealants, gaskets, fillers, closure strips, and similar items. Provide types indicated by metal roof panel manufacturers; or, if not indicated, types recommended by metal roof panel manufacturer.
- G. Flashing and Trim: Comply with performance requirements, manufacturer's written installation instructions, and SMACNA's "Architectural Sheet Metal Manual." Provide concealed fasteners where possible, and set units true to line and level as indicated. Install Work with laps, joints, and seams that will be permanently watertight and weather resistant.

**NISQUALLY STATE PARK
NEW FULL SERVICE PARK – PHASE 2**

1. Install exposed flashing and trim that is without buckling and tool marks, and that is true to line and levels indicated, with exposed edges folded back to form hems. Install sheet metal flashing and trim to fit substrates and achieve waterproof and weather-resistant performance.
2. Expansion Provisions: Provide for thermal expansion of exposed flashing and trim. Space movement joints at a maximum of 10 feet with no joints allowed within 24 inches of corner or intersection. Where lapped expansion provisions cannot be used or would not be sufficiently weather resistant and waterproof, form expansion joints of intermeshing hooked flanges, not less than 1 inch deep, filled with mastic sealant (concealed within joints).

H. Pipe Flashing: Form flashing around pipe penetration and metal roof panels. Fasten and seal to metal roof panels as recommended by manufacturer.

3.8 ERECTION TOLERANCES

- A. Installation Tolerances: Shim and align metal panel units within installed tolerance of 1/4 inch in 20 feet on slope and location lines as indicated and within 1/8 inch offset of adjoining faces and of alignment of matching profiles.

3.9 REPAIR

- A. Replace standing-seam metal panels that have been damaged or have deteriorated beyond successful repair by finish touchup or similar minor repair procedures.

3.10 FIELD QUALITY CONTROL

- A. Manufacturer's Field Service: Engage a factory-authorized service representative to test and inspect metal roof panel installation, including accessories. Report results in writing.
- B. Remove and replace applications of metal roof panels where tests and inspections indicate that they do not comply with specified requirements.
- C. Additional tests and inspections, at Contractor's expense, are performed to determine compliance of replaced or additional Work with specified requirements.
- D. Prepare test and inspection reports.

3.11 CLEANING

- A. On completion of standing-seam metal panel installation, remove unused materials.
- B. Clean exposed metal finished surfaces as recommended in writing by standing-seam metal panel manufacturer. Clear weep holes and drainage channels of obstructions, dirt, and sealant.

**NISQUALLY STATE PARK
NEW FULL SERVICE PARK – PHASE 2**

3.12 PROTECTION

- A. Remove temporary protective coverings and strippable films as standing-seam metal panels are installed unless otherwise indicated in manufacturer's written installation instructions.
- B. Maintain standing-seam metal panels in clean condition during construction.

END OF SECTION

**NISQUALLY STATE PARK
NEW FULL SERVICE PARK – PHASE 2**

SECTION 074293 SOFFIT PANELS

PART 1 - GENERAL

1.1 SUMMARY

A. Section Includes:

1. Fiber-cement soffits.

1.2 ADMINISTRATIVE REQUIREMENTS

A. Coordination:

1. Coordinate fiber-cement panel assemblies with rain drainage Work, flashing, trim, construction of soffits, and other adjoining Work to provide a leakproof, secure, and noncorrosive installation.

B. Preinstallation Meetings: Conduct meeting at Project site.

1. Comply with preinstallation meeting requirements in Section 074646 – Fiber-Cement Siding.

1.3 ACTION SUBMITTALS

A. Product Data: For each type of product.

1. Include construction details, material descriptions, dimensions of individual components and profiles, and finishes for each type of panel and accessory.

B. Shop Drawings:

1. Include detailed drawings of atypical, non-standard applications of cementitious soffit materials which are outside scope of standard details and specifications provided by manufacturer.
2. Accessories: Include details of flashing, trim, and anchorage systems, at a scale of not less than 1-1/2 inches per 12 inches.

C. Samples for Verification: For each type of exposed finish required, prepared on Samples of size indicated below:

1. Fiber-Cement Soffits: 12 inch long by actual width Sample of soffit.
2. 12 inch long by actual width Samples of trim and accessories.

**NISQUALLY STATE PARK
NEW FULL SERVICE PARK – PHASE 2**

1.4 INFORMATIONAL SUBMITTALS

- A. Qualification Data: For Installer.
- B. Product Test Reports: For each product, tests performed by a qualified testing agency.
- C. Sample Warranties: For special warranties.

1.5 CLOSEOUT SUBMITTALS

- A. Maintenance Data: For fiber-cement panels to include in maintenance manuals.

1.6 QUALITY ASSURANCE

- A. Manufacturer Qualifications: A firm that specializes in manufacturing of specified soffit panel systems with a minimum of 10 years of documented experience.
- B. Installer Qualifications: An entity that employs installers and supervisors who are trained and approved by manufacturer with a minimum of 5 years of documented experience.
- C. Mockups:
 - 1. Build mockup as indicated in Section 074646 – Fiber-Cement Siding.
 - 2. Approval of mockups does not constitute approval of deviations from Contract Documents contained in mockups unless Architect specifically approves such deviations in writing.
 - 3. Subject to compliance with requirements, approved mockups may become part of completed Work if undisturbed at time of Substantial Completion.

1.7 DELIVERY, STORAGE, AND HANDLING

- A. Deliver components, fiber-cement panels, and other manufactured items so as not to be damaged or deformed. Package panels for protection during transportation and handling.
- B. Unload, store, and erect fiber-cement panels in a manner to prevent cracking, chipping, and breaking.
- C. Stack panels horizontally on platforms or pallets, covered with suitable weathertight and ventilated covering. Store panels to ensure dryness, with positive slope for drainage of water. Do not store panels in contact with other materials that might cause staining, denting, or other surface damage.

1.8 FIELD CONDITIONS

- A. Weather Limitations: Proceed with installation only when existing and forecasted weather conditions permit assembly of panels to be performed according to manufacturers' written instructions and warranty requirements.

**NISQUALLY STATE PARK
NEW FULL SERVICE PARK – PHASE 2**

1.9 WARRANTY

- A. Special Warranty: Manufacturer agrees to repair or replace components of fiber-cement systems that fail in materials or workmanship within specified warranty period.
 - 1. Failures include structural failures including cracking and deforming, and deterioration of materials beyond normal weathering.
 - 2. Warranty Period: 30 years from date of Substantial Completion.

PART 2 - PRODUCTS

2.1 MANUFACTURERS

- A. Source Limitations: Obtain fiber-cement soffit panels and FC.SIDING-2 from single source from single manufacturer.

2.2 PERFORMANCE CRITERIA

- A. Thermal Movements: Allow for thermal movements from ambient and surface temperature changes by preventing buckling, opening of joints, overstressing of components, failure of joint sealants, failure of connections, and other detrimental effects. Base calculations on surface temperatures of materials due to both solar heat gain and nighttime-sky heat loss.
 - 1. Temperature Change (Range): 120 degrees F, ambient; 180 degrees F, material surfaces.
- B. Structural Performance: Provide fiber-cement siding systems capable of withstanding effects of the following loads, based on testing according to ASTM E330:
 - 1. Wind Loads and Other Design Loads: As indicated on Drawings.
- C. Seismic Performance: Exterior fiber-cement siding systems, including anchors and connections, shall withstand effects of earthquake motions determined according to ASCE 7.
- D. Fire-Resistance Ratings: Comply with ASTM E119; testing by a qualified testing agency. Identify products with appropriate markings of applicable testing agency.

2.3 FIBER-CEMENT SOFFIT PANELS

- A. Composition: ASTM C1186 Type A, Grade II fiber-cement soffits are manufactured from Portland cement, sand, water, cellulose fibers, and manufacturers' proprietary additives.
- B. Noncombustible when tested according to ASTM E136.
- C. Surface Burning Characteristics: ASTM E84; Class A:
 - 1. Flame Spread: 0.
 - 2. Smoke Developed: 25.

**NISQUALLY STATE PARK
NEW FULL SERVICE PARK – PHASE 2**

- D. Labeling: Provide fiber-cement siding that is tested and labeled according to ASTM C1186 by a qualified testing agency acceptable to AHJ.
- E. Fiber-cement soffit panels from same collection as FC.SIDING-2 and complying with the following:
 - 1. Factory primed with manufacturer's standard acrylic primer.

2.4 MISCELLANEOUS MATERIALS, FIBER-CEMENT SOFFIT PANELS

- A. Fasteners: Stainless steel for fastening fiber cement.
 - 1. For fastening to wood, use siding nails or ribbed bugle-head screws of sufficient length to penetrate a minimum of 1 inch into substrate.
- B. Continuous Soffit Vents: Aluminum, hat-channel shape, with perforations; 2 inches wide and not less than 96 inches long.
 - 1. Net-Free Area: Minimum of 6 sq. in./linear ft.
 - 2. Finish: Mill finish unless indicated otherwise.
- C. Insect Screening for Soffit Vents: Stainless steel, 18 by 18 mesh.
- D. Paint: As specified in Section 099000 –Painting and Coating, and acceptable to fiber-cement siding manufacturer.
 - 1. Provide primer acceptable to fiber-cement panel manufacturer if panels are not shop-primed.
- E. Joint Sealant: SLNT-U3 urethane sealant, as specified in Section 079200 and acceptable to fiber-cement manufacturer, that provides 2 sided adhesion.
 - 1. Color: Match color of fiber-cement components.

2.5 FABRICATION

- A. Fabricate and finish fiber-cement panels and accessories at factory, by manufacturer's standard procedures and processes, and as necessary to fulfill indicated performance requirements demonstrated by laboratory testing. Comply with indicated profiles and with dimensional and structural requirements.

PART 3 - EXECUTION

3.1 EXAMINATION

- A. Examine substrates, areas, and conditions, with Installer present, for compliance with requirements for installation tolerances, panel supports, and other conditions affecting performance of Work.

**NISQUALLY STATE PARK
NEW FULL SERVICE PARK – PHASE 2**

- B. Examine substrates for compliance with requirements for installation tolerances and other conditions affecting performance of fiber-cement soffit and related accessories.
- C. Proceed with installation only after unsatisfactory conditions have been corrected.

3.2 INSTALLATION OF FIBER-CEMENT PANELS

- A. Comply with manufacturer's written installation instructions applicable to products and applications indicated unless more stringent requirements apply.
 - 1. Do not install damaged components.
 - 2. Install fasteners no more than 16 inches on center.
 - 3. Clean cut and exposed panel edges and apply cut edge sealer.
 - 4. Install joint sealants to produce a weathertight installation where indicated or required.
- B. Soffit Panels:
 - 1. Before installing soffit panels, install insect screen over ventilation holes on back of soffit panel using fasteners or adhesive.
 - 2. Fasten soffit panels to soffit subframing using fasteners acceptable to soffit panel manufacturer.
 - 3. Install fiber-cement soffit panels with minimum space between butt joints to allow for thermal movement.
 - 4. Align butt joints over center of subframing members.
 - 5. Install soffit panels with ventilation holes oriented away from building.

3.3 REPAIR AND CLEANING

- A. Replace panels that have been damaged or have deteriorated beyond successful repair by finish touchup or similar minor repair procedures.
- B. Clean finished surfaces according to manufacturer's written instructions and maintain in a clean condition during construction.
- C. Where required by Federal, state, or local jurisdictions, provide acceptable means of containing and disposing of dust and debris created by handling, cutting, and installing of fiber-cement panels.

END OF SECTION

**NISQUALLY STATE PARK
NEW FULL SERVICE PARK – PHASE 2**

SECTION 074646 – FIBER-CEMENT SIDING

PART 1 - GENERAL

1.1 SUMMARY

A. Section Includes:

1. Fiber-cement siding.

B. Related Requirements:

1. Section 074293 – Soffit Panels, for fiber-cement soffits.

1.2 ADMINISTRATIVE REQUIREMENTS

A. Coordination:

1. Coordinate siding installation with flashings and other adjoining construction to ensure proper sequencing.

B. Preinstallation Meetings: Conduct Meeting at Project site.

1.3 ACTION SUBMITTALS

A. Product Data: For each type of product.

B. Shop Drawings:

1. Provide detailed drawings of atypical, non-standard applications of cementitious siding materials which are outside scope of standard details and specifications provided by manufacturer.

C. Samples for Verification:

1. 12 inch long by actual width Sample of siding.
2. 12 inch long by actual width Samples of trim and accessories.

1.4 INFORMATIONAL SUBMITTALS

A. Product Certificates: For each type of fiber-cement siding.

B. Sealant Certification: From fiber-cement manufacturer indicating acceptance of proposed joint sealant.

**NISQUALLY STATE PARK
NEW FULL SERVICE PARK – PHASE 2**

- C. Product Test Reports: Based on evaluation of comprehensive tests performed by a qualified testing agency, for fiber-cement siding.
 - D. Research/Evaluation Reports: For each type of fiber-cement siding required, from ICC-ES.
 - E. Sample Warranty: For special warranty.
- 1.5 CLOSEOUT SUBMITTALS
- A. Maintenance Data: For each type of product, including related accessories, to include in maintenance manuals.
- 1.6 MAINTENANCE MATERIAL SUBMITTALS
- A. Furnish extra materials that match products installed and that are packaged with protective covering for storage and identified with labels describing contents.
 - 1. Furnish full lengths of fiber-cement siding, including related accessories, in a quantity equal to 2 percent of amount installed.
- 1.7 QUALITY ASSURANCE
- A. Installer Qualifications: An entity specializing in performing type of work specified and approved by manufacturer with a minimum of 3 years of documented experience.
 - B. Mockups:
 - 1. Build mockup of typical wall area as shown on Drawings.
 - 2. Build mockups for fiber-cement siding and soffit, including related accessories.
 - a. Size: 48 inches long by 60 inches high.
 - b. Include outside corner on one end of mockup and inside corner on other end.
 - 3. Approval of mockups does not constitute approval of deviations from Contract Documents contained in mockups unless Architect specifically approves such deviations in writing.
 - 4. Subject to compliance with requirements, approved mockups may become part of completed Work if undisturbed at time of Substantial Completion.
- 1.8 DELIVERY, STORAGE, AND HANDLING
- A. Deliver and store packaged materials in original containers with labels intact until time of use. Store materials on elevated platforms, under cover, and in a dry location.

**NISQUALLY STATE PARK
NEW FULL SERVICE PARK – PHASE 2**

1.9 WARRANTY

- A. Special Warranty: Manufacturer agrees to repair or replace products that fail in materials or workmanship within specified warranty period.
 - 1. Failures include the following:
 - a. Structural failures including cracking and deforming.
 - b. Deterioration of materials beyond normal weathering.
 - 2. Warranty Period FC.SIDING-1: 50 years from date of Substantial Completion.
 - 3. Warranty Period FC.SIDING-2: 30 years from date of Substantial Completion.
 - 4. Warranty Period FC.SIDING-2 Trim Boards: 15 years from date of Substantial Completion.
- B. Special Warranty on Panel Finishes: Manufacturer agrees to repair finish or replace fiber-cement panels that show evidence of deterioration of factory-applied finishes within specified warranty period. Deterioration includes the following:
 - 1. Cracking, checking, peeling, or failure of paint to adhere to bare metal.
 - 2. Warranty Period FC.SIDING-1: Minimum 20 years from date of Substantial Completion.

PART 2 - PRODUCTS

2.1 MANUFACTURERS

- A. Source Limitations: Obtain FC.SIDING-2 and soffit panels from single source from single manufacturer.

2.2 PERFORMANCE CRITERIA

- A. Structural Performance: Provide fiber-cement siding systems capable of withstanding effects of the following loads, based on testing according to ASTM E330:
 - 1. Wind Loads and Other Design Loads: As indicated on Drawings.
- B. Seismic Performance: Exterior fiber-cement siding systems, including anchors and connections, shall withstand effects of earthquake motions determined according to ASCE 7.
 - 1. Component Importance Factor: 1.0.
- C. Fire-Resistance Ratings: Comply with ASTM E119; testing by a qualified testing agency. Identify products with appropriate markings of applicable testing agency.

**NISQUALLY STATE PARK
NEW FULL SERVICE PARK – PHASE 2**

2.3 FIBER-CEMENT PRODUCTS, GENERAL

- A. Composition: ASTM C1186 Type A, Grade II fiber-cement siding, soffits, and trim are manufactured from Portland cement, sand, water, cellulose fibers, and manufacturers' proprietary additives.
- B. Noncombustible when tested according to ASTM E136.
- C. Surface Burning Characteristics: ASTM E84; Class A:
 - 1. Flame Spread: 0.
 - 2. Smoke Developed: 25.
- D. Labeling: Provide fiber-cement siding that is tested and labeled according to ASTM C1186 by a qualified testing agency acceptable to authorities having jurisdiction.

2.4 FIBER-CEMENT SIDING (FC.SIDING-1)

- A. Basis-of-Design Product: Subject to compliance with requirements, provide the following:
 - 1. KMEW USA Inc.: CERACLAD Rain Screen Exterior Siding System.
 - 2. Approved substitution.
- B. Panel Size: 10 inch by 10 feet.
- C. Panel Thickness: Not less than 5/8 inch.
- D. Profile: Urban Cedar.
- E. Panel Texture: Wood grain texture.
- F. Factory finished with manufacturer's standard 3 coat finish with anti-efflorescence protection.
 - 1. Prefinished Color: Honey NH4992U.
- G. Fiber-Cement Trim: Fiber-cement corner units from same collection and same material as panels.
 - 1. Thickness: Not less than 5/8 inch.
 - 2. Returns: 3-3/16 inch each side.
 - 3. Vertical Corner:
 - a. Length: 120 inches
 - b. Coverage: 5.9 sq. ft.
 - 4. Horizontal Corner:
 - a. Length: 18 inches
 - b. Coverage: 0.89 sq. ft.

**NISQUALLY STATE PARK
NEW FULL SERVICE PARK – PHASE 2**

5. Factory-finished with manufacturer's standard 3 coat finish with anti-efflorescence protection.
 - a. Prefinished Color: Match color of FC.SIDING-1.
 - H. Drainage Furring Channels: ASTM C955; hat-shaped steel furring channels with dimpled face and punched sides to minimize effects of hydrostatic pressure and allow ventilation behind siding system.
 1. Material: 0.0451 inch thick galvanized structural steel, Grade 33, with G90 coating.
 2. Minimum Base-Metal Thickness:
 3. Depth: 3/4 inch.
 4. Width: 4-3/4 inches overall with 3 inch wide face and 3/4 inch wide legs.
 - I. Installation Components: Materials recommended by fiber-cement siding manufacturer for intended use, compatible with rainscreen siding system, and matching color and texture of adjacent siding unless otherwise indicated:
 1. Starter Bars: Galvanized steel.
 2. Caulking Joiner: Aluminum-zinc-magnesium alloy coated steel.
 3. Panel and Corner Clips: Aluminum-zinc-magnesium alloy coated steel.
 4. Cut Edge Sealer: Concrete sealer recommended by fiber-cement siding manufacturer.
 5. Joint Sealant: SLNT-U3 silicone sealant as specified in Section 079200.
 - a. Color: Match color of fiber-cement components.
 6. Touch-up Paint Kit: Provided by fiber-cement siding manufacturer.
- 2.5 FIBER-CEMENT SIDING (FC.SIDING-2)
- A. Basis-of-Design Product: Subject to compliance with requirements, provide the following:
 1. James Hardie Building Products, Inc.: HardiePanel HZ5 Lap Siding Beaded Smooth.
 2. Approved substitution.
 - B. Nominal Thickness: Not less than 7/16 inch.
 - C. Horizontal Pattern: Boards 8-1/4 to 8-1/2 inches wide in beaded-edge style.
 - D. Panel Texture: Smooth texture, unless indicated otherwise.
 - E. Factory primed with manufacturer's standard acrylic primer.

2.6 ACCESSORIES

- A. Siding Accessories, General: Provide starter strips, edge trim, outside and inside corner caps, and other items as recommended or provided by fiber-cement panel manufacturer for Project configuration.
 1. Provide accessories matching color and texture of adjacent siding unless otherwise indicated.

**NISQUALLY STATE PARK
NEW FULL SERVICE PARK – PHASE 2**

- B. Closures Components: Premanufactured products complying with the following:
 - 1. Material: 0.015 inch thick aluminum.
 - 2. Sizes:
 - a. Corners: As indicated on Drawings.
 - b. Junction Flashing: 6 inches wide for 3 inch coverage on each side of butt joints.
 - 3. Surface: Match siding texture.
 - 4. Finish: Manufacturer's standard primer on exposed surfaces and epoxy coating on concealed surfaces.
- C. Flashing: Provide stainless-steel flashing complying with Section 076200 – Sheet Metal Flashing and Trim at window and door heads and where indicated.
- D. Fasteners: Stainless steel for fastening fiber cement.
 - 1. For fastening to wood, use siding nails or ribbed bugle-head screws of sufficient length to penetrate a minimum of 1 inch into substrate.
- E. Paint: As specified in Section 099000 –Painting and Coating, and acceptable to fiber-cement siding manufacturer.
 - 1. Provide primer acceptable to fiber-cement panel manufacturer if panels are not shop-primed.
- F. Joint Sealant: SLNT-U3 urethane sealant, as specified in Section 079200 and acceptable to fiber-cement manufacturer, that provides 2 sided adhesion.
 - 1. Color: Match color of fiber-cement components.

PART 3 - EXECUTION

3.1 EXAMINATION

- A. Examine substrates for compliance with requirements for installation tolerances and other conditions affecting performance of fiber-cement siding and related accessories.
- B. Verify that weather or air barrier has been installed over substrate completely and correctly, and is ready to receive Work of this Section.
- C. Verify that flashing is installed above door and window trim and casings, above horizontal trim between panels, and where else indicated.
- D. Proceed with installation only after unsatisfactory conditions have been corrected.

3.2 PREPARATION

- A. Clean substrates of projections and substances detrimental to application.

**NISQUALLY STATE PARK
NEW FULL SERVICE PARK – PHASE 2**

3.3 INSTALLATION

- A. Comply with manufacturer's written installation instructions applicable to products and applications indicated unless more stringent requirements apply.
1. Do not install damaged components.
 2. Install fasteners no more than 16 inches on center.
 3. Clean cut and exposed panel edges and apply cut edge sealer.
 4. Install joint sealants to produce a weathertight installation where indicated or required.
- B. FC.SIDING-1:
1. Begin panel installation at left hand inside or outside corner. Continue working left to right and bottom to top.
 2. Seat flat edge of panel on vertical starter bar.
 3. Install first clip as close to starter bar as possible and no more than 3 inches above starter bar. Install additional clips within 3 inches of panel edges.
 4. Install panel clips to ship-lapped edge of panel minimum 16 inches on center to secure panel to wall and to maintain desired cavity for air circulation.
 5. Fit panels tightly together on both horizontal and vertical joints ensuring that panel edges are properly seated in clips.
 6. Do not directly fasten items to panels. Provide blocking behind panel and fasten objects through panels into blocking and building frame.
- C. FC.SIDING-2:
1. Install minimum 1/4 inch thick starter strip at bottom course of wall. Apply planks horizontally with bottom edge of first plank overlapping starter strip and minimum 1-1/4 inch wide laps at top.
 2. Allow minimum vertical clearance between edge of siding and other materials in accordance with manufacturer's installation instructions
 3. Install fiber-cement boards with minimum space between butt joints to allow for thermal movement.
 4. Align vertical butt joints over center of framing members.
 - a. Vertical butt joints not installed this way will be unacceptable.
 5. Space butt joints occurring in adjacent planks a minimum of 32 inches apart to avoid stair-step pattern of vertical butt joints.
 6. Locate vertical butt joints a minimum of 12 inches away from standing trim at door and window openings.
 7. Install joint sealants between boards to produce a weathertight installation where indicated or required.
- D. Trim Boards:
1. Install materials according to siding manufacturer's written instructions.
 2. Ensure flashing is installed around wall openings.
 3. Fasten trim into framing, sheathing, or blocking as indicated on Drawings, using manufacturer's recommended fasteners at manufacturer's recommended spacing.

**NISQUALLY STATE PARK
NEW FULL SERVICE PARK – PHASE 2**

4. Inside Corners: Trim with single board trim both sides of corner.
5. Outside Corners: Attach trim on both sides of corner.
6. Allow 1/8 inch gap between trim and siding.
7. Seal gap with specified joint sealant.
8. Fasten through overlapping boards. Do not nail between lap joints.

E. Roof Edge Flashing:

1. Where vertical surfaces of fiber-cement panels meet roof edge flashing, provide 2 inch clearance between flashing and edge of fiber-cement panels, or as recommended by fiber cement siding manufacturer.

F. Tolerances:

1. Maximum Variation of Siding Courses: Plumb, level, and out of plane within 1/4 inch tolerance in 10 foot.
2. Maximum Offset Joint Alignment: 1/16 inch.

3.4 ADJUSTING

- A. Remove damaged, improperly installed, or otherwise defective materials and replace with new materials complying with specified requirements.

3.5 CLEANING

- A. Clean finished surfaces according to manufacturer's written instructions and maintain in a clean condition during construction.
- B. Where required by Federal, state, or local jurisdictions, provide acceptable means of containing and disposing of dust and debris created by handling, cutting, and installing of fiber-cement panels.

END OF SECTION

**NISQUALLY STATE PARK
NEW FULL SERVICE PARK – PHASE 2**

SECTION 076200 – SHEET METAL FLASHING AND TRIM

PART 1 - GENERAL

1.1 SUMMARY

A. Section Includes:

1. Manufactured through-wall flashing.
2. Manufactured reglets with counterflashing.
3. Formed roof-drainage sheet metal fabrications.
4. Formed low-slope roof sheet metal fabrications.
5. Formed wall sheet metal fabrications.

B. Related Requirements:

1. Section 073013 – Roofing Underlayments.
2. Section 076500 – Flexible Flashings.
3. Section 136000 - Kiosks

1.2 ADMINISTRATIVE REQUIREMENTS

A. Coordination:

1. Coordinate sheet metal flashing and trim layout and seams with sizes and locations of penetrations to be flashed, and joints and seams in adjacent materials.
2. Coordinate sheet metal flashing and trim installation with adjoining roofing and wall materials, joints, and seams to provide leakproof, secure, and noncorrosive installation.

B. Preinstallation Meetings: Conduct meeting at Project site.

1. Review construction schedule. Verify availability of materials, Installer's personnel, equipment, and facilities needed to make progress and avoid delays.
2. Review special roof details, roof drainage, roof-penetration flashing, equipment curbs, and condition of other construction that affect sheet metal flashing and trim.
3. Review requirements for insurance and certificates if applicable.
4. Review sheet metal flashing observation and repair procedures after flashing installation.

1.3 ACTION SUBMITTALS

A. Product Data: For each type of product.

1. Include construction details, material descriptions, dimensions of individual components and profiles, and finishes for each manufactured product and accessory.

**NISQUALLY STATE PARK
NEW FULL SERVICE PARK – PHASE 2**

- B. Shop Drawings: For sheet metal flashing and trim.
1. Include plans, elevations, sections, and attachment details.
 2. Detail fabrication and installation layouts, expansion-joint locations, and keyed details. Distinguish between shop- and field-assembled Work.
 3. Include identification of material, thickness, weight, and finish for each item and location in Project.
 4. Include details for the following conditions:
 - a. Forming sheet metal flashing and trim, including profiles, shapes, seams, and dimensions.
 - b. Joining, supporting, and securing sheet metal flashing and trim, including layout of fasteners, cleats, clips, and other attachments. Include pattern of seams.
 - c. Termination points and assemblies.
 - d. Expansion joints and expansion-joint covers, including showing direction of expansion and contraction from fixed points.
 - e. Roof-penetration flashing.
 - f. Edge conditions, including eaves, ridges, valleys, rakes, crickets, and counterflashings as applicable.
 - g. Special conditions.
 - h. Connections to adjoining Work.
 5. Detail formed flashing and trim at a scale of not less than 1-1/2 inches per 12 inches.
- C. Samples for Verification: For each type of exposed finish.
1. Sheet Metal Flashing: 12 inches long by actual width of unit, including finished seam and in required profile. Include fasteners, cleats, clips, closures, and other attachments.
 2. Trim, Metal Closures, Expansion Joints, Joint Intersections, and Miscellaneous Fabrications: 12 inches long and in required profile. Include fasteners and other exposed accessories.
 3. Unit-Type Accessories and Miscellaneous Materials: Full-size Sample.

1.4 INFORMATIONAL SUBMITTALS

- A. Qualification Data: For fabricator.
- B. Product Certificates: For each type of coping and roof edge flashing that is SPRI ES-1 tested.
- C. Product Test Reports: For each product, for tests performed by a qualified testing agency.
- D. Sample Warranty: For special warranty.

1.5 CLOSEOUT SUBMITTALS

- A. Maintenance Data: For sheet metal flashing and trim, and its accessories, to include in maintenance manuals.
- B. Special warranty.

**NISQUALLY STATE PARK
NEW FULL SERVICE PARK – PHASE 2**

1.6 QUALITY ASSURANCE

- A. Fabricator Qualifications: Employs skilled workers who custom fabricate sheet metal flashing and trim similar to that required for this Project and whose products have a record of successful in-service performance.
 - 1. For copings and roof edge flashings that are SPRI ES-1 tested, shop shall be listed as able to fabricate required details as tested and approved.
- B. Mockups:
 - 1. Build mockup of typical roof edge, including gutter and downspout, approximately 10 feet long, including supporting construction, seams, attachments, underlayment, and accessories.
 - 2. Approval of mockups does not constitute approval of deviations from Contract Documents contained in mockups unless Architect specifically approves such deviations in writing.
 - 3. Subject to compliance with requirements, approved mockups may become part of completed Work if undisturbed at time of Substantial Completion.

1.7 DELIVERY, STORAGE, AND HANDLING

- A. Do not store sheet metal flashing and trim materials in contact with other materials that might cause staining, denting, or other surface damage.
 - 1. Store sheet metal flashing and trim materials away from uncured concrete and masonry.
 - 2. Protect stored sheet metal flashing and trim from contact with water.
- B. Protect strippable protective covering on sheet metal flashing and trim from exposure to sunlight and high humidity, except to extent necessary for period of sheet metal flashing and trim installation.

1.8 WARRANTY

- A. Special Warranty on Finishes: Manufacturer agrees to repair finish or replace sheet metal flashing and trim that shows evidence of deterioration of factory-applied finishes within specified warranty period.
 - 1. Exposed Panel Finish: Deterioration includes the following:
 - a. Color fading more than 5 Hunter units when tested per ASTM D2244.
 - b. Chalking in excess of a No. 8 rating when tested per ASTM D4214.
 - c. Cracking, checking, peeling, or failure of paint to adhere to bare metal.
 - 2. Finish Warranty Period: 20 years from date of Substantial Completion.

**NISQUALLY STATE PARK
NEW FULL SERVICE PARK – PHASE 2**

PART 2 - PRODUCTS

2.1 PERFORMANCE CRITERIA

- A. Sheet metal flashing and trim assemblies shall withstand wind loads, structural movement, thermally induced movement, and exposure to weather without failure due to defective manufacture, fabrication, installation, or other defects in construction. Completed sheet metal flashing and trim shall not rattle, leak, or loosen, and shall remain watertight.
- B. Sheet Metal Standard for Flashing and Trim: Comply with NRCA's "The NRCA Roofing Manual" and SMACNA's "Architectural Sheet Metal Manual" requirements for dimensions and profiles shown unless more stringent requirements are indicated.
- C. SPRI Wind Design Standard: Manufacture and install copings and roof edge flashing tested according to SPRI ES-1 and capable of resisting the following design pressure
 - 1. Design Pressure: As indicated on Drawings.
- D. Thermal Movements: Allow for thermal movements from ambient and surface temperature changes to prevent buckling, opening of joints, overstressing of components, failure of joint sealants, failure of connections, and other detrimental effects.
 - 1. Provide clips that resist rotation and avoid shear stress as a result of thermal movements.
 - 2. Base calculations on surface temperatures of materials due to both solar heat gain and nighttime-sky heat loss.
 - 3. Temperature Change (Range): 120 deg F, ambient; 180 deg F, material surfaces.

2.2 SHEET METALS

- A. Protect mechanical and other finishes on exposed surfaces from damage by applying a strippable, temporary protective film before shipping.
- B. Metallic-Coated Steel Sheet: Aluminum-zinc alloy-coated steel sheet in accordance with ASTM A792, Class AZ50 coating designation, Grade 40, prepainted by coil-coating process to comply with ASTM A755.
 - 1. Surface: Smooth, flat.
 - 2. Exposed Coil-Coated Finish:
 - a. 3-Coat Fluoropolymer: AAMA 621. Fluoropolymer finish containing not less than 70 percent PVDF resin by weight in both color coat and clear topcoat. Prepare, pretreat, and apply coating to exposed metal surfaces to comply with coating and resin manufacturers' written instructions.
 - b. Color: Selected by Architect from manufacturer's full range.
 - 3. Concealed Finish: Pretreat with manufacturer's standard white or light-colored acrylic or polyester backer finish, consisting of prime coat and wash coat with a minimum total dry film thickness of 0.5 mil.

**NISQUALLY STATE PARK
NEW FULL SERVICE PARK – PHASE 2**

C. Stainless-Steel Sheet: ASTM A240 or ASTM A666, Type 304, dead soft, fully annealed.

1. Finish: 4 (polished directional satin).
2. Surface: Smooth, flat.

2.3 UNDERLAYMENT MATERIALS

A. Roofing Underlayments: Specified in Section 073013 – Roofing Underlayments.

2.4 MISCELLANEOUS MATERIALS

A. Provide materials and types of fasteners, solder, protective coatings, sealants, and other miscellaneous items as required for complete sheet metal flashing and trim installation and as recommended by manufacturer of primary sheet metal or manufactured item unless otherwise indicated.

B. Fasteners: Wood screws, annular threaded nails, self-tapping screws, self-locking rivets and bolts, and other suitable fasteners designed to withstand design loads and recommended by manufacturer of primary sheet metal or manufactured item.

1. Blind fasteners or self-drilling screws, gasketed, with hex-washer head.
 - a. Exposed Fasteners: Heads matching color of sheet metal using plastic caps or factory-applied coating. Provide metal-backed EPDM or PVC sealing washers under heads of exposed fasteners bearing on weather side of metal.
 - b. Blind Fasteners: High-strength aluminum or stainless-steel rivets suitable for metal being fastened.
 - c. Spikes and Ferrules: Same material as gutter; with spike with ferrule matching internal gutter width.
2. Fasteners for Aluminum-Zinc Alloy-Coated Steel Sheet: Series 300 stainless steel or hot-dip galvanized steel per ASTM A153 or ASTM F2329 or.
3. Fasteners for Stainless-Steel Sheet: Series 300 stainless steel.

C. Solder:

1. For Stainless Steel: ASTM B32, Grade Sn60, with an acid flux of type recommended by stainless-steel sheet manufacturer.
2. For Zinc-Coated (Galvanized) Steel: ASTM B32, Grade Sn50, 50 percent tin and 50 percent lead or Grade Sn60, 60 percent tin and 40 percent lead.

D. Sealant Tape: Pressure-sensitive, 100 percent solids, polyisobutylene compound or closed cell PVC foam tape with high tack solid butyl coating sealant tape with release-paper backing.

1. Size: 1/8 inch thick by 1/2 inch wide.

**NISQUALLY STATE PARK
NEW FULL SERVICE PARK – PHASE 2**

- 2. Application:
 - a. Between sheet metal flashings and associated backing plates and where indicated or recommended by tape manufacturer.
 - b. Use in conjunction with specified joint sealant.
- E. Elastomeric Sealant: ASTM C920, elastomeric polymer sealant; of type, grade, class, and use classifications required to seal joints in sheet metal flashing and trim and remain watertight.
- F. Butyl Sealant: ASTM C1311, single-component, solvent-release butyl rubber sealant; polyisobutylene plasticized; heavy bodied for hooked-type expansion joints with limited movement.

2.5 MANUFACTURED SHEET METAL FLASHING AND TRIM

- A. Reglets: Units of type, material, and profile indicated, formed to provide secure interlocking of separate reglet and counterflashing pieces, and compatible with flashing indicated with factory-mitered and -welded corners and junctions with interlocking counterflashing on exterior face, of same metal as reglet.
 - 1. Manufacturers: Subject to compliance with requirements, provide products by one of the following:
 - a. Cheney Flashing Company.
 - b. Fry Reglet Corporation.
 - c. Keystone Flashing Company, Inc.
 - d. Metal-Era, Inc.
 - 2. Source Limitations: Obtain reglets from single source from single manufacturer.
 - 3. Material: Galvanized Steel, 0.0276 inch thick.
 - 4. Surface-Mounted Type: Provide with slotted holes for fastening to substrate, with neoprene or other suitable weatherproofing washers, and with channel for sealant at top edge.
 - 5. Accessories:
 - a. Flexible-Flashing Retainer: Provide resilient plastic or rubber accessory to secure flexible flashing in reglet where clearance does not permit use of standard metal counterflashing or where Drawings show reglet without metal counterflashing.
 - b. Counterflashing Wind-Restraint Clips: Provide clips to be installed before counterflashing to prevent wind uplift of counterflashing lower edge.
 - 6. Finish: Mill.

2.6 FABRICATION, GENERAL

- A. Custom fabricate sheet metal flashing and trim to comply with details shown and recommendations in cited sheet metal standard that apply to design, dimensions, geometry, metal thickness, and other characteristics of item required.
 - 1. Shop-fabricate sheet metal flashing and trim to greatest extent possible.

**NISQUALLY STATE PARK
NEW FULL SERVICE PARK – PHASE 2**

2. Fabricate sheet metal flashing and trim in thickness or weight needed to comply with performance requirements, but not less than that specified for each application and metal.
 3. Obtain field measurements for accurate fit before shop fabrication.
 4. Form sheet metal flashing and trim to fit substrates without excessive oil canning, buckling, and tool marks; true to line, levels, and slopes; and with exposed edges folded back to form hems.
 5. Conceal fasteners and expansion provisions where possible.
 - a. Do not use exposed fasteners on faces exposed to view.
- B. Fabrication Tolerances: Fabricate sheet metal flashing and trim that is capable of installation to a tolerance of 1/4 inch in 20 feet on slope and location lines indicated on Drawings and within 1/8 inch offset of adjoining faces and of alignment of matching profiles.
- C. Fabrication Tolerances: Fabricate sheet metal flashing and trim that is capable of installation to tolerances specified in MCA's "Guide Specification for Residential Metal Roofing."
- D. Expansion Provisions: Form metal for thermal expansion of exposed flashing and trim.
 1. Form expansion joints of intermeshing hooked flanges, not less than 1 inch deep, filled with butyl sealant concealed within joints.
 2. Use lapped expansion joints only where indicated on Drawings.
- E. Sealant Joints: Where movable, nonexpansion-type joints are required, form metal to provide for proper installation of elastomeric sealant according to cited sheet metal standard.
- F. Fabricate cleats and attachment devices from same material as accessory being anchored or from compatible, noncorrosive metal.
- G. Fabricate cleats and attachment devices of sizes as recommended by cited sheet metal standard for application, but not less than thickness of metal being secured.
- H. Seams:
 1. Fabricate nonmoving seams with flat-lock seams.
 - a. Form seams and seal with elastomeric sealant unless otherwise recommended by sealant manufacturer for intended use.
 - b. Rivet joints where necessary for strength.
- I. Do not use graphite pencils to mark metal surfaces.

2.7 ROOF-DRAINAGE SHEET METAL FABRICATIONS

- A. Hanging Gutters:
1. Fabricate to cross section indicated, complete with end pieces, outlet tubes, and other accessories as required.
 2. Fabricate in minimum 96 inch long sections.

**NISQUALLY STATE PARK
NEW FULL SERVICE PARK – PHASE 2**

3. Furnish flat-stock gutter brackets and gutter spacers and straps fabricated from same metal as gutters, of size recommended by cited sheet metal standard but with thickness not less than twice gutter thickness unless indicated otherwise.
 4. Fabricate expansion joints, expansion-joint covers, and gutter accessories from same metal as gutters.
 - a. Shop-fabricate interior and exterior corners.
 5. Gutter Profile: As indicated on Drawings.
 6. Expansion Joints: Butt type with cover plate.
 7. Gutters with Girth up to 15 inches: Fabricate from the following materials:
 - a. Aluminum-Zinc Alloy-Coated Steel: 0.022 inch thick.
- B. Downspouts:
1. Fabricate round downspouts, unless indicated otherwise, to dimensions indicated on Drawings, complete with mitered elbows.
 2. Fabricate downspouts from the following materials:
 - a. Aluminum-Zinc Alloy-Coated Steel: 0.0217 inch thick.
 3. Fabricate hangers from the following materials:
 - a. Aluminum-Zinc Alloy-Coated Steel: 0.108 inch thick.
 4. Downspout Boots: Contoured interior flow design with no boxed corners, weld seams or choke points; include integral lug slots and stainless steel fasteners
 - a. Material: Gray cast iron, ASTM A48, Class 30.
 - b. Configuration: Offset, angular, or 90-degree configuration as indicated on Drawings.
 - c. Finish: Manufacturer's standard powder coating in color to match downspouts.
 5. Downspout Connections to Storm Drainage System: As indicated on civil Drawings.
- C. Gutter Strainers:
1. Dome-shaped wire strainers in sizes and profiles to fit gutter outlet tubes.
 2. Material: 0.128 inch thick stainless steel wire.
 3. Provide with expansion anchor fitting for push-on pipe connections.
- D. Splash Pans: Prefinished steel to match other sheet metal flashing and trim.
1. Fabricate from the following material:
 - a. Galvanized Steel: 0.0336 inch thick.
 2. Fabricate to match SMACNA Figure 1-36. Verify with Architect prior to fabrication.
 3. Include elbow at downspout to direct water away from building.

**NISQUALLY STATE PARK
NEW FULL SERVICE PARK – PHASE 2**

- E. Splash Blocks: Precast concrete, top surface curbed on 3 sides, and sloped from back to front for proper drainage; with fabricator's standard reinforcing.
1. Size: 16 by 32 by 3-1/2 inches.
 2. Steel Bar Reinforcement: ASTM A615, Grade 60, deformed. Use hot-dip galvanized steel where concrete coverage will be less than 2 inches.
 3. Exposed Surface Finish: Smooth form finish. Comply with ACI 301.
 4. Color: Natural, consistent in color.
 5. Concrete Design Mix: Not less than 3,000 psi, in place, at 28 days.
 6. Air-Entraining Admixture: As recommended by splash block manufacturer to achieve minimum of 5 percent air content.
 - a. Do not use calcium chloride or fly ash.

2.8 LOW-SLOPE ROOF SHEET METAL FABRICATIONS

- A. Roof Edge Flashing (Gravel Stop): Fabricate in minimum 96 inch long, but not exceeding 12 footlong sections. Furnish with 6 inch wide, joint cover plates. Shop fabricate interior and exterior corners.
1. Joint Style: Butted with expansion space and 6 inch wide, concealed backup plate.
 2. Fabricate from the following materials:
 - a. Aluminum-Zinc Alloy-Coated Steel: 0.0276 inch thick.
- B. Roof-to-Wall Transition Expansion-Joint Cover: Fabricate from the following materials:
1. Aluminum-Zinc Alloy-Coated Steel: 0.0336 inch thick.
- C. Base Flashing: Fabricate from the following materials:
1. Galvanized Steel: 0.0276 inch thick.
- D. Counterflashing: Fabricate from the following materials:
1. Galvanized Steel: 0.0217 inch thick.
- E. Flashing Receivers: Fabricate from the following materials:
1. Galvanized Steel: 0.0217 inch thick.
- F. Roof-Penetration Flashing: Fabricate from the following materials:
1. Stainless Steel: 0.0188 inch thick.

2.9 WALL SHEET METAL FABRICATIONS

- A. Through-Wall Flashing: Fabricate continuous flashings in minimum 96 inch long, but not exceeding 12 foot long, sections, under copings, and at shelf angles. Fabricate discontinuous lintel, sill, and

**NISQUALLY STATE PARK
NEW FULL SERVICE PARK – PHASE 2**

similar flashings to extend 6 inches beyond each side of wall openings; and form with 2 inch high end dams. Fabricate from the following materials:

1. Stainless Steel: 0.025 inch thick.
- B. Opening Flashings in Frame Construction: Fabricate head, sill, jamb, and similar flashings to extend 4 inches beyond wall openings. Form head and sill flashing with 2 inch high end dams. Fabricate from the following materials:
1. Stainless Steel: 0.025 inch thick.

PART 3 - EXECUTION

3.1 ACCEPTABLE FABRICATORS

- A. Contractor's option to provide shop-fabricated metal copings. Fabricate and install copings according to SPRI ES-1 requirements.

3.2 EXAMINATION

- A. Examine substrates, areas, and conditions, with Installer present, for compliance with requirements for installation tolerances, substrate, and other conditions affecting performance of Work.
1. Verify compliance with requirements for installation tolerances of substrates.
 2. Verify that substrate is sound, dry, smooth, clean, sloped for drainage, and securely anchored.
 3. Verify that air- or water-resistant barriers have been installed over sheathing or backing substrate to prevent air infiltration or water penetration.
- B. Proceed with installation only after unsatisfactory conditions have been corrected.

3.3 INSTALLATION OF UNDERLAYMENT

- A. Underlayments: Install underlayment materials to comply with requirements specified in Section 073013 – Roofing Underlayments.

3.4 INSTALLATION OF SHEET METAL, GENERAL

- A. Anchor sheet metal flashing and trim and other components of Work securely in place, with provisions for thermal and structural movement. Use fasteners, solder, protective coatings, separators, sealants, and other miscellaneous items as required to complete sheet metal flashing and trim system.
1. Install sheet metal flashing and trim true to line, levels, and slopes. Provide uniform, neat seams with minimum exposure of solder, welds, and sealant.
 2. Install sheet metal flashing and trim to fit substrates and to result in watertight performance. Verify shapes and dimensions of surfaces to be covered before fabricating sheet metal.

**NISQUALLY STATE PARK
NEW FULL SERVICE PARK – PHASE 2**

3. Space cleats not more than 12 inches apart. Attach each cleat with at least 2 fasteners. Bend tabs over fasteners.
 4. Install exposed sheet metal flashing and trim with limited oil canning, and free of buckling and tool marks.
 5. Torch cutting of sheet metal flashing and trim is not permitted.
 6. Do not use graphite pencils to mark metal surfaces.
- B. Metal Protection: Where dissimilar metals contact each other, or where metal contacts pressure-treated wood or other corrosive substrates, protect against galvanic action or corrosion by painting contact surfaces with bituminous coating or by other permanent separation as recommended by sheet metal manufacturer or cited sheet metal standard.
1. Coat concealed side of uncoated stainless-steel sheet metal flashing and trim with bituminous coating where flashing and trim will contact wood, ferrous metal, or cementitious construction.
- C. Expansion Provisions: Provide for thermal expansion of exposed flashing and trim. Space movement joints at maximum of 10 feet with no joints within 24 inches of corner or intersection.
1. Form expansion joints of intermeshing hooked flanges, not less than 1 inch deep, filled with sealant concealed within joints.
 2. Use lapped expansion joints only where indicated on Drawings.
- D. Fasteners: Use fastener sizes that penetrate substrate not less than recommended by fastener manufacturer to achieve maximum pull-out resistance.
- E. Conceal fasteners and expansion provisions where possible in exposed Work and locate to minimize possibility of leakage. Cover and seal fasteners and anchors as required for a tight installation.
- F. Seal joints as required for watertight construction.
1. Use sealant-filled joints unless otherwise indicated.
 - a. Embed hooked flanges of joint members not less than 1 inch into sealant.
 - b. Form joints to completely conceal sealant.
 - c. When ambient temperature at time of installation is between 40 and 70 d F, set joint members for 50 percent movement each way.
 - d. Adjust setting proportionately for installation at higher ambient temperatures.
 - 1) Do not install sealant-type joints at temperatures below 40 deg F.
 2. Prepare joints and apply sealants to comply with requirements in Section 079200 – Joint Sealants.
- G. Soldered Joints: Clean surfaces to be soldered, removing oils and foreign matter. Pre-tin edges of sheets with solder to width of 1-1/2 inches; however, reduce pre-tinning where pre-tinned surface would show in completed Work.
1. Do not solder metallic-coated steel and aluminum sheet.
 2. Do not use torches for soldering.

**NISQUALLY STATE PARK
NEW FULL SERVICE PARK – PHASE 2**

3. Heat surfaces to receive solder, and flow solder into joint. Fill joint completely. Completely remove flux and spatter from exposed surfaces.
 4. Stainless-Steel Soldering:
 - a. Tin edges of uncoated sheets using solder recommended for stainless steel and acid flux.
 - b. Promptly remove acid flux residue from metal after tinning and soldering.
 - c. Comply with solder manufacturer's recommended methods for cleaning and neutralization.
- H. Rivets: Rivet joints in uncoated aluminum where necessary for strength.

3.5 INSTALLATION OF ROOF-DRAINAGE SYSTEM

- A. Install sheet metal roof-drainage items to produce complete roof-drainage system according to cited sheet metal standard unless otherwise indicated. Coordinate installation of roof perimeter flashing with installation of roof-drainage system.
- B. Hanging Gutters: Join sections with riveted and soldered joints or joints sealed with sealant. Provide for thermal expansion. Attach gutters at eave or fascia to firmly anchor them in position. Provide end closures and seal watertight with sealant. Slope to downspouts.
1. Anchor gutter with gutter brackets spaced not more than 18 inches apart to roof deck, unless otherwise indicated, and loosely lock to front gutter bead.
 2. Install gutter with expansion joints at locations indicated, but not exceeding, 50 feet apart. Install expansion-joint caps.
- C. Metal Downspouts:
1. Connect downspout to gutter outlet tubes, and fasten as recommended by Installer.
 2. Join sections with 1-1/2- inch telescoping joints.
 3. Attach downspouts to wall with fasteners designed to hold downspouts securely in place.
 - a. Locate hangers at top and bottom and at approximately 60 inches on center.
 - b. Design anchors and brackets to allow removal of downspouts without damage to downspouts and brackets.
 4. Connect downspouts to underground drainage system or provide elbows at base of downspout to direct water away from building, as indicated on Drawings.
- D. Expansion-Joint Covers:
1. Install expansion-joint covers at locations and of configuration indicated.
 2. Lap joints minimum of 4 inches in direction of water flow.
- E. Splash Pans: Install where downspouts discharge on low-slope roofs.
1. Set in adhesive material compatible with substrate material.
- F. Splash Blocks: Install where downspouts discharge on grade and where else indicated.

**NISQUALLY STATE PARK
NEW FULL SERVICE PARK – PHASE 2**

- G. Install gutter strainers at openings of each gutter conductor head outlet tube.

3.6 INSTALLATION OF ROOF FLASHING

- A. Install sheet metal flashing and trim to comply with performance requirements, sheet metal manufacturer's written installation instructions, and cited sheet metal standard.
 - 1. Provide concealed fasteners where possible, and set units true to line, levels, and slopes.
 - 2. Install Work with laps, joints, and seams that are permanently watertight and weather resistant.
- B. Roof Edge Flashing: Anchor to resist uplift and outward forces according to recommendations in cited sheet metal standard unless otherwise indicated. Interlock bottom edge of roof edge flashing with continuous cleat anchored to substrate at staggered 3 inch centers.
- C. Pipe or Post Counterflashing: Install counterflashing umbrella with close-fitting collar with top edge flared for elastomeric sealant, extending minimum of 4 inches over base flashing. Install stainless-steel draw band and tighten.
- D. Counterflashing: Coordinate installation of counterflashing with installation of base flashing.
 - 1. Insert counterflashing in reglets or receivers and fit tightly to base flashing.
 - 2. Extend counterflashing inches over base flashing.
 - 3. Lap counterflashing joints a minimum of 4 inches.
 - 4. Secure in a waterproof manner by means of snap-in installation and sealant or lead wedges and sealant, or interlocking folded seam or blind rivets and sealant unless indicated otherwise.
- E. Roof-Penetration Flashing:
 - 1. Coordinate installation of roof-penetration flashing with installation of roofing and other items penetrating roof.
 - 2. Seal with butyl sealant and clamp flashing to pipes that penetrate roof.

3.7 INSTALLATION OF WALL FLASHING

- A. Install sheet metal wall flashing to intercept and exclude penetrating moisture according to cited sheet metal standard unless otherwise indicated.
 - 1. Coordinate installation of wall flashing with installation of wall-opening components such as windows, doors, and louvers.
 - 2. Coordinate installation of wall flashing with requirements specified in Section 076500 – Flexible Flashings.
- B. Opening Flashings in Frame Construction: Install continuous head, sill, jamb, and similar flashings to extend 4 inches beyond wall openings.
- C. Reglets: Install reglets and counterflashing where indicated following manufacturer's written instructions for specific conditions.

**NISQUALLY STATE PARK
NEW FULL SERVICE PARK – PHASE 2**

3.8 ERECTION TOLERANCES

- A. Installation Tolerances: Shim and align sheet metal flashing and trim within installed tolerance of 1/4 inch in 20 feet on slope and location lines indicated on Drawings and within 1/8 inch offset of adjoining faces and of alignment of matching profiles.
- B. Installation Tolerances: Shim and align sheet metal flashing and trim within installed tolerances specified in MCA's "Guide Specification for Residential Metal Roofing."

3.9 REPAIR

- A. Replace sheet metal flashing and trim that have been damaged or that have deteriorated beyond successful repair by finish touchup or similar minor repair procedures, as determined by Architect.

3.10 CLEANING

- A. On completion of sheet metal flashing and trim installation, remove unused materials and clean finished surfaces as recommended in writing by sheet metal flashing and trim manufacturer.
 - 1. Clean exposed metal surfaces of substances that interfere with uniform oxidation and weathering.
 - 2. Clean and neutralize flux materials.
 - 3. Clean off excess solder.
 - 4. Clean off excess sealants.

3.11 PROTECTION

- A. Remove temporary protective coverings and strippable films as sheet metal flashing and trim are installed unless otherwise indicated in manufacturer's written installation instructions.
- B. Maintain sheet metal flashing and trim in clean condition during construction.

END OF SECTION

**NISQUALLY STATE PARK
NEW FULL SERVICE PARK – PHASE 2**

SECTION 076500 – FLEXIBLE FLASHING

PART 1 - GENERAL

1.1 SUMMARY

A. Section Includes:

1. Laminated flexible flashing.
2. Adhered sheet flexible flashing.

1.2 ACTION SUBMITTALS

A. Product Data: For each type of product.

1.3 INFORMATIONAL SUBMITTALS

A. Evaluation Reports: For water-resistive barrier and flexible flashing, from ICC-ES.

1.4 QUALITY ASSURANCE

A. Fire-Test-Response Characteristics: For assemblies with fire-resistance ratings, provide materials and construction identical to those of assemblies tested for fire resistance per ASTM E119 by testing and inspecting agency acceptable to authorities having jurisdiction.

1.5 WARRANTY

A. Manufacturer's Product Warranty: To repair or replace weather barrier product that fails in materials within specified warranty period.

1. Warranty Period: 10 years from date of Substantial Completion.

PART 2 - PRODUCTS

2.1 LAMINATED FLEXIBLE FLASHING

A. Stainless Steel Fabric Flashing (LM.FLSHG-1): Stainless steel core with polymer fabric laminated to bottom face with non-asphaltic adhesive.

1. Products: Subject to compliance with requirements, provide 1 of the following:

- a. Hohmann & Barnard, Inc.: Mighty-Flash.

**NISQUALLY STATE PARK
NEW FULL SERVICE PARK – PHASE 2**

- b. PROSOCO, Inc.: R-Guard SS.
 - c. STS Coatings, Inc.: Wall Guardian Self Adhering Stainless Steel Flashing.
 - d. York Manufacturing, Inc.: Multi-Flash SS.
2. Physical and Performance Properties:
- a. Stainless Steel Sheet: ASTM A240 or ASTM A666, Type 304.
 - b. Outer Layers: Polyethylene film or glass-fiber cloth bonded to 1 side of stainless steel sheet.
 - c. Recycled Content: Minimum 90 percent.
 - d. Fire Resistance: ASTM E84; Class B.
 - e. Puncture Resistance: ASTM E154; 780 lbf minimum.
 - f. Tensile Strength: ASTM D412; 32,000 psi minimum.
 - g. Fungal Resistance: ASTM D3273; passes.
3. Applications: Through-wall flashing that is fully concealed from view.
- B. Aluminum-Faced, Modified Bituminous Transition Membrane (LM.FLSHG-3): UV-resistant, self-adhering, water-resistive membrane consisting of rubberized asphalt laminated to a cross-laminated polyethylene film faced with aluminum foil on exposed face and release liner on adhesive side.
1. Products: Subject to compliance with requirements, provide one of the following:
- a. GCP Applied Technologies Inc.: Perm-A-Barrier Aluminum Flashing.
 - b. Henry Company: Blueskin Metal Clad.
 - c. Protecto Wrap: Protecto Seal 45.
 - d. Soprema: Soprasolin HD.
 - e. W.R. Meadows, Inc.: Air-Shield Aluminum Flashing.
 - f. Approved substitution.
2. Thickness: 0.040 inch (40 mils).
3. Physical and Performance Properties:
- a. Air Permeance: Maximum 0.004 cfm/sq. ft. of surface area at 1.57-lbf/sq. ft. pressure difference; ASTM E2178.
 - b. Tensile Strength: Minimum 250 psi; ASTM D412, Die C.
 - c. Ultimate Elongation: Minimum 80 percent; ASTM D412, Die C.
 - d. Puncture Resistance: Minimum 40 lbf; ASTM E154.
 - e. Water Absorption: Maximum 0.15 percent weight gain after 48-hour immersion at 70 deg F; ASTM D570.
 - f. Vapor Permeance: Maximum 0.1 perm; ASTM E96, Desiccant Method.
 - g. Adhesion to Substrate: Minimum 16 lbf/sq. in. when tested according to ASTM D4541 as modified by ABAA.
 - h. Fire Propagation Characteristics: Passes NFPA 285 testing as part of an approved assembly.
 - i. UV Resistance: Can be exposed to sunlight for 360 days according to manufacturer's written instructions.
4. Applications: Transitions between self-adhering sheet SAAB.VP air and water resistive barrier systems and waterproofing systems.

**NISQUALLY STATE PARK
NEW FULL SERVICE PARK – PHASE 2**

2.2 ADHERED SHEET FLEXIBLE FLASHING

A. Rubberized-Asphalt Transition Membrane (SA.FLSHG-2): Composite flashing product consisting of a pliable, adhesive, rubberized-asphalt compound, bonded to a high-density, cross-laminated polyethylene film:

1. Products: Subject to compliance with requirements, provide 1 of the following:
 - a. Henry Company: Blueskin SA.
 - b. SIGA Cover Inc.: SIGA Majvest 500 SA.
 - c. VaproShield LLC: WrapShield SA.
 - d. W. R. Meadows, Inc.: Air-Shield 25 mil Flashing Tape.
 - e. York Manufacturing, Inc.: York Seal Flashing.
 - f. Approved substitution.
2. Overall Thickness: Not less than 0.040 inch.
3. Accessories: Provide preformed corners, end dams, other special shapes, and seaming materials produced by flashing manufacturer.
4. Applications: Interface with self-adhering sheet (SAAB.VP) air and water resistive barrier systems, including at rough openings.

B. Rubberized-Asphalt Thru-Wall Flashing (SA.FLSHG-3): Composite flashing product consisting of a pliable, adhesive, rubberized-asphalt compound, bonded to a high-density, cross-laminated polyethylene film:

1. Products: Subject to compliance with requirements, provide 1 of the following:
 - a. Heckmann Building Products Inc.: No. 82 Rubberized-Asphalt Thru-Wall Flashing.
 - b. Henry Company: Blueskin TWF Self-Adhered Thru-Wall Flashing.
 - c. Hohmann & Barnard, Inc.: Textroflash.
 - d. Tremco, Inc.: ExoAir TWF Thru-Wall Flashing.
 - e. VaproShield LLC: VaproFlashing SA.
 - f. W. R. Meadows, Inc.: Air-Shield Thru-Wall Flashing.
 - g. Wire-Bond: Aqua Flash 500.
 - h. York Manufacturing, Inc.: York Seal Flashing.
 - i. Approved substitution.
2. Overall Thickness: Not less than 0.040 inch.
3. Applications: Embedded through-wall flashing in unit masonry and in masonry veneer.
 - a. Do not use copper flashing where flashing is partly exposed.

C. Self-Adhering, High Temperature Flashing (SA.FLSHG-6): Sheet flashing made from slip-resistant, polyethylene-film top surface laminated to a layer of SBS-modified asphalt adhesive, with release-paper backing.

1. Products: Subject to compliance with requirements, provide one of the following:
 - a. Carlisle Coatings & Waterproofing Inc.: WIP 300HT.
 - b. CertainTeed Corporation: WinterGuard HT.

**NISQUALLY STATE PARK
NEW FULL SERVICE PARK – PHASE 2**

- c. GCP Applied Technologies Inc.: Grace Ice and Water Shield HT.
 - d. Henry Company: Blueskin PE200 HT.
 - e. Approved substitution.
2. Physical Properties:
- a. Thickness: Minimum of 40 mils.
 - b. Service Temperature: Minimum 230 deg F.
 - c. Thermal Stability: ASTM D1970, stable after testing at 240 deg F.
 - d. Low-Temperature Flexibility: ASTM D1970; passes after testing at minus 20 deg F.
 - e. Vapor Permeance: 0.01 perms; ASTM E96.
 - f. Allowable UV Exposure Time: Not less than 180 days.
3. Provide primer when recommended by underlayment manufacturer.
4. Applications: Flashing under sheet metal copings.

2.3 ACCESSORIES

- A. Primer for Flexible Flashing: Product recommended in writing by flexible flashing manufacturer for substrate.
- B. Joint Reinforcing Strip: Manufacturer's recommended woven polyester or fiberglass mesh.
 - 1. Minimum Thickness: 30 mils.
- C. Nails and Staples: Product recommended in writing by flexible flashing manufacturer and complying with ASTM F1667.

PART 3 - EXECUTION

3.1 INSTALLATION OF FLEXIBLE FLASHING

- A. Apply flexible flashing where indicated to comply with manufacturer's written instructions.
 - 1. Prime substrates as recommended by flashing manufacturer.
 - 2. Lap seams and junctures with other materials at least 8 inches except that at flashing flanges of other construction, laps need not exceed flange width.
 - 3. Lap flashing over water-resistive barrier at bottom and sides of openings.
 - 4. Lap water-resistive barrier over flashing at heads of openings.
 - 5. After flashing has been applied, roll surfaces with a hard rubber or metal roller to ensure that flashing is completely adhered to substrates.

END OF SECTION

**NISQUALLY STATE PARK
NEW FULL SERVICE PARK – PHASE 2**

SECTION 079200 – JOINT SEALANTS

PART 1 - GENERAL

1.1 SUMMARY

A. Section Includes:

1. Silicone joint sealants.
2. Urethane joint sealants.
3. Silyl-terminated polymer (STP) joint sealants.
4. Butyl joint sealants.
5. Latex joint sealants.
6. Joint sealant backing.

1.2 ADMINISTRATIVE REQUIREMENTS

- A. Preinstallation Meetings: Conduct meeting at Project site.

1.3 ACTION SUBMITTALS

- A. Product Data: For each joint-sealant product.

- B. Samples for Verification: For each kind and color of joint sealant required, provide Samples with joint sealants in 1/2 inch wide joints formed between two 6 inch long strips of material matching appearance of exposed surfaces adjacent to joint sealants.

- C. Sealant Schedule: Submit schedule of sealant applications listing joint sealants proposed for this Work and materials to which joint sealants are specified to be applied.

1. Obtain Architect's written approval of sealant schedule before starting Work of this Section.
2. Joint-Sealant Schedule: Include the following information:
 - a. Joint-sealant application, joint location, and designation.
 - b. Joint-sealant manufacturer and product name.
 - c. Joint-sealant formulation.
 - d. Joint-sealant color.

1.4 INFORMATIONAL SUBMITTALS

- A. Qualification Data: For qualified testing agency.

- B. Product Test Reports: For each kind of joint sealant, for tests performed by manufacturer and witnessed by qualified testing agency. Include the following information for each joint sealant and substrate material to be tested:

**NISQUALLY STATE PARK
NEW FULL SERVICE PARK – PHASE 2**

1. Joint-sealant location and designation.
 2. Manufacturer and product name.
 3. Type of substrate material.
 4. Proposed test.
 5. Number of samples required.
- C. Preconstruction Laboratory Test Reports: From sealant manufacturer, indicating the following:
1. Materials forming joint substrates and joint-sealant backings have been tested for compatibility and adhesion with joint sealants.
 2. Interpretation of test results and written recommendations for primers and substrate preparation are needed for adhesion.
- D. Sealant, Waterproofing, and Restoration Institute (SWRI) Validation Certificate: For each sealant specified to be validated by SWRI's Sealant Validation Program.
- E. Sample Warranties: For special warranties.
- 1.5 QUALITY ASSURANCE
- A. Installer Qualifications: An entity that employs installers who are trained and approved by sealant manufacturer with a minimum 5 years of documented experience performing work similar in scale and scope to this Project.
1. Single Source Responsibility: Provide field-installation of exterior joint sealers specified in this Section under responsibility of a single installer.
- B. Testing Agency Qualifications: Qualified according to ASTM C1021 to conduct testing indicated.
- C. Product Testing: Test joint sealants using a qualified testing agency.
1. Test according to SWRI's Sealant Validation Program for compliance with requirements specified by reference to ASTM C920 for adhesion and cohesion under cyclic movement, adhesion-in-peel, and indentation hardness.
- D. Mockups:
1. Install sealants in mockups of assemblies specified in other Sections that are indicated to receive joint sealants specified in this Section. Use materials and installation methods specified in this Section.
 2. Conduct mockups of joint sealing systems specified in this Section as part of system mockups as specified by related Sections for purpose of verifying visual appearance, water and air infiltration testing, conducting pull tests to determine correct use of cleaning and primers, and to aid in determining general adequacy of system design.
 3. Include concrete systems, wall cladding, roofing and waterproofing systems, and window systems.
 4. Include system components including backing materials and bond breakers.
 5. Verify need for primers and other preinstallation preparation for each surface.
 6. Inspect mockups after 14 days and perform pull test under supervision of manufacturer's representative to determine suitability and primer requirements.

**NISQUALLY STATE PARK
NEW FULL SERVICE PARK – PHASE 2**

7. Adjust as needed for acceptance conforming to manufacturer's instructions and provisions of Contract Documents.
8. Protect accepted mockup as quality standard for Work of this Section.

1.6 PRECONSTRUCTION TESTING

- A. Preconstruction Laboratory Testing: Submit to joint-sealant manufacturers, for testing indicated below, samples of materials that will contact or affect joint sealants.
1. Adhesion Testing: Use ASTM C794 to determine whether priming and other specific joint preparation techniques are required to obtain rapid, optimum adhesion of joint sealants to joint substrates.
 2. Compatibility Testing: Use ASTM C1087 to determine sealant compatibility when in contact with glazing and gasket materials.
 3. Stain Testing: Use ASTM C1248 to determine stain potential of sealant when in contact with masonry substrates.
 4. Submit manufacturer's recommended number of pieces of each type of material, including joint substrates, joint-sealant backings, and miscellaneous materials.
 5. Schedule sufficient time for testing and analyzing results to prevent delaying Work.
 6. For materials failing tests, obtain joint-sealant manufacturer's written instructions for corrective measures, including use of specially formulated primers.
 7. Testing will not be required if joint-sealant manufacturers submit data that are based on previous testing, not older than 24 months, of sealant products for adhesion to, staining of, and compatibility with joint substrates and other materials matching those submitted.

1.7 FIELD CONDITIONS

- A. Do not proceed with installation of joint sealants under the following conditions:
1. When ambient and substrate temperature conditions are outside limits permitted by joint-sealant manufacturer or are below 40 deg F.
 2. When joint substrates are wet.
 3. Where joint widths are less than those allowed by joint-sealant manufacturer for applications indicated.
 4. Where contaminants capable of interfering with adhesion have not yet been removed from joint substrates.

1.8 WARRANTY

- A. Special Installer's Warranty: Installer agrees to repair or replace joint sealants that do not comply with performance and other requirements specified in this Section within specified warranty period.
1. Warranty Period: 5 years from date of Substantial Completion.

**NISQUALLY STATE PARK
NEW FULL SERVICE PARK – PHASE 2**

- B. Special Manufacturer's Warranty: Manufacturer agrees to furnish joint sealants to repair or replace those joint sealants that do not comply with performance and other requirements specified in this Section within specified warranty period.
 - 1. Warranty Period: 5 years from date of Substantial Completion.
- C. Special warranties specified in this Article exclude deterioration or failure of elastomeric joint sealants from the following:
 - 1. Movement of structure caused by stresses on sealant exceeding sealant manufacturer's written specifications for sealant elongation and compression.
 - 2. Disintegration of joint substrates from natural causes exceeding design specifications.
 - 3. Mechanical damage caused by individuals, tools, or other outside agents.
 - 4. Changes in sealant appearance caused by accumulation of dirt or other atmospheric contaminants.

PART 2 - PRODUCTS

2.1 JOINT SEALANTS, GENERAL

- A. Provide joint sealants, backings, and other related materials that are compatible with one another and with joint substrates under conditions of service and application, as demonstrated by joint-sealant manufacturer, based on testing and field experience.
- B. Colors of Exposed Joint Sealants: As selected by Architect from manufacturer's full range.
 - 1. Where color is indicated to “match adjacent substrates” or “match existing,” provide either manufacturer’s standard color if matching color is available, or, if not available, provide field-tintable custom color.

2.2 SILICONE JOINT SEALANTS

- A. Silicone (SLNT-S1): Single-component, nonstaining, nonsag, nontraffic-use, neutral-curing silicone joint sealant.
 - 1. Products: Subject to compliance with requirements, provide one of the following:
 - a. Dow Chemical Company: Dowsil 795.
 - b. GE Silicones: GE SCS9000 Silpruf NB.
 - c. Pecora Corporation: 864NST.
 - d. Sika Corporation: Sikasil WS-295.
 - e. Tremco Incorporated: Spectrem 3.
 - 2. Compliance: ASTM C 920, Type S, Grade NS, Class 50, Use NT, G, A, and O.
 - 3. Staining: ASTM C1248; no staining on concrete, marble, granite, limestone, and brick.
 - 4. Color: As selected by Architect from manufacturer's full color range.

**NISQUALLY STATE PARK
NEW FULL SERVICE PARK – PHASE 2**

B. Silicone (SLNT-S2): Single-component, nonsag, nontraffic-use, neutral-curing silicone joint sealant.

1. Products: Subject to compliance with requirements, provide one of the following:

- a. Dow Chemical Company: Dowsil 790 Silicone Building Sealant.
- b. GE Silicones: GE SCS2700 SilPruf LM.
- c. Pecora Corporation: 890NST.
- d. Sika Corporation: Sikasil WS-290.
- e. Tremco Incorporated: Spectrem 1.

2. Compliance: ASTM C920, Type S, Grade NS, Class 100/50, Use NT.

3. Color: As selected by Architect from manufacturer's full color range.

C. Silicone, Mildew Resistant (SLNT-S3): Single-component, mildew-resistant, nonsag, nontraffic-use, acid-curing silicone joint sealant, USDA or NSF approved; formulated for prolonged exposure to humidity with fungicide to prevent mold and mildew growth.

1. Products: Subject to compliance with requirements, provide one of the following:

- a. Dow Chemical Company: Dowsil 786.
- b. GE Silicones: GE SCS1700 Sanitary.
- c. Pecora Corporation: 898NST Sanitary Silicone.
- d. Sika Corporation: Sikasil-N Plus US.
- e. Tremco Incorporated: Tremsil 200.

2. Compliance: ASTM C920, Type S, Grade NS, Class 25, Use NT.

3. Color: Translucent unless indicated otherwise.

D. Silicone (SLNT-S4): Single-component, neutral-curing, nonsag, nontraffic-use sealant.

1. Products: Subject to compliance with requirements, provide one of the following:

- a. Dow Chemical Company: Dowsil 758 Silicone Weather Barrier Sealant.
- b. GE Silicones: SCS2350.
- c. Pecora Corporation: ABV Silicone.
- d. Sika Corporation: Sikasil-N Plus US.

2. Compliance: ASTM C920, Type S, Grade NS, Class 25, Use NT.

3. Color: As selected by Architect from manufacturer's full color range.

2.3 URETHANE JOINT SEALANTS

A. Urethane (SLNT-U1): Single-component, pourable, traffic- and nontraffic-use, urethane joint sealant.

1. Products: Subject to compliance with requirements, provide one of the following:

- a. Master Builders Solutions: MasterSeal SL 1.
- b. Pecora Corporation: Urexpan NR-201.
- c. Polymeric Systems, Inc.: Flexiprene PSI-952.

**NISQUALLY STATE PARK
NEW FULL SERVICE PARK – PHASE 2**

- d. Sherwin-Williams Company (The): Loxon SL1.
 - e. Sika Corporation: Sikaflex 1c SL.
 - f. Tremco Incorporated: Vulkem 45SSL.
 - g. W. R. Meadows, Inc.: Pourthane SL.
 - 2. Compliance: ASTM C920, Type S, Grade P, Class 25, Uses T, M, A, and O.
 - B. Urethane (SLNT-U2): Multicomponent, chemical-curing, immersible, pourable, traffic- and nontraffic-use, urethane joint sealant.
 - 1. Products: Subject to compliance with requirements, provide one of the following:
 - a. Master Builders Solutions: MasterSeal SL 2.
 - b. Pecora Corporation: DynaTrol II-SG.
 - c. Sherwin-Williams Company (The): Loxon SL2.
 - d. Sika Corporation: Sikaflex 2c SL.
 - 2. Compliance: ASTM C920, Type M, Grade P, Class 25, Uses T, NT, and I.
 - 3. Color: Gray.
 - C. Urethane (SLNT-U3): Single-component, nonsag, nontraffic-use, urethane joint sealant.
 - 1. Products: Subject to compliance with requirements, provide one of the following:
 - a. Master Builders Solutions: MasterSeal CR 195.
 - b. Pecora Corporation: Dynatrol I-XL.
 - c. Polymeric Systems, Inc.: Flexiprene 1000.
 - d. Sherwin-Williams Company (The): Loxon S1.
 - e. Sika Corporation: Sikaflex 1a.
 - f. Tremco Incorporated: Dymonic 100.
 - g. W. R. Meadows, Inc.: Pourthane NS.
 - 2. Compliance: ASTM C920, Type S, Grade NS, Class 25/35/50, Use NT, G, M, A, and O.
- 2.4 SILYL-TERMINATED POLYMER (STPE OR STPU) HYBRID JOINT SEALANTS
- A. Hybrid, Mildew Resistant (SLNT-STP1): Single-component, mildew-resistant, nonsag, nontraffic-use, silyl-terminated polymer joint sealant, USDA or NSF approved; formulated for prolonged exposure to humidity with fungicide to prevent mold and mildew growth.
 - 1. Products: Subject to compliance with requirements, provide one of the following:
 - a. Master Builders Solutions: MasterSeal NP 150 or MasterSeal NP 100
 - b. Pecora Corporation: DynaTrol I-XL Hybrid.
 - c. Sherwin-Williams Company (The): Loxon H1.
 - d. Sika Corporation: SikaHyflex-150LM.
 - 2. Compliance: ASTM C920, Type S, Grade NS, Class 50, Use NT.
 - 3. Color: Translucent unless indicated otherwise.

**NISQUALLY STATE PARK
NEW FULL SERVICE PARK – PHASE 2**

- B. Hybrid (SLNT-STP2): Single-component, nonsag, nontraffic-use, silyl-terminated polymer joint sealant.
1. Products: Subject to compliance with requirements, provide one of the following:
 - a. Carlisle Coatings & Waterproofing Inc.: BarriBond.
 - b. Henry Company: 925 BES Sealant.
 - c. Polymeric Systems, Inc.: Sili-Thane 803.
 - d. Sto Corp: StoGuard RapidSeal.
 - e. TK Products Construction Coatings: Super Seal PE.
 - f. Tremco Incorporated: Dymonic FC.
 2. Compliance: ASTM C920, Type S, Grade NS, Class 25, Use NT.

2.5 BUTYL JOINT SEALANTS

- A. Butyl-Rubber-Based Joint Sealant (SLNT-BR1) : ASTM C1311; single-component, solvent-release butyl rubber sealant; polyisobutylene plasticized; heavy bodied for joints with limited movement.
1. Products: Subject to compliance with requirements, provide one of the following:
 - a. Pecora Corporation: BC-158.
 - b. Premier Building Solutions: XtraBond 1500.
 - c. Sika Corporation: SikaLastomer-511.
 - d. Tremco Incorporated: Tremco Butyl Sealant.
 2. Compliance: ASTM C1311, Class 12-1/2.
 3. Performance Requirements:
 - a. Movement Capability: Plus/minus 12-1/2 percent.
 - b. Service Temperature Range: 13 to 180 deg F.
 4. Color: Black.

2.6 LATEX JOINT SEALANTS

- A. Acrylic Latex (SLNT-AL1): Acrylic latex or siliconized acrylic latex, paintable after cure.
1. Products: Subject to compliance with requirements, provide one of the following
 - a. Master Builders Solutions: MasterSeal NP 520.
 - b. Pecora Corporation: AC-20+ Silicone.
 - c. Sherwin-Williams Company (The): 950A Siliconized Acrylic Latex Caulk.
 - d. Tremco Incorporated: Tremflex 834.
 2. Compliance: ASTM C834, Type OP, Grade NF.

**NISQUALLY STATE PARK
NEW FULL SERVICE PARK – PHASE 2**

3. Performance Requirements:
 - a. Movement Capability: Plus/minus 12-1/2 percent.
 - b. Service Temperature Range: 13 to 180 deg F.
4. Color: Match adjacent finish surfaces.

2.7 JOINT-SEALANT BACKING

- A. Joint Sealant Backing Material, General: Nonstaining; compatible with joint substrates, sealants, primers, and other joint fillers; as approved in writing by joint-sealant manufacturer, for joint applications indicated based on field experience and laboratory testing.
- B. Cylindrical Sealant Backings: ASTM C1330; any of the following types, as approved in writing by joint-sealant manufacturer for joint application indicated, and of size and density to control sealant depth and otherwise contribute to producing optimum sealant performance.
 1. Type B (Bicellular Material with Surface Skin):
 - a. Applications: Interior and exterior joints subject to pedestrian or vehicular traffic, expansion and contraction joints, window glazing, curtain walls, perimeter of window, door, louver, and other metal frames.
 2. Type C (Closed-Cell Material with Surface Skin):
 - a. Applications: Exterior joints subject to pedestrian or vehicular traffic, expansion and contraction joints, window glazing, curtain walls, precast concrete, pavement, parking decks, and metal copings.
 3. Type O (Open-Cell Material):
 - a. Application: Interior and exterior vertical surfaces. Do not use on horizontal surfaces. Not immersible.
- C. Bond-Breaker Tape: Polyethylene tape or other plastic tape recommended by sealant manufacturer for preventing sealant from adhering to rigid, inflexible joint-filler materials or joint surfaces at back of joint. Provide self-adhesive tape where applicable.

2.8 MISCELLANEOUS MATERIALS

- A. Primer: Material recommended by joint-sealant manufacturer where required for adhesion of sealant to joint substrates indicated, as determined from preconstruction joint-sealant-substrate tests and field tests.
- B. Cleaners for Nonporous Surfaces: Chemical cleaners acceptable to manufacturers of sealants and sealant backing materials, free of oily residues or other substances capable of staining or harming joint substrates and adjacent nonporous surfaces in any way, and formulated to promote optimum adhesion of sealants to joint substrates.

**NISQUALLY STATE PARK
NEW FULL SERVICE PARK – PHASE 2**

- C. Masking Tape: Nonstaining, nonabsorbent material compatible with joint sealants and surfaces adjacent to joints.

PART 3 - EXECUTION

3.1 EXAMINATION

- A. Examine joints indicated to receive joint sealants, with Installer present, for compliance with requirements for joint configuration, installation tolerances, and other conditions affecting joint-sealant performance.
- B. Proceed with installation only after unsatisfactory conditions have been corrected.

3.2 PREPARATION

- A. Surface Cleaning of Joints: Clean out joints immediately before installing joint sealants to comply with joint-sealant manufacturer's written instructions and the following requirements:
 - 1. Remove foreign material from joint substrates that could interfere with adhesion of joint sealant, including dust, paints (except for permanent, protective coatings tested and approved for sealant adhesion and compatibility by sealant manufacturer), existing joint sealants, oil, grease, waterproofing, water repellents, water, surface dirt, and frost.
 - 2. Clean porous joint substrate surfaces by brushing, grinding, mechanical abrading, or a combination of these methods to produce a clean, sound substrate capable of developing optimum bond with joint sealants. Remove loose particles remaining after cleaning operations above by vacuuming or blowing out joints with oil-free compressed air.
 - 3. Remove laitance and form-release agents from concrete.
 - 4. Clean nonporous joint substrate surfaces with chemical cleaners or other means that do not stain, harm substrates, or leave residues capable of interfering with adhesion of joint sealants.
- B. Joint Priming: Prime joint substrates where recommended by joint-sealant manufacturer or as indicated by preconstruction joint-sealant-substrate tests or prior experience. Apply primer to comply with joint-sealant manufacturer's written instructions. Confine primers to areas of joint-sealant bond: do not allow spillage or migration onto adjoining surfaces.
- C. Masking Tape: Use masking tape where required to prevent contact of sealant or primer with adjoining surfaces that otherwise would be permanently stained or damaged by such contact or by cleaning methods required to remove sealant smears. Remove tape immediately after tooling without disturbing joint seal.

3.3 INSTALLATION OF JOINT SEALANTS

- A. Comply with joint-sealant manufacturer's written installation instructions for products and applications indicated unless more stringent requirements apply.
- B. Sealant Installation Standard: Comply with recommendations in ASTM C1193 for use of joint sealants as applicable to materials, applications, and conditions indicated.

**NISQUALLY STATE PARK
NEW FULL SERVICE PARK – PHASE 2**

- C. Install sealant backings of kind indicated to support sealants during application and at position required to produce cross-sectional shapes and depths of installed sealants relative to joint widths that allow optimum sealant movement capability.
 - 1. Install sealant backings at joint widths of 1/2 inch or more, and joint depths of 3/4 inch or more.
 - 2. Install sealant backings so that joint depth does not exceed 50 percent of joint width, unless otherwise recommended by sealant manufacturer.
 - 3. Do not leave gaps between ends of sealant backings.
 - 4. Do not stretch, twist, puncture, or tear sealant backings.
 - 5. Remove absorbent sealant backings that have become wet before sealant application and replace them with dry materials.

- D. Install bond-breaker tape behind sealants where sealant backings are not used between sealants and backs of joints.

- E. Install sealants using proven techniques that comply with the following and at same time backings are installed:
 - 1. Place sealants so they directly contact and fully wet joint substrates.
 - 2. Completely fill recesses in each joint configuration.
 - 3. Produce uniform, cross-sectional shapes and depths relative to joint widths that allow optimum sealant movement capability.

- F. Tooling of Nonsag Sealants: Immediately after sealant application and before skinning or curing begins, tool sealants per requirements specified in subparagraphs below to form smooth, uniform beads of configuration indicated; to eliminate air pockets; and to ensure contact and adhesion of sealant with sides of joint.
 - 1. Remove excess sealant from surfaces adjacent to joints.
 - 2. Use tooling agents that are approved in writing by sealant manufacturer and that do not discolor sealants or adjacent surfaces.
 - 3. Provide concave joint profile per Figure 8A in ASTM C1193, unless otherwise indicated.

3.4 FIELD QUALITY CONTROL

- A. Field-Adhesion Testing: Owner will engage qualified testing agency to field test joint-sealant adhesion to joint substrates as follows:
 - 1. Extent of Testing: Test completed and cured sealant joints as follows:
 - a. Perform 10 tests for the first 1,000 feet of joint length for each kind of sealant and joint substrate.
 - b. Perform 1 test for each 1,000 feet of joint length thereafter or 1 test per each floor per elevation.

**NISQUALLY STATE PARK
NEW FULL SERVICE PARK – PHASE 2**

2. Test Method: Test joint sealants per Method A, Field-Applied Sealant Joint Hand Pull Tab, in Appendix X1 in ASTM C1193 or Method A, Tail Procedure, in ASTM C1521.
 - a. For joints with dissimilar substrates, verify adhesion to each substrate separately: extend cut along one side, verifying adhesion to opposite side. Repeat procedure for opposite side.
 3. Inspect tested joints and report on the following:
 - a. Whether sealants filled joint cavities and are free of voids.
 - b. Whether sealant dimensions and configurations comply with specified requirements.
 - c. Whether sealants in joints connected to pulled-out portion failed to adhere to joint substrates or tore cohesively. Include data on pull distance used to test each kind of product and joint substrate. Compare these results to determine if adhesion passes sealant manufacturer's field-adhesion hand-pull test criteria.
 4. Record test results in a field-adhesion-test log. Include dates when sealants were installed, names of persons who installed sealants, test dates, test locations, whether joints were primed, adhesion results and percent elongations, sealant fill, sealant configuration, and sealant dimensions.
- B. Repair sealants pulled from test area by applying new sealants following same procedures used originally to seal joints. Ensure that original sealant surfaces are clean and that new sealant contacts original sealant.
- C. Evaluation of Field-Adhesion Test Results: Sealants not evidencing adhesive failure from testing or noncompliance with other indicated requirements will be considered satisfactory. Remove sealants that fail to adhere to joint substrates during testing or to comply with other requirements. Retest failed applications until test results prove sealants comply with indicated requirements.
- 3.5 CLEANING
- A. Clean off excess sealant or sealant smears adjacent to joints as Work progresses by methods and with cleaning materials approved in writing by manufacturers of joint sealants and of products in which joints occur.
- 3.6 PROTECTION
- A. Protect joint sealants during and after curing period from contact with contaminating substances and from damage resulting from construction operations or other causes so sealants are without deterioration or damage at time of Substantial Completion. If, despite such protection, damage or deterioration occurs, cut out and remove damaged or deteriorated joint sealants immediately so installations with repaired areas are indistinguishable from original Work.

**NISQUALLY STATE PARK
NEW FULL SERVICE PARK – PHASE 2**

3.7 EXTERIOR JOINT-SEALANT SCHEDULE

- A. Exterior joints in vertical surfaces and horizontal, nontraffic surfaces:
 - 1. Joint-Sealant SLNT-S1.
 - a. Joints between plastic wall panels.
 - b. Between hollow metal frames, aluminum storefront frames, and adjacent surfaces, except masonry.
 - c. Other joints as indicated Drawings.
 - 2. Joint-Sealant SLNT-U3.
 - a. Brick control, expansion, and soft joints.
 - b. Between brick and adjacent surfaces.
 - c. Between concrete and adjacent surfaces.
 - d. Joints in fiber cement siding systems.
 - e. Perimeter joints between metal frames and adjacent surfaces.
 - f. Perimeter joints between aluminum frames and adjacent surfaces.
 - g. Control and expansion joints in ceilings and other overhead surfaces.
 - h. Exterior joints for which no other sealant type is Indicated.
- B. Exterior joints in vertical surfaces not subject to significant movement.
 - 1. Joint-Sealant SLNT-AL1 or SLNT-STP2.
 - a. Perimeter joints between exterior wall surfaces and wood trim of doors and windows.
 - b. Perimeter joints between wood siding and metal frames of doors and windows.
- C. Exterior joints in horizontal traffic surfaces:
 - 1. Joint-Sealant SLNT-U2.
 - a. Isolation and contraction joints in cast-in-place concrete slabs.
 - b. Control and expansion joints in concrete paving.
 - c. Control and expansion joints for concrete sidewalks and other types of concrete construction.
 - d. Joints between different materials listed above.
 - e. Other joints as indicated on Drawings.
- D. Exterior concealed sealants.
 - 1. Joint-Sealant SLNT-S4 or SLNT-STP2.
 - a. Sealing of air barriers and weather-restive barriers.
- E. Exterior Concealed Mastics.
 - 1. Joint-Sealant SLNT-BR1.
 - a. Sheet metal flashing, metal Work, and other joints requiring nonhardening, nonskinning, non-drying, nonmigrating sealant.
 - b. Sealing seams of various sheet membranes, flashing, and roofing where indicated.

**NISQUALLY STATE PARK
NEW FULL SERVICE PARK – PHASE 2**

- c. Compression sealing where membrane is being terminated using a compression-type seal.
- d. Aluminum thresholds.
- e. Sill plates.
- f. Other locations indicated on Drawings where little or no movement is expected.

3.8 INTERIOR JOINT-SEALANT SCHEDULE

A. Interior joints in vertical surfaces and horizontal nontraffic surfaces:

- 1. Joint-Sealant SLNT-U3.
 - a. Tile control and expansion joints.
 - b. Other joints as indicated on Drawings.

B. Interior mildew-resistant joints in vertical surfaces and horizontal, nontraffic surfaces:

- 1. Joint-Sealant SLNT-S3 or SLNT-STP1.
 - a. Joints between plumbing fixtures and adjoining walls, floors, and counters, including countertops, vanities, tubs, showers, and other locations subject to moisture.
 - b. Tile flooring control and expansion joints that require compliance with USDA or NSF.
 - c. Other locations that require compliance with USDA or NSF.

C. Interior joints in vertical surfaces.

- 1. Joint-Sealant SLNT-S2.
 - a. Perimeter joints between wall surfaces and frames of doors, windows, and louvers in exterior walls.

D. Interior joints in horizontal traffic surfaces:

- 1. Joint-Sealant SLNT-U1.
 - a. Isolation joints in cast-in-place concrete slabs.
 - b. Tile flooring control and expansion joints where indicated.
 - c. Other joints as indicated on Drawings.

E. Interior joints in vertical surfaces and horizontal nontraffic surfaces not subject to significant movement.

- 1. Joint-Sealant SLNT-AL1 or SLNT-STP2.
 - a. Control joints on exposed interior gypsum board walls and ceilings.
 - b. Control joints on exposed interior surfaces of exterior walls.
 - c. Perimeter joints between interior wall surfaces and frames of interior doors, windows, and mechanical louvers in exterior walls.
 - d. Perimeter joints between interior wall surfaces and interior aluminum-framed storefront framing in exterior walls.

**NISQUALLY STATE PARK
NEW FULL SERVICE PARK – PHASE 2**

- e. Perimeter joints between interior wall surfaces and wood trim of interior doors and windows in exterior walls.
- f. Interior gypsum board abutments to adjacent surfaces.
- g. Perimeter of countertops at walls not subject to moisture.
- h. Other joints as indicated on Drawings.

END OF SECTION

**NISQUALLY STATE PARK
NEW FULL SERVICE PARK – PHASE 2**

SECTION 079219 – ACOUSTICAL JOINT SEALANTS

PART 1 - GENERAL

1.1 SUMMARY

A. Section Includes:

1. Acoustical joint sealants.

B. Related Requirements:

1. Section 079200 – Joint Sealants.

1.2 ACTION SUBMITTALS

A. Product Data: For each acoustical joint sealant.

B. Samples for Verification: For each kind and color of acoustical joint sealant required.

1. Size: 1/2 inchwide joints formed between two 6 inch long strips of material matching appearance of exposed surfaces adjacent to joint sealants.

C. Acoustical-Joint-Sealant Schedule: Include the following information:

1. Joint-sealant application, joint location, and designation.
2. Joint-sealant manufacturer and product name.
3. Joint-sealant formulation.
4. Joint-sealant color.

1.3 INFORMATIONAL SUBMITTALS

A. Test and Evaluation Reports: For each kind of acoustical joint sealant, for tests performed by a qualified testing agency or by manufacturer and witnessed by a qualified testing agency.

B. Sample Warranties: For special warranties.

1.4 CLOSEOUT SUBMITTALS

A. Warranty Documentation:

1. Manufacturers' special warranties.
2. Installer's special warranties.

**NISQUALLY STATE PARK
NEW FULL SERVICE PARK – PHASE 2**

1.5 WARRANTY

- A. Installer's Special Warranty: Installer agrees to repair or replace acoustical joint sealants that do not comply with performance and other requirements specified in this Section within specified warranty period.
 - 1. Warranty Period: 2 years from date of Substantial Completion.
- B. Manufacturer's Special Warranty: Manufacturer agrees to furnish acoustical joint sealants to repair or replace those joint sealants that do not comply with performance and other requirements specified in this Section within specified warranty period.
 - 1. Warranty Period: 5 years from date of Substantial Completion.

PART 2 - PRODUCTS

2.1 PERFORMANCE CRITERIA

- A. Provide acoustical joint-sealant products that effectively reduce airborne sound transmission through perimeter joints and openings in building construction, as demonstrated by testing representative assemblies according to ASTM E90.

2.2 ACOUSTICAL JOINT SEALANTS

- A. Comply with requirements in Section 079200 – Joint Sealants.
- B. Acoustical Sealant for Concealed and Exposed Joints (SLNT-AL2): Manufacturer's standard nonsag, paintable, nonstaining latex acoustical sealant complying with ASTM C834.
 - 1. Non-Fire Rated Products: Subject to compliance with requirements, provide one of the following:
 - a. Accumetric LLC: BOSS 826 Acoustical Sound Sealant.
 - b. Franklin International: Titebond Acoustical Smoke & Sound Sealant.
 - c. Hilti, Inc.: CP 506 Smoke and Acoustic Sealant.
 - d. Momentive Performance Materials: RCS20 Siliconized Acrylic Sealant.
 - e. Pecora Corporation: AIS-919.
 - f. Soudal Accumetric: Soudacryl C834.
 - g. USG Corporation: Sheetrock Acoustical Sealant.
 - 2. Fire Rated Products: Subject to compliance with requirements, provide one of the following:
 - a. Master Builders Solutions: MasterSeal NP 520.
 - b. Henkel Corporation: OSI Pro-Series SC175 Draft & Acoustical Sound Sealant.
 - c. Pecora Corporation: AC-20 FTR.
 - d. OSI Sealants; Henkel Corporation: OSI SC175 Draft & Acoustical Sound Sealant.
 - e. Specified Technologies Inc. (STI): SpecSeal Smoke 'N' Sound Sealant.

**NISQUALLY STATE PARK
NEW FULL SERVICE PARK – PHASE 2**

- f. Tremco Incorporated: Tremflex 834.
 - g. USG Corporation: Sheetrock Acoustical Sealant.
- 3. Colors of Exposed Acoustical Joint Sealants: As selected by Architect from manufacturer's full range of colors.
 - 4. Movement Capability: Plus/minus 12-1/2 percent.
 - 5. Surface-Burning Characteristics: Comply with ASTM E84.
 - a. Flame-Spread Index: 10 or less.
 - b. Smoke-Developed Index: 10 or less.

2.3 MISCELLANEOUS MATERIALS

- A. Primer: Material recommended by acoustical-joint-sealant manufacturer where required for adhesion of sealant to joint substrates.
- B. Cleaners for Nonporous Surfaces: Chemical cleaners acceptable to manufacturers of sealants and sealant backing materials, free of oily residues or other substances capable of staining or harming joint substrates and adjacent nonporous surfaces in any way, and formulated to promote optimum adhesion of sealants to joint substrates.
- C. Masking Tape: Nonstaining, nonabsorbent material compatible with joint sealants and surfaces adjacent to joints.

PART 3 - EXECUTION

3.1 EXAMINATION

- A. Examine joints indicated to receive acoustical joint sealants, with Installer present, for compliance with requirements for joint configuration, installation tolerances, and other conditions affecting performance of the Work.
- B. Proceed with installation only after unsatisfactory conditions have been corrected.

3.2 PREPARATION

- A. Surface Cleaning of Joints: Clean out joints immediately before installing acoustical joint sealants to comply with joint-sealant manufacturer's written instructions.
- B. Joint Priming: Prime joint substrates where recommended by acoustical-joint-sealant manufacturer. Apply primer to comply with joint-sealant manufacturer's written instructions. Confine primers to areas of joint-sealant bond; do not allow spillage or migration onto adjoining surfaces.
- C. Masking Tape: Use masking tape where required to prevent contact of sealant or primer with adjoining surfaces that otherwise would be permanently stained or damaged by such contact or by cleaning methods required to remove sealant smears. Remove tape immediately after tooling without disturbing joint seal.

**NISQUALLY STATE PARK
NEW FULL SERVICE PARK – PHASE 2**

3.3 INSTALLATION OF ACOUSTICAL JOINT SEALANTS

- A. Comply with acoustical joint-sealant manufacturer's written installation instructions unless more stringent requirements apply.
- B. STC-Rated Assemblies: Seal construction at perimeters, behind control joints, and at openings and penetrations with a continuous bead of acoustical joint sealant. Install acoustical joint sealants at both faces of partitions, at perimeters, and through penetrations. Comply with ASTM C919, ASTM C1193, and manufacturer's written recommendations for closing off sound-flanking paths around or through assemblies, including sealing partitions to underside of floor slabs above acoustical ceilings.
 - 1. Apply acoustical sealant to close gaps between service outlets and penetrations, and gypsum board.
 - 2. Apply acoustical sealant to back of electrical J-boxes for power, telephone, and data prior to installation of gypsum board.
 - 3. Tightly fill gaps around penetrations (ducts, pipes, and conduit 1 inch or less with attenuation batt insulation.
 - 4. Fill gaps larger than 1 inch with putty pads or stick.
 - 5. Apply acoustical sealant at duct and piping penetrations.
- C. Acoustical Ceiling Areas: Apply acoustical joint sealant at perimeter edge moldings of acoustical ceiling areas in a continuous ribbon concealed on back of vertical legs of moldings before they are installed.

3.4 CLEANING

- A. Clean off excess sealant or sealant smears adjacent to joints as Work progresses by methods and with cleaning materials approved in writing by manufacturers of acoustical joint sealants and of products in which joints occur.

3.5 PROTECTION

- A. Protect acoustical joint sealants during and after curing period from contact with contaminating substances and from damage resulting from construction operations or other causes so sealants are without deterioration or damage at time of Substantial Completion. If, despite such protection, damage or deterioration occurs, cut out, remove, and repair damaged or deteriorated acoustical joint sealants immediately so installations with repaired areas are indistinguishable from original Work.

END OF SECTION

**NISQUALLY STATE PARK
NEW FULL SERVICE PARK – PHASE 2**

SECTION 081113 – HOLLOW METAL DOORS AND FRAMES

PART 1 - GENERAL

1.1 SUMMARY

A. Section Includes:

1. Interior standard steel doors and frames.
2. Exterior standard steel doors and frames.

1.2 ADMINISTRATIVE REQUIREMENTS

A. Coordination:

1. Coordinate installation of anchorages for hollow metal frames. Furnish setting drawings, templates, and directions for installing anchorages, including sleeves, concrete inserts, anchor bolts, and items with integral anchors. Deliver such items to Project site in time for installation.
2. Coordinate requirements for installation of door hardware, electrified door hardware, and access control and security systems.

B. Preinstallation Meeting: Conduct meeting at Project site.

1.3 ACTION SUBMITTALS

A. Product Data: For each type of product.

1. Include construction details, material descriptions, core descriptions, fire-resistance ratings, and finishes.

B. Shop Drawings: Include the following:

1. Elevations of each door and frame type.
2. Details of doors, including vertical- and horizontal-edge details and metal thicknesses.
3. Frame details for each frame type, including dimensioned profiles and metal thicknesses.
4. Locations of reinforcement and preparations for hardware.
5. Details of the following:
 - a. Each different wall opening condition.
 - b. Electrical raceway and preparation for electrified hardware, access control systems, and security systems.
 - c. Anchorages, joints, field splices, and connections.
 - d. Accessories.
 - e. Moldings, removable stops, and glazing.
 - f. Rough opening requirements.

**NISQUALLY STATE PARK
NEW FULL SERVICE PARK – PHASE 2**

- C. Product Schedule: For hollow-metal doors and frames, prepared by or under supervision of supplier, using same reference numbers for details and openings as those on Drawings. Coordinate with final Door Hardware Schedule.

1.4 INFORMATIONAL SUBMITTALS

- A. Qualification Data: For door inspector.
 - 1. Fire-Rated Door Inspector: Submit documentation of compliance with NFPA 80, Section 5.2.3.1.
 - 2. Egress Door Inspector: Submit documentation of compliance with NFPA 101, Section 7.2.1.15.4.
 - 3. Submit copy of DHI Fire and Egress Door Assembly Inspector (FDAI) certificate.
- B. Product Test Reports: For each type of fire-rated hollow-metal door and frame assembly and thermally rated door assemblies for tests performed by a qualified testing agency indicating compliance with performance requirements.

1.5 CLOSEOUT SUBMITTALS

- A. As-builts: For fire-rated doors, list of door numbers and applicable room name and number to which door accesses.

1.6 QUALITY ASSURANCE

- A. Fire-Rated Door Inspector Qualifications: Inspector for field quality control inspections of fire-rated door assemblies shall meet the qualifications set forth in NFPA 80, section 5.2.3.1 and the following:
 - 1. Door and Hardware Institute Fire and Egress Door Assembly Inspector (FDAI) certification.
- B. Egress Door Inspector Qualifications: Inspector for field quality control inspections of egress door assemblies shall meet the qualifications set forth in NFPA 101, Section 7.2.1.15.4 and the following:
 - 1. Door and Hardware Institute Fire and Egress Door Assembly Inspector (FDAI) certification.

1.7 DELIVERY, STORAGE, AND HANDLING

- A. Deliver hollow-metal doors and frames palletized, packaged, or crated to provide protection during transit and Project-site storage. Do not use nonvented plastic.
 - 1. Provide additional protection to prevent damage to factory-finished units.
- B. Deliver welded frames with 2 removable spreader bars across bottom of frames, tack welded to jambs and mullions.
- C. Store hollow-metal doors and frames vertically under cover at Project site with head up. Place on minimum 4 inch high wood blocking. Provide minimum 1/4 inch space between each stacked door to permit air circulation.

**NISQUALLY STATE PARK
NEW FULL SERVICE PARK – PHASE 2**

PART 2 - PRODUCTS

2.1 MANUFACTURERS

A. Standard Steel Doors and Frames:

1. Manufacturers: Subject to compliance with requirements, provide products by one of the following:
 - a. Baron Metal Industries, Inc. ; an Assa Abloy Group company.
 - b. Ceco Door Products; an Assa Abloy Group company.
 - c. Curries Company; an Assa Abloy Group company.
 - d. Pioneer Industries, Inc.
 - e. Steelcraft; an Allegion Brand.
 - f. Approved substitution.

B. Source Limitations:

1. Obtain hollow-metal Work from single source from single manufacturer.

2.2 PERFORMANCE CRITERIA

A. Fire-Rated Door Assemblies: Assemblies complying with NFPA 80 that are listed and labeled by a qualified testing agency acceptable to authorities having jurisdiction for fire-protection ratings indicated on Drawings, based on testing at positive pressure according to NFPA 252 or UL 10C.

1. Smoke- and Draft-Control Door Assemblies: Listed and labeled for smoke and draft control by a qualified testing agency acceptable to authorities having jurisdiction, based on testing according to UL 1784 and installed in compliance with NFPA 105.

B. Thermally Rated Door Assemblies: Provide door assemblies with R-Value of not less than 2.53 when tested according to ASTM C1363.

1. Door Thermal Resistance: R-Value of 0.39 or less.
2. Solid Doors: R-value of 2.71.

2.3 STANDARD STEEL DOORS AND FRAMES, GENERAL

A. Construct hollow-metal doors and frames to comply with standards indicated for materials, fabrication, hardware locations, hardware reinforcement, tolerances, clearances, and as specified.

B. Provide hollow-metal door and frame types at locations indicated in Door Schedule.

**NISQUALLY STATE PARK
NEW FULL SERVICE PARK – PHASE 2**

2.4 INTERIOR STANDARD STEEL DOORS AND FRAMES

A. Extra-Heavy-Duty Doors and Frames: SDI A250.8, Level 3; SDI A250.4, Level A.

1. Doors:

- a. Type: As indicated in the Door and Frame Schedule.
- b. Thickness: 1-3/4 inches.
- c. Face: Uncoated steel sheet, minimum 0.053 inch thick.
- d. Edge Construction: Model 2, Seamless.
- e. Edge Bevel: Provide manufacturer's standard beveled edges.
- f. Non-Fire-Rated Core: Vertical steel-stiffeners.
- g. Fire-Rated Core: Manufacturer's standard core for fire-rated doors.

2. Frames:

- a. Material: Uncoated steel sheet, minimum 0.067 inch thick.
- b. Construction: Face welded.

3. Exposed Finish: Prime.

B. Frames for Interior Wood Doors: SDI A250.8, Level 3; SDI A250.4, Level A.

1. Materials: Uncoated steel sheet, minimum 0.053 inch thick.
2. Construction: Face welded.
3. Exposed Finish: Prime.

2.5 EXTERIOR STANDARD STEEL DOORS AND FRAMES

A. Extra-Heavy-Duty Doors and Frames: SDI A250.8, Level 3; SDI A250.4, Level A.

1. Doors:

- a. Type: As indicated in the Door and Frame Schedule.
- b. Thickness: 1-3/4 inches.
- c. Face: Metallic-coated steel sheet, minimum 0.053 inch thick, with A60 coating.
- d. Edge Construction: Model 2, Seamless.
- e. Edge Bevel: Provide manufacturer's standard beveled edges.
- f. Top Edge Closures: Close top edges of doors with flush closures of same material as face sheets. Seal joints against water penetration.
- g. Bottom Edges: Close bottom edges of doors with end closures or channels of same material as face sheets.
- h. Non-Fire-Rated Core: Vertical steel-stiffeners and polyurethane insulation.
- i. Fire-Rated Core: Manufacturer's standard core for fire-rated doors.

2. Frames: Flush-mount-type with punch and dimple anchors bolt holes at anchor points.

- a. Material: Metallic-coated steel sheet, minimum 0.053 inch thick, with minimum A60 coating.
- b. Construction: Face welded.
- c. Exposed Finish: Prime.

**NISQUALLY STATE PARK
NEW FULL SERVICE PARK – PHASE 2**

2.6 FRAME ANCHORS

- A. Jamb Anchors: Anchors of minimum size and type required by applicable door and frame standard, and suitable for performance level indicated.
 - 1. Types:
 - a. Stud Wall Type: Not less than 0.042 inch thick steel sheet, designed to engage stud.
 - b. Compression Type for Drywall Slip-on (Knock-Down) Frames: Adjustable compression anchors.
 - 2. Quantity: Minimum of 3 anchors per jamb, with 1 additional anchor for frames with no floor anchor. Provide 1 additional anchor for each 24 inches of frame height above 7 feet.
 - 3. Postinstalled Expansion Anchor: Minimum 3/8 inch diameter bolts with expansion shields or inserts, with manufacturer's standard pipe spacer.
- B. Floor Anchors:
 - 1. Provide floor anchors for each jamb and mullion that extends to floor.
 - 2. Concrete Slabs with Underlayment: Adjustable-type anchors with extension clips, allowing not less than 2 inch height adjustment.
 - a. Terminate bottom of frames at top of underlayment.
- C. Material: ASTM A879, Commercial Steel (CS), 04Z coating designation; mill phosphatized.
 - 1. For anchors built into exterior walls, steel sheet complying with ASTM A1008 or ASTM A1011; hot-dip galvanized according to ASTM A153, Class B.

2.7 AUXILIARY ITEMS

- A. Tube-Steel Removable Mullions: Frame manufacturer's standard with malleable-iron top and bottom retainers, and prepared for strikes as follows unless indicated otherwise:
 - 1. Strikes: 2 standard recessed strikes.
- B. Fire-Exit Removable Mullions: Removable mullions for use with fire exit devices complying with NFPA 80 that are listed and labeled by a testing and inspecting agency acceptable to authorities having jurisdiction, for fire and panic protection, based on testing in accordance with UL 305 and NFPA 252. Use mullions only with exit devices for which they have been tested.

2.8 MATERIALS

- A. Recycled Content of Steel Products: Postconsumer recycled content plus 1/2 of preconsumer recycled content not less than 25 percent.
- B. Cold-Rolled Steel Sheet: ASTM A1008, Commercial Steel (CS), Type B; suitable for exposed applications.

**NISQUALLY STATE PARK
NEW FULL SERVICE PARK – PHASE 2**

- C. Hot-Rolled Steel Sheet: ASTM A1011, Commercial Steel (CS), Type B; free of scale, pitting, or surface defects; pickled and oiled.
- D. Metallic-Coated Steel Sheet: ASTM A653, Commercial Steel (CS), Type B.
- E. Inserts, Bolts, and Fasteners: Hot-dip galvanized according to ASTM A153.
- F. Power-Actuated Fasteners in Concrete: Fastener system of type suitable for application indicated, fabricated from corrosion-resistant materials, with clips or other accessory devices for attaching hollow-metal frames of type indicated.
- G. Foamed-in-Place Insulation: Manufacturer's standard, closed cell, spray-applied polyurethane type.
- H. Metal Patching Compound: Metal-filled, 2-component epoxy putty designed for use on various metal substrates.

2.9 FABRICATION

- A. Fabricate hollow-metal Work to be rigid and free of defects, warp, or buckle.
 - 1. Accurately form metal to required sizes and profiles, with minimum radius for metal thickness.
 - 2. Where practical, fit and assemble units in manufacturer's plant.
 - 3. To ensure proper assembly at Project site, clearly identify Work that cannot be permanently factory assembled before shipment.
- B. Provide doors and frames receiving electrified hardware with 1/2 inch flexible steel conduit, including sufficient number of conductor wires, to accommodate electric function specified; connectors, and cover box installed at each location electrified hardware is specified.
 - 1. Properly coordinate installation of mechanical hardware and hook-up of electrified function with company that is licensed by Washington Electricity Board to prevent voiding of manufacturer's warranty and labeling of opening.
- C. Hollow Metal Doors:
 - 1. Cores, Interior Doors: 0.042 inch thick vertical steel-stiffener welded in-place at 6 inches on center.
 - 2. Cores, Exterior and Insulated Doors: 0.042 inch thick vertical steel-stiffener welded in-place at 6 inches on center; filled with manufacturer's standard foamed-in-place polyurethane; faces chemically bonded to face sheets.
 - 3. Reinforcement: 1-piece steel channels continuously welded full length to face sheets.
 - a. Lock Channel: 0.067 inch thick steel, beveled 1/8 inch in 2 inch.
 - b. Hinge Channel: 0.093 inch thick steel, formed and tapered for hinges.
 - c. Top and Bottom Channels: 0.053 inch thick steel with flush channel filler cap to close top rail opening.
 - 1) Snap in caps are not accepted.
 - 2) Provide weep-hole openings in bottoms of exterior doors to permit moisture to escape.

**NISQUALLY STATE PARK
NEW FULL SERVICE PARK – PHASE 2**

- d. Closer Reinforcement Channel: 0.067 inch thick steel.
 - 4. Kraft paper honeycomb cores are not acceptable.
 - D. Hollow-Metal Frames: Fabricate in 1 piece except where handling and shipping limitations require multiple sections. Where frames are fabricated in sections, provide alignment plates or angles at each joint, fabricated of metal of same or greater thickness as frames.
 - 1. Provide frames with 1/8 inch integral kerf formed into frame soffit to accept weatherstripping for exterior openings and smoke gaskets for fire-rated openings.
 - a. Ship weatherstripping and smoke gaskets loose for installation after frames have been finished painted.
 - 2. Provide countersunk, flat-, or oval-head exposed screws and bolts for exposed fasteners unless otherwise indicated.
 - 3. Thermal Breaks Fabricate frames with minimum 1/16 inch positive thermal break and integral vinyl weatherstripping as required to meet specified door assembly U-values.
 - 4. Faces: 2 inches.
 - 5. Rabbets: Double 5/8 inch unless indicated otherwise.
 - 6. Backbends:
 - a. Wrap-Around Frames: Manufacturer's standard 1/2 inch nominal backbend.
 - b. Butted Frames: Custom 1-1/2 inch minimum backbends.
 - 7. Door Silencers: Except on weatherstripped frames, drill stops to receive door silencers as follows. Keep holes clear during construction.
 - a. Single-Door Frames: Drill stop in strike jamb to receive 3 door silencers.
 - b. Double-Door Frames: Drill stop in head jamb to receive 2 door silencers.
 - E. Hardware Preparation: Factory prepare hollow-metal doors and frames to receive templated mortised hardware, and electrical wiring; include cutouts, reinforcement, mortising, drilling, and tapping according to SDI A250.6, the Door Hardware Schedule, and templates.
 - 1. Reinforce doors and frames to receive nontemplated, mortised, and surface-mounted door hardware.
 - 2. Comply with BHMA A156.115 for preparing hollow-metal doors and frames for hardware.
- 2.10 STEEL FINISHES
- A. Prime Finish: Clean, pretreat, and apply manufacturer's standard primer.
 - 1. Shop Primer: Manufacturer's standard, fast-curing, lead- and chromate-free primer complying with SDI A250.10; recommended by primer manufacturer for substrate; compatible with substrate and field-applied coatings despite prolonged exposure.

**NISQUALLY STATE PARK
NEW FULL SERVICE PARK – PHASE 2**

B. Factory Finish: Clean, pretreat, and apply manufacturer's standard 2-coat, baked-on finish consisting of prime coat and electrostatic or thermoset topcoat, complying with ANSI/SDI A250.3.

1. Color and Gloss: As selected by Architect from manufacturer's full range.

2.11 LOUVERS

A. Provide louvers for interior doors, where indicated, which comply with SDI 111, with blades or baffles formed of 0.020 inch thick, cold-rolled steel sheet set into 0.032 inch thick steel frame.

1. Sightproof Louver: Stationary louvers constructed with inverted-V or inverted-Y blades.

B. Form corners of moldings with hairline joints. Provide fixed frame moldings on outside of exterior and on secure side of interior doors and frames.

PART 3 - EXECUTION

3.1 EXAMINATION

A. Examine door frames, with Installer present, before hanging doors.

1. Verify that installed frames comply with indicated requirements for type, size, location, and swing characteristics and have been installed with level heads and plumb jambs.

2. Reject doors with defects.

B. Proceed with installation only after unsatisfactory conditions have been corrected.

3.2 PREPARATION

A. Remove welded-in shipping spreaders installed at factory.

1. Restore exposed finish by grinding, filling, and dressing, as required to make repaired area smooth, flush, and invisible on exposed faces.

2. Touch up factory-applied finishes where spreaders are removed.

B. Drill and tap doors and frames to receive nontemplated, mortised, and surface-mounted door hardware.

3.3 INSTALLATION

A. Install hollow-metal doors and frames plumb, rigid, properly aligned, and securely fastened in place. Comply with approved Shop Drawings and with manufacturer's written instructions.

**NISQUALLY STATE PARK
NEW FULL SERVICE PARK – PHASE 2**

- B. Hollow-Metal Frames: Comply with ANSI/SDI A250.11.
1. Set frames accurately in position; plumbed, aligned, and braced securely until permanent anchors are set. After wall construction is complete, remove temporary braces without damage to completed Work.
 - a. Where frames are fabricated in sections, field splice at approved locations by welding face joint continuously; grind, fill, dress, and make splice smooth, flush, and invisible on exposed faces. Touch-up finishes.
 - b. Install frames with removable stops located on secure side of opening.
 2. Exterior Frames: After installation of anchor bolts is completed, fill dimpled anchor openings with metal patching compound. Cure and prep patching compound as recommended by patching compound manufacturer; ready for painting.
 3. Fire-Rated Openings: Install frames according to NFPA 80.
 4. Floor Anchors: Secure with postinstalled expansion anchors.
 - a. Floor anchors may be set with power-actuated fasteners instead of postinstalled expansion anchors if so indicated and approved on Shop Drawings.
 5. Fill inside of frames with spray-applied foam insulation.
 - a. Locations: Exterior frames and interior frames where indicated.
 6. In-Place Concrete or Masonry Construction: Secure frames in place with postinstalled expansion anchors. Countersink anchors, and fill and make smooth, flush, and invisible on exposed faces.
 7. Installation Tolerances: Adjust hollow-metal frames to the following tolerances:
 - a. Squareness: Plus or minus 1/16 inch, measured at door rabbet on a line 90 degrees from jamb perpendicular to frame head.
 - b. Alignment: Plus or minus 1/16 inch, measured at jambs on a horizontal line parallel to plane of wall.
 - c. Twist: Plus or minus 1/16 inch, measured at opposite face corners of jambs on parallel lines, and perpendicular to plane of wall.
 - d. Plumbness: Plus or minus 1/16 inch, measured at jambs at floor.
- C. Hollow-Metal Doors: Fit and adjust hollow-metal doors accurately in frames, within clearances specified below.
1. Non-Fire-Rated Steel Doors: Comply with SDI A250.8.
 2. Fire-Rated Doors: Install doors with clearances according to NFPA 80.
 3. Smoke-Control Doors: Install doors according to NFPA 105.

3.4 REPAIR

- A. Replace doors and frames that are damaged or that do not comply with requirements. Doors and frames may be repaired or refinished if Work complies with requirements and shows no evidence of repair or refinishing.

**NISQUALLY STATE PARK
NEW FULL SERVICE PARK – PHASE 2**

B. Touchups:

1. Prime-Coat: Immediately after erection, sand smooth rusted or damaged areas of prime coat and apply touchup of compatible air-drying, rust-inhibitive primer.
2. Metallic-Coated Surface: Clean abraded areas and repair with galvanizing repair paint according to manufacturer's written instructions.
3. Painting: Cleaning and touchup painting of abraded areas of paint are specified in Section 099600 – High Performance Coatings.

3.5 FIELD QUALITY CONTROL

A. Inspection Agency: Owner will engage a qualified inspector to perform inspections and to furnish reports to Architect.

B. Inspections:

1. Fire-Rated Door Inspections: Inspect each fire-rated door according to NFPA 80, Section 5.2.
2. Egress Door Inspections: Inspect each door equipped with panic hardware, each door equipped with fire exit hardware, each door located in an exit enclosure, each electrically controlled egress door, and each door equipped with special locking arrangements according to NFPA 101, section 7.2.1.15.

C. Repair or remove and replace installations where inspections indicate that they do not comply with specified requirements.

D. Reinspect repaired or replaced installations to determine if replaced or repaired door assembly installations comply with specified requirements.

E. Prepare and submit separate inspection report for each fire-rated door assembly indicating compliance with each item listed in NFPA 80 and NFPA 101.

3.6 ADJUSTING AND CLEANING

A. Operation: Rehang or replace doors that do not swing or operate freely.

B. Remove temporary coverings and protection of adjacent Work areas.

C. Clean installed products in accordance with manufacturer's instructions prior to Substantial Completion. Remove excess sealants, dirt, and other substances.

3.7 PROTECTION

A. Protect installed products from damage during remainder of construction activities.

END OF SECTION

**NISQUALLY STATE PARK
NEW FULL SERVICE PARK – PHASE 2**

SECTION 081416 – FLUSH WOOD DOORS

PART 1 - GENERAL

1.1 SUMMARY

A. Section Includes:

1. 5-ply flush wood veneer-faced doors for transparent finish.
2. Factory finishing flush wood doors.
3. Factory fitting flush wood doors to frames and factory machining for hardware.

1.2 ADMINISTRATIVE REQUIREMENTS

- A. Preinstallation Meetings: Conduct meeting at Project site.

1.3 ACTION SUBMITTALS

A. Product Data: For each type of product, including the following:

1. Door core materials and construction.
2. Door edge construction
3. Door face type and characteristics.
4. Door trim for openings.
5. Door frame construction.
6. Factory-machining criteria.
7. Factory-finishing specifications.

B. Shop Drawings: Indicate location, size, and hand of each door; elevation of each type of door; construction details not covered in Product Data; and the following:

1. Door schedule indicating door location, type, size, fire protection rating, and swing.
2. Door elevations, dimension and locations of hardware, lite cutouts, and glazing thicknesses.
3. Details of electrical raceway and preparation for electrified hardware, access control systems, and security systems.
4. Dimensions and locations of blocking for hardware attachment.
5. Dimensions and locations of mortises and holes for hardware.
6. Clearances and undercuts.
7. Requirements for veneer matching.
8. Doors to be factory finished and application requirements.
9. Apply WDMA Hallmark Certification Program label to Shop Drawings.

**NISQUALLY STATE PARK
NEW FULL SERVICE PARK – PHASE 2**

C. Samples for Verification:

1. Factory finishes applied to actual door face materials, approximately 6 by 6 inches, for each material and finish.
 - a. For each wood species and transparent finish, provide set of 3 Samples showing typical range of color and grain to be expected in finished Work.
2. Corner sections of doors, approximately 8 by 10 inches, with door faces and edges representing actual materials to be used.
3. Frames for light openings, 6 inches long, for each material, type, and finish required.

1.4 INFORMATIONAL SUBMITTALS

A. Qualification Data: For door inspector.

1. Fire-Rated Door Inspector: Submit documentation of compliance with NFPA 80, Section 5.2.3.1.
2. Egress Door Inspector: Submit documentation of compliance with NFPA 101, Section 7.2.1.15.4.
3. Submit copy of DHI's Fire and Egress Door Assembly Inspector (FDAI) certificate.

1.5 CLOSEOUT SUBMITTALS

A. Special warranties.

B. Quality Standard Compliance Certificates: WDMA Hallmark Certification Program certificates.

C. As-Builts: For fire-rated doors, list of door numbers and applicable room name and number to which door accesses.

1.6 QUALITY ASSURANCE

A. Manufacturer's Certification: Licensed participant in WDMA Hallmark Certification Program.

B. Fire-Rated Door Inspector Qualifications: Inspector for field quality-control inspections of fire-rated door assemblies shall comply with qualifications set forth in NFPA 80, Section 5.2.3.1 and the following:

1. DHI's Fire and Egress Door Assembly Inspector (FDAI) certification.

C. Egress Door Inspector Qualifications: Inspector for field quality-control inspections of egress door assemblies shall comply with qualifications set forth in NFPA 101, Section 7.2.1.15.4 and the following:

1. DHI's Fire and Egress Door Assembly Inspector (FDAI) certification.

**NISQUALLY STATE PARK
NEW FULL SERVICE PARK – PHASE 2**

1.7 DELIVERY, STORAGE, AND HANDLING

- A. Comply with requirements of referenced standard and manufacturer's written instructions.
- B. Package doors individually in cardboard cartons, and wrap bundles of doors in plastic sheeting.
 - 1. Stack wood doors as recommended by door manufacturer.
 - 2. Do not store in damp or wet areas; or in areas where sunlight might bleach veneer.
 - 3. Seal top and bottom edges with tinted sealer if stored more than 1 week.
 - 4. Break seal on site to permit ventilation/
- C. Mark each door on bottom rail with opening number used on Shop Drawings.

1.8 FIELD CONDITIONS

- A. Environmental Limitations: Do not deliver or install doors until spaces are enclosed and weathertight, wet-Work in spaces is complete and dry, and HVAC system is operating and maintaining temperature and relative humidity at levels designed for building occupants for remainder of construction period.

1.9 WARRANTY

- A. Special Warranty: Manufacturer agrees to repair or replace doors that fail in materials or workmanship within specified warranty period.
 - 1. Failures include the following:
 - a. Delamination of veneer.
 - b. Warping (bow, cup, or twist) more than 1/4 inch in a 42 by 84 inch section.
 - c. Telegraphing of core construction in face veneers exceeding 0.01 inch in a 3 inch span.
 - 2. Warranty shall also include installation and finishing that may be required due to repair or replacement of defective doors.
 - 3. Warranty Period for Solid-Core Interior Doors: Life of installation.

PART 2 - PRODUCTS

2.1 MANUFACTURERS

- A. Manufacturers: Subject to compliance with requirements, provide products by one of the following:
 - 1. Lynden Door, Inc.
 - 2. Marshfield-Algoma by Masonite Architectural.
 - 3. Mohawk by Masonite Architectural.
 - 4. Oregon Door.
 - 5. Vancouver Architectural Doors.
 - 6. VT Industries, Inc.
- B. Source Limitations: Obtain flush wood doors from single manufacturer.

**NISQUALLY STATE PARK
NEW FULL SERVICE PARK – PHASE 2**

2.2 PERFORMANCE CRITERIA

- A. Fire-Rated Wood Door Assemblies: Assemblies complying with NFPA 80 that are listed and labeled by a qualified testing agency acceptable to authorities having jurisdiction, for fire-protection ratings indicated on Drawings, based on testing at positive pressure in accordance with UL 10C or NFPA 252.

2.3 FLUSH WOOD DOORS, GENERAL

- A. Quality Standard: In addition to requirements specified, comply with ANSI/WDMA I.S. 1A.
 - 1. Contract Documents contain requirements that are more stringent than referenced quality standard. Comply with Contract Documents in addition to those of referenced quality standard.

2.4 SOLID-CORE, 5-PLY FLUSH WOOD VENEER-FACED DOORS FOR TRANSPARENT FINISH

- A. Interior Doors:
 - 1. Performance Grade: ANSI/WDMA I.S. 1A.
 - a. Heavy Duty.
 - 2. ANSI/WDMA I.S. 1A Grade: Custom.
 - 3. Faces: Single-ply wood veneer not less than 1/50 inch thick.
 - a. Species: Birch unless indicated otherwise.
 - b. Cut: Rotary cut or plain sliced (flat sliced).
 - c. Match Between Veneer Leaves: Book match.
 - d. Assembly of Veneer Leaves on Door Faces: Running match.
 - 4. Exposed Vertical and Top Edges: Applied wood edges of same species as faces and covering edges of crossbands – Architectural Woodwork Standards edge Type F.
 - a. Fire-Rated Single Doors: Provide edge construction with intumescent seals concealed by outer stile. Comply with specified requirements for exposed vertical edges.
 - b. Mineral-Core Doors: At hinge stiles, provide laminated-edge construction with improved screw-holding capability and split resistance. Comply with specified requirements for exposed edges.
 - 1) Screw-Holding Capability: As required for Performance Grades specified.
 - 5. Core for Non-Fire-Rated Doors:
 - a. Either wood stave or ANSI A208.1, Grade LD-2 particleboard.
 - 1) Screw Withdrawal, Door Face: 475 lbf.
 - 2) Screw Withdrawal, Vertical Door Edge: 475 lbf.

**NISQUALLY STATE PARK
NEW FULL SERVICE PARK – PHASE 2**

6. Core for Fire-Rated Doors: As required to achieve fire-protection rating indicated on Drawings.
 - a. Blocking for Mineral-Core Doors: Provide composite blocking with improved screw-holding capability approved for use in doors of fire-protection ratings indicated on Drawings as needed to eliminate through-bolting hardware.
7. Blocking: In accordance with WDMA T.M. 10, as required for Performance Grades specified.
8. Construction: 5 plies, hot-pressed bonded (vertical and horizontal edging is bonded to core), with entire unit abrasive planed before veneering.

2.5 LIGHT FRAMES

- A. Wood Beads for Light Openings in Wood Doors: Provide manufacturer's standard wood beads unless otherwise indicated.
 1. Wood Species:
 - a. Transparent Finishes: Same species as door faces.
 2. Profile: Manufacturer's standard shape unless indicated otherwise on Drawings.
 3. At wood-core doors with 20 minute fire-protection ratings, provide wood beads and metal glazing clips approved for such use.
- B. Wood-Veneered Beads for Light Openings in Fire-Rated Doors: At wood-core doors with greater than 20 minute fire-protection ratings, provide manufacturer's standard wood-veneered noncombustible beads matching veneer species of door faces and approved for use in doors of fire-protection rating indicated.
 1. Include concealed metal glazing clips where required for opening size and fire-protection rating indicated.

2.6 FABRICATION

- A. Factory fit doors to suit frame-opening sizes indicated.
 1. Comply with clearance requirements of referenced quality standard for fitting unless otherwise indicated.
 2. Comply with NFPA 80 requirements for fire-rated doors.
- B. Factory machine doors for hardware that is not surface applied.
 1. Locate hardware to comply with DHI-WDHS-3.
 2. Comply with final hardware schedules, door frame Shop Drawings, ANSI/BHMA-156.115-W, and hardware templates.
 3. Coordinate with hardware mortises in metal frames, to verify dimensions and alignment before factory machining.
 4. For doors scheduled to receive electrified locksets, provide factory-installed raceway and wiring to accommodate specified hardware.

**NISQUALLY STATE PARK
NEW FULL SERVICE PARK – PHASE 2**

- C. Openings: Factory cut and trim openings through doors.
 - 1. Light Openings: Trim openings with moldings of material and profile indicated.
 - 2. Glazing: Factory install glazing in doors indicated to be factory finished. Comply with applicable requirements in Section 088000 – Glazing.
 - 3. Seal edges of doors, edges of cutouts, and mortises after fitting and machining.

2.7 FACTORY FINISHING

- A. Comply with referenced quality standard for factory finishing.
 - 1. Complete fabrication before finishing.
 - 2. Finish faces, all 4 edges, edges of cutouts, and mortises.
 - 3. Stains and fillers may be omitted on bottom edges, edges of cutouts, and mortises.
- B. Transparent Finish:
 - 1. ANSI/WDMA I.S. 1A Grade: Custom.
 - 2. Finish: Architectural Woodwork Standards System-11, Polyurethane, Catalyzed.
 - 3. Sheen: Satin.

PART 3 - EXECUTION

3.1 EXAMINATION

- A. Examine doors and installed door frames, with Installer present, before hanging doors.
 - 1. Verify that installed frames comply with indicated requirements for type, size, location, and swing characteristics and have been installed with level heads and plumb jambs.
 - 2. Reject doors with defects.
- B. Proceed with installation only after unsatisfactory conditions have been corrected.

3.2 INSTALLATION

- A. Hardware: For installation, see Section 087100 – Door Hardware.
- B. Install doors to comply with manufacturer's written instructions and referenced quality standard, and as indicated.
- C. Install frames level, plumb, true, and straight.
 - 1. Shim as required with concealed shims. Install level and plumb to a tolerance of 1/8 inch in 96 inches.

**NISQUALLY STATE PARK
NEW FULL SERVICE PARK – PHASE 2**

2. Anchor frames to anchors or blocking built in or directly attached to substrates.
 - a. Secure with countersunk, concealed fasteners and blind nailing.
 - b. Use fine finishing nails or finishing screws for exposed fastening, countersunk and filled flush with woodwork.
 - 1) For factory-finished items, use filler matching finish of items being installed.
3. Install fire-rated doors and frames in accordance with NFPA 80.

D. Job-Fitted Doors:

1. Align and fit doors in frames with uniform clearances and bevels as indicated below.
 - a. Do not trim stiles and rails in excess of limits set by manufacturer or permitted for fire-rated doors.
2. Machine doors for hardware.
3. Seal edges of doors, edges of cutouts, and mortises after fitting and machining.
4. Clearances:
 - a. Provide 1/8 inch at heads, jambs, and between pairs of doors.
 - b. Provide 1/8 inch from bottom of door to top of decorative floor finish or covering unless otherwise indicated on Drawings.
 - c. Where threshold is shown or scheduled, provide 1/4 inch from bottom of door to top of threshold unless otherwise indicated.
 - d. Comply with NFPA 80 for fire-rated doors.
5. Bevel non-fire-rated doors 1/8 inch in 2 inches at lock and hinge edges.
6. Bevel fire-rated doors 1/8 inch in 2 inches at lock edge; trim stiles and rails only to extent permitted by labeling agency.

E. Factory-Fitted Doors: Align in frames for uniform clearance at each edge.

F. Factory-Finished Doors: Restore finish before installation if fitting or machining is required at Project site.

3.3 REPAIR

A. Replace doors and frames that are damaged or that do not comply with requirements. Doors and frames may be repaired or refinished if Work complies with requirements and shows no evidence of repair or refinishing.

B. Touchups:

1. **Primer:** Immediately after erection, sand smooth damaged areas of prime coat and apply touchup of compatible air-drying primer.
2. **Painting:** Cleaning and touchup painting of abraded areas of paint are specified in painting Sections.

**NISQUALLY STATE PARK
NEW FULL SERVICE PARK – PHASE 2**

3.4 FIELD QUALITY CONTROL

- A. Inspection Agency: Owner will engage a qualified inspector to perform inspections and to furnish reports to Architect.
- B. Inspections:
 - 1. Provide inspection of installed Work through WDMA Hallmark Certification Program, certifying that wood doors and frames, including installation, comply with requirements of WDMA standards for specified grades.
 - 2. Fire-Rated Door Inspections: Inspect each fire-rated door in accordance with NFPA 80, Section 5.2.
 - 3. Egress Door Inspections: Inspect each door equipped with panic hardware, each door equipped with fire exit hardware, each door located in an exit enclosure, each electrically controlled egress door, and each door equipped with special locking arrangements in accordance with NFPA 101, Section 7.2.1.15.
- C. Repair or remove and replace installations where inspections indicate that they do not comply with specified requirements.
- D. Reinspect repaired or replaced installations to determine if replaced or repaired door assembly installations comply with specified requirements.
- E. Prepare and submit separate inspection report for each fire-rated door assembly indicating compliance with each item listed in NFPA 80 and NFPA 101.

3.5 ADJUSTING

- A. Operation: Rehang or replace doors that do not swing or operate freely.

3.6 CLEANING

- A. Remove temporary coverings and protection of adjacent Work areas.
- B. Clean installed products in accordance with manufacturer's instructions prior to Substantial Completion. Remove excess sealants, glazing materials, dirt, and other substances.

3.7 PROTECTION

- A. Protect installed products from damage during remainder of construction activities until Substantial Completion.

END OF SECTION

**NISQUALLY STATE PARK
NEW FULL SERVICE PARK – PHASE 2**

SECTION 083613 – SECTIONAL DOORS

PART 1 - GENERAL

1.1 SUMMARY

A. Section Includes:

1. Electrically operated sectional doors.

1.2 ACTION SUBMITTALS

A. Product Data: For each type and size of sectional door and accessory.

1. Include construction details, material descriptions, dimensions of individual components, profile door sections, and finishes.
2. For power-operated doors, include rated capacities, operating characteristics, electrical characteristics, and furnished accessories.

B. Shop Drawings: For each installation and for special components not dimensioned or detailed in manufacturer's Product Data. Include the following:

1. Plans, elevations, sections, and mounting details.
2. Details of equipment assemblies. Indicate dimensions, required clearances, method of field assembly, components, and location and size of each field connection.
3. Points of attachment and their corresponding static and dynamic loads imposed on structure.
4. Diagrams for power, signal, and control wiring.

C. Samples for Verification: For each type of exposed finish and for each color and texture required on the following components, in manufacturer's standard sizes:

1. Metal for door sections.
2. Hardware.

1.3 INFORMATIONAL SUBMITTALS

A. Qualification Data: For Installer.

B. Seismic Qualification Certificates: For sectional doors, accessories, and components, from manufacturer.

1.4 CLOSEOUT SUBMITTALS

A. Maintenance Data: For sectional doors to include in maintenance manuals.

**NISQUALLY STATE PARK
NEW FULL SERVICE PARK – PHASE 2**

1.5 QUALITY ASSURANCE

- A. Installer Qualifications: An entity with a minimum of 5 years of experience installing products specified in this Section that employs installers and supervisors who are trained and approved by manufacturer for both installation and maintenance of units required for this Project.
- B. Regulatory Requirements:
 - 1. Comply with applicable provisions in U.S. Architectural & Transportation Barriers Compliance Board's "Americans with Disabilities Act (ADA), Accessibility Guidelines (ADAAG)" and ICC A117.1.

1.6 WARRANTY

- A. Special Warranty: Manufacturer agrees to repair or replace components of sectional doors that fail in materials or workmanship within specified warranty period.
 - 1. Failures include the following:
 - a. Structural failures including excessive deflection.
 - b. Failure of components or operators before reaching required number of operation cycles.
 - c. Faulty operation of hardware.
 - d. Deterioration of metals, metal finishes, and other materials beyond normal weathering and use; rust through.
 - a. Delamination of exterior or interior facing materials.
 - 2. Warranty Periods: From date of Substantial Completion:
 - a. Delamination and Rust-Through: 10 years.
 - b. Other Components: 1 year.
 - c. Electric Door Operator: 2 years.
- B. Special Finish Warranty: Manufacturer agrees to repair or replace components that show evidence of deterioration of factory-applied finishes within specified warranty period.
 - 1. Warranty Period: 10 years from date of Substantial Completion.

PART 2 - PRODUCTS

2.1 MANUFACTURERS, GENERAL

- A. Source Limitations: Obtain sectional doors from single source from single manufacturer.
 - 1. Obtain operators and controls from sectional door manufacturer.

**NISQUALLY STATE PARK
NEW FULL SERVICE PARK – PHASE 2**

2.2 PERFORMANCE CRITERIA

- A. General Performance: Provide sectional doors that comply with performance criteria specified without failure due to defective manufacture, fabrication, installation, or other defects in construction.
- B. Structural Performance, Exterior Doors: Capable of withstanding the design wind loads.
 - 1. Design Wind Load: Uniform pressure (velocity pressure) of 20 lbf/sq. ft., acting inward and outward unless indicated otherwise.
 - 2. Testing: According to ASTM E330 or DASMA 108 for garage doors and complying with the acceptance criteria of DASMA 108.
 - 3. Deflection Limits: Design sectional doors to withstand design wind loads without evidencing permanent deformation or disengagement of door components.
 - a. Deflection of door sections in horizontal position (open) shall not exceed 1/120 of door width.
 - b. Deflection of horizontal track assembly shall not exceed 1/240 of door height.
- C. Seismic Performance: Sectional doors shall withstand effects of earthquake motions determined according to ASCE 7.
 - 1. Component Importance Factor: 1.0.

2.3 SECTIONAL-DOOR ASSEMBLIES, GENERAL

- A. Fabricate sectional doors so that finished door assembly is rigid and aligned with tight hairline joints; free of warp, twist, and deformation; and complies with requirements in DASMA 102.
- B. Fabricate sectional doors from single sheets, not more than 24 inches high; with horizontal meeting edges rolled to continuous, interlocking, keyed, rabbeted, shiplap, or tongue-in-groove, with weather- and pinch-resistant seals, and reinforcing flange return.

2.4 INSULATED SECTIONAL DOOR ASSEMBLIES

- A. Heavy Duty Steel Sectional Door (SOD-1): Insulated.
 - 1. Products: Subject to compliance with requirements, provide one of the following:
 - a. C.H.I. Overhead Doors: Model 3285.
 - b. Clopay Building Products Company: Model 3200.
 - c. ENTREMATIC: Kelley KE2432.
 - d. Overhead Door Corp.: 470 Series Insulated Steel Door.
 - e. Raynor: ThermaSeal TM200C.
 - 2. Operation Cycles: Door components and operators capable of operating for not less than 50,000 operation cycles. One operation cycle is complete when door is opened from closed position to the open position and returned to closed position.

**NISQUALLY STATE PARK
NEW FULL SERVICE PARK – PHASE 2**

3. Air Infiltration: DASMA 105 or ASTM E283; maximum rate of 0.12 cfm/sq. ft. at 15 mph.
4. R-Value: Minimum 9.0.
5. U-Value: Minimum 0.110.
6. Steel Door Sections: ASTM A653, zinc-coated (galvanized), cold-rolled, commercial steel sheet minimum G60 zinc coating.
 - a. Door-Section Thickness: 2 inches.
 - 1) Thermal-Break Construction: Provide sections with continuous thermal-break construction separating the exterior and interior faces of door.
 - b. Section Faces:
 - 1) Exterior Face: Fabricated from single sheets, not more than 24 inches high; with horizontal meeting edges rolled to continuous, interlocking, keyed, rabbeted, shiplap, or tongue-in-groove, weather- and pinch-resistant seals and reinforcing flange return.
 - a) Steel Sheet: With minimum nominal coated thickness of 0.022 inch.
 - b) Surface: Manufacturer's standard, ribbed.
 - 2) Interior Face: Enclose insulation completely within steel exterior facing and interior facing material, with no exposed insulation. Provide the following interior-facing material:
 - a) Steel Sheet: With minimum nominal coated thickness of 0.017 inch.
 - c. End Stiles: Enclose open ends of sections with channel end stiles formed from galvanized-steel sheet not less than 0.064 inch nominal coated thickness and welded to door section.
 - d. Intermediate Stiles: Provide intermediate stiles formed from not less than 0.064 inch thick galvanized-steel sheet, cut to door section profile, and welded in place. Space stiles not more than 48 inches apart.
 - e. Section Reinforcing: Horizontal and diagonal reinforcement as required to stiffen door and for wind loading. Provide galvanized-steel bars, struts, trusses, or strip steel, formed to depth and bolted or welded in place. Ensure that reinforcement does not obstruct vision lites.
 - 1) Bottom Section: Reinforce section with a continuous channel or angle conforming to bottom-section profile and allowing installation of astragal (weatherseal).
 - 2) Hardware Locations: Provide reinforcement for hardware attachment.
 - f. Thermal Insulation: Insulate interior of steel sections with door manufacturer's standard CFC-free insulation of type indicated below:
 - 1) Foamed-in-Place Insulation: Polyurethane, foamed in place to completely fill interior of section and pressure bonded to face sheets to prevent delamination under wind load.

**NISQUALLY STATE PARK
NEW FULL SERVICE PARK – PHASE 2**

- 2) Fire-Resistance Characteristics: Maximum flame-spread and smoke-developed indexes of 75 and 450, respectively, in accordance with ASTM E84.

2.5 TRACKS AND ACCESSORIES

- A. Track: Manufacturer's standard, galvanized-steel high-lift track system. Provide complete system including brackets, bracing, and reinforcement to ensure rigid support of ball-bearing roller guides for specified door type, size, weight, and loading.
 1. Material: Galvanized steel, ASTM A653, minimum G60 zinc coating.
 2. Size: 2 inch or 3 inch as recommended in writing by manufacturer for door size, weight, track configuration and door clearances indicated on Drawings.
 3. Track Reinforcement and Supports: Galvanized-steel members to support track without sag, sway, and vibration during opening and closing of doors. Slot vertical sections of track spaced 2 inches apart for door-drop safety device.
 - a. Vertical Track: Incline vertical track to ensure weathertight closure at jambs. Provide continuous reinforcing angle attached to track and wall.
 - b. Horizontal Track: Provide continuous reinforcing angle from curve in track to end of track, attached to track and supported at points by laterally braced attachments to overhead structural members.
- B. Weatherseals: Replaceable, adjustable, continuous, compressible weatherstripping gaskets of flexible rubber or neoprene fitted to bottom, top, and jambs of door. Provide combination bottom weatherseal and sensor edge for bottom seal.

2.6 HARDWARE

- A. Heavy-duty, corrosion-resistant hardware, with hot-dip galvanized, stainless-steel, or other corrosion-resistant fasteners, to suit door type.
 1. Hinges: Heavy-duty, galvanized-steel hinges of not less than 0.079 inch nominal coated thickness at each end stile and at each intermediate stile, according to manufacturer's written recommendations for door size.
 - a. Attach hinges to door sections through stiles and rails with bolts and lock nuts or lock washers and nuts. Use rivets or self-tapping fasteners where access to nuts is impossible.
 - b. Provide double-end hinges where required, for doors more than 16 feet wide unless otherwise recommended by door manufacturer.
 2. Rollers: Heavy-duty rollers with steel ball-bearings in case-hardened steel races, mounted with varying projections to suit slope of track. Extend roller shaft through both hinges where double hinges are required. Match roller-tire diameter to track width.
 - a. Roller-Tire Material: Case-hardened steel.
 3. Push/Pull Handles: Equip each door with galvanized-steel lifting handles on each side of door, finished to match door.

**NISQUALLY STATE PARK
NEW FULL SERVICE PARK – PHASE 2**

B. Locking Device:

1. Slide Bolt: Fabricate with side-locking bolts to engage through slots in tracks for locking by padlock, located on single-jamb side, operable from inside only.
2. Locking Device Assembly: Fabricate with cylinder lock, spring-loaded deadbolt, operating handle, cam plate, and adjustable locking bars to engage through slots in tracks.
 - a. Lock Cylinders: Cylinders specified in Section 087100 – Door Hardware.
 - b. Keying: Keyed to building keying system.
 - c. Keys: 3 for each cylinder.
3. Chain Lock Keeper: Suitable for padlock.
4. Safety Interlock Switch: Equip power-operated doors with safety interlock switch to disengage power supply when door is locked.

2.7 COUNTERBALANCE MECHANISM

- A. Torsion Spring: Adjustable-tension torsion springs complying with requirements of DASMA 102 for number of operation cycles indicated, mounted on torsion shaft.
- B. Cable Drums and Shaft for Doors: Cast-aluminum cable drums mounted on torsion shaft and grooved to receive door-lifting cables as door is raised.
 1. Mount counterbalance mechanism with manufacturer's standard ball-bearing brackets at each end of torsion shaft.
 2. Provide one additional midpoint bracket for shafts up to 16 ft. long and 2 additional brackets at 1/3 points to support shafts more than 16 ft. long unless closer spacing is recommended in writing by door manufacturer.
 3. Cables: Galvanized-steel, multistrand, lifting cables with cable safety factor of at least 5 to 1.
 4. Cable Safety Device: Include a spring-loaded steel or bronze cam mounted to bottom door roller assembly on each side and designed to automatically stop door if lifting cable breaks.
 5. Bracket: Provide anchor support bracket as required to connect stationary end of spring to wall and to level shaft and prevent sag.
 6. Bumper: Provide spring bumper at each horizontal track to cushion door at end of opening operation.

2.8 ELECTRIC DOOR OPERATORS

- A. Electric door operator assembly of size and capacity recommended and provided by door manufacturer for door and "operation cycles" requirement specified, with electric motor and factory-prewired motor controls, starter, gear-reduction unit, solenoid-operated brake, clutch, control stations, control devices, integral gearing for locking door, and accessories required for proper operation.
 1. Product: As recommended by sectional door manufacturer for size and type of door and for lift conditions.
 2. Model HCTDCUL was recommended by A3 Acoustics for its sound isolators. June 2020
 3. Comply with NFPA 70.

**NISQUALLY STATE PARK
NEW FULL SERVICE PARK – PHASE 2**

4. Control equipment complying with NEMA ICS 1, NEMA ICS 2, and NEMA ICS 6; with NFPA 70, Class 2 control circuit, maximum 24-V ac or dc.
5. Safety: Listed in accordance with UL 325 by a qualified testing agency for commercial or industrial use; moving parts of operator enclosed or guarded if exposed and mounted at 8 ft. or lower.
6. Usage Classification: Heavy duty, 25 or more cycles per hour and more than 90 cycles per day.
7. Operator Type: Trolley or Jackshaft as required for track configurations.
 - a. Jackshaft-Type Operators: Provide at lift clearance and vertical-lift tracks.
 - b. Trolley-Type Operators: Provide low headroom and standard lift type tracks.
8. Motors: Reversible-type motor with controller (disconnect switch) for motor exposure indicated.
 - a. Electrical Characteristics:
 - 1) Phase: Single phase.
 - 2) Volts: 120 V.
 - 3) Hertz: 60.
 - 4) Horsepower: 1/2.
 - b. Control Wiring: Solid state circuitry with provisions for connection of safety edge to reverse, external radio control hook-up and maximum run timer. Provisions for timers to close, monitored reversing devices, mid stop and lock bar sensor capability.
9. Motor Size: Minimum size as indicated. If not indicated, large enough to start, accelerate, and operate door in either direction from any position, at a speed not less than 8 in./sec. and not more than 12 in./sec., without exceeding nameplate ratings or service factor.
10. Limit Switches: Equip motorized door with adjustable switches interlocked with motor controls and set to automatically stop door at fully opened and fully closed positions.
11. Obstruction Detection: Automatic external entrapment protection consisting of automatic safety sensor capable of protecting full width of door opening. Activation of device immediately stops and reverses downward door travel.
 - a. Monitored Entrapment Protection: Photoelectric sensor or electric sensor edge on bottom section designed to interface with door-operator control circuit to detect damage to or disconnection of sensor and complying with requirements in UL 325.
12. Control Station: Surface mounted, 3-position (open, close, and stop) control.
 - a. Operation: Push button and key.
 - b. Interior-Mounted Unit: Full-guarded, surface-mounted, heavy-duty type, with general-purpose NEMA ICS 6, Type 1.
 - c. Exterior-Mounted Unit: Full-guarded, surface-mounted, standard-duty, weatherproof type, NEMA ICS 6, Type 4, key operated.
13. Emergency Manual Operation: Chain type designed so required force for door operation does not exceed 25 lbf.

**NISQUALLY STATE PARK
NEW FULL SERVICE PARK – PHASE 2**

14. Emergency Operation Disconnect Device: Hand-operated disconnect mechanism for automatically engaging manual operator and releasing brake for emergency manual operation while disconnecting motor without affecting timing of limit switch. Mount mechanism so it is accessible from floor level. Include interlock device to automatically prevent motor from operating when emergency operator is engaged.
15. Motor Removal: Design operator so motor may be removed without disturbing limit-switch adjustment and without affecting emergency manual operation.

2.9 METAL FINISHES

- A. Comply with NAAMM/NOMMA's "Metal Finishes Manual for Architectural and Metal Products (AMP 500-06)" for recommendations for applying and designating finishes.
- B. Steel and Galvanized-Steel Finishes:
 1. Baked-Enamel or Powder-Coat Finish: Manufacturer's standard baked-on finish consisting of prime coat and thermosetting topcoat. Comply with coating manufacturer's written instructions for cleaning, pretreatment, application, and the following minimum dry film thickness:
 - a. Prime Coat: Minimum 0.2 mils.
 - b. Top Coat: Minimum 0.8 mils.
 - c. Color: White.

PART 3 - EXECUTION

3.1 EXAMINATION

- A. Examine substrates, areas, and conditions, with Installer present, for compliance with requirements for substrate construction and other conditions affecting performance of Work.
- B. Examine locations of electrical connections.
- C. Proceed with installation only after unsatisfactory conditions have been corrected.

3.2 INSTALLATION

- A. Install sectional doors and operating equipment complete with necessary hardware, anchors, inserts, hangers, and equipment supports, according to manufacturer's written instructions and as specified.
- B. Tracks: Fasten vertical track assembly to opening jambs and framing, spaced not more than 24 inches apart.
 1. Hang horizontal track assembly from structural overhead framing with angles or channel hangers attached to framing by welding or bolting, or both. Provide sway bracing, diagonal bracing, and reinforcement as required for rigid installation of track and door-operating equipment.

**NISQUALLY STATE PARK
NEW FULL SERVICE PARK – PHASE 2**

- C. Accessibility: Install sectional doors, switches, and controls along accessible routes in compliance with regulatory requirements for accessibility.
- D. Power-Operated Doors: Install automatic garage doors openers according to UL 325.

3.3 STARTUP SERVICES

- A. Engage a factory-authorized service representative to perform startup service.
 - 1. Complete installation and startup checks according to manufacturer's written instructions.
 - 2. Test and adjust controls and safety devices. Replace damaged and malfunctioning controls and equipment.

3.4 ADJUSTING

- A. Adjust hardware and moving parts to function smoothly so that doors operate easily, free of warp, twist, or distortion.
- B. Lubricate bearings and sliding parts as recommended by manufacturer.
- C. Adjust doors and seals to provide weather-resistant fit around entire perimeter.
- D. Touch-up Painting: Immediately after welding galvanized materials, clean welds and abraded galvanized surfaces and repair galvanizing to comply with ASTM A780.

3.5 DEMONSTRATION

- A. Engage a factory-authorized service representative to train Owner's maintenance personnel to adjust, operate, and maintain sectional doors.

END OF SECTION

**NISQUALLY STATE PARK
NEW FULL SERVICE PARK – PHASE 2**

SECTION 084213 – ALUMINUM-FRAMED ENTRANCES

PART 1 - GENERAL

1.1 SUMMARY

A. Section Includes:

1. Aluminum-framed entrance door systems.

B. Related Requirements:

1. Section 084313 – Aluminum-Framed Storefronts.

1.2 ADMINISTRATIVE REQUIREMENTS

A. Preinstallation Meeting: Conduct meeting at Project site.

1. Convene meeting a minimum of 2 weeks prior to beginning Work of this Section.
2. Require attendance by parties directly affecting Work of this Section.
3. Review and discuss methods and procedures related to aluminum-framed entrances.

1.3 ACTION SUBMITTALS

A. Product Data: For each type of product.

1. Include construction details, material descriptions, dimensions of individual components and profiles, and finishes.

B. Shop Drawings: For aluminum-framed entrances. Include the following:

1. Plans, elevations, sections, full-size details, and attachments to other Work.
2. Glazing and fabrication methods.
3. Details of provisions for assembly expansion and contraction and for draining moisture occurring within assembly to exterior.
4. Full-size isometric details of each type of vertical-to-horizontal intersection of aluminum-framed entrances, showing the following:
 - a. Joinery, including concealed welds.
 - b. Anchorage.
 - c. Expansion provisions.
 - d. Glazing.
 - e. Flashing and drainage.
5. Show connection to and continuity with adjacent thermal, weather, air, and vapor barriers.

**NISQUALLY STATE PARK
NEW FULL SERVICE PARK – PHASE 2**

6. Include point-to-point wiring diagrams showing the following:
 - a. Power requirements for each electrically operated door hardware.
 - b. Location and types of switches, signal device, conduit sizes, number and size of wires.
7. Submit Shop Drawings that have been engineered and certified by professional engineer licensed in the State in which Project is located.
 - a. Include seal and signature of professional engineer on Shop Drawings.
- C. Samples for Verification: For each type of exposed finish required, in manufacturer's standard sizes.
- D. Fabrication Sample: Of each vertical-to-horizontal intersection of assemblies, made from 12 inch lengths of full-size components and showing details of the following:
 1. Joinery, including concealed welds.
 2. Anchorage.
 3. Expansion provisions.
 4. Glazing.
 5. Flashing and drainage.
- E. Entrance Door Hardware Schedule: Coordinate and comply with requirements specified in Section 087100 – Door Hardware.

1.4 INFORMATIONAL SUBMITTALS

- A. Energy Performance Certificates: For aluminum-framed entrances, accessories, and components, from manufacturer.
 1. Basis for Certification: NFRC-certified energy performance values for each aluminum-framed entrance.
- B. Test and Evaluation Reports:
 1. Product Test Reports: For aluminum-framed entrances, for tests performed by manufacturer and witnessed by a qualified testing agency.
- C. Qualification Statements: For Installer.

1.5 CLOSEOUT SUBMITTALS

- A. Operation and Maintenance Data: For aluminum-framed entrances.

1.6 QUALITY ASSURANCE

- A. Manufacturer Qualifications: Company that specializes in manufacturing aluminum-framed entrances comparable to systems specified for this Project with a minimum of 10 years of documented experience.

**NISQUALLY STATE PARK
NEW FULL SERVICE PARK – PHASE 2**

- B. Installer: An entity with a minimum of 10 years of documented experience installing aluminum-framed entrances comparable to systems specified of this Project that employs Installers and supervisors who are trained and approved by manufacturer.
 - 1. Qualified glazing contractor who is certified under North American Contractor Certification Program (NACC) for Architectural Glass & Metal (AG&M) contractors.
 - 2. Glazing technicians certified under Architectural Glass and Metal Technician (AGMT) certification program.
- C. Egress Door Inspector: Inspector for field quality-control inspections of egress door assemblies shall comply with qualifications set forth in NFPA 101, Section 7.2.1.15.4 and the following:
 - 1. DHI's Fire and Egress Door Assembly Inspector (FDAI) certification
- D. Product Options: Information on Drawings and in Specifications establishes requirements for aesthetic effects and performance characteristics of assemblies.
 - 1. Aesthetic effects are indicated by dimensions, arrangements, alignment, and profiles of components and assemblies as they relate to sightlines, to one another, and to adjoining construction.
 - 2. Do not change intended aesthetic effects, as judged solely by Architect, except with Architect's approval.
 - 3. If changes are proposed, submit comprehensive explanatory data to Architect for review.
- E. Mockups:
 - 1. Comply with mockup requirements in Section 084313 – Aluminum-Framed Storefronts.

1.7 WARRANTY

- A. Special Warranty: Manufacturer agrees to repair or replace components of aluminum-framed entrances that do not comply with requirements or that fail in materials or workmanship within specified warranty period.
 - 1. Failures include the following:
 - a. Structural failures including excessive deflection.
 - b. Noise or vibration created by wind and thermal and structural movements.
 - c. Deterioration of metals and other materials beyond normal weathering.
 - d. Failure of operating components.
 - 2. Warranty Period: 5 years from date of Substantial Completion.
- B. Special Finish Warranty, Anodized Finishes: Standard form in which manufacturer agrees to repair finishes or replace aluminum that shows evidence of deterioration of anodized finishes within specified warranty period.
 - 1. Warranty Period: 10 years from date of Substantial Completion

**NISQUALLY STATE PARK
NEW FULL SERVICE PARK – PHASE 2**

PART 2 - PRODUCTS

2.1 ALUMINUM-FRAMED ENTRANCE DOORS, THERMALLY-BROKEN

A. Entrance Doors, Wide Stile, Single Thermal Break:

1. Basis-of-Design Product: Subject to compliance with requirements, provide one of the following:
 - a. Arcadia, Inc.: WS512T Series.
 - b. EFCO Corporation: Series D502 Wide Stile ThermaStile.
 - c. Kawneer Company Inc.: 500T Insulpour Thermal Entrance.
 - d. Manko Window Systems, Inc.: 150i Wide Stile Isobar.
 - e. Oldcastle BuildingEnvelope: Model WS-500TC.
 - f. Tubelite, Inc.: Thermal-Block Wide Series.
 - g. U.S. Aluminum: Series 500TC – Wide Stile.
2. Door Thickness: 2-1/4 inch.
3. Door Design:
 - a. Stiles: 5 inch nominal width.
 - b. Top Rail: 5 inches.
 - c. Bottom Rail: 6-1/2 inches and 10 inches.
4. Framing Member Wall Thickness: 0.125 inch.
5. Glazing Thickness: 1 inch.
6. Door Finish: Superior-performance organic finish.

2.2 MANUFACTURERS

A. Source Limitations: Obtain components of aluminum-framed entrances and aluminum-framed storefront system, including framing and accessories, from single manufacturer

1. Provide electrified door hardware from same manufacturer as mechanical door hardware unless otherwise indicated.
 - a. Electrified modifications or enhancements made to a source manufacturer's product line by secondary or third party source will not be accepted.
2. Provide standard door hardware and electrified hardware as a single sourced package from same qualified supplier.

2.3 PERFORMANCE CRITERIA

- A. General Performance: Comply with performance requirements specified, as determined by testing of aluminum-framed entrances representing those indicated for this Project without failure due to defective manufacture, fabrication, installation, or other defects in construction.**

**NISQUALLY STATE PARK
NEW FULL SERVICE PARK – PHASE 2**

B. Structural Loads:

1. Wind and Other Design Loads: As indicated on Drawings.

C. Structural: Test in accordance with ASTM E330 as follows:

1. When tested at positive and negative wind-load design pressures, entrance doors do not evidence deflection exceeding specified limits.
2. When tested at 150 percent of positive and negative wind-load design pressures, entrance doors, including anchorage, do not evidence material failures, structural distress, or permanent deformation of main framing members exceeding 0.2 percent of span.
3. Test Durations: As required by design wind velocity, but not less than 10 seconds.

D. Energy Performance: Certified and labeled by manufacturer for energy performance as follows:

1. Thermal Transmittance (U-factor): U-factors for system not more than indicated as determined when tested in accordance with NFRC 100.
 - a. 0.52 Btu/sq. ft. x h x deg F.
2. Solar Heat-Gain Coefficient (SHGC): Determined when tested in accordance with NFRC 200.
 - a. SHGC of not more than 0.33.
3. Air Leakage: Determined when tested in accordance with AAMA/WDMA/CSA 101/I.S.2/A440.
 - a. Air leakage of not more than 1.0 cfm/sq. ft. at a static-air-pressure differential of 1.57 lbf/sq. ft. when tested according to ASTM E283.
4. Condensation-Resistance Factor (CRF): Determined when tested in accordance with AAMA 1503 or NFRC 500.
 - a. Minimum CRF for 49 (frame) and 68 (glass).

E. Thermal Movements: Allow for thermal movements resulting from ambient and surface temperature changes.

1. Temperature Change: 120 deg F, ambient; 180 deg F, material surfaces.

**NISQUALLY STATE PARK
NEW FULL SERVICE PARK – PHASE 2**

2.4 ALUMINUM-FRAMED ENTRANCE DOOR SYSTEMS

- A. Entrance Doors: Manufacturer's standard glazed entrance doors for manual-swing or automatic operation.
 - 1. Door Construction: Extruded-aluminum tubular rail and stile members. Mechanically fasten corners with reinforcing brackets that are deeply penetrated and fillet welded or that incorporate concealed tie rods.
 - a. Thermal Construction: High-performance plastic connectors separate aluminum members exposed to exterior from members exposed to interior.
 - 2. Door Design: As specified or as indicated on Drawings.
 - 3. Glazing Stops and Gaskets: Square, snap-on, extruded-aluminum stops and preformed gaskets.
 - a. Provide nonremovable glazing stops on outside of door.
 - 4. Door Finish: As specified or as indicated on Drawings.
- B. Framing Members: Manufacturer's standard extruded aluminum, minimum 0.125 inch thick and reinforced as required to support imposed loads.
 - 1. Nominal Size: As specified or as indicated on Drawings.
 - 2. Exterior Framing Construction: Thermally broken.
 - 3. Finish: Match door finish.
- C. Backer Plates: Manufacturer's standard, continuous backer plates for framing members, if not integral, where framing abuts adjacent construction.
- D. Brackets and Reinforcements: Manufacturer's standard high-strength aluminum with nonstaining, nonferrous shims for aligning system components.
- E. Thermal Break Material: 2-part chemically-curing, high-density polyurethane, mechanically and adhesively joined to aluminum framing sections
 - 1. Thermal Break Design: Comply with AAMA TIR-A8 and test in accordance with AAMA 505.
 - 2. Minimum Thermal Separation: 1/4 inch.
- F. Thermal Break Material: Continuous, extruded polyamide with minimum 25 percent glass-fiber reinforcing, mechanically crimped into cross-knurled cavities.
 - 1. Thermal Break Design: Comply with AAMA TIR-A8 and test in accordance with AAMA 505.
 - 2. Minimum Thermal Separation: 1/4 inch.

**NISQUALLY STATE PARK
NEW FULL SERVICE PARK – PHASE 2**

2.5 MATERIALS

- A. Aluminum: Alloy and temper recommended by manufacturer for type of use and finish indicated:
 - 1. Sheet and Plate: ASTM B209.
 - 2. Extruded Bars, Rods, Profiles, and Tubes: ASTM B221.
 - 3. Structural Profiles: ASTM B308.
- B. Steel Reinforcement:
 - 1. Structural Shapes, Plates, and Bars: ASTM A36.
 - 2. Cold-Rolled Sheet and Strip: ASTM A1008.
 - 3. Hot-Rolled Sheet and Strip: ASTM A1011.
 - 4. Primer: Manufacturer's standard zinc-rich, corrosion-resistant primer complying with SSPC-PS Guide No. 12.00; applied immediately after surface preparation and pretreatment. Select surface preparation methods according to recommendations in SSPC-SP COM, and prepare surfaces according to applicable SSPC standard.
- C. Thermal Break Material: Manufacturer's standard method consisting of one of the following:
 - 1. Polyurethane: Continuous, 2-part chemically-curing, high-density polyurethane, mechanically and adhesively joined to aluminum framing sections.
 - 2. Polyamide: Continuous, extruded polyamide with minimum 25 percent glass-fiber reinforcing, mechanically crimped into cross-knurled cavities
 - 3. Thermal Break Design: Comply with AAMA TIR-A8 and test in accordance with AAMA 505.
- D. Recycled Content of Aluminum Components: Postconsumer recycled content plus 1/2 half of preconsumer recycled content not less than 50 percent.
- E. Recycled Content of Steel Components: Postconsumer recycled content plus 1/2 half of preconsumer recycled content not less than 50 percent.

2.6 ENTRANCE DOOR HARDWARE

- A. Entrance Door Hardware: Refer to Section 087100 – Door Hardware for hardware not specified in this Section.

2.7 GLAZING

- A. Glazing: Comply with Section 088000 – Glazing.
- B. Glazing Gaskets: ASTM C509 or ASTM C864.
 - 1. Manufacturer's standard non-shrinking, weather-resistant, compression-type, replaceable ethylene propylene diene monomer (EPDM).
 - 2. Color: Black, unless indicated otherwise.
- C. Glazing Sealants: As recommended by manufacturer and complying with Section 088000 – Glazing.

**NISQUALLY STATE PARK
NEW FULL SERVICE PARK – PHASE 2**

2.8 ACCESSORIES

- A. Low-Voltage Door Operators: Section 087000 – Door Hardware.
- B. Fasteners and Accessories: Manufacturer's standard corrosion-resistant, nonstaining, nonbleeding fasteners and accessories compatible with adjacent materials.
 - 1. Use self-locking devices where fasteners are subject to loosening or turning out from thermal and structural movements, wind loads, or vibration.
 - 2. Reinforce members as required to receive fastener threads.
 - 3. Exposed Fasteners: Do not use exposed fasteners to greatest extent possible. Where exposed fasteners are unavoidable, provide exposed fasteners with countersunk Phillips screw heads, fabricated from 300 series stainless steel.
 - a. Where framing finish is other than clear anodized, finish exposed fasteners to match framing system.
- C. Anchors: 3-way adjustable anchors with minimum adjustment of 1 inch that accommodate fabrication and installation tolerances in material and finish compatible with adjoining materials and recommended by manufacturer.
 - 1. Concrete and Masonry Inserts: Hot-dip galvanized cast-iron, malleable-iron, or steel inserts complying with ASTM A123 or ASTM A153 requirements.
- D. Bituminous Paint: Cold-applied asphalt-mastic paint containing no asbestos, formulated for 30 mil thickness per coat.

2.9 FABRICATION

- A. Form or extrude aluminum shapes before finishing.
- B. Weld in concealed locations to greatest extent possible to minimize distortion or discoloration of finish. Remove weld spatter and welding oxides from exposed surfaces by descaling or grinding.
- C. Fabricate components that, when assembled, have the following characteristics:
 - 1. Profiles that are sharp, straight, and free of defects or deformations.
 - 2. Accurately fitted joints with ends coped or mitered.
 - 3. Physical and thermal isolation of glazing from framing members.
 - 4. Accommodations for thermal and mechanical movements of glazing and framing to maintain required glazing edge clearances.
 - 5. Fasteners, anchors, and connection devices that are concealed from view to greatest extent possible.
- D. Entrance Door Frames: Reinforce as required to support loads imposed by door operation and for installing entrance door hardware.
 - 1. Provide compression weatherstripping at fixed stops.
- E. Entrance Doors: Reinforce doors as required for installing entrance door hardware.

**NISQUALLY STATE PARK
NEW FULL SERVICE PARK – PHASE 2**

1. At exterior doors, provide weather sweeps applied to door bottoms.
- F. Entrance Door Hardware Installation: Factory install entrance door hardware to greatest extent possible. Cut, drill, and tap for factory-installed entrance door hardware before applying finishes.
- G. After fabrication, clearly mark components to identify their locations in Project in accordance with Shop Drawings.
- 2.10 ALUMINUM FINISHES
- A. Superior-Performance Organic Finish, 3-Coat PVDF: Fluoropolymer finish complying with AAMA 2605 and containing not less than 70 percent PVDF resin by weight in both color coat and clear topcoat.
1. Prepare, pretreat, and apply coating to exposed metal surfaces to comply with coating and resin manufacturers' written instructions.
 2. Color and Gloss: Match Permafluor Black.
- B. Concealed Steel Items: Prime with iron oxide paint.
- C. Liquid Strippable Coating: Apply in shop to prefinished surfaces to protect finish during fabrication, shipping, and field handling.

PART 3 - EXECUTION

- 3.1 EXAMINATION
- A. Examine areas, with Installer present, for compliance with requirements for installation tolerances and other conditions affecting performance of Work.
 - B. Ensure aluminum-framed storefronts and ready to receive Work of this Section.
 - C. Verify service for electronic door controls is available and of correct characteristics.
 - D. Proceed with installation only after unsatisfactory conditions have been corrected.
- 3.2 INSTALLATION, GENERAL
- A. Comply with manufacturer's written instructions.
 - B. Do not install damaged components.
 - C. Fit joints to produce hairline joints free of burrs and distortion.
 - D. Rigidly secure nonmovement joints.
 - E. Install anchors with separators and isolators to prevent metal corrosion and electrolytic deterioration and to prevent impeding movement of moving joints.

**NISQUALLY STATE PARK
NEW FULL SERVICE PARK – PHASE 2**

- F. Seal perimeter and other joints watertight unless otherwise indicated.
 - G. Metal Protection:
 - 1. Where aluminum is in contact with dissimilar metals, protect against galvanic action by painting contact surfaces with materials recommended by manufacturer for this purpose or installing nonconductive spacers.
 - 2. Where aluminum is in contact with concrete or masonry, protect against corrosion by painting contact surfaces with bituminous paint.
 - H. Set continuous sill members and flashing in full sealant bed, as specified in Section 079200 – Joint Sealants, to produce weathertight installation.
 - I. Install joint filler behind sealant as recommended by sealant manufacturer.
 - J. Install components plumb and true in alignment with established lines and grades.
- 3.3 INSTALLATION OF GLAZING
- A. Install glazing as specified in Section 088000 – Glazing.
- 3.4 INSTALLATION OF ALUMINUM-FRAMED ENTRANCE DOORS
- A. Install entrance doors to produce smooth operation and tight fit at contact points.
 - 1. Exterior Doors: Install to produce weathertight enclosure and tight fit at weatherstripping.
 - 2. Field-Installed Entrance Door Hardware: Install surface-mounted entrance door hardware in accordance with entrance door hardware manufacturers' written instructions using concealed fasteners to greatest extent possible.
 - B. Make final service connections to frames for electronic door controls.
- 3.5 ADJUSTING
- A. Adjust entrance doors and hardware for a tight fit at contact points and weatherstripping for smooth operation and weathertight closure.
- 3.6 CLEANING
- A. Clean exposed surfaces immediately after installing entrance doors.
 - 1. Avoid damaging protective coatings and finishes.
 - 2. Remove excess sealants, glazing materials, dirt, and other substances.
 - 3. Keep protective films and coverings in place until final cleaning.
 - B. Remove and replace glass that has been broken, chipped, cracked, abraded, or damaged during construction period.

**NISQUALLY STATE PARK
NEW FULL SERVICE PARK – PHASE 2**

3.7 PROTECTION

- A. Protect entrance framing and glass surfaces from contact with contaminating substances resulting from construction operations.
 - 1. If contaminating substances do contact entrance framing or glass surfaces, remove contaminants immediately according to manufacturer's written instructions.

3.8 MAINTENANCE SERVICE

- A. Entrance Door Hardware Maintenance:
 - 1. Maintenance Tools and Instructions: Furnish complete set of specialized tools and maintenance instructions as needed for Owner's continued adjustment, maintenance, and removal and replacement of entrance door hardware.
 - 2. Initial Maintenance Service: Beginning at Substantial Completion, provide 6 months' full maintenance by skilled employees of entrance door hardware Installer.
 - a. Include quarterly preventive maintenance, repair or replacement of worn or defective components, lubrication, cleaning, and adjusting as required for proper entrance door hardware operation at rated speed and capacity.
 - b. Use parts and supplies that are same as those used in manufacture and installation of original equipment.

END OF SECTION

**NISQUALLY STATE PARK
NEW FULL SERVICE PARK – PHASE 2**

SECTION 084313 – ALUMINUM-FRAMED STOREFRONTS

PART 1 - GENERAL

1.1 SUMMARY

A. Section Includes:

1. Aluminum-framed storefront systems.

B. Related Requirements:

1. Section 084213 – Aluminum-Framed Entrances.

1.2 ADMINISTRATIVE REQUIREMENTS

A. Preinstallation Meeting: Conduct meeting at Project site.

1. Convene meeting a minimum of 2 weeks prior to beginning Work of this Section.
2. Require attendance by parties directly affecting Work of this Section.
3. Review and discuss methods and procedures related to aluminum-framed storefronts, including the following:
 - a. Finalize construction schedule and verify availability of materials, Installer's personnel, equipment, and facilities needed to perform Work and avoid delays.
 - b. Coordination of finishes of aluminum storefront with other aluminum framing systems that match color and finish.
 - c. Coordinate interrelationship of aluminum storefront with other exterior wall components. Include provisions for structural anchorage, glazing, flashing, weeping, sealants, and protection of finishes.
 - d. Sequence of Work required to construct a watertight and weathertight exterior building envelope.
 - e. Inspect and discuss condition of substrate and other preparatory Work performed by other trades.

1.3 ACTION SUBMITTALS

A. Product Data: For each type of product.

1. Include construction details, material descriptions, dimensions of individual components and profiles, and finishes.

B. Shop Drawings: For aluminum-framed storefronts. Include the following:

1. Plans, elevations, sections, full-size details, and attachments to other Work.
2. Glazing and fabrication methods.

**NISQUALLY STATE PARK
NEW FULL SERVICE PARK – PHASE 2**

3. Details of provisions for assembly expansion and contraction and for draining moisture occurring within assembly to exterior.
 4. Full-size isometric details of each type of vertical-to-horizontal intersection of aluminum-framed storefronts, showing the following:
 - a. Joinery, including concealed welds.
 - b. Anchorage.
 - c. Expansion provisions.
 - d. Glazing.
 - e. Flashing and drainage.
 5. Show connection to and continuity with adjacent thermal, weather, air, and vapor barriers.
 6. Submit Shop Drawings that have been engineered and certified by professional engineer licensed in the State in which Project is located.
 - a. Include seal and signature of professional engineer on Shop Drawings.
- C. Samples for Verification: For each type of exposed finish required, in manufacturer's standard sizes.
- D. Fabrication Sample: Of each vertical-to-horizontal intersection of assemblies, made from 12 inch lengths of full-size components and showing details of the following:
1. Joinery, including concealed welds.
 2. Anchorage.
 3. Expansion provisions.
 4. Glazing.
 5. Flashing and drainage.
- 1.4 INFORMATIONAL SUBMITTALS
- A. Qualification Data: For Installer.
- B. Energy Performance Certificates: For aluminum-framed storefronts, accessories, and components, from manufacturer.
1. Basis for Certification: NFRC-certified energy performance values for each aluminum-framed storefront.
- C. Test and Evaluation Reports:
1. Product Test Reports: For aluminum-framed storefronts, for tests performed by manufacturer and witnessed by a qualified testing agency.
- D. Sample Warranties: For special warranties.
- 1.5 CLOSEOUT SUBMITTALS
- A. Maintenance Data: For aluminum-framed storefronts to include in maintenance manuals.

**NISQUALLY STATE PARK
NEW FULL SERVICE PARK – PHASE 2**

1.6 QUALITY ASSURANCE

- A. Company that specializes in manufacturing aluminum-framed storefronts comparable to systems specified for this Project with a minimum of 10 years of documented experience.
- B. Installer Qualifications: An entity with a minimum of 10 years of documented experience installing aluminum-framed storefronts comparable to systems specified of this Project that employs the following personnel:
 - 1. Installers and supervisors who are trained and approved by manufacturer
 - 2. Qualified glazing contractor who is certified under North American Contractor Certification Program (NACC) for Architectural Glass & Metal (AG&M) contractors.
 - 3. Glazing technicians certified under Architectural Glass and Metal Technician (AGMT) certification program.
- C. Product Options: Information on Drawings and in Specifications establishes requirements for aesthetic effects and performance characteristics of assemblies.
 - 1. Aesthetic effects are indicated by dimensions, arrangements, alignment, and profiles of components and assemblies as they relate to sightlines, to one another, and to adjoining construction.
 - 2. Do not change intended aesthetic effects, as judged solely by Architect, except with Architect's approval.
 - 3. If changes are proposed, submit comprehensive explanatory data to Architect for review.
- D. Mockups:
 - 1. Build mockups of typical wall area as shown on Drawings.
 - 2. Notify Architect and Owner's representative a minimum of 7 days in advance of dates and times when in-place mockups will be constructed.
 - 3. Set unit in opening, glaze framing system, install flashing and joint sealants.
 - a. Examine flashing of openings prior to installing joint sealant.
 - 4. Perform testing on mockups according to requirements in "Field Quality Control" Article.
 - 5. Approval of mockups does not constitute approval of deviations from Contract Documents contained in mockups unless Architect specifically approves such deviations in writing.
 - 6. Obtain Architect's approval of mockups before continuing installation of aluminum-framed storefronts.
 - 7. Subject to compliance with requirements, approved mockups may become part of completed Work if undisturbed at time of Substantial Completion.
 - 8. Maintain mockups during construction in an undisturbed condition as a standard for judging completed Work.

1.7 WARRANTY

- A. Special Warranty: Manufacturer agrees to repair or replace components of aluminum-framed storefronts that do not comply with requirements or that fail in materials or workmanship within specified warranty period.

**NISQUALLY STATE PARK
NEW FULL SERVICE PARK – PHASE 2**

1. Failures include the following:
 - a. Structural failures including excessive deflection.
 - b. Noise or vibration created by wind and thermal and structural movements.
 - c. Deterioration of metals and other materials beyond normal weathering.
 - d. Water penetration through fixed glazing and framing areas.
 - e. Failure of operating components.
 2. Warranty Period: 5 years from date of Substantial Completion.
- B. Special Finish Warranty, Anodized Finishes: Standard form in which manufacturer agrees to repair finishes or replace aluminum that shows evidence of deterioration of anodized finishes within specified warranty period.
1. Warranty Period: 10 years from date of Substantial Completion

PART 2 - PRODUCTS

2.1 STOREFRONT ASSEMBLIES

- A. Aluminum Storefronts, Dual Thermal Break System:
1. Basis-of-Design Product: Subject to compliance with requirements, provide one of the following:
 - a. Arcadia, Inc.: AG451DT Series.
 - b. EFCO Corporation: XTherm System 403X.
 - c. Kawneer Company Inc.: Trifab 451UT.
 - d. Manko Window Systems, Inc.: 2450XPT Series.
 - e. Oldcastle BuildingEnvelope: Series-3000-XT.
 - f. Tubelite, Inc.: TU24000 Series.
 - g. U.S. Aluminum: Series 45X.
 2. Framing Member Profile: 2 inch by 4-1/2 inch nominal dimension.
 3. Glazing System: Retained mechanically with gaskets on 4 sides.
 4. Glazing Plane: Center.
 5. Glazing Thickness: 1 inch.
 6. Frame Finish: Superior-performance organic finish.

2.2 MANUFACTURERS

- A. Source Limitations: Obtain components of aluminum-framed storefront system and aluminum-framed entrances, including framing and accessories, from single manufacturer.

**NISQUALLY STATE PARK
NEW FULL SERVICE PARK – PHASE 2**

2.3 PERFORMANCE CRITERIA

- A. General Performance: Comply with performance requirements specified, as determined by testing of aluminum-framed storefronts representing those indicated for this Project without failure due to defective manufacture, fabrication, installation, or other defects in construction.
 - 1. Aluminum-framed storefronts shall withstand movements of supporting structure, including twist, column shortening, long-term creep, and deflection from uniformly distributed and concentrated live loads.
 - 2. Failure also includes the following:
 - a. Thermal stresses transferring to building structure.
 - b. Glass breakage.
 - c. Noise or vibration created by wind and thermal and structural movements.
 - d. Loosening or weakening of fasteners, attachments, and other components.

- B. Structural Loads:
 - 1. Wind and Other Design Loads: As indicated on Drawings.

- C. Deflection of Framing Members: At design wind pressure, as follows:
 - 1. Deflection Normal to Wall Plane: Limited to edge of glass in a direction perpendicular to glass plane not exceeding $L/175$ of glass edge length for each individual glazing lite or an amount that restricts edge deflection of individual glazing lites to $3/4$ inch, whichever is less.
 - 2. Deflection Parallel to Glazing Plane: Limited to amount not exceeding that which reduces glazing bite to less than 75 percent of design dimension and that which reduces edge clearance between framing members and glazing or other fixed components directly below them to less than $1/8$ inch, unless dictated otherwise by seismic design requirements.

- D. Structural: Test in accordance with ASTM E330 as follows:
 - 1. When tested at positive and negative wind-load design pressures, storefront assemblies do not evidence deflection exceeding specified limits.
 - 2. When tested at 150 percent of positive and negative wind-load design pressures, storefront assemblies, including anchorage, do not evidence material failures, structural distress, or permanent deformation of main framing members exceeding 0.2 percent of span
 - 3. Test Durations: As required by design wind velocity, but not less than 10 seconds.

- E. Water Penetration under Static Pressure: Test in accordance with ASTM E331 as follows:
 - 1. No evidence of water penetration through fixed glazing and framing areas when tested in accordance with a minimum static-air-pressure differential of 20 percent of positive wind-load design pressure, but not less than 8 lbf/sq. ft.

- F. Seismic Performance: Aluminum-framed storefronts shall withstand the effects of earthquake motions determined in accordance with ASCE 7.

- G. Energy Performance: Certified and labelled by manufacturer for energy performance as follows:

**NISQUALLY STATE PARK
NEW FULL SERVICE PARK – PHASE 2**

1. Thermal Transmittance (U-factor): U-factors for system not more than indicated as determined when tested in accordance with NFRC 100.
 - a. Fixed Glazing and Framing Areas: 0.28 Btu/sq. ft. x h x deg F.
 2. Solar Heat-Gain Coefficient (SHGC): Determined when tested in accordance with NFRC 200.
 - a. Fixed Glazing and Framing Areas: SHGC for system of not more than 0.22.
 3. Air Leakage: Determined when tested in accordance with AAMA/WDMA/CSA 101/I.S.2/A440.
 - a. Fixed Glazing and Framing Areas: Maximum air leakage for system of not more than 0.06 cfm/sq. ft. at static-air-pressure differential of 6.24 lbf/sq. ft. when tested according to ASTM E283.
 4. Condensation-Resistance Factor (CRF): Determined when tested in accordance with AAMA 1503 or NFRC 500.
 - a. Fixed Glazing and Framing Areas: Minimum CRF for system of not less than the following as determined in accordance with AAMA 1503.
 - 1) Minimum CRF for 61 (frame) and 67 (glass).
- H. Thermal Movements: Allow for thermal movements resulting from ambient and surface temperature changes.
1. Temperature Change: 120 deg F, ambient; 180 deg F, material surfaces.
 2. Thermal Cycling: No buckling; stress on glass; sealant failure; excess stress on framing, anchors, and fasteners; or reduction of performance when tested in accordance with AAMA 501.5.
 - a. High Exterior Ambient-Air Temperature: That which produces an exterior metal-surface temperature of 180 deg F.
 - b. Low Exterior Ambient-Air Temperature: 0 deg F.
 - c. Interior Ambient-Air Temperature: 75 deg F.
- 2.4 ALUMINUM-FRAMED STOREFRONT SYSTEMS
- A. Framing Members: Manufacturer's extruded- or formed-aluminum framing members.
1. Exterior Framing Construction: Thermally-broken.
 2. Interior Vestibule Framing Construction: Nonthermal.
 3. Member Wall Thickness: As required to meet structural performance requirements and to support imposed loads.
 4. Aluminum: Alloy and temper recommended by manufacturer for type of use and finish indicated.
 5. Steel Reinforcement: As required by manufacturer to meet structural performance requirements.

**NISQUALLY STATE PARK
NEW FULL SERVICE PARK – PHASE 2**

- B. Backer Plates: Manufacturer's standard, continuous backer plates for framing members, if not integral, where framing abuts adjacent construction.
- C. Brackets and Reinforcements: Manufacturer's standard high-strength aluminum with nonstaining, nonferrous shims for aligning system components.
- D. Thermal Break Material: 2-part chemically-curing, high-density polyurethane, mechanically and adhesively joined to aluminum framing sections
 - 1. Thermal Break Design: Comply with AAMA TIR-A8 and test in accordance with AAMA 505.
 - 2. Minimum Thermal Separation: 1/4 inch.
- E. Entrance Door Systems:
 - 1. As specified in Section 084213 – Aluminum-Framed Entrances.

2.5 GLAZING

- A. Glazing: Comply with Section 088000 – Glazing.
- B. Glazing Gaskets: ASTM C509 or ASTM C864.
 - 1. Manufacturer's standard non-shrinking, weather-resistant, compression-type, replaceable ethylene propylene diene monomer (EPDM).
 - 2. Color: Black, unless indicated otherwise.
- C. Glazing Sealants: As recommended by manufacturer and complying with Section 088000 – Glazing.

2.6 MATERIALS

- A. Aluminum: Alloy and temper recommended by manufacturer for type of use and finish indicated:
 - 1. Sheet and Plate: ASTM B209.
 - 2. Extruded Bars, Rods, Profiles, and Tubes: ASTM B221.
 - 3. Structural Profiles: ASTM B308.
- B. Steel Reinforcement:
 - 1. Structural Shapes, Plates, and Bars: ASTM A36.
 - 2. Cold-Rolled Sheet and Strip: ASTM A1008.
 - 3. Hot-Rolled Sheet and Strip: ASTM A1011.
 - 4. Primer: Manufacturer's standard zinc-rich, corrosion-resistant primer complying with SSPC-PS Guide No. 12.00; applied immediately after surface preparation and pretreatment. Select surface preparation methods according to recommendations in SSPC-SP COM, and prepare surfaces according to applicable SSPC standard.
- C. Recycled Content of Aluminum Components: Postconsumer recycled content plus 1/2 half of preconsumer recycled content not less than 50 percent.

**NISQUALLY STATE PARK
NEW FULL SERVICE PARK – PHASE 2**

- D. Recycled Content of Steel Components: Postconsumer recycled content plus 1/2 half of preconsumer recycled content not less than 50 percent.

2.7 ACCESSORIES

- A. Sidelite Base: Storefront manufacturer's base profile for sidelite conditions.
 - 1. Framing Member Profile: 4-1/2 inch face by 4 inch depth.
 - 2. Frame Finish: Clear anodic finish.
 - 3. Location: Interior storefront assemblies at floor slab conditions.
- B. Transoms: Storefront manufacturer's profile for transom conditions.
 - 1. Framing Member Profile: 1-3/4 inch face by 4 inch depth.
 - 2. Frame Finish: Clear anodic finish.
 - 3. Location: Interior storefront assemblies with single acting doors.
- C. Fasteners and Accessories: Manufacturer's standard corrosion-resistant, nonstaining, nonbleeding fasteners and accessories compatible with adjacent materials.
 - 1. Use self-locking devices where fasteners are subject to loosening or turning out from thermal and structural movements, wind loads, or vibration.
 - 2. Reinforce members as required to receive fastener threads.
 - 3. Exposed Fasteners: Do not use exposed fasteners to greatest extent possible. Where exposed fasteners are unavoidable, provide exposed fasteners with countersunk Phillips screw heads, fabricated from 300 series stainless steel.
 - a. Where framing finish is other than clear anodized, finish exposed fasteners to match framing system.
- D. Anchors: 3-way adjustable anchors with minimum adjustment of 1 inch that accommodate fabrication and installation tolerances in material and finish compatible with adjoining materials and recommended by manufacturer.
- E. Flashing:
 - 1. Exposed: 0.032 inch thick aluminum sheet; ASTM B209, finish to match framing members.
 - 2. Concealed: Dead-soft, 0.018 inch thick stainless steel, ASTM A240 of type recommended by manufacturer.
- F. Bituminous Paint: Cold-applied asphalt-mastic paint containing no asbestos, formulated for 30 mil thickness per coat.

2.8 FABRICATION

- A. Form or extrude aluminum shapes before finishing.

**NISQUALLY STATE PARK
NEW FULL SERVICE PARK – PHASE 2**

- B. Weld in concealed locations to greatest extent possible to minimize distortion or discoloration of finish. Remove weld spatter and welding oxides from exposed surfaces by descaling or grinding.
- C. Fabricate components that, when assembled, have the following characteristics:
 - 1. Profiles that are sharp, straight, and free of defects or deformations.
 - 2. Accurately fitted joints with ends coped or mitered.
 - 3. Physical and thermal isolation of glazing from framing members.
 - 4. Accommodations for thermal and mechanical movements of glazing and framing to maintain required glazing edge clearances.
 - 5. Provisions for field replacement of glazing from exterior.
 - 6. Fasteners, anchors, and connection devices that are concealed from view to greatest extent possible.
- D. Mechanically Glazed Framing Members: Fabricate for flush glazing without projecting stops.
- E. Storefront Framing: Fabricate components for assembly using screw-spline system.
- F. After fabrication, clearly mark components to identify their locations in Project in accordance with Shop Drawings.

2.9 ALUMINUM FINISHES

- A. Superior-Performance Organic Finish, 3-Coat PVDF: Fluoropolymer finish complying with AAMA 2605 and containing not less than 70 percent PVDF resin by weight in both color coat and clear topcoat.
 - 1. Prepare, pretreat, and apply coating to exposed metal surfaces to comply with coating and resin manufacturers' written instructions.
 - 2. Color and Gloss: Match Permafluor Black.
- B. Concealed Steel Items: Prime with iron oxide paint.
- C. Liquid Strippable Coating: Apply in shop to prefinished surfaces to protect finish during fabrication, shipping, and field handling.

PART 3 - EXECUTION

3.1 EXAMINATION

- A. Examine areas, with Installer present, for compliance with requirements for installation tolerances and other conditions affecting performance of Work.
- B. Verify electric power for electronic door controls is available and of correct characteristics.
- C. Proceed with installation only after unsatisfactory conditions have been corrected.

**NISQUALLY STATE PARK
NEW FULL SERVICE PARK – PHASE 2**

3.2 INSTALLATION, GENERAL

- A. Comply with manufacturer's written instructions.
- B. Do not install damaged components.
- C. Fit joints to produce hairline joints free of burrs and distortion.
- D. Rigidly secure nonmovement joints.
- E. Install anchors with separators and isolators to prevent metal corrosion and electrolytic deterioration and to prevent impeding movement of moving joints.
- F. Seal perimeter and other joints watertight unless otherwise indicated.
- G. Metal Protection:
 - 1. Where aluminum is in contact with dissimilar metals, protect against galvanic action by painting contact surfaces with materials recommended by manufacturer for this purpose or by installing nonconductive spacers.
 - 2. Where aluminum is in contact with concrete or masonry, protect against corrosion by painting contact surfaces with bituminous paint.
- H. Set continuous sill members and flashing in full sealant bed, as specified in Section 079200 – Joint Sealants, to produce weathertight installation.
- I. Install joint filler behind sealant as recommended by sealant manufacturer.
- J. Install components plumb and true in alignment with established lines and grades.

3.3 INSTALLATION OF GLAZING

- A. Install glazing as specified in Section 088000 – Glazing.

3.4 ERECTION TOLERANCES

- A. Install aluminum-framed storefronts to comply with the following maximum tolerances:
 - 1. Plumb: 1/8 inch in 10 feet; 1/4 inch in 40 feet.
 - 2. Level: 1/8 inch in 20 feet; 1/4 inch in 40 feet.
 - 3. Alignment:
 - a. Where surfaces abut in line or are separated by reveal or protruding element up to 1/2 inch wide, limit offset from true alignment to 1/16 inch.
 - b. Where surfaces are separated by reveal or protruding element from 1/2 to 1 inch wide, limit offset from true alignment to 1/8 inch.
 - c. Where surfaces are separated by reveal or protruding element of 1 inch wide or more, limit offset from true alignment to 1/4 inch.

**NISQUALLY STATE PARK
NEW FULL SERVICE PARK – PHASE 2**

4. Location: Limit variation from plane to 1/8 inch in 12 feet; 1/2 inch over total length.

3.5 FIELD QUALITY CONTROL

- A. Testing Agency: Owner will engage a qualified testing agency to perform tests and inspections.
- B. Tests and Inspections: Perform the following tests on representative areas of aluminum-framed storefronts.
 1. Test Areas: Minimum 1 bay wide, 20 feet minimum, 40 feet maximum, by 1 story high, in locations approved by Architect.
 2. Do not proceed with installation of next area until test results for previously completed areas show compliance with requirements.
 3. Air Leakage: ASTM E783 at 1.5 times the rate specified for laboratory testing in "Performance Criteria" Article but not more than 0.06 cfm/sq. ft. at a static-air-pressure differential of 6.27 lbf/sq. ft.
 - a. Perform a minimum of 4 tests in areas as directed by Architect.
 - b. Perform tests in each test area as directed by Architect. Perform at least 3 tests, prior to 10, 35, and 70 percent completion.
 4. Water Penetration: ASTM E1105 at minimum uniform and cyclic static-air-pressure differential specified for laboratory testing in "Performance Criteria" Article and shall not evidence water penetration.
 - a. Perform tests in each test area as directed by Architect. Perform at least 3 tests, prior to 10, 35, and 70 percent completion.
 - b. Perform tests in each test area as directed by Architect. Perform at least 3 tests, prior to 10, 35, and 70 percent completion.
- C. Aluminum-framed storefronts will be considered defective if they do not pass tests and inspections.
- D. Prepare test and inspection reports.

3.6 CLEANING

- A. Clean exposed storefront framing surfaces immediately after installation.
 1. Avoid damaging protective coatings and finishes.
 2. Remove excess sealants, glazing materials, dirt, and other substances.
 3. Keep protective films and coverings in place until final cleaning.
- B. Remove and replace glass that has been broken, chipped, cracked, abraded, or damaged during construction period.

**NISQUALLY STATE PARK
NEW FULL SERVICE PARK – PHASE 2**

3.7 PROTECTION

- A. Protect storefront framing and glass surfaces from contact with contaminating substances resulting from construction operations.
 - 1. If contaminating substances do contact storefront framing or glass surfaces, remove contaminants immediately according to manufacturer's written instructions.

END OF SECTION

**NISQUALLY STATE PARK
NEW FULL SERVICE PARK – PHASE 2**

SECTION 085313 – VINYL WINDOWS

PART 1 - GENERAL

1.1 SUMMARY

A. Section Includes:

1. Vinyl-framed windows.

1.2 ADMINISTRATIVE REQUIREMENTS

A. Preinstallation Meeting: Conduct meeting at Project Site.

1. Review and finalize construction schedule and verify availability of materials, Installer's personnel, equipment, and facilities needed to make progress and avoid delays.
2. Review, discuss, and coordinate interrelationship of vinyl windows with other exterior wall components. Include provisions for anchoring, flashing, weeping, sealing perimeters, and protecting finishes.
3. Review and discuss sequence of Work required to construct a watertight and weathertight exterior building envelope.
4. Inspect and discuss condition of substrate and other preparatory Work performed by other trades.

1.3 ACTION SUBMITTALS

A. Product Data: For each type of product.

1. Include construction details, material descriptions, glazing and fabrication methods, dimensions of individual components and profiles, hardware, and finishes for vinyl windows.

B. Shop Drawings: For vinyl windows.

1. Include plans, elevations, sections, hardware, accessories, insect screens, operational clearances, and details of installation, including anchor, flashing, and sealant installation.

C. Samples for Verification: For vinyl windows and components required, prepared on Samples of size indicated below:

1. Main Framing Member: 12 inch long, full-size sections of extrusions with factory-applied color finish.
2. Window Corner Fabrication: 12 by 12 inch long, full-size window corner including full-size sections of extrusions with factory-applied color finish, weatherstripping, and glazing.
3. Exposed Finishes: 2 by 4 inch.
4. Operable Window: Full-size unit with factory-applied finish.
5. Hardware: 2 full-size units with factory-applied finishes.
6. Weatherstripping: 12 inch long sections.

**NISQUALLY STATE PARK
NEW FULL SERVICE PARK – PHASE 2**

- D. Product Schedule: For vinyl windows. Use same designations indicated on Drawings.

1.4 INFORMATIONAL SUBMITTALS

- A. Qualification Data: For manufacturer and Installer.
- B. Product Test Reports: For each type of vinyl window, for tests performed by a qualified testing agency.

1.5 QUALITY ASSURANCE

- A. Manufacturer Qualifications: A manufacturer capable of fabricating vinyl windows that meet or exceed performance requirements indicated and of documenting this performance by test reports and calculations.
- B. Installer Qualifications: An installer acceptable to vinyl window manufacturer for installation of units required for this Project.

1.6 WARRANTY

- A. Manufacturer's Warranty: Manufacturer agrees to repair or replace vinyl windows that fail in materials or workmanship within specified warranty period.
 - 1. Failures include the following:
 - a. Failure to meet performance requirements.
 - b. Structural failures including excessive deflection, water leakage, and air infiltration.
 - c. Faulty operation of movable sash and hardware.
 - d. Deterioration of materials and finishes beyond normal weathering.
 - e. Failure of insulating glass.
 - 2. Warranty Periods: 10 years from date of Substantial Completion.

PART 2 - PRODUCTS

2.1 MANUFACTURERS

- A. Basis-of-Design Product: Subject to compliance with requirements, provide the following:
 - 1. Milgard Manufacturing, Inc.: Trinsic Line Series, V300 Windows.
 - 2. Approved substitution from one of the following:
 - a. Pella Corporation: 250 Series.
 - b. Silver Line Building Products LLC: V3 Series.
 - c. Starline Windows, Ltd.: Series 7100 Vinyl Fixed Window.
 - d. VPI Quality Windows, Inc.: Endurance Series 510-511.
- B. Source Limitations: Obtain vinyl windows from single source from single manufacturer.

**NISQUALLY STATE PARK
NEW FULL SERVICE PARK – PHASE 2**

2.2 PERFORMANCE CRITERIA

- A. Product Standard: Comply with AAMA/WDMA/CSA 101/I.S.2/A440 for definitions and minimum standards of performance, materials, components, accessories, and fabrication unless more stringent requirements are indicated.
 - 1. Window Certification: WDMA certified with label attached to each window.
- B. Performance Class and Grade: AAMA/WDMA/CSA 101/I.S.2/A440 as follows:
 - 1. Minimum Performance Class: LC or CW.
 - 2. Minimum Performance Grade:
 - a. Fixed Units: 30.
 - b. Sliding Units: 25.
- C. Thermal Transmittance: NFRC 100 maximum whole-window U-factor as follows:
 - 1. Fixed Glazing and Framing Areas: 0.26 Btu/sq. ft. x h x deg F.
 - 2. Operable Windows: 0.26 Btu/sq. ft. x h x deg F.
- D. Solar Heat-Gain Coefficient (SHGC): NFRC 200 maximum whole-window SHGC as follows:
 - 1. Fixed: 0.21.
 - 2. Sliding: 0.22
- E. Sound Transmission Class (STC): Rated for not less than the following STC when tested for laboratory sound transmission loss according to ASTM E90 and determined by ASTM E413.
 - 1. Fixed: 0.26-0.29.
 - 2. Sliding: 0.36

2.3 VINYL WINDOWS

- A. Operating Types: Provide the following operating types in locations indicated on Drawings:
 - 1. Fixed.
 - 2. Sliding.
- B. Frames and Sashes: Extruded, hollow, impact-resistant, and UV-stabilized PVC complying with AAMA/WDMA/CSA 101/I.S.2/A440.
 - 1. Integral Colors:
 - a. Exterior: Black.
 - b. Interior: Black.
- C. Glass: Clear annealed glass, ASTM C1036, Type 1, Class 1, q3.
 - 1. Kind: Fully tempered where indicated on Drawings.

**NISQUALLY STATE PARK
NEW FULL SERVICE PARK – PHASE 2**

D. Insulating-Glass Units: ASTM E2190.

1. Glass: ASTM C 1036, Type 1, Class 1, q3.
 - a. Tint: Clear.
 - b. Kind: Fully tempered where indicated on Drawings.
2. Lites: 2.
3. Interspace Content: Fill space between glass lites with argon.
4. Low-E Coating: Pyrolytic or sputtered on second surface.

E. Glazing System: Manufacturer's standard factory-glazing system that produces weathertight seal.

F. Hardware, General: Provide manufacturer's standard hardware fabricated from aluminum, stainless steel, carbon steel complying with AAMA 907, or other corrosion-resistant material compatible with adjacent materials; designed to smoothly operate, tightly close, and securely lock windows, and sized to accommodate sash weight and dimensions.

1. Exposed Hardware Color and Finish: Black or as selected by Architect from manufacturer's full range.

G. Hung Window Hardware:

1. Counterbalancing Mechanism: Complying with AAMA 902, concealed, of size and capacity to hold sash stationary at any open position.
2. Locks and Latches: Allow unobstructed movement of the sash across adjacent sash in direction indicated and operated from inside only. Provide custodial locks.

H. Weatherstripping: Full perimeter weatherstripping for each operable sash unless otherwise indicated.

I. Fasteners: Noncorrosive and compatible with window members, trim, hardware, anchors, and other components.

1. Exposed Fasteners: Do not use exposed fasteners to greatest extent possible. For application of hardware, use fasteners that match finish hardware being fastened.

2.4 INSECT SCREENS

A. Fabricate insect screens to integrate with window frame. Provide screen for each operable exterior sash. Screen wickets are not permitted.

1. Type and Location: Full, inside for project-out; full, outside for project-in sashes.

B. Aluminum Frames: Manufacturer's standard aluminum alloy complying with SMA 1004 or SMA 1201. Fabricate frames with mitered or coped joints or corner extrusions, concealed fasteners, and removable PVC spline/anchor concealing edge of frame.

1. Tubular Framing Sections and Cross Braces: Roll formed from aluminum sheet.
2. Finish for Screens: Matching color and finish of adjacent window frames and sashes.

**NISQUALLY STATE PARK
NEW FULL SERVICE PARK – PHASE 2**

- C. Glass-Fiber Mesh Fabric: 18 by 14 or 18 by 16 mesh of PVC-coated, glass-fiber threads; woven and fused to form a fabric mesh resistant to corrosion, shrinkage, stretch, impact damage, and weather deterioration. Comply with ASTM D3656.

- 1. Mesh Color: Manufacturer's standard.

2.5 FABRICATION

- A. Factory-fabricate vinyl windows in sizes indicated. Include a complete system for installing and anchoring windows.
- B. Factory-glaze vinyl windows.
- C. Weatherstrip each operable sash to provide weathertight installation.
- D. Hardware: Mount hardware through double walls of vinyl extrusions or provide corrosion-resistant reinforcement.
- E. Complete fabrication, assembly, finishing, hardware application, and other Work in factory to greatest extent possible. Disassemble components only as necessary for shipment and installation. Allow for scribing, trimming, and fitting at Project site.

PART 3 - EXECUTION

3.1 EXAMINATION

- A. Examine openings, substrates, structural support, anchorage, and conditions, with Installer present, for compliance with requirements for installation tolerances and other conditions affecting performance of Work.
- B. Verify rough opening dimensions, levelness of sill plate, and operational clearances.
- C. Examine wall flashings, vapor retarders, water and weather barriers, and other built-in components to ensure weathertight window installation.
- D. Proceed with installation only after unsatisfactory conditions have been corrected.

3.2 INSTALLATION

- A. Comply with manufacturer's written instructions for installing windows, hardware, accessories, and other components. For installation procedures and requirements not addressed in manufacturer's written instructions, comply with installation requirements in ASTM E2112.
- B. Install windows level, plumb, square, true to line, without distortion, anchored securely in place to structural support, and in proper relation to wall flashing and other adjacent construction to produce weathertight construction.

**NISQUALLY STATE PARK
NEW FULL SERVICE PARK – PHASE 2**

- C. Install windows and components to drain condensation, water penetrating joints, and moisture migrating within windows to exterior.

3.3 FIELD QUALITY CONTROL

- A. Testing Agency: Owner will engage a qualified testing agency to perform tests and inspections.
 - 1. Testing and inspecting agency will interpret tests and state in each report whether tested work complies with or deviates from requirements.
- B. Testing Services: Testing and inspecting of installed windows shall take place as follows:
 - 1. Testing Methodology: Testing of windows for air infiltration and water resistance shall be performed according to AAMA 502.
 - 2. Air-Infiltration Testing:
 - a. Test Pressure: That required to determine compliance with AAMA/WDMA/CSA 101/I.S.2/A440 performance class indicated.
 - b. Allowable Air-Leakage Rate: 1.5 times applicable AAMA/WDMA/CSA 101/I.S.2/A440 rate for product type and performance class rounded down to 1 decimal place.
 - 3. Water-Resistance Testing:
 - a. Test Pressure: 2/3 times test pressure required to determine compliance with AAMA/WDMA/CSA 101/I.S.2/A440 performance grade indicated.
 - b. Allowable Water Infiltration: No water penetration.
 - 4. Testing Extent: 3 windows of each type as selected by Architect and a qualified independent testing and inspecting agency. Windows shall be tested after perimeter sealants have cured.
 - 5. Test Reports: Prepared according to AAMA 502.
- C. Windows will be considered defective if they do not pass tests and inspections.
- D. Prepare test and inspection reports.

3.4 ADJUSTING

- A. Adjust operating sashes and hardware for a tight fit at contact points and weatherstripping for smooth operation and weathertight closure.

3.5 CLEANING

- A. Clean exposed surfaces immediately after installing windows. Remove excess sealants, glazing materials, dirt, and other substances.
 - 1. Keep protective films and coverings in place until final cleaning.

**NISQUALLY STATE PARK
NEW FULL SERVICE PARK – PHASE 2**

- B. Remove and replace sashes if glass has been broken, chipped, cracked, abraded, or damaged during construction period.

3.6 PROTECTION

- A. Protect window surfaces from contact with contaminating substances resulting from construction operations. If contaminating substances do contact window surfaces, remove contaminants immediately according to manufacturer's written instructions.

END OF SECTION

**NISQUALLY STATE PARK
NEW FULL SERVICE PARK – PHASE 2**

SECTION 087100 – DOOR HARDWARE

PART 1 GENERAL

1.01 SECTION INCLUDES

- A. Hardware for wood, aluminum, hollow metal, and miscellaneous doors as noted.
- B. Hardware for fire-rated doors.
- C. Thresholds.
- D. Smoke and draft control seals.
- E. Weatherstripping and gasketing.

1.02 ADMINISTRATIVE REQUIREMENTS

- A. Coordinate the manufacture, fabrication, and installation of products that door hardware is installed on.
- B. Sequence installation to ensure facility services connections are achieved in an orderly and expeditious manner.
- C. Preinstallation Meeting: Convene a preinstallation meeting one week prior to commencing work of this section; require attendance by affected installers and the following:
 - 1. Architect.
 - 2. Hardware Supplier's Architectural Hardware Consultant (AHC).
 - 3. Hardware Installer.
 - 4. Owner's Security Consultant.
- D. Furnish templates for door and frame preparation to manufacturers and fabricators of products requiring internal reinforcement for door hardware.
- E. Keying Requirements Meeting:
 - 1. Schedule meeting at project site prior to Contractor occupancy.
 - 2. Attendance Required:
 - a. Contractor.
 - b. Owner.
 - c. Hardware Supplier's Architectural Hardware Consultant (AHC).
 - d. Door Hardware Installer.
 - e. Owner's Security Consultant.
 - f. Cylinder Manufacturer's Keying Consultant

**NISQUALLY STATE PARK
NEW FULL SERVICE PARK – PHASE 2**

3. Agenda:
 - a. Establish keying requirements.
 - b. Verify locksets and locking hardware are functionally correct for project requirements.
 - c. Verify that keying and programming complies with project requirements.
 - d. Establish keying submittal schedule and update requirements.
4. Incorporate "Keying Requirements Meeting" decisions into keying submittal upon review of door hardware keying system including, but not limited to, the following:
5. Access control requirements.
6. Key control system requirements.
7. Record minutes and distribute copies within two days after meeting to participants, with two copies to Architect, Owner, participants, and those affected by decisions made.
8. Deliver established keying requirements to manufacturers.

1.03 SUBMITTALS

- A. See Section 013000 - Administrative Requirements and Section 013300 - Submittal Procedures for submittal procedures.
- B. Product Data: Manufacturer's catalog literature for each type of hardware, marked to clearly show products to be furnished for this project, and includes construction details, material descriptions, finishes, and dimensions and profiles of individual components.
- C. Shop Drawings - Door Hardware Schedule: A detailed listing that includes each item of hardware to be installed on each door.
 1. Prepared by or under supervision of Architectural Hardware Consultant (AHC).
 2. Comply with DHI (H&S) using door numbering scheme and hardware set numbers as indicated in Contract Documents.
 - a. Submit in vertical format.
 3. List groups and suffixes in proper sequence.
 4. Include complete description for each door listed.
 5. Include manufacturer's and product names, and catalog numbers; include functions, types, styles, sizes and finishes of each item.
 6. Include account of abbreviations and symbols used in schedule.
- D. Shop Drawings - Electrified Door Hardware: Include diagrams for power, signal, and control wiring for electrified door hardware that include details of interface with building safety and security systems. Provide elevations and diagrams for each electrified door opening as follows:
 1. Prepared by or under supervision of Architectural Hardware Consultant (AHC) and Electrified Hardware Consultant (EHC).
 2. Elevations: Include front and back elevations of each door opening showing electrified devices with connections installed and an operations narrative describing how opening operates from either side at any given time.

**NISQUALLY STATE PARK
NEW FULL SERVICE PARK – PHASE 2**

3. Diagrams: Include point-to-point wiring diagrams that show each device in door opening system with related colored wire connections to each device.
- E. Samples for Verification:
1. Submit 1 sample of hinge, latchset, lockset, and closer illustrating style, color, and finish.
 2. Architect will return full-size samples to Contractor.
 3. Include product description with samples.
- F. Manufacturer's Installation Instructions: Indicate special procedures and perimeter conditions requiring special attention.
- G. Maintenance Data: Include data on operating hardware, lubrication requirements, and inspection procedures related to preventative maintenance.
1. Bitting List: List of combinations as furnished.
- H. Keying Schedule:
1. Submit 3 copies of Keying Schedule in compliance with requirements established during Keying Requirements Meeting unless otherwise indicated.
- I. Warranty: Submit manufacturer's warranty and ensure that forms have been completed in Owner's name and registered with manufacturer.
- J. Maintenance Materials and Tools: Furnish the following for Owner's use in maintenance of project.
1. See Section 016000 - Product Requirements, for additional provisions.
 2. Tools: One set of each special wrench or tool applicable for each different or special hardware component, whether supplied by hardware component manufacturer or not.
- 1.04 QUALITY ASSURANCE
- A. Standards for Fire-Rated Doors: Maintain one copy of each referenced standard on site, for use by Architect and Contractor.
- B. Installer Qualifications: Company specializing in performing work of the type specified for commercial door hardware with at least three years of documented experience.
- C. Supplier Qualifications: Company with certified Architectural Hardware Consultant (AHC) and Electrified Hardware Consultant (EHC) to assist in work of this section.
- 1.05 DELIVERY, STORAGE, AND HANDLING
- A. Package hardware items individually; label and identify each package with door opening code to match door hardware schedule.

**NISQUALLY STATE PARK
NEW FULL SERVICE PARK – PHASE 2**

1.06 WARRANTY

- A. Manufacturer Warranty: Provide manufacturer warranty against defects in material and workmanship for period indicated, from Date of Substantial Completion. Complete forms in Owner's name and register with manufacturer.
1. Closers: 25, minimum.
 2. Exit Devices: 5 years, minimum.
 3. Locksets and Cylinders: 3 years, minimum.
 4. Other Hardware: 2 years, minimum.

PART 2 PRODUCTS

2.01 GENERAL REQUIREMENTS

- A. Provide specified door hardware as required to make doors fully functional, compliant with applicable codes, and secure to extent indicated.
- B. Door Pulls and Push Plates:
1. Provide door pulls and push plates on doors without a lockset, latchset, exit device, or auxiliary lock unless otherwise indicated.
- C. Closers:
1. Provide door closer on each exterior door, unless otherwise indicated.
 2. Provide door closer on each fire-rated and smoke-rated door.
- D. Thresholds:
1. Exterior Applications: Provide at each exterior door, unless otherwise indicated.
- E. Smoke and Draft Control Seals:
1. Provide gasketing for smoke and draft control doors (Indicated as "S" on Drawings) that complies with local codes, requirements of assemblies tested in accordance with UL 1784.
- F. Weatherstripping and Gasketing:
1. Provide weatherstripping on each exterior door at head, jambs, and meeting stiles of door pairs, unless otherwise indicated.
 2. Provide door bottom sweep on each exterior door, unless otherwise indicated.
 3. Fabricate as continuous gasketing, do not cut or notch gasketing material.
- G. Electrically Operated and/or Controlled Hardware: Provide necessary power supplies, power transfer hinges, relays, and interfaces as required for proper operation; provide wiring between hardware and control components and to building power connection in compliance with NFPA 70.

**NISQUALLY STATE PARK
NEW FULL SERVICE PARK – PHASE 2**

H. Fasteners:

1. Provide fasteners of proper type, size, quantity, and finish that comply with commercially recognized standards for proposed applications.
2. Provide machine screws for attachment to reinforced hollow metal and aluminum frames.
3. Provide stainless steel machine screws and lead expansion shields for concrete and masonry substrates.
4. Provide wall grip inserts for hollow wall construction.
5. Fire-Resistance-Rated Applications: Comply with NFPA 80.
6. Concealed Fasteners: Do not use through or sex bolt type fasteners on door panel sides indicated as concealed fastener locations, unless otherwise indicated or required per manufacturer's testing requirements.

2.02 PERFORMANCE REQUIREMENTS

A. Provide door hardware products that comply with the following requirements:

1. Applicable provisions of federal, state, and local codes.
 - a. ICC (IBC).
 - b. NFPA 101.
 - c. Local codes as required.
2. Accessibility: ADA Standards and ICC A117.1.
3. Fire-Resistance-Rated Doors: NFPA 80, listed and labeled by qualified testing agency for fire protection ratings indicated, based on testing at positive pressure in accordance with NFPA 252 or UL 10C.
4. Hardware Preparation for Steel Doors and Steel Frames: BHMA A156.115.
5. Hardware Preparation for Wood Doors with Wood or Steel Frames: BHMA A156.115W.
6. Regulatory and Operational Requirements:
 - a. Provide hardware for all openings, whether specified or not, in compliance with NFPA Standard No. 80, proper operation and local building code requirements. Where required, provide only hardware which has been tested and listed by UL or FM for types and sizes of doors required and complies with requirements of door and door frame labels. Label hardware, as required, for compliance with pressure testing criteria as dictated in IBC.
 - b. Provide hardware which meets or exceeds handicap accessibility per local building code requirements. Conform to the Americans with Disabilities Act (ADA) of 1990 as amended by the D.O.J. September 15, 2010, as adopted by the Authority Having Jurisdiction (AHJ).
7. Products Requiring Electrical Connection: Listed and classified by UL (DIR) as suitable for the purpose specified.

**NISQUALLY STATE PARK
NEW FULL SERVICE PARK – PHASE 2**

2.03 HINGES

A. Manufacturers:

1. Listed in Door Hardware Schedule: Best
2. Substitutions: Hager, McKinney

B. Butt Hinges: As applicable to each item specified.

1. Standard Weight Hinges: Minimum of 2 permanently lubricated non-detachable bearings.
2. Heavy Weight Hinges: Minimum of 4 permanently lubricated bearings on heavy weight hinges.
3. Template screw hole locations.
4. Pins: Easily seated, non-rising pins.
5. UL 10C listed for fire-resistance-rated doors.

C. Finishes: See Door Hardware Schedule.

D. Grades:

1. Butt Hinges: Comply with BHMA A156.1 and BHMA A156.7 for templated hinges.

E. Types:

1. Butt Hinges: Include full mortise hinges.

F. Options: As applicable to each item specified.

G. Quantities:

1. Butt Hinges: 3 hinges per leaves up to 90 inches in height. Add 1 for each additional 30 inches in height or fraction thereof.
 - a. Hinge weight and size unless otherwise indicated in hardware sets:
 - 1) For doors up to 36 inches wide and up to 1-3/4 inches thick provide hinges with a minimum thickness of 0.134 inch and a minimum of 4-1/2 inches in height.
 - 2) For doors from 36 inches wide up to 42 inches wide and up to 1-3/4 inches thick provide hinges with a minimum thickness of 0.145 inch and a minimum of 4-1/2 inches in height.
 - 3) For doors from 42 inches wide up to 48 inches wide and up to 1-3/4 inches thick provide hinges with a minimum thickness of 0.180 inch and a minimum of 5 inches in height.
 - 4) For doors greater than 1-3/4 inches thick provide hinges with a minimum thickness of 0.180 inch and a minimum of 5 inches in height.
2. Continuous Hinges: 1 per door leaf.

**NISQUALLY STATE PARK
NEW FULL SERVICE PARK – PHASE 2**

- H. Applications: At swinging doors.
 - 1. Provide non-removable pins at out-swinging doors with locking hardware and all exterior doors.
- I. Products:
 - 1. Butt Hinges:
 - a. Concealed or Exposed bearing, 5 knuckle.
 - b. Plain Bearing, 5 Knuckle.

2.04 LOCK CYLINDERS

- A. Manufacturers:
 - 1. Listed in Door Hardware Schedule: Best
Substitutions: None – facility standard
- B. Properties:
 - 1. Lock Cylinders: Provide key access on outside of each lock, unless otherwise indicated.
 - a. Provide cylinders from same manufacturer as locking device.
 - b. Provide cams and/or tailpieces as required for locking devices.
 - c. Provide cylinders with appropriate format interchangeable cores where indicated.
- C. Material:
 - 1. Manufacturer's standard corrosion-resistant brass alloy.
- D. Products:
 - 1. Rim/mortise.

2.05 KEYS AND CORES

- A. Manufacturers:
 - 1. Listed in Door Hardware Schedule: Best Cormax Patented
 - 2. Substitutions: None – facility standard
- B. Properties: Complying with guidelines of BHMA A156.28.
 - 1. Provide small format interchangeable core.
 - 2. Provide keying information in compliance with DHI (KSN) standards.
 - 3. Keying Schedule: Arrange for a keying meeting, with Architect, Owner and hardware supplier, and other involved parties to ensure locksets and locking hardware, are functionally correct and keying complies with project requirements.

**NISQUALLY STATE PARK
NEW FULL SERVICE PARK – PHASE 2**

4. Keying: Master keyed.
5. Include construction keying and control keying with removable core cylinders.
6. Do not make brass construction cores and construction control and operating keys a part of Owner's permanent keying system, nor furnish in the same keyway (or key section) as Owner, permanent keying system.
7. Key to new keying system.
8. Supply keys in following quantities:
 - a. Grand Master Keys: 2 each.
 - b. Master Keys: 4 each.
 - c. Construction Master Keys: 2 each.
 - d. Construction Keys: 15 each.
 - e. Construction Control Keys: 2 each.
 - f. Control Keys if New System: 2 each.
 - g. Change Keys: 3 each for each keyed core.
9. Provide key collection envelopes, receipt cards, and index cards in quantity suitable to manage number of keys.
10. Deliver keys with identifying tags to Owner by security shipment direct from manufacturer.
11. Permanent Keys and Cores: Stamped with applicable key marking for identification. Do not include actual key cuts within visual key control marks or codes. Stamp permanent keys "Do Not Duplicate."
12. Include installation of permanent cores and return construction cores to hardware supplier. Construction cores and keys to remain property of hardware supplier.

2.06 MORTISE LOCKS

A. Manufacturers:

1. Listed in Door Hardware Schedule: Best.
2. Substitutions: None – facility standard.

B. Mechanical Locks: Manufacturer's standard.

1. Fitting modified ANSI A115.1 door preparation.
2. Door Thickness Coordination Fitting 1-3/4 inch to 2-1/4 inch thick doors.
3. Latch: Solid, 1-piece, anti-friction, self-lubricating stainless steel.
 - a. Latchbolt Throw: 3/4 inch, minimum.
4. Auxiliary Deadlatch: 1 piece stainless steel, permanently lubricated.
5. Backset: 2-3/4 inch.
6. Lever Trim:
 - a. Functionality: Allow the lever handle to move up to 45 degrees from horizontal position prior to engaging the latchbolt assembly.
 - b. Strength: Locksets outside locked lever designed to withstand minimum 1,400 inch-lbs of torque. In excess of that, a replaceable part will shear. Key from outside and/or inside lever will still operate lockset.
 - c. Spindle: Designed to prevent forced entry from attacking of lever.

**NISQUALLY STATE PARK
NEW FULL SERVICE PARK – PHASE 2**

- d. Independent spring mechanism for each lever.
 - 1) Trim to be self-aligning and thru-bolted.

7. Finishes: See Door Hardware Schedule.

2.07 CYLINDRICAL LOCKS

A. Manufacturers:

- 1. Listed in Door Hardware Schedule: Best.
- 2. Substitutions: None – facility standard.

B. Mechanical Locks:

- 1. Fitting modified ANSI A115.2 door preparation.
- 2. Door Thickness Fit: 1-3/8 inches to 2-1/4 inches thick doors.
- 3. Construction: Hub, side plate, shrouded rose, locking pin to be a 1-piece casting with a shrouded locking lug.

- a. Through-bolted anti-rotational studs.

- 4. Bored Hole: 2-1/8 inch diameter.
- 5. Backset: 2-3/8 inches unless otherwise indicated.
- 6. Latch: Single piece tail-piece construction.

- a. Latchbolt Throw: 1/2 inch, minimum.

7. Cylinders:

- a. Cylinder Core Types: Locks capable of supporting manufacturers' cores, as applicable.

8. Lever Trim:

- a. Style: See Door Hardware Schedule.

C. Finishes: See Door Hardware Schedule.

- 1. Core Faces: Match finish of lockset.

D. Material: Manufacturer's standard for specified lock.

- 1. Critical Latch and Chassis Components: Brass or corrosion-resistance treated steel.

E. Products: Cylindrical locks, including mechanical types.

- 1. 9K (Grade 1).

**NISQUALLY STATE PARK
NEW FULL SERVICE PARK – PHASE 2**

2.08 EXIT DEVICES

A. Manufacturers:

1. Listed in Door Hardware Schedule: Precision
2. Substitutions: Sargent, Von Duprin

B. Properties:

1. Touchpads: "T" style metal touchpads and rail assemblies with matching chassis covers end caps.
2. Latch Bolts: Stainless steel deadlocking with 3/4 inch projection using latch bolt.
3. Cylinder: Include where cylinder dogging or locking trim is indicated.
4. Strike as recommended by manufacturer for application indicated.
5. Sound dampening on touch bar.
6. Dogging:
 - a. Non-Fire-Resistance-Rated Devices: Cylinder dogging.
 - b. Fire-Resistance-Rated Devices, electrical rooms: Manual dogging not permitted.
7. Handing: Field-reversible.

C. Grades: Complying with BHMA A156.3, Grade 1.

D. Standards Compliance:

1. Provide UL (DIR) listed exit device assemblies for fire-resistance-rated doors.
2. Comply with UL 10C.

E. Code Compliance: As required by authorities having jurisdiction in the State in which the Project is located.

2.09 DOOR PULLS AND PUSH PLATES

A. Manufacturers:

1. Listed in Door Hardware Schedule: Trimco
2. Substitutions: Rockwood, Ives

B. Properties:

1. Pull Type: Straight, unless otherwise indicated.
2. Push Plate Type: Flat, with square corners, unless otherwise indicated.

C. Grades: Comply with BHMA A156.6.

D. Material: Stainless steel, unless otherwise indicated.

E. Products: Push-Pull Systems.

**NISQUALLY STATE PARK
NEW FULL SERVICE PARK – PHASE 2**

2.10 CLOSERS

A. Manufacturers:

1. Listed in Door Hardware Schedule: Best QDC100.
2. Substitutions: LCN 4040XP-DEL, Norton 7500 DE.

B. Properties:

1. Surface Mounted Closers: Manufacturer's standard.
 - a. Construction: R14 high silicon aluminum alloy or cast iron.
 - b. Covers:
 - 1) Type: Standard for product selected.
 - (a) Full.
 - 2) Material: Plastic.
 - 3) Finish: Painted.
2. Include the manufacturer's standard adjustable delayed action feature.

C. Grades:

1. Closers: Comply with BHMA A156.4, Grade 1.
 - a. Underwriters Laboratories Compliance:
 - b. Testing Standards Compliance: Meeting requirements of UL 10C for positive pressure.

D. Code Compliance: As required by authorities having jurisdiction in the State in which the Project is located.

E. Types:

1. Rack-and-pinion, surface-mounted. 1-1/2 inches minimum bore.

F. Installation:

1. Mounting: Includes surface mounted installations.
2. Mount closers on non-public side of door and stair side of stair doors unless otherwise noted in hardware sets.
3. At outswinging exterior doors, mount closer on interior side of door.
4. Provide adapter plates, shim spacers, and blade stop spacers as required by frame and door conditions.
5. Where an overlapping astragal is included on pairs of swinging doors, provide coordinator to ensure door leaves close in proper order when automatic flush bolts are used

**NISQUALLY STATE PARK
NEW FULL SERVICE PARK – PHASE 2**

2.11 PROTECTION PLATES

- A. Manufacturers:
 - 1. Listed in Door Hardware Schedule: Trimco
 - 2. Substitutions: Rockwood, Ives
- B. Properties:
 - 1. Plates:
 - a. Kick Plates: Provide along bottom edge of push side of every wood door with closer, except aluminum storefront and glass entry doors, unless otherwise indicated.
 - b. Edges: Beveled, on 4 unless otherwise indicated.
- C. Grades: Comply with BHMA A156.6.
- D. Material: As indicated for each item by BHMA material and finish designation.
 - 1. Metal Properties: Stainless steel.
- E. Installation:
 - 1. Fasteners: Countersunk screw fasteners

2.12 STOPS AND HOLDERS

- A. Manufacturers:
 - 1. Listed in Door Hardware Schedule: Trimco
 - 2. Substitutions: Rockwood, Ives, Don Jo
- B. General: Provide overhead stop/holder when wall or floor stop is not feasible.
- C. Grades:
 - 1. Door Holders, Wall Bumpers, and Floor Stops: Comply with BHMA A156.16 and Resilient Material Retention Test as described in this standard.
- D. Material: Base metal as indicated for each item by BHMA material and finish designation.
- E. Types:
 - 1. Wall Bumpers: Bumper, concave, wall stop.
 - 2. Floor Stops: Provide with rubber bumper floor stop, heavy duty as specified.
- F. Installation:
 - 1. Non-Masonry Walls: Confirm adequate wall reinforcement has been installed to allow lasting installation of wall bumpers.

**NISQUALLY STATE PARK
NEW FULL SERVICE PARK – PHASE 2**

2.13 WEATHERSTRIPPING AND GASKETING

- A. Manufacturers:
 - 1. Listed in Door Hardware Schedule: National Guard
 - 2. Substitutions: Reese, Pemko
- B. Grades: Comply with BHMA A156.22.
- C. Products:
 - 1. Weatherstripping: See Door Hardware Schedule.
 - 2. Door Bottom Seals:
 - a. Door Sweeps: See Door Hardware Schedule.
 - b. Door Shoes: See Door Hardware Schedule.
 - 3. Thresholds will be aluminum with stainless steel fasteners.

2.14 FINISHES

- A. Finishes: Provide door hardware of same finish, unless otherwise indicated.
 - 1. Finish: 626/652; satin chromium plated with brass or steel base material. 630; satin stainless steel and 689; aluminum painted, with any base material

PART 3 EXECUTION

3.01 EXAMINATION

- A. Verify that doors and frames are ready to receive this work; labeled, fire-rated doors and frames are properly installed, and dimensions are as indicated on shop drawings.
- B. Correct all defects prior to proceeding with installation.
- C. Verify that electric power is available to power operated devices and of correct characteristics.

3.02 INSTALLATION

- A. Install hardware in accordance with manufacturer's instructions and applicable codes.
- B. Install hardware using the manufacturer's fasteners provided. Drill and tap all screw holes located in metallic materials. Do not use "Riv-Nuts" or similar products.
- C. Install hardware on fire-rated doors and frames in accordance with applicable codes and NFPA 80.
- D. Install hardware for smoke and draft control doors in accordance with NFPA 105.

**NISQUALLY STATE PARK
NEW FULL SERVICE PARK – PHASE 2**

- E. Use templates provided by hardware item manufacturer.
- F. Do not install surface mounted items until application of finishes to substrate are fully completed.
- G. Wash down masonry walls and complete painting or staining of doors and frames.
- H. Complete finish flooring prior to installation of thresholds.
- I. Door Hardware Mounting Heights: Distance from finished floor to center line of hardware item. As indicated in following list; unless noted otherwise in Door Hardware Schedule or on drawings.
 - 1. For Steel Doors and Frames: Install in compliance with DHI (LOCS) recommendations.
 - 2. For Wood Doors: Install in compliance with DHI WDHS.3 recommendations.
 - 3. Mounting heights in compliance with operational and ADA Standards:
- J. Set exterior door thresholds with full-width bead of elastomeric sealant at each point of contact with floor providing a continuous weather seal; anchor thresholds with stainless steel countersunk screws.
- K. Include in installation for existing doors and frames any necessary field modification and field preparation of doors and frames for new hardware. Provide necessary fillers, reinforcements, and fasteners for mounting new hardware and to cover existing door and frame preparations.

3.03 FIELD QUALITY CONTROL

- A. Perform field inspection and testing under provisions of Section 014000 - Quality Requirements.
- B. Provide an Architectural Hardware Consultant (AHC) to inspect installation and certify that hardware and installation has been furnished and installed in accordance with manufacturer's instructions and as specified.

3.04 ADJUSTING

- A. Adjust work under provisions of Section 017000 - Execution and Closeout Requirements.

3.05 CLEANING

- A. Clean finished hardware in accordance with manufacturer's written instructions after final adjustments have been made.
- B. Clean adjacent surfaces soiled by hardware installation activities.
- C. Replace items that cannot be cleaned to manufacturer's level of finish quality at no additional cost.
- D. See Section 017419 - Construction Waste Management and Disposal, for additional requirements.

**NISQUALLY STATE PARK
NEW FULL SERVICE PARK – PHASE 2**

3.06 PROTECTION

- A. Protect finished Work under provisions of Section 017000 - Execution and Closeout Requirements.
- B. Do not permit adjacent work to damage hardware or finish.

3.07 MAINTENANCE

- A. Approximately six months after the acceptance of hardware in each area, the hardware installer shall:
 - 1. Return to the project and re-adjust every item of hardware to restore proper function of doors and hardware.
 - 2. Consult with and instruct Owner's personnel in recommended additions to the maintenance procedures.
 - 3. Replace hardware items which have deteriorated or failed due to faulty design, materials or installation of hardware units.
 - 4. Prepare a written report of current and predictable problems (of substantial nature) in the performance of the hardware and submit to the Architect.

3.08 MANUFACTURERS

Code	Name
AB	ABH Manufacturing Overhead Stops
BE	Best Access Systems Hinges, Locks, Cylinders, Closers
NA	National Guard Gaskets, Thresholds
PR	Precision Exit Devices
TR	Trimco Door Stops, Flat Goods

3.09 FINISH LIST

Code	Description
626/652	Satin Chromium Plated
630	Satin Stainless Steel
689	Aluminum Painted
GREY	Grey

3.10 OPTIONS

Code	Description
VIN	Occupancy Indicator (Best)
VIB	Double Occupancy Indicator (Best)
CD	Cylinder Dogging (Precision)
LBR	Less Bottom Rod (Precision)
N Mounting	Spanner Through Bolt Attachment (Trimco)
L Mounting	Spanner Back to Back Mounting (Trimco)

**NISQUALLY STATE PARK
NEW FULL SERVICE PARK – PHASE 2**

B4E	Beveled 4 Edges – Kick, Mop & Armor Plates Trimco)
CS	Counter Sinking Of Kick, Mop & Armor Plates (Trimco)
SSMS/EA	Stainless Machine Screws/Expansion Anchors (NGP)

3.08 HARDWARE SCHEDULE

Set #1

3	Hinges	CB191 4.5" x 4.5"	630	BE
1	Lockset	45H-7T14H PATD VIB	626	BE
1	Door Closer	QDC111	689	BE
1	Kick Plate	K0050 10" x 2" LDW B4E CS	630	TR
1	Mop Plate	KM050 6" x 1" LDW B4E CS	630	TR
1	Wall Bumper	1270WV	630	TR
1	Weatherstrip	5075 B Head & Jambs		NA
1	Door Bottom	36 EV		NA
1	Saddle Threshold	426 SSMS/EA		NA

NOTE: Verify threshold application.

Set #2

3	Hinges	CB168 4.5" x 4.5" NRP	652	BE
1	Exit Device	2108 X 4908D CD	630	PR
1	Mortise Cylinder	1E-74 PATD	626	BE
1	Rim Cylinder	12E-72 PATD	626	BE
1	Door Closer	QDC115	689	BE
1	Kick Plate	K0050 10" x 2" LDW B4E CS	630	TR
1	Wall Bumper	1270WV	630	TR
1	Gasketing	5050 B Head & Jambs		NA

Set #3

3	Hinges	CB199 4.5" x 4.5" NRP	630	BE
1	Exit Device	2108 X V4908D CD	630	PR
1	Mortise Cylinder	1E-74 PATD	626	BE
1	Rim Cylinder	12E-72 PATD	626	BE
1	Door Closer	QDC115	689	BE
1	Floor Stop	1214H	626	TR
1	Weatherstrip	5075 B Head & Jambs		NA
1	Door Sweep	200 NA		NA
1	Saddle Threshold	426 SSMS/EA		NA

NOTE: Verify threshold application.

Set #4

3	Hinges	CB179 4.5" x 4.5"	652	BE
1	Push Plate	1001-3	630	TR
1	Pull Plate	1018-3	630	TR
1	Door Closer	QDC115	689	BE
1	Kick Plate	K0050 10" x 2" LDW B4E CS	630	TR
1	Gasketing	5050 B Head & Jambs		NA

**NISQUALLY STATE PARK
NEW FULL SERVICE PARK – PHASE 2**

Set #5

6	Hinges	CB199 4.5" x 4.5" NRP	630	BE
1	Exit Device	2203 CD LBR	630	PR
1	Exit Device	2201 CD LBR	630	PR
2	Mortise Cylinder	1E-74 PATD	626	BE
1	Rim Cylinder	12E-72 PATD	626	BE
2	Door Pull	1191-4 N	630	TR
2	Door Closer	QDC115	689	BE
2	Drop Plate	8Q00471	689	BE
2	Kick Plate	K0050 8" x 2" LDW B4E CS	630	TR
2	Floor Stop	1214H	626	TR
1	Weatherstrip	5075 B Head & Jambs		NA
1	Gasketing Set	A605 A SET		NA
2	Door Sweep	200 NA		NA
1	Saddle Threshold	426 SSMS/EA		NA

NOTE: Verify threshold application.

Set #6

6	Hinges	CB179 4.5" x 4.5"	652	BE
2	Push/Pull Sets	1738 Type L & N Mounting	630	TR
2	Door Closers	QDC115	689	BE
2	Drop Plates	8Q00471	689	BE
2	Kick Plates	K0050 8" x 2" LDW B4E CS	630	TR
2	Wall Bumpers	1270WV	630	TR
1	Gasketing	5050 B Head & Jambs		NA
1	Gasketing Set	A605 A SET		NA

Set #7

3	Hinges	CB191 4.5" x 4.5" NRP	630	BE
1	Lockset	45H-7AB14H PATD	626	BE
1	Door Closer	QDC115	689	BE
1	Kick Plate	K0050 10" x 2" LDW B4E CS	630	TR
1	Floor Stop	1214H	626	TR
1	Weatherstrip	5075 B Head & Jambs		NA
1	Door Sweep	200 NA		NA
1	Saddle Threshold	426 SSMS/EA		NA

NOTE: Verify threshold application.

Set #8

3	Hinges	CB179 4.5" x 4.5"	652	BE
1	Privacy Set	45H-0L14H VIN	626	BE
1	Door Closer	QDC111	689	BE
1	Kick Plate	K0050 10" x 2" LDW B4E CS	630	TR
1	Mop Plate	KM050 6" x 1" LDW B4E CS	630	TR
1	Wall Bumper	1270WV	630	TR
1	Gasketing	5050 B Head & Jambs		NA

**NISQUALLY STATE PARK
NEW FULL SERVICE PARK – PHASE 2**

Set #9

3	Hinges	CB179 4.5" x 4.5"	652	BE
1	Lockset	45H-7D14H PATD	626	BE
1	Kick Plate	K0050 10" x 2" LDW B4E CS	630	TR
1	Wall Bumper	1270WV	630	TR
1	Gasketing	5050 B Head & Jambs		NA

Set #10

3	Hinges	CB179 4.5" x 4.5"	652	BE
1	Lockset	45H-7AT14H PATD	626	BE
1	Wall Bumper	1270WV	630	TR
1	Gasketing	5050 B Head & Jambs		NA

Set #11

3	Hinges	CB179 4.5" x 4.5"	652	BE
1	Lockset	45H-7D14H PATD	626	BE
1	Wall Bumper	1270WV	630	TR
3	Silencers	1229A	GREY	TR

Set #12

3	Hinges	CB179 4.5" x 4.5"	652	BE
1	Lockset	45H-7D14H PATD	626	BE
1	Door Closer	QDC111	689	BE
1	Kick Plate	K0050 10" x 2" LDW B4E CS	630	TR
1	Wall Bumper	1270WV	630	TR
1	Gasketing	5050 B Head & Jambs		NA

Set #13

6	Hinges	CB199 5" x 4.5" NRP	630	BE
2	Manual Flush Bolts	3917-12	626	TR
1	Lockset	45H-7D14H PATD	626	BE
2	Door Closers	QDC115	689	BE
2	Kick Plates	K0050 10" x 2" LDW B4E CS	630	TR
2	Floor Stops	1214H	626	TR
1	Weatherstrip	5075 B Head & Jambs		NA
1	Astragal Gasket	5050 B		NA
2	Door Sweeps	200 NA		NA
1	Saddle Threshold	426 SSMS/EA		NA

NOTE: Inactive leaf for movement of materials only. Astragal on inactive leaf by door manufacturer. Verify threshold application.

Set #14

3	Hinges	CB179 4.5" x 4.5"	652	BE
1	Lockset	45H-7R14H PATD	626	BE
1	Door Closer	QDC111	689	BE
1	Kick Plate	K0050 8" x 2" LDW B4E CS	630	TR
1	Wall Bumper	1270WV	630	TR
1	Gasketing	5050 B Head & Jambs		NA

**NISQUALLY STATE PARK
NEW FULL SERVICE PARK – PHASE 2**

Set #15

1	Cylinder	1E-74 or 12E-72 as required	626	BE
	NOTE: Balance by door manufacturer.			

Set #16

3	Hinges	CB179 4.5" x 4.5"	652	BE
1	Passage Set	9K3-0N14D	626	BE
1	Door Closer	QDC115	689	BE
1	Kick Plate	K0050 10" x 2" LDW B4E CS	630	TR
1	Wall Bumper	1270WV	630	TR
1	Weatherstrip	5075 B Head & Jambs		NA
1	Door Sweep	A607 A		NA
1	Saddle Threshold	411 SSMS/EA		NA

Set #17

3	Hinges	CB191 4.5" x 4.5" NRP	630	BE
1	Lockset	9K3-7AB14D PATD	626	BE
1	Door Closer	QDC115	689	BE
1	Kick Plate	K0050 10" x 2" LDW B4E CS	630	TR
1	Floor Stop	1214H	626	TR
1	Weatherstrip	5075 B Head & Jambs		NA
1	Door Sweep	200 NA		NA
1	Saddle Threshold	426 SSMS/EA		NA

NOTE: Verify threshold application.

Set #18

3	Hinges	CB179 4.5" x 4.5"	652	BE
1	Lockset	45H-7AB14H PATD	626	BE
1	Door Closer	QDC111	689	BE
1	Kick Plate	K0050 10" x 2" LDW B4E CS	630	TR
1	Wall Bumper	1270WV	630	TR
1	Weatherstrip	5075 B Head & Jambs		NA
1	Door Bottom	36 EV		NA
1	Saddle Threshold	426 SSMS/EA		NA

NOTE: Verify threshold application.

Set #19

3	Hinges	CB179 4.5" x 4.5" NRP	652	BE
1	Lockset	9K3-7AB14D PATD	626	BE
1	Overhead Stop	4420 SERIES	630	AB
3	Silencers	1229A	GREY	TR

Set #20

3	Hinges	CB179 4.5" x 4.5"	652	BE
1	Passage Set	9K3-0N14D	626	BE
1	Wall Bumper	1270WV	630	TR
3	Silencers	1229A	GREY	TR

**NISQUALLY STATE PARK
NEW FULL SERVICE PARK – PHASE 2**

Set #21

3	Hinges	CB179 4.5" x 4.5"	652	BE
1	Privacy Set	9K3-0L14D	626	BE
1	Wall Bumper	1270WV	630	TR
3	Silencers	1229A	GREY	TR

Set #22

1	Bypass Hardware Set	BPC150N-00-60		BE
2	Flush Pull	242	626	TR

END OF SECTION

**NISQUALLY STATE PARK
NEW FULL SERVICE PARK – PHASE 2**

SECTION 088000 – GLAZING

PART 1 - GENERAL

1.1 SUMMARY

A. Section Includes:

1. Glass products.
2. Insulating glass.
3. Miscellaneous glazing materials.

1.2 ADMINISTRATIVE REQUIREMENTS

A. Coordination:

1. Coordinate glazing channel dimensions to provide necessary bite on glass, minimum edge and face clearances, and adequate sealant thicknesses, with reasonable tolerances to achieve proper safety margins for glazing retention under each design load case, load case combination, and service condition.

B. Preinstallation Meetings: Conduct meeting at Project site

1. Review and finalize construction schedule and verify availability of materials, Installer's personnel, equipment, and facilities needed to make progress and avoid delays.
2. Review temporary protection requirements for glazing during and after installation.

1.3 ACTION SUBMITTALS

A. Product Data: For each type of product.

B. Glass Samples: For each type of glass product other than clear monolithic vision glass.

1. Size: Not less than 12 sq. in.

C. Glazing Accessory Samples: For gaskets and colored spacers, in 12 inch lengths.

D. Glazing Schedule:

1. List glass types and thicknesses for each size opening and location.
2. Use same designations indicated on Drawings.

E. Delegated-Design Submittal: For glass types, indicating compliance with performance and design criteria.

**NISQUALLY STATE PARK
NEW FULL SERVICE PARK – PHASE 2**

1. Include analysis data signed and sealed by qualified professional engineer responsible for their preparation.

1.4 INFORMATIONAL SUBMITTALS

A. Qualification Data:

1. For manufacturer and Installer of fabricated glass units.
2. For glass testing agency.
3. For professional engineer indicating experience with providing delegated-design engineering services of the kind indicated.

- a. Include documentation that engineer is licensed in state in which Project is located.

- B. Product Certificates: For each type of glass and glazing product, from manufacturer.
- C. Product Test Reports: For fabricated glass, for tests performed by a qualified testing agency.
- D. Preconstruction adhesion and compatibility test report.
- E. Sample Warranties: For special warranties.

1.5 QUALITY ASSURANCE

- A. Fabricated-Glass Manufacturer Qualifications: Qualified manufacturer of fabricated glass units who is approved and certified by primary glass manufacturer.
- B. Installer Qualifications: Qualified glazing contractor for this Project with minimum 3 years of experience and who is certified under the North American Contractor Certification Program (NACC) for Architectural Glass & Metal (AG&M) contractors and who employs glazing technicians certified under the Architectural Glass and Metal Technician (AGMT) certification program.
- C. Delegated-Design Engineer Qualifications: Professional engineer experienced in providing delegated-design engineering services of the kind indicated and is legally qualified to practice in state where Project is located.
- D. Glass Testing Agency Qualifications: Qualified independent testing agency accredited according to the NFRC CAP 1 Certification Agency Program.

1.6 DELIVERY, STORAGE, AND HANDLING

- A. Protect glazing materials in accordance with manufacturer's written instructions. Prevent damage to glass and glazing materials from condensation, temperature changes, direct exposure to sun, or other causes.
- B. Comply with insulating-glass manufacturer's written instructions for venting and sealing units to avoid hermetic seal ruptures due to altitude change.

**NISQUALLY STATE PARK
NEW FULL SERVICE PARK – PHASE 2**

1.7 FIELD CONDITIONS

- A. Environmental Limitations: Do not proceed with glazing when ambient and substrate temperature conditions are outside limits permitted by glazing material manufacturers and when glazing channel substrates are wet from rain, frost, condensation, or other causes.

1.8 WARRANTY

- A. Manufacturer's Special Warranty for Coated-Glass Products: Manufacturer agrees to replace coated-glass units that deteriorate within specified warranty period.
 - 1. Deterioration of coated glass is defined as defects developed from normal use that are not attributed to glass breakage or to maintaining and cleaning coated glass contrary to manufacturer's written instructions.
 - 2. Defects include peeling, cracking, and other indications of deterioration in coating.
 - 3. Warranty Period: 10 years from date of Substantial Completion.
- B. Manufacturer's Special Warranty for Insulating Glass: Manufacturer agrees to replace insulating-glass units that deteriorate within specified warranty period.
 - 1. Deterioration of insulating glass is defined as failure of hermetic seal under normal use that is not attributed to glass breakage or to maintaining and cleaning insulating glass contrary to manufacturer's written instructions.
 - 2. Evidence of failure is the obstruction of vision by dust, moisture, or film on interior surfaces of glass.
 - 3. Warranty Period: 10 years from date of Substantial Completion.

PART 2 - PRODUCTS

2.1 MANUFACTURERS

- A. Source Limitations:
 - 1. Obtain glass from single source from single manufacturer
 - 2. Obtain glazing accessories from single source from single manufacturer for each product and installation method.

2.2 PERFORMANCE CRITERIA

- A. Installed glazing systems shall withstand normal thermal movement and wind and impact loads (where applicable) without failure, including loss or glass breakage attributable to defective manufacture, fabrication, or installation; failure of sealants or gaskets to remain watertight and airtight; deterioration of glazing materials; or other defects in construction.
- B. Delegated-Design: Engage a qualified professional engineer to design glazing.

**NISQUALLY STATE PARK
NEW FULL SERVICE PARK – PHASE 2**

- C. Structural Performance: Glazing shall withstand the following design loads within limits and under conditions indicated determined according to the IBC and ASTM E1300.
 - 1. Design Wind Pressures: As indicated on Drawings.
 - 2. Maximum Lateral Deflection: For glass supported on all 4 edges, limit center-of-glass deflection at design wind pressure to not more than 1/50 times short-side length or 1 inch, whichever is less.

- D. Safety Glazing: Where safety glazing is indicated, provide glazing that complies with 16 CFR 1201, Category II.
 - 1. Provide Kind HS (heat-strengthened) float glass in place of annealed glass where needed to resist thermal stresses induced by differential shading of individual glass lites and to comply with glass design requirements specified in "Performance Criteria" and "Quality Assurance" Articles.
 - 2. Provide Kind FT (fully tempered) glass lites where safety glass is indicated or required by AHJ.

- E. Thermal Performance Properties: Provide glass with performance properties specified, as indicated in manufacturer's published test data, based on procedures indicated below:
 - 1. Monolithic-glass lites properties are based on units with lites 6 mm thick.
 - 2. Insulating-glass units properties, properties are based on units of thickness indicated for overall unit and for each lite.
 - 3. U-Factors: Center-of-glazing values, according to NFRC 100 and based on LBL's WINDOW 5.2 computer program, expressed as Btu/sq. ft. x h x deg F.
 - 4. Solar Heat-Gain Coefficient (SHGC) and Visible Transmittance: Center-of-glazing values, according to NFRC 200 and based on LBL's WINDOW 5.2 computer program.
 - 5. Visible Reflectance: Center-of-glazing values, according to NFRC 300.

2.3 GLASS PRODUCTS, GENERAL

- A. Glazing Publications: Comply with published recommendations of glass product manufacturers and organizations below unless more stringent requirements are indicated. Refer to these publications for glazing terms not otherwise defined in this Section or in referenced standards.
 - 1. NGA Publications: "Glazing Manual."
 - 2. IGMA Publication for Insulating Glass: SIGMA TM-3000, "North American Glazing Guidelines for Sealed Insulating Glass Units for Commercial and Residential Use."

- B. Safety Glazing Labeling: Where safety glazing is indicated, permanently mark glazing with certification label of SGCC or another certification agency acceptable to authorities having jurisdiction.
 - 1. Indicate manufacturer's name, type of glass, thickness, and safety glazing standard with which glass complies on label.

- C. Insulating-Glass Certification Program: Permanently marked either on spacers or on at least 1 component lite of units with appropriate certification label of IgCC.

**NISQUALLY STATE PARK
NEW FULL SERVICE PARK – PHASE 2**

- D. Thickness: Where glass thickness is indicated, it is a minimum. Provide glass that complies with performance requirements and is not less than thickness indicated.
 - 1. Minimum Glass Thickness for Exterior Lites: 6 mm.
- E. Strength: Provide glass types to comply with Performance Criteria Article.
 - 1. Where annealed float glass is indicated, provide annealed float glass, heat-strengthened float glass (Kind HS), or fully tempered float glass (Kind FT).
 - 2. Where heat-strengthened float glass is indicated, provide heat-strengthened float glass (Kind HS) or fully tempered float glass (Kind FT).
 - 3. Where fully tempered float glass is indicated or required by applicable code, provide fully tempered float glass (Kind FT).

2.4 GLASS PRODUCTS

- A. Clear, Annealed Float Glass: ASTM C1036, Type I, Class I (clear), Quality-Q3.
- B. Fully Tempered Float Glass: ASTM C1048, Kind FT (fully tempered), Condition A (uncoated) unless otherwise indicated, Type I, Class 1 (clear), Quality-Q3.
 - 1. Fabrication Process: By horizontal (roller-hearth) process with roll-wave distortion parallel to bottom edge of glass as installed unless otherwise indicated.
- C. Heat-Strengthened Float Glass: ASTM C1048, Kind HS (heat strengthened), Type I, Condition A (uncoated) unless otherwise indicated, Type I, Class 1 (clear), Quality-Q3.
 - 1. Fabrication Process: By horizontal (roller-hearth) process with roll-wave distortion parallel to bottom edge of glass as installed unless otherwise indicated.
- D. Etched Glass: Impact resistant, horizontally tempered glass, conforming to safety requirements of ANSI Z97.1 and ASTM C1048; Type I (transparent glass, flat); Quality Q1 Select Quality.
 - 1. Thickness: 10 mm unless indicated otherwise.
 - 2. Provide finished glass units with Teflon coating to reduce fingerprints
 - 3. Etch Design: Provided by Owner to glass fabricator.
 - 4. Locations: Door Types F1 and F2, and where indicated.

2.5 INSULATING GLASS

- A. Insulating-Glass Units: Factory-assembled units consisting of sealed lites of glass separated by a dehydrated interspace, qualified in accordance with ASTM E2190.
 - 1. Warm-Edge Perimeter Spacer: Spacer manufacturer's system consisting of polypropylene-covered stainless steel, nonmetallic laminate or tube, silicone, with integral desiccant and vapor barrier.
 - a. Spacer Width: 1/2 inch or as required for specified insulating glass unit.

**NISQUALLY STATE PARK
NEW FULL SERVICE PARK – PHASE 2**

- b. Spacer Height: 0.27 inch.
 - c. Corner Construction: Manufacturer's standard corner construction.
 - d. Color: Black or as selected by Architect.
2. Desiccant: Molecular sieve, silica gel, or a blend of both.

2.6 GLAZING TAPES

- A. Back-Bedding Mastic Glazing Tapes: Preformed, butyl-based, 100 percent solids, elastomeric tape; nonstaining and nonmigrating in contact with nonporous surfaces; with or without spacer rod as recommended in writing by tape and glass manufacturers for application indicated; and complying with ASTM C1281 and AAMA 800 for products indicated below:
- 1. Products: Subject to compliance with requirements, provide one of the following:
 - a. CR Laurence: GT Series Butyl Tapes.
 - b. GSSI Sealants: MB-10A or EZ TRIM Sealant Tape.
 - c. ITW Polymers Sealants: Tacky Tape SM5 Series.
 - d. Pecora Corp.: Extru-Seal.
 - e. Tremco: Tremco 440 Tape.
 - f. Approved substitution.
 - 2. Shore Hardness: ASTM 2240; Type A durometer hardness of 15 to 20.
 - 3. AAMA 806.3 tape, for glazing applications in which tape is subject to continuous pressure.

2.7 MISCELLANEOUS GLAZING MATERIALS

- A. Provide products of material, size, and shape complying with referenced glazing standard, with requirements of manufacturers of glass and other glazing materials for application indicated, and with a proven record of compatibility with surfaces contacted in installation.
- B. Cleaners, Primers, and Sealers: Types recommended by gasket manufacturer.
- C. Setting Blocks:
- 1. EPDM or other silicone-compatible material.
 - 2. Shore A Durometer Hardness: ASTM D2240; 85, plus or minus 5.
 - 3. Type recommended in writing by glass manufacturer.
- D. Spacers:
- 1. Neoprene blocks or continuous extrusions.
 - 2. Shore A Durometer Hardness: ASTM D2240; 50 minimum or as required by glass manufacturer to maintain glass lites in place for installation indicated.
 - 3. Type recommended in writing by glass manufacturer.
- E. Edge Blocks:

**NISQUALLY STATE PARK
NEW FULL SERVICE PARK – PHASE 2**

1. EPDM or other silicone-compatible material.
2. Shore A Durometer Hardness: ASTM D2240; as required by glass manufacturer to maintain glass lites in place for installation indicated.
3. Type recommended in writing by glass manufacturer.

F. Glazing U-Channels:

1. Products: Subject to compliance with requirements, provide one of the following:
 - a. C.R. Laurence Co., Inc.: CRL Shallow and Deep Wet/Dry Glaze U-Channels.
 - b. Approved substitution.
2. Material: Aluminum.
3. Glass Size: 9.5 mm.
4. Top Channel: 1 by 1-1/2 inch U-shaped channel.
5. Bottom Channel: 1 by 1 inch U-shaped channel.
6. Finish: Clear anodized.

G. Cylindrical Glazing Sealant Backing: ASTM C1330, Type O (open-cell material), of size and density to control glazing sealant depth and otherwise produce optimum glazing sealant performance.

2.8 FABRICATION OF GLAZING UNITS

- A. Fabricate glazing units in sizes required to fit openings indicated for Project, with edge and face clearances, edge and surface conditions, and bite complying with written instructions of product manufacturer and referenced glazing publications, to comply with system performance requirements.
1. Allow for thermal movements from ambient and surface temperature changes acting on glass framing members and glazing components.
 - a. Temperature Change: 120 deg F, ambient; 180 deg F, material surfaces.

PART 3 - EXECUTION

3.1 EXAMINATION

- A. Examine framing, glazing channels, and stops, with Installer present, for compliance with the following:
1. Manufacturing and installation tolerances, including those for size, squareness, and offsets at corners.
 2. Presence and functioning of weep systems.
 3. Minimum required face and edge clearances.
 4. Minimum required bite.
 5. Effective sealing between joints of glass-framing members.
- B. Proceed with installation only after unsatisfactory conditions have been corrected.

**NISQUALLY STATE PARK
NEW FULL SERVICE PARK – PHASE 2**

3.2 PREPARATION

- A. Clean glazing channels and other framing members receiving glass immediately before glazing.
 - 1. Remove coatings not firmly bonded to substrates.
- B. Examine glazing units to locate exterior and interior surfaces.
 - 1. Label or mark units as needed so that exterior and interior surfaces are readily identifiable.
 - 2. Do not use materials that leave visible marks in completed Work.

3.3 GLAZING, GENERAL

- A. Comply with combined written instructions of manufacturers of glass, sealants, gaskets, and other glazing materials, unless more stringent requirements are indicated, including those in referenced glazing publications.
- B. Protect glass edges from damage during handling and installation.
 - 1. Remove damaged glass from Project site and legally dispose of off Project site.
 - 2. Damaged glass includes glass with edge damage or other imperfections that, when installed, could weaken glass, impair performance, or impair appearance.
- C. Install setting blocks in sill rabbets, sized and located to comply with referenced glazing publications, unless otherwise required by glass manufacturer.
 - 1. Set blocks in thin course of compatible sealant suitable for heel bead.
- D. Do not exceed edge pressures stipulated by glass manufacturers for installing glass lites.
- E. Provide spacers for glass lites where length plus width is larger than 50 inches.
 - 1. Locate spacers directly opposite each other on both inside and outside faces of glass.
 - 2. Install correct size and spacing to preserve required face clearances, unless gaskets and glazing tapes are used that have demonstrated ability to maintain required face clearances and to comply with system performance requirements.
 - 3. Provide 1/8 inch minimum bite of spacers on glass and use thickness equal to sealant width.
 - a. With glazing tape, use thickness slightly less than final compressed thickness of tape.
- F. Provide edge blocking where indicated or needed to prevent glass lites from moving sideways in glazing channel, as recommended in writing by glass manufacturer and according to requirements in referenced glazing publications.
- G. Set glass lites in each series with uniform pattern, draw, bow, and similar characteristics.
- H. Set glass lites with proper orientation so that coatings face exterior or interior as specified.

**NISQUALLY STATE PARK
NEW FULL SERVICE PARK – PHASE 2**

- I. Where wedge-shaped gaskets are driven into one side of channel to pressurize sealant or gasket on opposite side, provide adequate anchorage so gasket cannot walk out when installation is subjected to movement.
- J. Square cut wedge-shaped gaskets at corners and install gaskets in a manner recommended by gasket manufacturer to prevent corners from pulling away; seal corner joints and butt joints with sealant recommended by gasket manufacturer.

3.4 TAPE GLAZING

- A. Position tapes on fixed stops so that, when compressed by glass, their exposed edges are flush with or protrude slightly above sightline of stops.
- B. Install tapes continuously, but not necessarily in one continuous length.
 - 1. Do not stretch tapes to make them fit opening.
- C. Cover vertical framing joints by applying tapes to heads and sills first, then to jambs.
 - 1. Cover horizontal framing joints by applying tapes to jambs, then to heads and sills.
- D. Place joints in tapes at corners of opening with adjoining lengths butted together, not lapped.
- E. Do not remove release paper from tape until right before each glazing unit is installed.
- F. Center glass lites in openings on setting blocks, and press firmly against tape by inserting dense compression gaskets formed and installed to lock in place against faces of removable stops.
 - 1. Start gasket applications at corners and work toward centers of openings.
- G. Application: Interior glazing conditions unless indicated otherwise.

3.5 GASKET GLAZING (DRY)

- A. Cut compression gaskets to lengths recommended by gasket manufacturer to fit openings exactly, with allowance for stretch during installation.
- B. Insert soft compression gasket between glass and frame or fixed stop so it is securely in place with joints miter cut and bonded together at corners.
- C. Installation with Drive-in Wedge Gaskets:
 - 1. Center glass lites in openings on setting blocks, and press firmly against soft compression gasket by inserting dense compression gaskets formed and installed to lock in place against faces of removable stops.
 - 2. Start gasket applications at corners and work toward centers of openings.
 - 3. Compress gaskets to produce a weathertight seal without developing bending stresses in glass.
 - 4. Seal gasket joints with sealant recommended by gasket manufacturer.

**NISQUALLY STATE PARK
NEW FULL SERVICE PARK – PHASE 2**

D. Installation with Pressure-Glazing Stops:

1. Center glass lites in openings on setting blocks, and press firmly against soft compression gasket.
2. Install dense compression gaskets and pressure-glazing stops, applying pressure uniformly to compression gaskets.
3. Start gasket applications at corners and work toward centers of openings.
4. Compress gaskets to produce a weathertight seal without developing bending stresses in glass.
5. Seal gasket joints with sealant recommended by gasket manufacturer.

E. Install gaskets so they protrude past face of glazing stops.

F. Application: Exterior glazing conditions unless indicated otherwise.

3.6 CLEANING

A. Immediately after installation remove nonpermanent labels and clean surfaces.

3.7 PROTECTION

A. Protect exterior glass from damage immediately after installation by attaching crossed streamers to framing held away from glass.

1. Do not apply markers to glass surface.

B. Protect glass from contact with contaminating substances resulting from construction operations.

1. Examine glass surfaces adjacent to or below exterior concrete surfaces at frequent intervals during construction, but not less than once a month, for buildup of dirt, scum, alkaline deposits, or stains.
2. If, despite such protection, contaminating substances do contact with glass, remove substances immediately as recommended in writing by glass manufacturer.
 - a. Remove and replace glass that cannot be cleaned without damage to coatings.
 - b. Remove and replace glass that is damaged during construction period.

C. Wash glass on both exposed surfaces not more than 4 days before date scheduled for inspections that establish date of Substantial Completion.

1. Wash glass as recommended in writing by glass manufacturer.

3.8 MONOLITHIC GLASS SCHEDULE

A. Glass Type (GL-1): Clear, annealed float glass.

1. Minimum Thickness: 6 mm.
2. Safety glazing required.
3. Provide Kind HS glass for field-glazed systems unless indicated otherwise.

**NISQUALLY STATE PARK
NEW FULL SERVICE PARK – PHASE 2**

B. Glass Type (GL-2): Clear, Kind FT fully tempered float glass.

1. Minimum Thickness: 6 mm.
2. Safety glazing required.

3.9 INSULATING GLASS SCHEDULE

A. Insulating Glass Type (IGU-1): Low-E -coated, clear, insulating glass:

1. Overall Unit Thickness: 1 inch.
2. Thickness of Each Glass Lite: 6.0 mm.
3. Outdoor Lite: Annealed float glass.
 - a. Vitro Architectural Glass: Solarban 70 Glass..
 - b. Tint Color: None.
 - c. Low-E Coating: Sputtered on second surface.
4. Interspace Content: 100 percent argon gas.
5. Indoor Lite: Annealed float glass.
 - a. Provide fully tempered lites where indicated and where required by building code.
 - b. Tint Color: None.
6. Transmittance:
 - a. Ultra-Violet Transmittance: 3 percent.
 - b. Visible Light Transmittance: 54 percent.
 - c. Total Solar Energy: 19 percent.
7. Reflectance:
 - a. Visible Light, Exterior: 10 percent.
 - b. Visible Light, Interior: 12 percent.
 - c. Total Solar Energy Reflectance: 12 percent.
8. NFRC U-Values:
 - a. Winter Nighttime: 0.28 Btu maximum.
 - b. Summer Daytime: 0.26 Btu maximum.
9. Shading Coefficient: 0.29.
10. Solar Heat Gain Coefficient (SHGC): 0.26 minimum and 0.40 maximum.
11. Light to Solar Gain (LSG): 2.18.
12. Provide safety glazing labeling.
13. Locations:
 - a. Aluminum-framed entrances.
 - b. Aluminum-framed storefronts.

**NISQUALLY STATE PARK
NEW FULL SERVICE PARK – PHASE 2**

- B. Insulating Glass Type (IGU-1T): Low-E-coated, clear, tempered, insulating glass:
1. Same as IGU-1 except with Kind FT outdoor and indoor lites.
 2. Locations:
 - a. Where IGU-1 is required to be tempered.

END OF SECTION

**NISQUALLY STATE PARK
NEW FULL SERVICE PARK – PHASE 2**

SECTION 092900 – GYPSUM BOARD

PART 1 - GENERAL

1.1 SUMMARY

A. Section Includes:

1. Gypsum board panels.

1.2 ACTION SUBMITTALS

A. Product Data: For each product indicated.

- B. Shop Drawings: Show locations and installation of control and expansion joints, including plans, elevations, sections, details of components, and attachments to other Work..

1.3 QUALITY ASSURANCE

- A. Installer Qualifications: Company specializing in performing gypsum board application and finishing, with minimum 3 years of documented experience.

B. Mockups:

1. Mockup Sizes:

- a. Minimum 100 sq. ft. in surface area for each level of gypsum board finish that will be exposed to view.
2. Apply or install final decoration indicated, including painting, on exposed surfaces for review of mockups.
3. Simulate finished lighting conditions for review of mockups.
4. Approval of field samples does not constitute approval of deviations from Contract Documents contained in field samples unless Architect specifically approves such deviations in writing.
5. Subject to compliance with requirements, approved field samples may become part of completed Work if undisturbed at time of Substantial Completion.

1.4 DELIVERY, STORAGE, AND HANDLING

- A. Store materials inside under cover and keep them dry and protected against weather, condensation, direct sunlight, construction traffic, and other potential causes of damage.

1. Stack panels flat and supported on risers on a flat platform to prevent sagging.

**NISQUALLY STATE PARK
NEW FULL SERVICE PARK – PHASE 2**

1.5 FIELD CONDITIONS

- A. Environmental Limitations: Comply with ASTM C840 requirements or gypsum board manufacturer's written recommendations, whichever are more stringent.
- B. Do not install paper-faced gypsum panels until installation areas are enclosed and conditioned.
- C. Do not install panels that are wet, moisture damaged, or mold damaged.
 - 1. Wet or moisture damaged panels will be discolored, sagging, or irregular shaped.
 - 2. Mold damaged panels will have fuzzy or splotchy surface contamination and discoloration.

PART 2 - PRODUCTS

2.1 GYPSUM BOARD, GENERAL

- A. Size: Provide in maximum lengths and widths available that will minimize joints in each area and that correspond with support system indicated.
- B. Obtain each type of gypsum panel and joint finishing material from single source with resources to provide products of consistent quality in appearance and physical properties.

2.2 INTERIOR GYPSUM BOARD

- A. Gypsum Board, Type X: ASTM C1396; surfaced with 100 percent recycled content paper on front, back, and long edges.
 - 1. Products: Subject to compliance with requirements, provide one of the following:
 - a. Georgia-Pacific Gypsum LLC: ToughRock Fireguard X.
 - b. National Gypsum Company: Gold Bond Brand Fire-Shield.
 - c. USG Corporation: USG Sheetrock Brand Firecode X or EcoSmart Panels Firecode X.
 - d. Approved substitution.
 - 2. Thickness: 5/8 inch.
 - 3. Edges: Tapered and featured (rounded or beveled) for prefilling.
- B. Gypsum Board, Lightweight, Type X: ASTM C1396; surfaced with 100 percent recycled content paper on front, back, and long edges.
 - 1. Products: Subject to compliance with requirements, provide one of the following:
 - a. Georgia-Pacific Gypsum LLC: ToughRock Lite-Weight Fire-Rated Gypsum Board.
 - b. National Gypsum Company: Gold Bond High Strength Fire-Shield 60 Gypsum Board.
 - c. USG Corporation: USG Sheetrock Brand Ultralight Panels Firecode X.
 - d. Approved substitution.
 - 2. Thickness: 5/8 inch.
 - 3. Edges: Tapered and featured (rounded or beveled) for prefilling.

**NISQUALLY STATE PARK
NEW FULL SERVICE PARK – PHASE 2**

4. Surface-Burning Characteristics: Comply with ASTM E84; testing by qualified testing agency.
 - a. Flame-Spread Index: 25 or less.
 - b. Smoke-Developed Index: 25 or less.
 - C. Gypsum Ceiling Board: ASTM C1396.
 1. Products: Subject to compliance with requirements, provide one of the following:
 - a. Georgia-Pacific Gypsum LLC: ToughRock Span 24 Ceiling Board.
 - b. National Gypsum Company: Gold Bond Ceiling Board.
 - c. USG Corporation: USG Sheetrock Brand Ultralight Panels.
 - d. Approved substitution.
 2. Thickness: 1/2 inch.
 3. Long Edges: Tapered.
 - D. Mold-Resistant Gypsum Board: ASTM C1396; with moisture- and mold-resistant core and paper surfaces.
 1. Products: Subject to compliance with requirements, provide one of the following:
 - a. CertainTeed Gypsum; Saint-Gobain: M2Tech Mold and Moisture Board.
 - b. Georgia-Pacific Gypsum LLC: ToughRock Fireguard X Mold-Guard Gypsum Board.
 - c. National Gypsum Company: Gold Bond XP Fire-Shield Gypsum Board.
 - d. USG Corporation: USG Sheetrock Brand Mold Tough Firecode X Panels.
 - e. Approved substitution.
 2. Core: 5/8 inch, Type X.
 3. Long Edges: Tapered.
 4. Mold Resistance: ASTM D3273, score of 10 as rated according to ASTM D3274.
- 2.3 TRIM ACCESSORIES
- A. Interior Trim: ASTM C1047.
 1. Material: Galvanized or aluminum-coated steel sheet, rolled zinc, plastic, or paper-faced galvanized steel sheet.
 2. Shapes: As required for conditions indicated on Drawings.
 - B. Expansion (Control) Joints: Galvanized or aluminum-coated steel sheet, rolled zinc, plastic, or paper-faced galvanized steel sheet control joint with 1/2 to 3/4 inch grounds for drywall finishes. Staple or screw grounds to panel face.
 1. Manufacturers: Subject to compliance with requirements, provide products by one of the following:
 - a. Armstrong World Industries, Inc.
 - b. Fry Reglet Corporation.

**NISQUALLY STATE PARK
NEW FULL SERVICE PARK – PHASE 2**

- c. Gordon Interior Specialties Division, Gordon, Inc.
 - d. USG Corporation.
- 2. Application: Interior gypsum board walls and ceilings.
 - 3. Where fire and sound control joints are indicated, provide fire rated seal behind control joint.

2.4 JOINT TREATMENT MATERIALS

- A. Comply with ASTM C475.
- B. Joint Tape:
 - 1. Interior Gypsum Board: Paper.
- C. Joint Compound for Interior Gypsum Board: For each coat use formulation that is compatible with other compounds applied on previous or for successive coats.
 - 1. Prefilling: At open joints, beveled panel edges, and damaged surface areas, use setting-type taping compound.
 - 2. Embedding and First Coat: For embedding tape and first coat on joints, fasteners, and trim flanges, use setting-type taping compound.
 - a. Use setting-type compound for installing paper-faced metal trim accessories.
 - 3. Fill Coat: For second coat, use drying-type, all-purpose compound.
 - 4. Finish Coat: For third coat, use drying-type, all-purpose compound.
 - 5. Skim Coat: For final coat of Level 5 finish, use drying-type, all-purpose compound.

2.5 AUXILIARY MATERIALS

- A. Provide auxiliary materials that comply with referenced installation standards and manufacturer's written recommendations.
- B. Steel Drill Screws: ASTM C1002 unless otherwise indicated.
 - 1. Use screws complying with ASTM C954 for fastening panels to steel members from 0.033 to 0.112 inch thick.

PART 3 - EXECUTION

3.1 EXAMINATION

- A. Examine areas and substrates, including welded hollow-metal frames and framing, with Installer present, for compliance with requirements and other conditions affecting performance.
- B. Examine panels before installation. Reject panels that are wet, moisture damaged, and mold damaged.

**NISQUALLY STATE PARK
NEW FULL SERVICE PARK – PHASE 2**

- C. Proceed with installation only after unsatisfactory conditions have been corrected.

3.2 INSTALLATION AND FINISHING PANELS, GENERAL

- A. Comply with ASTM C840.
- B. Install ceiling panels across framing to minimize number of abutting end joints and to avoid abutting end joints in central area of each ceiling.
 - 1. Stagger abutting end joints of adjacent panels not less than 1 framing member.
- C. Install panels with face side out.
 - 1. Butt panels together for a light contact at edges and ends with not more than 1/16 inch of open space between panels.
 - 2. Do not force into place.
- D. Locate edge and end joints over supports, except in ceiling applications where intermediate supports or gypsum board back-blocking is provided behind end joints.
 - 1. Do not place tapered edges against cut edges or ends.
 - 2. Stagger vertical joints on opposite sides of partitions.
 - 3. Do not make joints other than control joints at corners of framed openings.
- E. Form control and expansion joints with space between edges of adjoining gypsum panels.
- F. Cover both faces of support framing with gypsum panels in concealed spaces (above ceilings, etc.), except in chases braced internally.
 - 1. Unless concealed application is indicated or required for sound, fire, air, or smoke ratings, coverage may be accomplished with scraps of not less than 8 sq. ft. in area.
 - 2. Fit gypsum panels around ducts, pipes, and conduits.
 - 3. Where partitions intersect structural members projecting below underside of floor/roof slabs and decks, cut gypsum panels to fit profile formed by structural members; allow 1/4 to 3/8 inch wide joints to install sealant.
- G. Isolate perimeter of gypsum board applied to non-load-bearing partitions at structural abutments, except floors.
 - 1. Provide 1/4 to 1/2 inch wide spaces at these locations, and trim edges with edge trim where edges of panels are exposed.
- H. Attachment to Steel Framing: Attach panels so leading edge or end of each panel is attached to open (unsupported) edges of stud flanges first.

**NISQUALLY STATE PARK
NEW FULL SERVICE PARK – PHASE 2**

3.3 INSTALLATION OF INTERIOR GYPSUM BOARD

A. Install interior gypsum board in the following locations:

1. Standard and lightweight, Type X:
 - a. Typical at walls, ceilings, and other gypsum board locations unless other types are indicated.
2. Ceiling Type: Ceiling surfaces unless indicated otherwise.
3. Mold-Resistant Type:
 - a. Walls subject to moisture exposure such as kitchens, toilets, behind drinking fountains, utility areas, janitorial rooms, and as indicated on Drawings.

B. Single-Layer Application:

1. On ceilings, apply gypsum panels before wall/partition board application to greatest extent possible and at right angles to framing unless otherwise indicated.
2. On partitions/walls, apply gypsum panels horizontally (perpendicular to framing) unless otherwise indicated or required by fire-resistance-rated assembly, and minimize end joints.
 - a. Stagger abutting end joints not less than one framing member in alternate courses of panels.
 - b. At stairwells and other high walls, install panels horizontally unless otherwise indicated or required by fire-resistance-rated assembly.
3. On Z-furring members, apply gypsum panels vertically (parallel to framing) with no end joints. Locate edge joints over furring members.
4. Fastening Methods: Apply gypsum panels to supports with steel drill screws.

3.4 INSTALLATION OF TRIM ACCESSORIES

A. For trim with back flanges intended for fasteners, attach to framing with same fasteners used for panels. Otherwise, attach trim per manufacturer's written instructions.

B. Control (Expansion) Joints: Install control joints per ASTM C840, and in specific locations approved by Architect for visual effect.

1. Minimum Control Joint Spacing: 30 feet on center each way.
2. Minimum Joint Spacing Between Panels: 1/4 inch.

C. Interior Trim: Install in the following locations:

1. Cornerbead: Use at outside corners, unless otherwise indicated.

3.5 FINISHING GYPSUM BOARD

A. Treat gypsum board joints, interior angles, edge trim, control joints, penetrations, fastener heads, surface defects, and elsewhere as required to prepare gypsum board surfaces for decoration.

**NISQUALLY STATE PARK
NEW FULL SERVICE PARK – PHASE 2**

- B. Promptly remove residual joint compound from adjacent surfaces.
- C. Prefill open joints, rounded or beveled edges, and damaged surface areas.
- D. Apply joint tape over gypsum board joints, except for trim products specifically indicated as not intended to receive tape.
- E. Gypsum Board Finish Levels: Finish panels to levels indicated below, according to ASTM C840, for locations indicated:
 - 1. Level 0: Where no taping, finishing, or accessories is required.
 - a. Use above suspended ceilings and within other concealed spaces that are not fire rated, sound rated, sound or smoke controlled, or does not serve as an air plenum.
 - 2. Level 2: Provide Level 2 finish at the following conditions:
 - a. Utility areas and behind cabinetry.
 - 3. Level 3: Provide Level 3 finish at the following condition:
 - a. Where indicated to receive medium or heavy textures finish prior to painting.
 - 4. Level 4: Provide Level 4 finish at the following conditions:
 - a. Where indicated as exposed to view and flat finish coat, unless otherwise indicated.
 - 5. Level 5: Provide Level 5 finish at the following condition:
 - a. Where indicated for semi-gloss or gloss finish coats.
 - 6. Primer: Refer to Section 099000 –Painting and Coating.

3.6 FIELD QUALITY CONTROL

- A. Above-Ceiling Observation: Before installing gypsum board ceilings, Architect will conduct an above-ceiling observation and report deficiencies in Work observed. Do not proceed with installation of gypsum board to ceiling support framing until deficiencies have been corrected.
 - 1. Notify Architect 7 days in advance of date and time when Project, or part of Project, will be ready for above-ceiling observation.
 - 2. Before notifying Architect, complete the following in areas to receive gypsum board ceilings:
 - a. Installation of 80 percent of lighting fixtures, powered for operation.
 - b. Installation, insulation, and leak and pressure testing of water piping systems.
 - c. Installation of air-duct systems.
 - d. Installation of air devices.
 - e. Installation of mechanical system control-air tubing.
- B. Installation of ceiling support framing.

**NISQUALLY STATE PARK
NEW FULL SERVICE PARK – PHASE 2**

3.7 PROTECTION

- A. Protect adjacent surfaces from drywall compound and promptly remove from floors and other non-drywall surfaces. Repair surfaces stained, marred, or otherwise damaged during drywall application.
- B. Protect installed products from damage from weather, condensation, direct sunlight, construction, and other causes during remainder of construction period.
- C. Remove and replace panels that are wet, moisture damaged, or mold damaged.

END OF SECTION

**NISQUALLY STATE PARK
NEW FULL SERVICE PARK – PHASE 2**

SECTION 093013 – CERAMIC TILING

PART 1 - GENERAL

1.1 SUMMARY

A. Section Includes:

1. Ceramic Mosaic Floor Tile.
2. Ceramic Wall Tile.

1.2 SUBMITTALS

A. Product Data: Product Data: Submit manufacturer's technical information and installation instructions for materials required, except bulk material. Include certifications and other data to show compliance with these specifications.

B. Samples:

1. Submit 2 Samples for each tile and color required.

1.3 EXTRA MATERIALS

A. Provide a total of two boxes of extra ceramic tile stock of each type and color for the Owner's future use in replacement of damaged tile. The tile shall be provided in unopened factory cartons clearly marked to identify contents.

PART 2 - PRODUCTS

2.1 TILE PRODUCTS

A. ANSI Ceramic Tile Standard: Provide tile that complies with ANSI A137.1 for types, compositions, and other characteristics indicated.

1. Provide tile complying with Standard grade requirements unless otherwise indicated.

B. ANSI Standards for Tile Installation Materials: Provide materials complying with ANSI A108.02, ANSI standards referenced in other Part 2 articles, ANSI standards referenced by TCNA installation methods specified in tile installation schedules, and other requirements specified.

C. Factory Blending: For tile exhibiting color variations within ranges, blend tile in factory and package so tile units taken from one package show same range in colors as those taken from other packages and match approved Samples.

**NISQUALLY STATE PARK
NEW FULL SERVICE PARK – PHASE 2**

2.2 TILE PRODUCTS

A. Basis-of-Design Product: Subject to compliance with requirements, provide the following:

1. Daltile Corporation.

B. Floor and wall tiles will be selected from 2 possible tile color schemes:

1. Color Scheme A:

a. Floor Tile:

1) Dal-Tile, Dapple Gray, DK-326.

a) 2 inch x 2 inch Ceramic Mosaic Tile.

b. Wall Tile:

1) Field Tiles: Dal-Tile, Pepper White, D-147

a) 4-1/4 inch x 4-1/4 inch Dal-Semi-Gloss Glazed Ceramic Tile.

2) Trim Tiles: Dal-Tile, Desert Gray, D-X114

a) 4-1/4 inch x 4-1/4 inch Dal-Semi-Gloss Glazed Ceramic Tile.

2.3 TILE BACKING PANELS

A. Cementitious Backer Units: ANSI A118.9 or ASTM C 1325.

1. Products: Subject to compliance with requirements:

a. “Durock” cement board, or equal.

2. Thickness: 1/2 inch.

2.4 WATERPROOF MEMBRANE

A. General: Standard product that complies with ANSI A118.10 and is recommended by a manufacturer for the application indicated.

1. Polyethylene-Sheet: 6 mil polyethylene film, moisture-resistant. Not waterproof.

2.5 SETTING MATERIALS - MORTAR

A. Portland Cement Mortar (Thickset) Installation Materials: ANSI A108.02.

B. Latex-Portland Cement Mortar (Thin Set): ANSI A118.4.

**NISQUALLY STATE PARK
NEW FULL SERVICE PARK – PHASE 2**

1. Basis-of-Design Product: Subject to compliance with requirements, provide multi-purpose latex modified flexible thin set mortar, “Hydroment” or comparable product by one of the following:
 - a. Boiardi Products; a QEP company.
 - b. Bonsal American; an Oldcastle company.
 - c. Bostik, Inc.
 - d. C-Cure.
 - e. Custom Building Products.
 - f. Jamo Inc.
 - g. Laticrete International, Inc.
 - h. MAPEI Corporation.
 - i. Mer-Kote Products, Inc.
 - j. Southern Grouts & Mortars, Inc.
 - k. Summitville Tiles, Inc.
 - l. TEC; a subsidiary of H. B. Fuller Company.

2.6 GROUT MATERIALS

- A. Grout colors will be selected to coordinate with final selected tile color scheme. Grout colors to be selected from following schemes:
 1. Color Scheme A:
 - a. Floor Tile Grout Color: French Gray (668/368).
 - b. Wall Tile Grout Color: Misty Gray (761).
- B. Standard Cement Grout: ANSI A118.6.
 1. Basis-of-Design Product: Subject to compliance with requirements, provide unsanded Portland cement ceramic tile grout, “Hyroment Dry Tile Grout” or comparable product by one of the following:
 - a. Boiardi Products; a QEP company.
 - b. Bonsal American; an Oldcastle company.
 - c. Bostik, Inc.
 - d. C-Cure.
 - e. Custom Building Products.
 - f. Jamo Inc.
 - g. Laticrete International, Inc.
 - h. MAPEI Corporation.
 - i. Southern Grouts & Mortars, Inc.
 - j. Summitville Tiles, Inc.
 - k. TEC; a subsidiary of H. B. Fuller Company.
- C. Acrylic Latex Admixture: ANSI A118.6.

**NISQUALLY STATE PARK
NEW FULL SERVICE PARK – PHASE 2**

1. Basis-of-Design Product: Subject to compliance with requirements, provide high solids, acrylic latex emulsion additive for “dry tile grout”, “Hydroment 425 Multi-Purpose Acrylic Latex Admixture” or comparable product by one of the following:
 - a. Boiardi Products; a QEP company.
 - b. Bonsal American; an Oldcastle company.
 - c. Bostik, Inc.
 - d. C-Cure.
 - e. Custom Building Products.
 - f. Jamo Inc.
 - g. Laticrete International, Inc.
 - h. MAPEI Corporation.
 - i. Southern Grouts & Mortars, Inc.
 - j. Summitville Tiles, Inc.
 - k. TEC; a subsidiary of H. B. Fuller Company.

2.7 MISCELLANEOUS MATERIALS

- A. Provide other materials, not specifically described but required for a complete and proper installation.

PART 3 - EXECUTION

3.1 EXAMINATION

- A. Examine substrates, areas, and conditions where tile will be installed, with Installer present, for compliance with requirements for installation tolerances and other conditions affecting performance of installed tile.
 1. Verify that substrates for setting tile are firm, dry, clean, free of coatings that are incompatible with tile-setting materials including curing compounds and other substances that contain soap, wax, oil, or silicone; and comply with flatness tolerances required by ANSI A108.01 for installations indicated.
 2. Prior to installing tile, verifying floor slopes toward the drains. Slope shall meet or exceed 1/8 inch per foot. Make sure that flatness variation of surfaces to be tiled does not exceed 1/4 inch per foot. Water test floor slopes in presence of engineer prior to placing tile.

3.2 PREPARATION

- A. Fill cracks, holes, and depressions in concrete substrates for tile floors installed with thin-set mortar with trowelable leveling and patching compound specifically recommended by tile-setting material manufacturer.
- B. Where indicated, prepare substrates to receive waterproofing by applying a reinforced mortar bed that complies with ANSI A108.1A and is sloped 1/4 inch per foot toward drains.

**NISQUALLY STATE PARK
NEW FULL SERVICE PARK – PHASE 2**

- C. Blending: For tile exhibiting color variations, use factory blended tile or blend tiles at Project site before installing.
- D. Field-Applied Temporary Protective Coating: If indicated under tile type or needed to prevent grout from staining or adhering to exposed tile surfaces, precoat them with continuous film of temporary protective coating, taking care not to coat unexposed tile surfaces.

3.3 INSTALLATION

- A. Comply with TCNA installation methods specified in tile installation schedules. Comply with parts of ANSI A108 Series "Specifications for Installation of Ceramic Tile" that are referenced in TCNA installation methods, specified in tile installation schedules, and apply to types of setting and grouting materials used.
 - 1. For the following installations, follow procedures in the ANSI A108 Series of tile installation standards for providing 95 Percent mortar coverage:
 - a. Tile floors in wet areas.
- B. Extend tile Work into recesses and under or behind equipment and fixtures to form complete covering without interruptions unless otherwise indicated. Terminate Work neatly at obstructions, edges, and corners without disrupting pattern or joint alignments.
- C. Accurately form intersections and returns. Perform cutting and drilling of tile without marring visible surfaces. Carefully grind cut edges of tile abutting trim, finish, or built-in items for straight aligned joints. Fit tile closely to electrical outlets, piping, fixtures, and other penetrations so plates, collars, or covers overlap tile.
- D. Jointing Pattern: Lay tile in grid pattern unless otherwise indicated. Lay out tile Work and center tile fields in both directions in each space or on each wall area. Lay out tile Work to minimize the use of pieces that are less than 1/2 of a tile. Provide uniform joint widths unless otherwise indicated.
- E. Joint Widths: Unless otherwise indicated, install tile with the following joint widths:
 - 1. Ceramic Mosaic Tile: 1/16 inch.
 - 2. Glazed Wall Tile: 1/16 inch.
- F. Lay out tile wainscots to dimensions indicated or to next full tile beyond dimensions indicated.
- G. Grout Sealer: Apply grout sealer to cementitious grout joints in tile floors according to grout-sealer manufacturer's written instructions. As soon as grout sealer has penetrated grout joints, remove excess sealer and sealer from tile faces by wiping with soft cloth.
- H. Install cementitious backer boards and treat joints according to ANSI A108.11 and manufacturer's written instructions for type of application indicated. Use latex-portland cement mortar for bonding material unless otherwise directed in manufacturer's written instructions.
- I. Install waterproofing to comply with ANSI A108.13 and manufacturer's written instructions to produce waterproof membrane of uniform thickness and bonded securely to substrate.

**NISQUALLY STATE PARK
NEW FULL SERVICE PARK – PHASE 2**

- J. Install crack isolation membrane to comply with ANSI A108.17 and manufacturer's written instructions to produce membrane of uniform thickness and bonded securely to substrate.

3.4 CEMENTATION BACKER BOARD (CBU)

- A. Verify backing installation prior to installing CBU. Lap and tape seal sheeting joints. Keep joints to a minimum. Use stainless fasteners throughout.
- B. Provide 1/8 inch board spacing at horizontal and vertical joints and corners. Fill 1/8 inch spaces with dry set or latex Portland Cement mortar.
- C. Tape joints and corners with 2 inch glass fiber mesh tape embedded in a skim coat of mortar.
- D. Maximum variation from plane in finished installation shall be 1/8 inch in 8 feet.
- E. Secure CBU with appropriate numbers of corrosion resistant fasteners. Use 1/4 inch "Durock" wood screws for CBU attachment.

3.5 TILE SETTING

- A. Floor Tile:
 - 1. Use method F112: Floor tile shall slope uniformly from walls toward floor drain as shown on Drawings without low areas that collect water. Correct concrete surface irregularities prior to setting floor tile. Water test floors for low spots prior to placing tile.
- B. Wall Tile:
 - 1. Use method TCA W244-2K for walls.

3.6 GROUTING

- A. Wall Tile:
 - 1. Use Hydroment Dry Tile Grout on all wall installations. Fill skips so there are no holes. Use a clean cheese cloth pad, saturated with denatured alcohol, to remove excess grout from tile surfaces.
- B. Floor Tile:
 - 1. Hydroment Ceramic Tile Grout on all floor installations. Fill skips so there are no holes. Completely clean excess grout from tile surfaces.

3.7 CLEANING

- A. Remove grout from tile surfaces within 20 to 30 minutes after grouting. Spray freshly grouted tile Work with water mist to cure surfaces of joints to prevent dust pickup.

**NISQUALLY STATE PARK
NEW FULL SERVICE PARK – PHASE 2**

3.8 SEALING

- A. Thoroughly seal tiled and grouted surfaces after curing and cleaning.

3.9 CURING

- A. After cleaning, place a layer of building paper over surfaces of floors, with edges lapped and sealed.
- B. Allow floors to cure a minimum of 3 days.
- C. Prohibit foot and wheel traffic from tiled floors for at least 7 days after grouting is completed.

3.10 PROTECTION

- A. Protect installed tile Work with Kraft paper or other heavy floor covering during construction period to prevent damage and wear.
- B. Prohibit foot and wheel traffic from using tiles floor for at least 7 days after grouting is completed.
- C. Protect areas subjected to foot traffic and/or rolling trucks, dollies, or other equipment with continuous wood boards or plywood in addition to paper.
- D. Cleaning: Prior to acceptance of Final Completion, clean ceramic tile surfaces so they are free of foreign matter.

END OF SECTION

**NISQUALLY STATE PARK
NEW FULL SERVICE PARK – PHASE 2**

SECTION 095100 – ACOUSTICAL CEILINGS

PART 1 - GENERAL

1.1 SUMMARY

- A. Section Includes:
1. Acoustical panels and exposed suspension systems for ceilings.

1.2 ADMINISTRATIVE REQUIREMENTS

- A. Coordination:
1. Coordinate layout and installation of acoustical panels and suspension system with other construction that penetrates ceilings or is supported by them, including light fixtures, HVAC equipment, fire-suppression system, and partition assemblies.
- B. Preinstallation Meeting: Conduct meeting at Project site.
1. Conduct meeting at least 7 days prior to beginning Work of this Section.
 2. Confirm with AHJ if special inspections are required.

1.3 ACTION SUBMITTALS

- A. Product Data: For each type of product.
- B. Samples for Verification: For each component indicated and for each exposed finish required, prepared on Samples of size indicated below.
1. Acoustical Panel: 2 sets of 6 inch square Samples of each type, color, pattern, and texture.
 2. Exposed Suspension-System Members, Moldings, and Trim: 2 sets of 6 inch long Samples of each type, finish, and color.
- C. Delegated-Design Submittal: For design of seismic restraints and attachment devices.
1. Include design calculations for seismic restraints and analysis data, signed and sealed by qualified professional engineer responsible for their preparation.

1.4 INFORMATIONAL SUBMITTALS

- A. Qualification Data: For professional engineer indicating experience providing delegated-design engineering services of the kind indicated.
1. Include documentation that engineer is licensed in state in which Project is located
- B. Product Test Reports: For each acoustical panel ceiling, for tests performed by manufacturer and witnessed by qualified testing agency.
- C. Evaluation Reports: For each acoustical panel ceiling suspension system and anchor and fastener type, from ICC-ES.

**NISQUALLY STATE PARK
NEW FULL SERVICE PARK – PHASE 2**

1.5 CLOSEOUT SUBMITTALS

- A. Maintenance Data: For finishes to be include in maintenance manuals.

1.6 MAINTENANCE MATERIAL SUBMITTALS

- A. Furnish extra materials that match products installed and that are packaged with protective covering for storage and identified with labels describing contents.
 - 1. Acoustical Ceiling Panels: Full-size panels equal to 5 percent of each ty pe installed, but not less than 2 complete cartons
 - 2. Suspension-System Components: Quantity of each exposed component equal to 2 percent of quantity installed.

1.7 QUALITY ASSURANCE

- A. Manufacturer Qualifications: A firm that specializes in manufacturing of specified acoustical ceiling systems and has been in standard production for a minimum of 3 years.
- B. Installer Qualifications Company specializing in installing specified acoustical ceiling systems with a minimum of 3 years documented experience and authorized and certified by manufacturer to install manufacturer's systems.
- C. Delegated-Design Engineer Qualifications: Professional engineer experienced in providing delegated-design engineering services of the kind indicated and is legally qualified to practice in state where Project is located.

1.8 DELIVERY, STORAGE, AND HANDLING

- A. Deliver acoustical panels, suspension-system components, and accessories to Project site in original, unopened packages and store in fully enclosed, conditioned space where they will be protected against damage from moisture, humidity, temperature extremes, direct sunlight, surface contamination, and other causes.
- B. Before installing acoustical panels, permit to reach room temperature and stabilized moisture content.
- C. Handle acoustical panels carefully to avoid chipping edges or damaging units in any way.

1.9 FIELD CONDITIONS

- A. Environmental Limitations: Do not install acoustical panel ceilings until spaces are enclosed and weatherproof, wet Work in spaces is complete and dry, Work above ceilings is complete, and ambient temperature and humidity conditions are maintained at levels indicated for Project when occupied for its intended use.
 - 1. Pressurized Plenums: Operate ventilation system for not less than 48 hours before beginning acoustical panel ceiling installation.

**NISQUALLY STATE PARK
NEW FULL SERVICE PARK – PHASE 2**

2. Do not install acoustical ceilings until after carpeting and other interior materials that off-gas have been installed and odors and VOC fumes have dissipated.

1.10 WARRANTY

- A. Special Warranty: Manufacturer agrees to repair or replace components of acoustical ceiling system that fail in materials or workmanship within specified warranty period. Warranty is for systems that include both manufacturer's acoustical ceilings and suspension systems.
 1. Failures include the following:
 - a. Acoustical Panels: Visible sagging, warping, shrinking, buckling, or delamination.
 - b. Suspension System: Incurring of more than 50 percent red rust as defined by ASTM B117.
 2. Warranty Period: 15 years from date of Substantial Completion.
 3. Warranty Periods:
 - a. Acoustical Panels: 10 years from date of Substantial Completion.
 - b. Suspension System: 10 years from date of Substantial Completion.
 - c. Ceiling System: 30 years from date of Substantial Completion.

PART 2 - PRODUCTS

2.1 MANUFACTURERS

- A. Source Limitations: Obtain each type of acoustical ceiling panel and its supporting suspension systems, moldings, and accessories from single source from single manufacturer.

2.2 PERFORMANCE CRITERIA

- A. Surface-Burning Characteristics: Class A according to ASTM E84 or UL 723; testing by qualified testing agency. Identify products with appropriate markings of applicable testing agency.
 1. Flame-Spread Index: 25 or less.
 2. Smoke-Developed Index: 50 or less.
- B. Seismic Design Criteria:
 1. Design lateral bracing to withstand effects of earthquake motions in compliance with requirements of ASCE 7 and local jurisdiction for the following zones and categories:
 - a. Zones: 3 and 4.
 - b. Seismic Categories: D, E, and F.
 2. Seismic Separation Joints: Provide seismic separation joints where suspended ceiling areas exceed 2,500 sq. ft. using one of the following methods:

**NISQUALLY STATE PARK
NEW FULL SERVICE PARK – PHASE 2**

- a. Seismic Separation Joint Clips: As specified in this Section.
 - b. Walls and Partitions: Extend walls and partitions a minimum of 6 inches above plane of suspension system grid and laterally brace to structure above.
 - c. Soffits: Extend soffits at minimum to align with bottom plane of suspension system grid and laterally brace to structure above.
3. Exemptions:
- a. Suspended ceiling areas less than or equal to 144 sq. ft. in area and surrounded by walls or partitions connected to structure above are exempt from seismic design requirements.
 - b. Suspended ceiling areas less than 1,000 sq. ft. in area are exempt from lateral force bracing requirements.

2.3 ACOUSTICAL PANELS, GENERAL

- A. Acoustical Panel Standard: Provide manufacturer's standard panels of configuration indicated that comply with ASTM E1264 classifications as designated by types, patterns, acoustical ratings, and light reflectance, unless otherwise indicated.
- B. Antimicrobial Treatment: Manufacturer's standard broad spectrum, antimicrobial formulation that inhibits fungus, mold, mildew, and gram-positive and gram-negative bacteria and showing no mold, mildew, or bacterial growth when tested according to ASTM D3273, ASTM D3274, or ASTM G21 and evaluated according to ASTM D3274 or ASTM G21.

2.4 ACOUSTICAL PANELS

- A. Acoustical Planks, High NRC (ACT-1):
 - 1. Product: Subject to compliance with requirements, provide one of the following:
 - a. Armstrong World Industries, Inc.: Optima Square, Item No. 3154PB.
 - b. CertainTeed Ceilings: Symphony f No. 1346-IOF-1.
 - c. USG Interiors, Inc.: Halcyon Eco 1" Panels, Item No. 9734.
 - 1) Tegular edges need to be squared.
 - d. Approved substitution.
 - 2. Suspension System: SUSP-1.
 - 3. Classification: Provide panels as follows:
 - a. Type and Form: Type XII, glass-fiber base with membrane-faced overlay, Form 2, cloth.
 - b. Pattern: E (lightly textured).
 - 4. Color: White.
 - 5. NRC: Not less than 0.95.

**NISQUALLY STATE PARK
NEW FULL SERVICE PARK – PHASE 2**

6. CAC: NA.
7. Edge/Joint Detail: Square.
 - a. Thickness: 1 inch.
8. Modular Size: 24 by 96 inches.

2.5 METAL SUSPENSION SYSTEMS

- A. Metal Suspension Systems Standard: Provide ceiling manufacturer's standard, direct-hung, metal suspension systems and accessories according to ASTM C635 and designated by type, structural classification, and finish indicated.
 1. High-Humidity Finish: Comply with ASTM C635 requirements for "Coating Classification for Severe Environment Performance" where high-humidity finishes are indicated.
- B. Suspended Ceiling Access: As indicated on Drawings, with initial access openings of size indicated on Drawings and located throughout ceiling within each module formed by main and cross runners, with additional access available by progressively removing remaining acoustical tiles.
 1. Initial Access Opening: In each module, 24 by 24 inches or as indicated on Drawings.
- C. Narrow-Face, Capped, Double- Web, Steel Suspension System (SUSP-2): Main and cross runners roll formed from cold-rolled steel sheet, prepainted, electrolytically zinc coated or hot-dip galvanized, G30 coating designation, with prefinished 9/16 inch wide metal caps on flanges.
 1. Products: Subject to compliance with requirements, provide one of the following:
 - a. Armstrong World Industries, Inc.: Suprafine XL.
 - b. CertainTeed Corp.: 9/16" EZ Stab Elite Narrow System.
 - c. Rockfon: Chicago Metallic 4000 Tempra 9/16".
 - d. USG Interiors, Inc.: Donn Centricitee DXL/DXLT Acoustical Suspension System.
 2. Structural Classification: Heavy-duty system.
 3. End Condition of Cross Runners: Manufacturer's standard end conditions.
 4. Face Design: Flat, flush.
 5. Cap Material: Steel cold-rolled sheet.
 6. Cap Finish: Painted white.

2.6 METAL EDGE MOLDINGS AND TRIM

- A. Roll-Formed, Sheet-Metal Edge Moldings and Trim: Type and profile indicated or, if not indicated, manufacturer's standard moldings for edges and penetrations that comply with seismic design requirements; formed from sheet metal of same material, finish, and color as that used for exposed flanges of suspension system runners.
 1. Provide manufacturer's standard edge moldings that fit acoustical panel edge details and suspension systems indicated and that match width and configuration of exposed runners, unless otherwise indicated.
 2. For circular penetrations of ceiling, provide edge moldings fabricated to diameter required to fit penetration exactly.

**NISQUALLY STATE PARK
NEW FULL SERVICE PARK – PHASE 2**

- B. Perimeter Molding Types: Provide the following products with hemmed edges and prefinished exposed flanges matching color of adjacent suspension system.
 - 1. Angle Molding:
 - a. Mounting Flange: Nominal 1 inch.
 - b. Face Flange: 2 inch, except 15/16 inch face flange may be used if AHJ allows use of seismic end retaining clips.

2.7 ACCESSORIES

- A. Attachment Devices: Size for 5 times design load indicated in ASTM C635, Table 1, "Direct Hung," unless otherwise indicated. Comply with seismic design requirements.
- B. Wire Hangers, Braces, and Ties: Provide wires complying with the following requirements:
 - 1. Zinc-Coated, Carbon-Steel Wire: ASTM A641, Class 1 zinc coating, soft temper.
 - 2. Size: Select wire diameter so its stress at 3 times hanger design load (ASTM C635, Table 1, "Direct Hung") will be less than yield stress of wire, but provide not less than 0.108 inch diameter wire.
- C. Flat Hangers: Mild steel, zinc coated or protected with rust-inhibitive paint; size and type to meet application, seismic, and ceiling flatness requirements.
- D. Angle Hangers: Angles with legs not less than 7/8 inch wide; formed with 0.04 inch thick, galvanized-steel sheet complying with ASTM A653, G90 coating designation; with bolted connections and 5/16 inch diameter bolts.
- E. Seismic End Retaining Clips: Manufacturer's standard seismic clips designed to secure acoustical panels in place during a seismic event.
 - 1. Products: Subject to compliance with requirements, provide one of the following:
 - a. Armstrong World Industries, Inc.: BERC2 Clip.
 - b. USG Interiors, Inc.: Donn ACM7 Seismic Clip.
 - c. Approved substitution.
- F. Seismic Separation Joint Clips: Manufacturer's standard 2-way separation clips designed to provide axial movement of suspension system during a seismic event.
 - 1. Seismic Separation Clips:
 - a. Armstrong World Industries, Inc.: SJMR Series.
 - b. USG Interiors, Inc.: DH2 2-Way Seismic Expansion Joint Clip.
 - c. Approved substitution.
 - 2. Minimum Width: 7/8 inch.

**NISQUALLY STATE PARK
NEW FULL SERVICE PARK – PHASE 2**

- G. Seismic Stabilizer Bars: Manufacturer's standard perimeter stabilizers designed to accommodate seismic forces.
- H. Seismic Compression Struts: Manufacturer's standard compression struts designed to accommodate seismic forces and for lateral force bracing.
 - 1. Materials: Suspension system manufacturer's proprietary compression strut, metal conduit, or metal studs.
 - 2. Sizing: Provide compression struts in sizes required by ASCE 7.

PART 3 - EXECUTION

3.1 EXAMINATION

- A. Examine substrates, areas, and conditions, including structural framing to which acoustical panel ceilings attach or abut, with Installer present, for compliance with requirements specified in this and other Sections that affect ceiling installation and anchorage and with requirements for installation tolerances and other conditions affecting performance of acoustical panel ceilings.
- B. Examine acoustical panels before installation. Reject acoustical panels that are wet, moisture damaged, or mold damaged.
- C. Proceed with installation only after unsatisfactory conditions have been corrected.

3.2 PREPARATION

- A. Measure each ceiling area and establish layout of acoustical panels to balance border widths at opposite edges of each ceiling. Avoid using less-than-half-width panels at borders. Comply with layout shown on reflected ceiling plans.
- B. Layout openings for penetrations centered on penetrating items.

3.3 INSTALLATION OF SUSPENDED ACOUSTICAL CEILINGS

- A. Comply with ASTM C636 and seismic design requirements indicated, according to manufacturer's written instructions, and CISCA's "Ceiling Systems Handbook."
- B. Suspend ceiling hangers from building's structural members and as follows:
 - 1. Install hangers plumb and free from contact with insulation or other objects within ceiling plenum that are not part of supporting structure or of ceiling suspension system.
 - 2. Splay hangers only where required to miss obstructions; offset resulting horizontal forces by bracing, countersplaying, or other equally effective means.
 - 3. Where width of ducts and other construction within ceiling plenum produces hanger spacings that interfere with location of hangers at spacings required to support standard suspension-system members, install supplemental suspension members and hangers in form of trapezes or equivalent devices.

**NISQUALLY STATE PARK
NEW FULL SERVICE PARK – PHASE 2**

4. Secure wire hangers to ceiling-suspension members and to supports above with minimum of 3 tight turns. Connect hangers directly either to structures or to inserts, eye screws, or other devices that are secure and appropriate for substrate and that will not deteriorate or otherwise fail due to age, corrosion, or elevated temperatures.
 5. When steel framing does not permit installation of hanger wires at spacing required, install carrying channels or other supplemental support for attachment of hanger wires.
 6. Space hangers not more than 48 inches on center along each member supported directly from hangers unless otherwise indicated; provide hangers not more than 8 inches from ends of each member.
 7. Size supplemental suspension members and hangers to support ceiling loads within performance limits established by referenced standards and publications.
- C. Secure bracing wires to ceiling suspension members and to supports with minimum of 4 tight turns. Suspend bracing from building's structural members as required for hangers, without attaching to permanent metal forms, steel deck, or steel deck tabs. Fasten bracing wires into concrete with cast-in-place or postinstalled anchors.
- D. Install edge moldings and trim of type indicated at perimeter of acoustical ceiling area and where necessary to conceal edges of acoustical panels.
1. Do not use exposed fasteners, including pop rivets, on moldings and trim.
- E. Install suspension-system runners so they are square and securely interlocked with one another. Remove and replace dented, bent, or kinked members.
- F. Install acoustical panels with undamaged edges and fit accurately into suspension-system runners and edge moldings. Scribe and cut panels at borders and penetrations to provide neat, precise fit.
1. Arrange directionally patterned acoustical panels as follows:
 - a. Install panels with pattern running in one direction parallel to axis of space as indicated.
 2. For reveal-edged panels on suspension-system runners, install panels with bottom of reveal in firm contact with top surface of runner flanges.
 3. Paint cut edges of panel remaining exposed after installation; match color of exposed panel surfaces using coating recommended in writing for this purpose by acoustical panel manufacturer.

3.4 ERECTION TOLERANCES

- A. Suspended Ceilings: Install main and cross runners level to a tolerance of 1/8 inch in 12 feet, non-cumulative.
- B. Moldings and Trim: Install moldings and trim to substrate and level with ceiling suspension system to a tolerance of 1/8 inch in 12 feet, non-cumulative.

3.5 FIELD QUALITY CONTROL

- A. Special Inspections: Owner will engage qualified special inspector to perform the following special inspections:
 1. Compliance of seismic design.

**NISQUALLY STATE PARK
NEW FULL SERVICE PARK – PHASE 2**

- B. Testing Agency: Owner will engage qualified testing agency to perform tests and inspections and prepare test reports.
- C. Perform the following tests and inspections of completed installations of acoustical panel ceiling hangers and anchors and fasteners in successive stages and when installation of ceiling suspension systems on each floor has reached 20 percent completion, but no panels have been installed. Do not proceed with installations of acoustical panel ceiling hangers for next area until test results for previously completed installations show compliance with requirements.
 - 1. Within each test area, testing agency will select 1 of every 10 power-actuated fasteners and postinstalled anchors used to attach hangers to concrete and will test them for 200 pound-force of tension; it will also select 1 of every 2 postinstalled anchors used to attach bracing wires to concrete and will test them for 440 pound-force of tension.
 - 2. When testing discovers fasteners and anchors that do not comply with requirements, testing agency will test those anchors not previously tested until 20 pass consecutively and then will resume initial testing frequency.
- D. Acoustical panel ceiling hangers and anchors and fasteners will be considered defective if they do not pass tests and inspections.
- E. Prepare test and inspection reports.

3.6 ADJUSTING

- A. Adjust sags or twists that develop in ceiling systems and replace materials which are damaged or faulty.

3.7 CLEANING

- A. Clean exposed surfaces of acoustical panel ceilings, including trim, edge moldings, and suspension-system members. Comply with manufacturer's written instructions for cleaning and touchup of minor finish damage.
- B. Remove and replace ceiling components that cannot be successfully cleaned and repaired to permanently eliminate evidence of damage.

END OF SECTION

**NISQUALLY STATE PARK
NEW FULL SERVICE PARK – PHASE 2**

SECTION 095426.13 – SURFACE-MOUNTED WOOD CEILINGS

PART 1 - GENERAL

1.1 SUMMARY

A. Section Includes:

1. Surface-mounted wood ceiling planks.
2. Concealed track and clip system.

1.2 ADMINISTRATIVE REQUIREMENTS

A. Coordination:

1. Coordinate layout and installation of wood ceiling planks and tracks with other construction that penetrates ceilings or is supported by them, including light fixtures, HVAC equipment, fire-suppression system, and partition assemblies.

B. Preinstallation Meeting: Conduct meeting at Project site.

1.3 ACTION SUBMITTALS

A. Product Data: For each type of product including the following:

1. Detailed specification of construction and fabrication.
2. Manufacturer's installation instructions.

B. Shop Drawings: For surface-mounted wood ceilings.

1. Include reflected ceiling plans, sections, and details, drawn to scale, showing the following:
 - a. Wood ceiling patterns and joints.
 - b. Ceiling tracks and clips.
 - c. Method of attaching hangers to building structure and locations of clips.
2. Indicate suspension system grid layout and related dimensions, junctions with other Work or ceiling finishes, and inter-relation of mechanical and electrical items related to ceiling system.
3. Indicated ceiling perimeter and penetrations through ceiling.

C. Samples for Verification: For the following products:

1. Wood Planks: 12 inch long by or full-width of each type, color, and finish.
2. Tracks and Clips: 12 inch long Sample of each type.

**NISQUALLY STATE PARK
NEW FULL SERVICE PARK – PHASE 2**

1.4 CLOSEOUT SUBMITTALS

- A. Maintenance Data: For finishes to include in maintenance manuals.

1.5 MAINTENANCE MATERIAL SUBMITTALS

- A. Furnish extra materials that match products installed and that are packaged with protective covering for storage and identified with labels describing contents.
 - 1. Surface-Mounted-Wood-Ceiling Components: Quantity of each wood-ceiling unit, suspension-system component, accessory, and exposed molding and trim equal to 2 percent of quantity installed.

1.6 QUALITY ASSURANCE

- A. Manufacturer Qualifications: A firm that specializes in manufacturing of specified surface-mounted wood ceiling systems and has been in standard production for a minimum of 3 years.
- B. Installer Qualifications Company specializing in installing specified surface-mounted wood ceiling systems with a minimum of 3 years documented experience and authorized and certified by manufacturer to install manufacturer's systems.
- C. Mockups:
 - 1. Build minimum of 144 sq. ft. mockup of each type of ceiling system where directed by Architect.
 - 2. Verify that mockups comply with manufacturers' instructions. Make adjustments to non-complying components as necessary to bring system into compliance.
 - 3. Do not begin Work of this Section until mockups are accepted by Architect and product manufacturers' representatives.
 - 4. Subject to compliance with requirements, approved mockups may become part of completed Work if undisturbed at time of Substantial Completion.

1.7 DELIVERY, STORAGE, AND HANDLING

- A. Deliver ceiling components and accessories to Project site in original, unopened packages and store them in a fully enclosed, conditioned space where they are protected against damage from moisture, humidity, temperature extremes, direct sunlight, surface contamination, and other causes.
 - 1. Store materials flat and level, raised off of floor.
- B. Handle ceiling components and accessories in a manner that prevents damage.

**NISQUALLY STATE PARK
NEW FULL SERVICE PARK – PHASE 2**

1.8 FIELD CONDITIONS

- A. Environmental Limitations: Do not install wood ceiling system until spaces are enclosed and weatherproof, wet Work in spaces is complete and dry, Work above ceilings is complete, and HVAC system is operating and maintaining temperature and relative humidity at levels planned for building occupants during the remainder of the construction period.
 - 1. Store and acclimatize wood products in spaces where they will be installed for a minimum of 72 hours immediately before ceiling installation.

1.9 WARRANTY

- A. Special Warranty: Manufacturer agrees to repair or replace components of surface-mounted wood ceiling system that fail in materials or workmanship within specified warranty period.
 - 1. Warranty Period: 1 year from date of Substantial Completion.

PART 2 - PRODUCTS

2.1 MANUFACTURERS

- A. Source Limitations: Obtain surface-mounted wood ceiling system, including tracks and clips, from single source from single manufacturer.

2.2 PERFORMANCE CRITERIA

- A. Surface-Burning Characteristics: Comply with ASTM E84; testing by qualified testing agency. Identify products with appropriate markings of applicable testing agency.
 - 1. Flame-Spread Index: Class C according to ASTM E1264.
 - 2. Smoke-Developed Index: 450 or less.

2.3 SURFACE-MOUNTED LINEAR-PLANK CEILINGS

- A. Linear Wood Planks: Prefinished MDF planks.
 - 1. Basis-of-Design Product: Subject to compliance with requirements, provide the following:
 - a. Armstrong Ceilings: WoodHaven Ceiling Planks.
 - b. Approved substitution.
 - 2. Plank Width: 5 inches.
 - 3. Plank Length: 84 inches.
 - 4. Plank Thickness: 3/8 inch.
 - 5. Edge Profile: Tongue and groove.
 - 6. Reveal: Closed.
 - 7. Assembly Style: Flush joint T-bar clip.

**NISQUALLY STATE PARK
NEW FULL SERVICE PARK – PHASE 2**

- B. Linear-Ceiling-Plank Accessories: Linear-ceiling-plank manufacturer's accessories required to provide a complete installation of ceiling in accordance with manufacturer's written installation instructions.
 - 1. Installation Tracks: Manufacturer's standard metal tracks for attaching planks to structure.
 - 2. Attachment Clips: Manufacturer's standard metal clips designed to install directly to metal tracks to secure planks in place.

2.4 FABRICATION

- A. Factory Finish of Linear Wood Planks:
 - 1. Plank Finish: Prefinished with manufacturer's standard coating system.
 - 2. Color: 1264 Rustic Pine.

PART 3 - EXECUTION

3.1 EXAMINATION

- A. Examine substrates, areas, and conditions, to which linear wood planks attach or abut, with Installer present, for compliance with requirements specified in this and other Sections that affect ceiling installation and anchorage and with requirements for installation tolerances and other conditions affecting performance of linear wood ceilings.
- B. Proceed with installation only after unsatisfactory conditions have been corrected.

3.2 PREPARATION

- A. Before installation, condition interior architectural woodwork to humidity conditions in installation areas for not less than 72 hours prior to beginning of installation.
- B. Measure each ceiling area and establish layout of linear wood ceilings to balance border widths at opposite edges of each ceiling. Avoid using less-than-half-width or -length panels at borders, and comply with layout shown on Drawings.

3.3 INSTALLATION

- A. Comply with manufacturer's written instructions.
- B. Install tracks so they are aligned and securely interlocked with one another. Remove and replace dented, bent, or kinked members.
- C. Cut linear wood planks for accurate fit at borders and at interruptions and penetrations by other Work through ceilings.

**NISQUALLY STATE PARK
NEW FULL SERVICE PARK – PHASE 2**

- D. Install linear wood ceilings in compliance with manufacturer's installation instructions.
 - 1. Align joints in adjacent courses to form uniform, straight joints parallel to room axis in both directions unless otherwise indicated.
 - 2. Fit adjoining units to form flush, tight joints. Scribe and cut units for accurate fit at borders and around construction penetrating ceiling.

3.4 FIELD QUALITY CONTROL

- A. Special Inspections: Owner will engage qualified special inspector to perform the following special inspections:
 - 1. Compliance of seismic design.
- B. Acoustical panel tracks, clips, and fasteners will be considered defective if they do not pass tests and inspections.

3.5 ADJUSTING

- A. Adjust sags or twists that develop in ceiling systems and replace materials which are damaged or faulty.

3.6 CLEANING

- A. After Completion of Installation: Clean soiled surfaces.
 - 1. Remove and reinstall improperly installed material.
 - 2. Touch-up moderately damaged wood surfaces with same finish materials as in factory.
 - 3. Remove severely damaged material, discolored material, and moderately damaged material that cannot be properly touch-up finished and replace with new material.

END OF SECTION

**NISQUALLY STATE PARK
NEW FULL SERVICE PARK – PHASE 2**

SECTION 096513 – RESILIENT BASE AND ACCESSORIES

PART 1 - GENERAL

1.1 SUMMARY

A. Section Includes:

1. Thermoset-rubber base.

1.2 ACTION SUBMITTALS

A. Product Data: For each type of product.

B. Samples for Verification: For each type of product indicated and for each color, texture, and pattern required in manufacturer's standard-size Samples, but not less than 6 inches long.

C. Product Schedule: For resilient base and accessory products. Use same designations indicated on Drawings.

1.3 MAINTENANCE MATERIAL SUBMITTALS

A. Furnish extra materials, from the same product run, that match products installed and that are packaged with protective covering for storage and identified with labels describing contents.

1. Furnish not less than 10 linear feet for every 500 linear feet or fraction thereof, of each type, color, pattern, and size of resilient product installed.

1.4 DELIVERY, STORAGE, AND HANDLING

A. Store resilient products and installation materials in dry spaces protected from the weather, with ambient temperatures maintained within range recommended by manufacturer, but not less than 50 deg F or more than 90 deg F.

1.5 FIELD CONDITIONS

A. Ambient Conditions:

1. Maintain ambient temperatures within range recommended by manufacturer, but not less than 70 deg F or more than 95 deg F, in spaces to receive resilient products during the following time periods:
 - a. 48 hours before installation.
 - b. During installation.
 - c. 48 hours after installation.

**NISQUALLY STATE PARK
NEW FULL SERVICE PARK – PHASE 2**

2. Until Substantial Completion, maintain ambient temperatures within range recommended by manufacturer, but not less than 55 deg F or more than 95 deg F.
3. Install resilient products after other finishing operations, including painting, have been completed.

PART 2 - PRODUCTS

2.1 THERMOPLASTIC-RUBBER BASE

A. Thermoplastic-Rubber Base:

1. Products: Subject to compliance with requirements, provide products specified in Material and Finish Legend on Drawings or approved substitution.

B. Product Standard: ASTM F1861, Type TP (rubber, thermoplastic).

1. Products: Subject to compliance with requirements, provide one of the following:
 - a. Armstrong Flooring, Inc.: Coved Wall Base.
 - b. Flexco Floors: Flexco Base 2000 Thermoplastic Rubber (TP) Wall Base.
 - c. Mannington Commercial: BurkeBase Rubber Wall BaseType TP.
 - d. Roppe Corporation: 700 Series TP Rubber Wall Base.
 - e. Tarkett North America: Traditional Thermoplastic (TP) Rubber Wall Base.
 - f. Approved substitution.
2. Group: I (solid, homogeneous).
3. Style and Location:
 - a. Style B, Cove: Provide in areas with resilient or other hard surface flooring unless indicated otherwise.
4. Minimum Thickness: 0.125 inch.
5. Height: 6 inches.
6. Lengths: Coils in manufacturer's standard length.
7. Inside and Outside Corners: Job formed.
8. Finish: Satin.
9. Color: Black.

2.2 INSTALLATION MATERIALS

- A. Trowelable Leveling and Patching Compounds: Latex-modified, portland-cement-based or blended hydraulic-cement-based formulation provided or approved by resilient-product manufacturer for applications indicated.
- B. Adhesives: Water-resistant type recommended by resilient-product manufacturer for resilient products and substrate conditions indicated.

**NISQUALLY STATE PARK
NEW FULL SERVICE PARK – PHASE 2**

PART 3 - EXECUTION

3.1 EXAMINATION

- A. Examine substrates, with Installer present, for compliance with requirements for maximum moisture content and other conditions affecting performance of Work.
 - 1. Verify that finishes of substrates comply with tolerances and other requirements specified in other Sections and that substrates are free of cracks, ridges, depressions, scale, and foreign deposits that might interfere with adhesion of resilient products.
- B. Proceed with installation only after unsatisfactory conditions have been corrected.
 - 1. Installation of resilient products indicates acceptance of surfaces and conditions.

3.2 PREPARATION

- A. Prepare substrates according to manufacturer's written instructions to ensure adhesion of resilient products.
- B. Fill cracks, holes, and depressions in substrates with trowelable leveling and patching compound; remove bumps and ridges to produce a uniform and smooth substrate.
- C. Do not install resilient products until materials are the same temperature as space where they are to be installed.
 - 1. At least 48 hours in advance of installation, move resilient products and installation materials into spaces where they will be installed.
- D. Immediately before installation, sweep and vacuum clean substrates to be covered by resilient products.

3.3 INSTALLATION OF RESILIENT BASE

- A. Comply with manufacturer's written instructions for installing resilient base.
- B. Apply resilient base to walls, columns, pilasters, casework and cabinets in toe spaces, and other permanent fixtures in rooms and areas where base is required.
- C. Install resilient base in lengths as long as practical without gaps at seams and with tops of adjacent pieces aligned.
- D. Tightly adhere resilient base to substrate throughout length of each piece, with base in continuous contact with horizontal and vertical substrates.
- E. Do not stretch resilient base during installation.

**NISQUALLY STATE PARK
NEW FULL SERVICE PARK – PHASE 2**

- F. On masonry surfaces or other similar irregular substrates, fill voids along top edge of resilient base with manufacturer's recommended adhesive filler material.
- G. Preformed Corners: Install preformed corners before installing straight pieces.
- H. Job-Formed Corners:
 - 1. Outside Corners: Use straight pieces of maximum lengths possible and form with returns not less than 3 inches in length.
 - a. Form without producing discoloration (whitening) at bends.
 - 2. Inside Corners: Use straight pieces of maximum lengths possible and form with returns not less than 3 inches in length.
 - a. Miter or cope corners to minimize open joints.

3.4 CLEANING

- A. Comply with manufacturer's written instructions for cleaning and protecting resilient products.
- B. Perform the following operations immediately after completing resilient-product installation:
 - 1. Remove adhesive and other blemishes from surfaces.

3.5 PROTECTION

- A. Protect resilient products from mars, marks, indentations, and other damage from construction operations and placement of equipment and fixtures during remainder of construction period.

END OF SECTION

**NISQUALLY STATE PARK
NEW FULL SERVICE PARK – PHASE 2**

SECTION 096516 – RESILIENT SHEET FLOORING

PART 1 - GENERAL

1.1 SUMMARY

A. Section Includes:

1. Resilient sheet floor covering.

1.2 ACTION SUBMITTALS

A. Product Data: For each type of product.

B. Shop Drawings: For each type of resilient sheet flooring.

1. Include sheet flooring layouts, locations of seams, edges, columns, doorways, enclosing partitions, built-in furniture, cabinets, and cutouts.
2. Show details of special patterns.

C. Samples for Verification: For each type of resilient sheet flooring, in manufacturer's standard size, but not less than 6 by 9 inch sections of each color, texture, and pattern required.

1. For heat-welding bead, manufacturer's standard-size Samples, but not less than 9 inches long, of each color required.

D. Welded Seam Samples: For seamless-installation technique indicated and for each resilient sheet flooring product, color, and pattern required; with seam running lengthwise and in center of 6 by 9 inch Sample applied to a rigid backing and prepared by Installer for this Project.

E. Product Schedule: For resilient sheet flooring, use same designations indicated on Drawings

1.3 INFORMATIONAL SUBMITTALS.

A. Qualification Data: For qualified installer.

B. Product Test Reports: Based on evaluation of comprehensive tests performed by a qualified testing agency, for floor coverings.

C. Moisture and alkali test results.

D. Slip-Resistance Certification: Manufacturer's certificate indicating that products meet or exceed specified requirements.

**NISQUALLY STATE PARK
NEW FULL SERVICE PARK – PHASE 2**

1.4 CLOSEOUT SUBMITTALS

- A. Maintenance Data: For each type of resilient sheet flooring to include in maintenance manuals.

1.5 MAINTENANCE MATERIAL SUBMITTALS

- A. Furnish extra materials, from same product run, that match products installed and that are packaged with protective covering for storage and identified with labels describing contents.
 - 1. Resilient Sheet Flooring: Furnish quantity not less than 10 linear feet for every 500 linear feet or fraction thereof, in roll form and in full roll width for each color, pattern, and type of floor covering installed.

1.6 QUALITY ASSURANCE

- A. Installer Qualifications: An entity that employs installers and supervisors who are competent in techniques required by manufacturer for floor covering installation and seaming method indicated.
 - 1. Engage an installer who employs workers for this Project who are trained or certified by resilient sheet flooring manufacturer for installation techniques required.

1.7 DELIVERY, STORAGE, AND HANDLING

- A. Store resilient sheet flooring and installation materials in dry spaces protected from weather, with ambient temperatures maintained within range recommended by manufacturer, but not less than 50 deg F or more than 90 deg F. Store rolls upright.

1.8 FIELD CONDITIONS

- A. Ambient Conditions: Maintain ambient temperatures within range recommended by manufacturer, but not less than 70 deg F or more than 85 deg F, in spaces to receive resilient sheet flooring during the following time periods:
 - 1. 48 hours before installation.
 - 2. During installation.
 - 3. 48 hours after installation.
- B. After installation and until Substantial Completion, maintain ambient temperatures within range recommended by manufacturer, but not less than 55 deg F or more than 95 deg F.
- C. Close spaces to traffic during and for 48 hours after resilient sheet flooring installation.
- D. Install resilient sheet flooring after other finishing operations, including painting, have been completed.

**NISQUALLY STATE PARK
NEW FULL SERVICE PARK – PHASE 2**

1.9 WARRANTY

- A. Special Warranty for Resilient Flooring: Manufacturer agrees to repair or replace components of resilient sheet flooring installation that fail in materials or workmanship within specified warranty period.
 - 1. Warranty does not include deterioration or failure of resilient sheet flooring due to unusual traffic, failure of substrate, vandalism, or abuse.
 - 2. Warranty Period: 10 years from date of Substantial Completion.

PART 2 - PRODUCTS

2.1 PERFORMANCE CRITERIA

- A. Fire-Test-Response Characteristics: For resilient sheet flooring, as determined by testing identical products according to ASTM E648 or NFPA 253 by a qualified testing agency.
 - 1. Critical Radiant Flux Classification: Class I, not less than 0.45 W/sq. cm.
- B. Surface Coefficient of Friction: Provide products that meet the following requirements when tested in accordance with ASTM D2047.
 - 1. Flat Surfaces: 0.6.
 - 2. Inclined Surfaces: 0.8.
 - 3. Wet Surfaces: 0.88
 - 4. Dry Surfaces: 0.92.
- C. Accessibility Requirements: Comply with applicable provisions in U.S. Architectural & Transportation Barriers Compliance Board's "Americans with Disabilities Act (ADA), Accessibility Guidelines (ADAAG)" and ICC A117.1.

2.2 SLIP-RESISTANT VINYL SHEET FLOORING WITH BACKING

- A. Slip-Resistant Vinyl Sheet Flooring (NSV1): Sheet flooring composed of silicon carbide, aluminum trioxide, and colored quartz aggregate throughout its entire thickness.
 - 1. Products: Subject to compliance with requirements, provide products specified in Interior Floor Finish Schedule on Drawings or approved substitution.
 - 2. Performance Criteria:
 - a. Product Standard: ASTM F1303; Type I, Grade 1, Class A, safety flooring.
 - b. Chemical Resistance: ASTM F925; tested resistance.
 - c. Flexibility: ASTM F137; passes.
 - d. Light Reflectance Value (LRV): 10.

**NISQUALLY STATE PARK
NEW FULL SERVICE PARK – PHASE 2**

3. Product Standard: ASTM F1303.
 - a. Wearing Surface: Slip-resistant.
 - b. Wear-Layer: Homogenous.
 - c. Overall Thickness: 2.5 mm.
 - d. Interlayer Material: None.
 - e. Sheet Size: Nominally 6.7 ft. wide by 65.5 ft. long.
 - f. Seamless-Installation Method: Heat welded.
 - g. Backing: Non-woven polyester/cellulose, glass fiber reinforcement.
4. Wearing Surface: Textured.

2.3 VINYL SHEET FLOORING

A. Vinyl Sheet Flooring (VSF1):

1. Products: Subject to compliance with requirements, provide products specified in Interior Floor Finish Schedule on Drawings or approved substitution.
2. Product Standard: ASTM F1303.
 - a. Type (Binder Content): Type I, minimum binder content of 90 percent.
 - b. Wear-Layer Thickness: Grade 1, not less than 0.022 inch.
 - c. Overall Thickness: As standard with manufacturer, but not less than 0.080 inch.
 - d. Sheet Width: As standard with manufacturer.
 - e. Wearing Surface: Smooth unless indicated otherwise.
 - f. Backing: As standard with manufacturer.
 - g. Interlayer Material: Glass-fiber reinforced.
 - h. Seamless-Installation Method: Heat welded.
 - i. Colors and Patterns: As selected by Architect from full range.

2.4 INSTALLATION MATERIALS

- A. Trowelable Leveling and Patching Compounds: Latex-modified, portland cement based or blended hydraulic-cement-based formulation provided or approved by manufacturer for applications indicated.
 1. Ensure compatibility of patching compound with resilient flooring and related adhesives, per manufacturer's installation guidelines.
- B. Adhesives: Water-resistant type recommended by flooring and adhesive manufacturers to suit resilient sheet flooring and substrate conditions indicated with VOC content of 60 g/L or less.
- C. Seamless-Installation Accessories:
 1. Heat-Welding Bead: Manufacturer's solid-strand product for heat welding seams.
 - a. Colors: Match flooring.

**NISQUALLY STATE PARK
NEW FULL SERVICE PARK – PHASE 2**

PART 3 - EXECUTION

3.1 PREPARATION

- A. Prepare substrates per resilient sheet flooring manufacturer's written instructions to ensure adhesion of resilient sheet flooring.
- B. Concrete Substrates: Prepare according to ASTM F710.
 - 1. Verify that substrates are dry and free of curing compounds, sealers, and hardeners.
 - 2. Remove substrate coatings and other substances that are incompatible with flooring adhesives and that contain soap, wax, oil, or silicone, using mechanical methods recommended by resilient sheet flooring manufacturer. Do not use solvents.
 - 3. Moisture Testing: Perform tests so that each test area does not exceed 1,000 sq. ft., and perform no fewer than 3 tests in each installation area and with test areas evenly spaced in installation areas.
 - a. Relative Humidity Test: Using in-situ probes, ASTM F2170. Proceed with installation only after substrates have a maximum 90 percent relative humidity level measurement.
- C. Fill cracks, holes, and depressions in substrates with trowelable leveling and patching compound and remove bumps and ridges to produce a uniform and smooth substrate.
- D. Do not install resilient sheet flooring until they are same temperature as space where they are to be installed. Move resilient sheet flooring and installation materials into spaces where they will be installed at least 48 hours in advance of installation.
- E. Immediately before installation, sweep and vacuum clean substrates to be covered by resilient sheet flooring.

3.2 INSTALLATION OF RESILIENT SHEET FLOORING

- A. Comply with manufacturer's written instructions for installing resilient sheet flooring.
- B. Unroll resilient sheet flooring and allow them to stabilize before cutting and fitting.
- C. Lay out resilient sheet flooring as follows:
 - 1. Maintain uniformity of floor covering direction.
 - 2. Minimize number of seams; place seams in inconspicuous and low-traffic areas, a minimum of 6 inches away from parallel joints in floor covering substrates.
 - 3. Match edges of resilient sheet flooring for color shading at seams.
 - 4. Avoid cross seams.
- D. Scribe and cut resilient sheet flooring to butt neatly and tightly to vertical surfaces, permanent fixtures, and built-in furniture including cabinets, pipes, outlets, and door frames.
- E. Extend resilient sheet flooring into toe spaces, door reveals, closets, and similar openings.

**NISQUALLY STATE PARK
NEW FULL SERVICE PARK – PHASE 2**

- F. Maintain reference markers, holes, or openings that are in place or marked for future cutting by repeating on resilient sheet flooring as marked on substrates. Use chalk or other nonpermanent marking device.
- G. Install resilient sheet flooring on covers for telephone and electrical ducts and similar items in installation areas. Maintain overall continuity of color and pattern between pieces of resilient sheet flooring installed on covers and adjoining floor covering. Tightly adhere floor covering edges to substrates that abut covers and to cover perimeters.
- H. Adhere resilient sheet flooring to substrates using a full spread of adhesive applied to substrate to produce a completed installation without open cracks, voids, raising and puckering at joints, telegraphing of adhesive spreader marks, and other surface imperfections.
- I. Seamless Installation: Use the following method unless indicated otherwise.
 - 1. Heat-Welded Seams: Comply with ASTM F1516. Rout joints and use welding bead to permanently fuse sections into a seamless floor covering. Prepare, weld, and finish seams to produce surfaces flush with adjoining floor covering surfaces.

3.3 CLEANING

- A. Comply with manufacturer's written instructions for cleaning and protection of resilient sheet flooring.
- B. Perform the following operations immediately after completing resilient sheet flooring installation:
 - 1. Remove adhesive and other blemishes from surfaces.
 - 2. Sweep and vacuum surfaces thoroughly.
 - 3. Damp-mop surfaces to remove marks and soil.
- C. Floor Polish: Remove soil, visible adhesive, and surface blemishes from floor covering before applying liquid floor polish.
 - 1. Apply 2 coats or as many as recommended by flooring manufacturer.

3.4 PROTECTION

- A. Protect resilient sheet flooring products from mars, marks, indentations, and other damage from construction operations and placement of equipment and fixtures until Substantial Completion.
 - 1. Use protection methods recommended in writing by manufacturer.
 - 2. Do not move heavy and sharp objects directly over flooring. Protect flooring with plywood or hardboard panels to prevent damage from storing or moving objects over flooring.

END OF SECTION

**NISQUALLY STATE PARK
NEW FULL SERVICE PARK – PHASE 2**

SECTION 096813 – TILE CARPETING

PART 1 - GENERAL

1.1 SUMMARY

A. Section Includes:

1. Modular carpet tile.

1.2 ADMINISTRATIVE REQUIREMENTS

A. Preinstallation Meeting: Conduct meeting at Project site.

1. Review methods and procedures related to carpet tile installation including the following:
 - a. Review delivery, storage, and handling procedures.
 - b. Review ambient conditions and ventilation procedures.
 - c. Review subfloor preparation procedures.

1.3 ACTION SUBMITTALS

A. Product Data: For each type of product.

1. Include manufacturer's written data on physical characteristics, durability, and fade resistance.
2. Include manufacturer's written installation recommendations for each type of substrate.

B. Shop Drawings: For carpet tile installation, plans showing the following:

1. Columns, doorways, enclosing walls or partitions, built-in cabinets, and locations where cutouts are required in carpet tiles.
2. Carpet tile type, color, and dye lot.
3. Type of subfloor.
4. Type of installation.
5. Pattern of installation.
6. Pattern type, location, and direction.
7. Pile direction.
8. Type, color, and location of insets and borders.
9. Type, color, and location of edge, transition, and other accessory strips.
10. Transition details to other flooring materials.

C. Samples for Verification: For each of the following products and for each color and texture required. Label each Sample with manufacturer's name, material description, color, pattern, and designation indicated on Drawings and in schedules.

1. Carpet Tile: Full-size Sample.
2. Exposed Edge, Transition, and Other Accessory Stripping: 12 inch long Samples.

**NISQUALLY STATE PARK
NEW FULL SERVICE PARK – PHASE 2**

1.4 INFORMATIONAL SUBMITTALS

- A. Qualification Data: For Installer.
- B. Product Test Reports: For carpet tile, for tests performed by a qualified testing agency.

1.5 CLOSEOUT SUBMITTALS

- A. Maintenance Data: For carpet tiles to include in maintenance manuals. Include the following:
 - 1. Methods for maintaining carpet tile, including cleaning and stain-removal products and procedures and manufacturer's recommended maintenance schedule.
 - 2. Precautions for cleaning materials and methods that could be detrimental to carpet tile.

1.6 MAINTENANCE MATERIAL SUBMITTALS

- A. Furnish extra materials, from same product run, that match products installed and that are packaged with protective covering for storage and identified with labels describing contents.
 - 1. Carpet Tile: Full-size units equal to 5 percent of amount installed for each type indicated, but not less than 2 complete cartons.

1.7 QUALITY ASSURANCE

- A. Installer Qualifications: An experienced installer with a minimum of 3 years of experience, who is certified by the International Certified Floorcovering Installers Association at Commercial II certification level.

1.8 DELIVERY, STORAGE, AND HANDLING

- A. Comply with CRI's "CRI Carpet Installation Standard."

1.9 FIELD CONDITIONS

- A. Comply with CRI's "CRI Carpet Installation Standard" for temperature, humidity, and ventilation limitations.
- B. Environmental Limitations: Do not deliver or install carpet tiles until spaces are enclosed and weathertight, wet-Work in spaces is complete and dry, and ambient temperature and humidity conditions are maintained at levels planned for building occupants during remainder of construction period.
- C. Do not install carpet tiles over concrete slabs until slabs have cured and are sufficiently dry to bond with adhesive and concrete slabs have pH range recommended by carpet tile manufacturer.
- D. Where items are indicated for installation on top of carpet tiles, install carpet tiles before installing these items.

**NISQUALLY STATE PARK
NEW FULL SERVICE PARK – PHASE 2**

1.10 WARRANTY

- A. Special Warranty for Carpet Tiles: Manufacturer agrees to repair or replace components of carpet tile installation that fail in materials or workmanship within specified warranty period.
 - 1. Warranty does not include deterioration or failure of carpet tile due to unusual traffic, failure of substrate, vandalism, or abuse.
 - 2. Warranty Period: Limited lifetime from date of Substantial Completion.

PART 2 - PRODUCTS

2.1 REGULATORY REQUIREMENTS

- A. Accessibility Standard: Comply with applicable provisions in DOJ's "2010 ADA Standards for Accessible Design" and ICC A117.1.

2.2 CARPET TILE

- A. Modular Carpet Tile (CPT1):

- 1. Products: Subject to compliance with requirements, provide products specified in Interior Floor Finish Schedule on Drawings or approved substitution.
- 2. Product Standard: ASTM F1303.

- B. Material: Provide carpet tile that meets the minimum following requirements:

- 1. Construction: Multi-level pattern loop.
- 2. Fiber: EcoSolution Q Nylon or other nylon 6, 6 fiber.
- 3. Dye Method: 100 percent solution dyed.
- 4. Primary Backing: Synthetic.
- 5. Secondary Backing: EcoWorx Tile or other PVC-free backing.
- 6. Finished Pile Thickness: 0.098 inch.
- 7. Total Thickness: 0.244 inch.
- 8. Stitches: 10.0 per inch.
- 9. Gage: 1/12 inch.
- 10. Tufted Weight: 18 oz./cu. yd tile.
- 11. Density: 6,612 oz./cu. yd.
- 12. Size: As indicated on Drawings.
- 13. Applied Treatments:

- a. Applied Soil-Resistance Treatment: Manufacturer's standard material.
- b. Antimicrobial Treatment: Manufacturer's standard material.

- 1) Antimicrobial Activity: Not less than 2-mm halo of inhibition for gram-positive bacteria, not less than 1-mm halo of inhibition for gram-negative bacteria, and no fungal growth, according to AATCC 174.

**NISQUALLY STATE PARK
NEW FULL SERVICE PARK – PHASE 2**

C. Performance Criteria:

1. Electrostatic Propensity: Less than 3.5 kV according to AATCC 134.
2. Critical Radiant Flux Classification: Not less than 0.22 W/sq. cm according to NFPA 253.

2.3 ACCESSORIES

- A. Trowelable Leveling and Patching Compounds: Latex-modified, hydraulic-cement-based formulation provided or recommended by carpet tile manufacturer.
- B. Adhesive Tape: Water-resistant type, compatible with flooring, recommended by manufacturer to suit carpet and substrate conditions indicated, complying with the following moisture resistant properties:
1. Basis-of-Design Product: Subject to compliance with requirements, provide the following:
 - a. Shaw Contract Group; a Berkshire Hathaway company: LokDots.
 - b. Approved substitution.
 2. Composition: Compounded acrylic adhesive, applied to PET polyester backing with PET polyester release liner.
 3. Solids: Greater than 99 percent.
 4. Size: 3 inch by 3 inch.
 5. Suitable for use over new concrete substrates with in-situ moisture measurements of up to 80 percent RH as measured by ASTM F2170 or moisture vapor emission rate (MVER) of up to 3 pounds per ASTM F1869, and a pH of 10.
- C. Metal Edge/Transition Strips: Extruded aluminum with mill finish of profile and width shown, of height required to protect exposed edge of carpet, and of maximum lengths to minimize running joints.
- D. Resilient Transition Strips: Specified in Section 096513 – Resilient Base and Accessories.

PART 3 - EXECUTION

3.1 EXAMINATION

- A. Examine substrates, areas, and conditions, with Installer present, for compliance with requirements for maximum moisture content, alkalinity range, installation tolerances, and other conditions affecting carpet tile performance.
- B. Examine carpet tile for type, color, pattern, and potential defects.
- C. Concrete Slabs: Verify that finishes comply with requirements specified in Section 033000 – Cast-in-Place Concrete and that surfaces are free of cracks, ridges, depressions, scale, and foreign deposits.
1. Moisture Testing: Perform tests so that each test area does not exceed 200 sq. ft., and perform no fewer than 3 tests in each installation area and with test areas evenly spaced in installation areas.

**NISQUALLY STATE PARK
NEW FULL SERVICE PARK – PHASE 2**

- a. Anhydrous Calcium Chloride Test: ASTM F1869. Proceed with installation only after substrates have maximum moisture-vapor-emission rate of 3 lb of water/1,000 sq. ft. in 24 hours.
 - b. Relative Humidity Test: Using in situ probes, ASTM F2170. Proceed with installation only after substrates have a maximum 75 percent relative humidity level measurement.
 - c. Perform additional moisture tests recommended in writing by adhesive and carpet tile manufacturers. Proceed with installation only after substrates pass testing.
- D. Proceed with installation only after unsatisfactory conditions have been corrected.

3.2 PREPARATION

- A. Comply with the Carpet and Rug Institute's CRI 104 and with carpet tile manufacturer's written installation instructions for preparing substrates indicated to receive carpet tile.
- B. Use trowelable leveling and patching compounds, according to manufacturer's written instructions, to fill cracks, holes, depressions, and protrusions in substrates. Fill or level cracks, holes and depressions 1/8 inch wide or wider, and protrusions more than 1/32 inch unless more stringent requirements are required by manufacturer's written instructions.
- C. Concrete Substrates: Remove coatings, including curing compounds, and other substances that are incompatible with adhesives and that contain soap, wax, oil, or silicone, without using solvents. Use mechanical methods recommended in writing by adhesive and carpet tile manufacturers.
- D. Broom and vacuum clean substrates to be covered immediately before installing carpet tile.

3.3 INSTALLATION OF TILE CARPETING

- A. Comply with Carpet and Rug Institute's CRI 104, Section 10, "Carpet Tile," and with carpet tile manufacturer's written installation instructions.
- B. Installation Method: Manufacturer's recommended self-adhesive tape dots.
- C. Maintain dye-lot integrity. Do not mix dye lots in same area.
- D. Maintain pile-direction patterns recommended in writing by carpet tile manufacturer.
- E. Cut and fit carpet tile to butt tightly to vertical surfaces, permanent fixtures, and built-in furniture including cabinets, pipes, outlets, edgings, thresholds, and nosings. Bind or seal cut edges as recommended by carpet tile manufacturer.
- F. Extend carpet tile into toe spaces, door reveals, closets, open-bottomed obstructions, removable flanges, alcoves, and similar openings.
- G. Maintain reference markers, holes, and openings that are in place or marked for future cutting by repeating on carpet tile as marked on subfloor. Use nonpermanent, nonstaining marking device.
- H. Install pattern parallel to walls and borders.

**NISQUALLY STATE PARK
NEW FULL SERVICE PARK – PHASE 2**

- I. Access Flooring: Stagger joints of carpet tiles so carpet tile grid is offset from access flooring panel grid. Do not fill seams of access flooring panels with carpet adhesive; keep seams free of adhesive.

3.4 CLEANING

- A. Perform the following operations immediately after installing carpet tile:
 - 1. Remove excess adhesive and other surface blemishes using cleaner recommended by carpet tile manufacturer.
 - 2. Remove yarns that protrude from carpet tile surface.
 - 3. Vacuum carpet tile using commercial machine with face-beater element.

3.5 PROTECTION

- A. Protect installed carpet tile to comply with the Carpet and Rug Institute's CRI 104, Section 13.7.
- B. Protect carpet tile against damage from construction operations and placement of equipment and fixtures during remainder of construction period. Use protection methods indicated or recommended in writing by carpet tile manufacturer.

END OF SECTION

**NISQUALLY STATE PARK
NEW FULL SERVICE PARK – PHASE 2**

SECTION 097413 – WOOD WALL COVERING

PART 1 - GENERAL

1.1 SUMMARY

A. Section Includes:

1. Thermally-modified, linear wood planks.

1.2 ADMINISTRATIVE REQUIREMENTS

- A. Preinstallation Meeting: Conduct conference at Project site.

1.3 ACTION SUBMITTALS

A. Samples for Verification:

1. For wood linear planks, one 12 inch piece.

1.4 INFORMATIONAL SUBMITTALS

- A. Qualification Data: For Installer.

1.5 CLOSEOUT SUBMITTALS

- A. Maintenance Data: Include related accessories, to include in maintenance manuals
- B. Manufacturer's maintenance instructions that include recommendations for periodic cleaning and maintenance of material.

1.6 QUALITY ASSURANCE

A. Mockups:

1. Build mockups of typical wall linear plank assembly as designated by Architect.
2. Do not proceed with remaining wall linear plank assembly Work until approved by Architect.
3. Subject to compliance with requirements, approved mockups may become part of completed Work if undisturbed at time of Substantial Completion.

**NISQUALLY STATE PARK
NEW FULL SERVICE PARK – PHASE 2**

1.7 DELIVERY, STORAGE, AND HANDLING

- A. Deliver and store products in manufacturer's packaging bearing brand name and manufacturer's identification until ready for installation.
- B. Handle materials to avoid damage.
- C. Protect wood wall covering products during transit, delivery, storage, and handling to prevent damage, soiling, and deterioration.
 - 1. Store wood wall plank products indoors until installation.
 - a. Do not allow materials to get wet.

1.8 FIELD CONDITIONS

- A. Environmental Limitations: Do not deliver or install wood linear plank materials until temperature and relative humidity are within limits recommended by manufacturer.
 - 1. Do not install products when environmental conditions are unacceptable to manufacturer.

1.9 WARRANTY

- A. Manufacturer's Warranty for Thermally Modified Wood: Manufacturer agrees to repair or replace trim that fails due to defects in manufacturing within specified warranty period. Failures include deterioration, delamination, and excessive swelling from moisture.
 - 1. Warranty Period: 15 years from date of Substantial Completion.

PART 2 - PRODUCTS

2.1 THERMALLY-MODIFIED, LINEAR WOOD PLANKS

- A. Thermally-Modified, Linear Wood Planks: Dimensionally-stable natural wood made resistant to water, decay, and insects through a controlled thermal modification process.
 - 1. Basis-of-Design Product: Subject to compliance with requirements, provide the following:
 - a. Lunawood Corporation: ThermoWood Luna Triple 32x140.
 - b. Approved substitution from one of the following:
 - 1) Americana by Bingaman.
 - 2) Arbor Wood Co.
 - 3) Northern Forest Products.
 - 4) Siparila Oy.
 - 5) Thermory USA.

**NISQUALLY STATE PARK
NEW FULL SERVICE PARK – PHASE 2**

2. Class: LunaThermo-D.
3. Surface: Planed.
4. Wood Species: Nordic Spruce.
5. Finish: Natural.
6. Design: Grooved batten look.
7. Construction: Solid planks routed to produce batten look.
8. Plank Size: Nominal 5-1/2 inches by random 12 to 18 foot lengths
9. Panel Thickness: Nominal 1-1/4 inch.
10. Edges: Tongue and groove.
11. Ends: Square.
12. Surface Texture: Smooth.

2.2 MISCELLANEOUS MATERIALS

- A. Fasteners: Provide fasteners of size and type that comply with wood plank manufacturer's requirements. Provide nails or screws, in sufficient length, to penetrate not less than 1-1/2 inches into wood substrate.
 1. Use stainless steel unless otherwise indicated.
- B. Nails: ASTM F1667.
- C. Sealants: SLNT-AL1 as specified in Section 079200 – Joint Sealants.

PART 3 - EXECUTION

3.1 EXAMINATION

- A. Examine substrates, with Installer present, for compliance with requirements for installation tolerances and other conditions affecting performance of installed wood linear planks.
- B. Examine materials before installation. Reject materials that are wet, moisture damaged, and mold damaged.
- C. Proceed with installation only after unsatisfactory conditions have been corrected.

3.2 PREPARATION

- A. Protect surrounding Work from damage or disfiguration.
- B. Vacuum clean existing surfaces and damp clean.
- C. Clean substrates of projections and substances detrimental to application.
- D. Prepare surfaces using methods recommended by manufacturer for achieving best result for substrate under Project conditions.

**NISQUALLY STATE PARK
NEW FULL SERVICE PARK – PHASE 2**

- E. Condition wood material to average prevailing humidity conditions in installation areas prior to installing.

3.3 INSTALLATION, GENERAL

- A. Do not use materials that are unsound, warped, improperly treated or finished, inadequately seasoned, or too small to fabricate with proper jointing arrangements.
 - 1. Do not use materials with defective surfaces, sizes, or patterns.
- B. Install materials level, plumb, true, and aligned with adjacent materials.
 - 1. Use concealed shims where necessary for alignment.
 - 2. Scribe and cut siding materials to fit adjoining Work.
 - 3. Install to tolerance of 1/8 inch in 96 inches for level and plumb. Install adjoining siding materials with 1/32 inch maximum offset for flush installation and 1/16 inch maximum offset for reveal installation.
 - 4. Coordinate materials with materials and systems in or adjacent to it.
 - 5. Provide cutouts for mechanical and electrical items that penetrate materials.

3.4 INSTALLATION OF LINEAR WOOD PLANKS

- A. Install linear wood planks to comply with manufacturer's written instructions and warranty requirements.
 - 1. Secure with countersunk, concealed fasteners and blind nailing.
 - 2. Use fine finishing nails for exposed fastening, countersunk and flush with plank surface.
 - 3. Use filler matching finish of items being installed.
 - 4. Leave 1/8 inch gap at trim and corners, unless otherwise recommended by manufacturer.
 - 5. Butt joints only over framing or blocking, nailing top and bottom on each side and staggering joints in subsequent courses.

3.5 ADJUSTING

- A. Replace wood wall linear plank materials that are damaged or do not comply with requirements.
 - 1. Wood wall linear plank materials may be repaired or refinished if Work complies with requirements and shows no evidence of repair or refinishing.
- B. Adjust joinery for uniform appearance.

3.6 CLEANING

- A. Clean wood wall linear plank materials on exposed and semiexposed surfaces.
- B. Touch up field-applied finishes to restore damaged or soiled areas.

**NISQUALLY STATE PARK
NEW FULL SERVICE PARK – PHASE 2**

3.7 PROTECTION

- A. Protect installed wood wall linear plank materials from damage from construction operation until Substantial Completion.
- B. Remove and replace wood wall linear plank materials that are wet, moisture damaged, and mold damaged.
 - 1. Indications that materials are wet or moisture damaged include discoloration, sagging, or irregular shape.
 - 2. Indications that materials are mold damaged include fuzzy or splotchy surface contamination and discoloration.

END OF SECTION

**NISQUALLY STATE PARK
NEW FULL SERVICE PARK – PHASE 2**

SECTION 098100 – ACOUSTICAL INSULATION

PART 1 - GENERAL

1.1 SUMMARY

A. Section Includes:

1. Sound-attenuation insulation.

1.2 ADMINISTRATIVE REQUIREMENTS

A. Coordination:

1. Coordinate with related Work for sequencing installation of sound-attenuation insulation.
2. Avoid unnecessary exposure of acoustical material to abrasion and other damage likely to occur during construction operations subsequent to its application.
3. Do not apply acoustical material to metal deck substrates until concrete topping, if any, has been completed.
 - a. For metal roof decks without concrete topping, do not apply acoustical material to metal roof deck substrates until roofing has been completed.
 - b. Prohibit roof traffic during application and drying of acoustical material.
4. Do not install enclosing or concealing construction until after acoustical material has been applied and inspected and corrections have been made to defective applications.

B. Preinstallation Meetings: Conduct at Project site to review the following for spray-applied acoustic insulation system:

1. Finalize construction schedule and verify sequencing and coordination requirements.

1.3 ACTION SUBMITTALS

A. Product Data: For each type of product.

1.4 INFORMATIONAL SUBMITTALS

A. Test and Evaluation Reports:

1. Product Test Reports: For each product, for tests performed by qualified testing agency.

B. Qualification Statements: For Installer.

**NISQUALLY STATE PARK
NEW FULL SERVICE PARK – PHASE 2**

1.5 DELIVERY, STORAGE, AND HANDLING

- A. Protect insulation materials from physical damage and from deterioration due to moisture, soiling, and other sources.
 - 1. Store inside and in a dry location.
 - 2. Comply with manufacturer's written instructions for handling, storing, and protecting during installation.

PART 2 - PRODUCTS

2.1 MANUFACTURERS

- A. Source Limitations: Obtain each type of sound attenuation insulation from single source from single manufacturer.

2.2 PERFORMANCE CRITERIA

- A. Fire-Test-Response Characteristics: Units shall comply with "Surface-Burning Characteristics" or "Fire Growth Contribution" Subparagraph below, or both, as determined by testing identical products by UL or another testing and inspecting agency acceptable to authorities having jurisdiction:
 - 1. Surface-Burning Characteristics: Comply with ASTM E84 or UL 723; testing by a qualified testing agency. Identify products with appropriate markings of applicable testing agency.
 - a. Flame-Spread Index: 5 or less.
 - b. Smoke-Developed Index: 35 or less.

2.3 SOUND ATTENUATION INSULATION

- A. Sound Attenuation Blankets: ASTM C665, Type I (blankets without membrane facing) produced by combining thermosetting resins with mineral fibers manufactured from glass, slag wool, or rock wool.
 - 1. Products: Subject to compliance with requirements, provide one of the following:
 - a. CertainTeed, Saint-Gobain: CertaPRO AcoustaTherm Batts.
 - b. Johns Manville: Formaldehyde-Free Unfaced Batts.
 - c. Knauf Insulation: EcoBatt Insulation with ECOSE Technology.
 - d. Owens Corning: PINK Next Gen Fiberglas Sound Attenuation Batts (SAB).
 - e. Rockwool International: Acoustical Fire Batts (AFB) evo.
 - f. Thermafiber, Inc. (an Owens Corning company): Thermafiber SAFB FF.
 - g. Approved substitution.
 - 2. Fire-Resistance-Rated Assemblies: Comply with mineral-fiber requirements of assembly.

**NISQUALLY STATE PARK
NEW FULL SERVICE PARK – PHASE 2**

3. Surface-Burning Characteristics: Comply with ASTM E84; testing by qualified testing agency
 - a. Flame-Spread Index: 25 or less.
 - b. Smoke-Developed Index: 50 or less.
4. Applications:
 - a. Concealed wall conditions where indicated.

PART 3 - EXECUTION

3.1 EXAMINATION

- A. Verify that substrates are not obstructed by ducts, piping, equipment, and other suspended construction that will interfere with application of spray-applied acoustic insulation material.
- B. Verify that substrates are free of dirt, oil, grease, release agents, rolling compounds, mill scale, loose scale, incompatible primers, incompatible paints, incompatible encapsulants, or other foreign substances capable of impairing bond of acoustical materials with substrates under conditions of normal use or exposure.
- C. Verify that objects penetrating acoustical material, including clips, hangers, support sleeves, conduits and similar items, are securely attached to substrates.
- D. Verify that substrates are not obstructed by ducts, piping, equipment, and other suspended construction that will interfere with application of spray-applied acoustic insulation material.
- E. Proceed with installation only after unsatisfactory conditions have been corrected.

3.2 INSTALLATION, GENERAL

- A. Comply with insulation manufacturer's written instructions applicable to products and applications.
- B. Install insulation that is undamaged, dry, and unsoiled and that has not been left exposed to ice, rain, or snow at any time.
- C. Extend insulation to envelop entire area to be insulated. Fit tightly around obstructions and fill voids with insulation. Remove projections that interfere with placement.
- D. Provide sizes to fit applications and selected from manufacturer's standard thicknesses, widths, and lengths. Apply single layer of insulation units unless multiple layers are otherwise shown or required to make up total thickness or to achieve R-value.

**NISQUALLY STATE PARK
NEW FULL SERVICE PARK – PHASE 2**

3.3 INSTALLATION OF SOUND ATTENUATION INSULATION

- A. Sound Attenuation Insulation: Install in cavities formed by framing members according to the following requirements:
 - 1. Use insulation widths and lengths that fill the cavities formed by framing members. If more than 1 length is required to fill cavities, provide lengths that will produce a snug fit between ends.
 - 2. Place insulation in cavities formed by framing members to produce a friction fit between edges of insulation and adjoining framing members.
 - 3. Maintain 3 inch clearance of insulation around recessed lighting fixtures not rated for or protected from contact with insulation.
 - 4. For wood-framed construction, install blankets according to ASTM C1320.

3.4 ADJUSTING

- A. Adjust sags or twists that develop in ceiling systems and replace materials which are damaged or faulty.

3.5 CLEANING

- A. After Completion of Installation: Clean soiled surfaces.
 - 1. Remove severely damaged material, discolored material, and moderately damaged material that cannot be properly touch-up finished and replace with new material.

3.6 PROTECTION

- A. Protect installed insulation from damage due to harmful weather exposures, physical abuse, construction activities, or other causes to ensure spray-applied acoustic insulation is without damage or deterioration at time of Substantial Completion.

END OF SECTION

**NISQUALLY STATE PARK
NEW FULL SERVICE PARK – PHASE 2**

SECTION 098431 – SOUND-ABSORBING WALL AND CEILING UNITS

PART 1 - GENERAL

1.1 SUMMARY

A. Section Includes:

1. Shop-fabricated, acoustical panel units tested for acoustical performance, including the following:
 - a. Sound-absorbing wall panels.
 - b. Sound-absorbing ceiling panels.

1.2 ADMINISTRATIVE REQUIREMENTS

- A. Preinstallation Meetings: Conduct meeting at Project site.

1.3 ACTION SUBMITTALS

- A. Product Data: For each type of product.

1. Include panel edge, core material, and mounting indicated.

- B. Shop Drawings: For unit assembly and installation. Include the following:

1. Plans, elevations, sections, and mounting devices and details.
 - a. Include reflected ceilings plans that pertain to Work of this Section.
2. Details at panel head, base, joints, and corners.
3. Details of intersections at ceiling, floor base, and walls.
 - a. Indicate panel edge profile and core materials.
4. Details at cutouts and penetrations for other Work.

- C. Samples for Verification: For the following products:

1. Panel Edge: 12 in. long showing each edge profile, corner, and finish.
2. Core Material: 12 sq. in. at corner.
3. Mounting Devices: Full-size.
4. Assembled Panels: Approximately 36 by 36 inches, including joints and mounting methods.

**NISQUALLY STATE PARK
NEW FULL SERVICE PARK – PHASE 2**

1.4 INFORMATIONAL SUBMITTALS

- A. Product Certificates: For each type of unit.
- B. Sample Warranty: F or manufacturer's special warranty.

1.5 CLOSEOUT SUBMITTALS

- A. Maintenance Data: For each type of unit to include in maintenance manuals.

1.6 MAINTENANCE MATERIAL SUBMITTALS

- A. Furnish extra materials, from same product run, that match products installed and that are packaged with protective covering for storage and identified with labels describing contents.
 - 1. Mounting Devices: Full-size units equal to 5 percent of amount installed, but no fewer than 5 devices.

1.7 QUALITY ASSURANCE

- A. Field Samples:
 - 1. Size: Minimum 48 inches wide by full panel length for each type, color, and pattern in locations directed by Architect.
 - a. Include intersection of wall and ceiling, corners, and perimeters.
 - 2. Approval of field samples does not constitute approval of deviations from Contract Documents contained in field samples unless Architect specifically approves such deviations in writing.
 - 3. Subject to compliance with requirements, approved field samples may become part of completed Work if undisturbed at time of Substantial Completion.

1.8 DELIVERY, STORAGE, AND HANDLING

- A. Comply with unit manufacturers' written instructions for minimum and maximum temperature and humidity requirements for shipment, storage, and handling.
- B. Deliver materials and units to Project site in original, unopened packages and store them in a fully-enclosed space protected against damage from moisture, direct sunlight, surface contamination, and other causes.
- C. Provide labels indicating brand name, style, size, and thickness.
- D. Handle sound-absorptive panels carefully to avoid chipping edges or damaging units.

**NISQUALLY STATE PARK
NEW FULL SERVICE PARK – PHASE 2**

1.9 FIELD CONDITIONS

- A. Environmental Limitations: Do not install units until spaces are enclosed and weathertight, wet-Work in spaces is complete and dry, Work at and above ceilings is complete, and ambient temperature and humidity conditions are maintained at levels indicated for Project when occupied for its intended use.
- B. Lighting: Do not install units until a permanent level of lighting is provided on surfaces to receive the units.
- C. Air-Quality Limitations: Protect units from exposure to airborne odors, such as tobacco smoke, and install units under conditions free from odor contamination of ambient air.
- D. Field Measurements: Verify unit locations and actual dimensions of openings and penetrations by field measurements before fabrication, and indicate them on Shop Drawings.

1.10 WARRANTY

- A. Special Warranty: Manufacturer agrees to repair or replace units and components that fail in materials or workmanship within specified warranty period.
 - 1. Failures include the following:
 - a. Acoustical performance.
 - b. Fabric sagging, distorting, or releasing from panel edge.
 - c. Warping of core.
 - 2. Warranty Period: 3 years from date of Substantial Completion.

PART 2 - PRODUCTS

2.1 MANUFACTURERS

- A. Source Limitations: Obtain wall and ceiling units from single source from single manufacturer.

2.2 PERFORMANCE CRITERIA

- A. Fire-Test-Response Characteristics: Units shall comply with "Surface-Burning Characteristics" or "Fire Growth Contribution" Subparagraph below, or both, as determined by testing identical products by UL or another testing and inspecting agency acceptable to authorities having jurisdiction:
 - 1. Surface-Burning Characteristics: Comply with ASTM E84 or UL 723; testing by a qualified testing agency. Identify products with appropriate markings of applicable testing agency.
 - a. Flame-Spread Index: 25 or less.
 - b. Smoke-Developed Index: 450 or less.

**NISQUALLY STATE PARK
NEW FULL SERVICE PARK – PHASE 2**

2. Fire Growth Contribution: Comply with acceptance criteria of local code and authorities having jurisdiction when tested according to NFPA 265 Method B Protocol or NFPA 286.

2.3 SOUND-ABSORBING WALL UNITS

A. Products: See Interior Finish Schedule on Drawings for selected ceiling panel products.

B. Sound-Absorbing Wall Panel: Manufacturer's standard panel construction.

1. Product: Subject to compliance with requirements, provide one of the following:
 - a. Acoustical Solutions: PolyPhon Polyester Acoustical Panels.
 - b. Acoustical Surfaces, Inc.: Poly Max Wall Panels.
 - c. Autex Acoustic, LLC: Quietspace Panel.
 - d. FSorb: FSorb Acoustical Panels.
 - e. Kinetics Noise Control, Inc.: Kleen Panel.
 - f. Approved substitution.
2. Panel Shape: Flat.
3. Mounting: Back mounted with manufacturer's standard adhesive, secured to substrate.
4. Core: 100 percent recycled, non-woven, thermally-bonded polyester containing no chemical binders or retardants.
5. Density: Minimum 5 pcf.
6. Edge Profile: Manufacturer's standard square edge.
7. Corners: Square.
8. Acoustical Performance: Sound absorption NRC of 0.90 according to ASTM C423 for Type A mounting according to ASTM E795.
9. Nominal Core Thickness: 2 inches.
10. Panel Width: 48 inches unless indicated otherwise.
11. Panel Length: 96 inches unless indicated otherwise.

2.4 SOUND-ABSORBING CEILING UNITS

A. Products: See Interior Finish Schedule on Drawings for selected ceiling panel products.

B. Sound-Absorbing Ceiling Panel: Manufacturer's standard panel construction.

1. Product: Subject to compliance with requirements, provide one of the following:
 - a. Acoustical Solutions: PolyPhon Polyester Acoustical Panels.
 - b. Acoustical Surfaces, Inc.: Poly Max Ceiling Panels.
 - c. Autex Acoustic, LLC: Quietspace Panel.
 - d. FSorb: FSorb Acoustical Panels.
 - e. Kinetics Noise Control, Inc.: Kleen Panel.
 - f. Approved substitution.
2. Panel Shape: Flat.
3. Mounting: Back mounted with manufacturer's standard adhesive, secured to substrate.

**NISQUALLY STATE PARK
NEW FULL SERVICE PARK – PHASE 2**

4. Core: 100 percent recycled, non-woven, thermally-bonded polyester containing no chemical binders or retardants.
5. Density: Minimum 5 pcf.
6. Edge Profile: Manufacturer's standard square edge.
7. Corners: Square.
8. Acoustical Performance: Sound absorption NRC of 0.90 according to ASTM C423 for Type A mounting according to ASTM E795.
9. Nominal Core Thickness: 2 inches.
10. Panel Width: 48 inches unless indicated otherwise.
11. Panel Length: 96 inches unless indicated otherwise.

2.5 MATERIALS

A. Core Materials: Manufacturer's standard.

1. Fire-Retardant Formed Plastic: Manufacturer's standard formed plastic.
 - a. Surface Burning Characteristics: ASTM E84 or UL 723.
 - 1) Maximum Flame Spread: 25.
 - 2) Smoke Developed: 25.

B. Mounting Devices: Concealed on back of unit, recommended by manufacturer to support weight of unit, and as follows:

1. Acoustical Tile Adhesive: ASTM D1779 or ASTM C557; water-based acoustic tile adhesive, recommended in writing by acoustical panel manufacturer.
 - a. Surface-Burning Characteristics: ASTM E84; Class A.
 - b. Verify adhesives have a VOC content of 70 g/L or less.

2.6 FABRICATION

A. Standard Construction: Use manufacturer's standard construction unless indicated otherwise.

B. Dimensional Tolerances of Finished Units: Plus or minus 1/16 inch for the following:

1. Thickness.
2. Edge straightness.
3. Overall length and width.
4. Squareness from corner to corner.
5. Chords, radii, and diameters.

**NISQUALLY STATE PARK
NEW FULL SERVICE PARK – PHASE 2**

PART 3 - EXECUTION

3.1 EXAMINATION

- A. Examine fabricated units, substrates, areas, and conditions for compliance with requirements, installation tolerances, and other conditions affecting unit performance.
- B. Proceed with installation only after unsatisfactory conditions have been corrected.

3.2 INSTALLATION OF SOUND-ABSORBING WALL AND CEILING PANELS

- A. Install panels as follows and in locations indicated.
 - 1. Install panels with faces flush and scribed to fit adjoining Work accurately at borders and at penetrations.
 - 2. Install wall panels with vertical surfaces and edges plumb, top edges level and in alignment with other units.
 - 3. Install ceiling panels with edges in alignment with other ceiling panels or as indicated.
- B. Comply with manufacturer's written instructions for installation of units using type of mounting devices indicated.
- C. Adhesive Installation: Install acoustical panels by bonding to substrate using adhesive and procedure recommended in writing by acoustical panel manufacturer and as follows:
 - 1. Wipe and prime wall and ceiling surfaces.
 - 2. Remove loose dust from backs of acoustical panels by brushing.
 - 3. Apply adhesive to backs of acoustical panels in patterns, locations, and thickness as recommended by panel manufacturer.
 - 4. Align panels in locations indicated and apply medium pressure on each side of panel to set edge adhesive, then apply even pressure to remaining panel areas.

3.3 INSTALLATION TOLERANCES

- A. Variation from Plumb and Level: Plus or minus 1/16 inch in 48 inches, noncumulative.
- B. Variation from Alignment with Surfaces: Plus or minus 1/16 inch in 48 inches, noncumulative.
- C. Variation from Level or Slope: Plus or minus 1/8 inch.
- D. Variation of Joint Width: Not more than 1/16 inch variation from hairline in 48 inches, noncumulative.

3.4 ADJUSTING

- A. Adjust sags or twists that develop in ceiling units and replace materials which are damaged or faulty.

**NISQUALLY STATE PARK
NEW FULL SERVICE PARK – PHASE 2**

3.5 CLEANING

- A. Clean panels on completion of installation to remove dust and other foreign materials according to manufacturer's written instructions.

3.6 PROTECTION

- A. Protect installed Work from damage due to subsequent construction activity, including temperature and humidity limitations and dust control, so that Work will be without damage and deterioration at time of Substantial Completion.

END OF SECTION

**NISQUALLY STATE PARK
NEW FULL SERVICE PARK – PHASE 2**

SECTION 099000 – PAINTING AND COATING

PART 1 - GENERAL

1.1 SUMMARY

A. Section Includes:

1. Surface preparation and application of painting and coating systems on exterior and interior substrates indicated in Painting Schedules in Part 3 and indicated on Drawings.
2. Items indicated in Specifications to be field-painted.

1.2 DEFINITIONS

A. Paint glosses are defined as sheen ratings of applied paint, according to ASTM D523 and the following MPI values:

1. Gloss Level 1 (Matte or Flat): 0 to 5 units at 60 deg; 10 units maximum at 85 deg.
2. Gloss Level 2 (Velvet): 0 to 10 units at 60 deg; 10 to 35 units at 85 deg.
3. Gloss Level 3 (Eggshell): 10 to 25 units at 60 deg; 10 to 35 units at 85 deg.
4. Gloss Level 4 (Satin): 20 to 35 units at 60 deg, minimum 35 units at 85 deg.
5. Gloss Level 5 (Semi-Gloss): 35 to 70 units at 60 deg.
6. Gloss Level 6 (Gloss): 70 to 85 units at 60 deg.

1.3 ACTION SUBMITTALS

A. Product Data: For each type of product, include.

1. Printout of current "MPI Approved Products List" for each product category specified, with proposed product highlighted.
2. Preparation requirements and application instructions.

B. Samples for Verification: For each type of paint system and in each color and gloss of topcoat.

1. Submit Samples on rigid backing, 8 inches square.
2. Apply coats on Samples in steps to show each coat required for system.
3. Label each coat of each Sample.
4. Label each Sample for location and application area.

C. Product List: For each product indicated, include the following:

1. Cross-reference to paint system and locations of application areas. Use same designations indicated on Drawings and in schedules.
2. Printout of current "MPI Approved Products List" for each product category specified in Part 2, with proposed product highlighted.
3. Color designations.

**NISQUALLY STATE PARK
NEW FULL SERVICE PARK – PHASE 2**

1.4 INFORMATIONAL SUBMITTALS

- A. Qualification Data: For applicator.

1.5 MAINTENANCE MATERIAL SUBMITTALS

- A. Furnish extra materials, from same product run, that match products installed and that are packaged with protective covering for storage and identified with labels describing contents.

1. Paint: 5 percent, but not less than 1 gal. of each material and color applied.

1.6 QUALITY ASSURANCE

- A. Applicator Qualifications: Company specializing in performing type of work of this Section with a minimum of 3 years documented experience.

1.7 DELIVERY, STORAGE, AND HANDLING

- A. Store materials not in use in tightly covered containers in well-ventilated areas with ambient temperatures continuously maintained at not less than 45 deg F.

1. Maintain containers in clean condition, free of foreign materials and residue.
2. Remove rags and waste from storage areas daily.

1.8 FIELD CONDITIONS

- A. Apply paints only when temperature of surfaces to be painted and ambient air temperatures are between 50 and 95 deg F.
B. Do not apply paints when relative humidity exceeds 85 percent; at temperatures less than 5 deg F above the dew point; or to damp or wet surfaces.

PART 2 - PRODUCTS

2.1 MANUFACTURERS

- A. Source Limitations: Obtain each paint product from single source from single manufacturer.

2.2 PAINT PRODUCTS, GENERAL

- A. MPI Standards: Provide products that comply with MPI standards indicated and listed in its "MPI Approved Products Lists."

1. If a manufacturer produces more than one product within an MPI category, provide highest quality product within that category.

**NISQUALLY STATE PARK
NEW FULL SERVICE PARK – PHASE 2**

- B. Material Quality: Material containers not displaying coating manufacturer’s product identification will not be accepted.
- C. Material Compatibility:
 - 1. Provide materials for use within each paint system that are compatible with one another and substrates indicated, under conditions of service and application as demonstrated by manufacturer, based on testing and field experience.
 - 2. For each coat in a paint system, provide products recommended in writing by topcoat manufacturers for use in paint system and on substrate indicated.
 - 3. Provide products of same manufacturer for each coat in a coating system.

2.3 PRIMERS/SEALERS

- A. Primer Sealer, Latex, Interior: MPI #50.

- 1. Products: Subject to compliance with requirements, provide one of the following:
 - a. Benjamin Moore: Ultra Spec 500, Waterborne Interior Primer Sealer, N534/K534.
 - b. PPG Architectural: Pure Performance Interior Latex Primer, 9-900.
 - c. Rodda Paint Co.: Master Painter Zero, Roseal Primer, 403601.
 - d. Sherwin-Williams: ProMar 200 Zero, Interior Latex Primer, B28W02600.

- B. Primer Sealer, Latex, Interior: MPI #61.

- 1. Products: Subject to compliance with requirements, provide one of the following:
 - a. Benjamin Moore: Insl-X, Vapor Barrier Primer/Sealer, VB-5000.
 - b. PPG Architectural: PPG Paints, Seal Grip Perm Sealer Vapor Barrier, 17-9801.
 - c. Rodda Paint: Interior Perm Rated Primer/Sealer, Vapor Block, 507901.
 - d. Sherwin-Williams: Moisture Vapor Barrier, Interior Latex Primer/Sealer, B72W00011.
 - e. Tnemec, Inc.: PVA Sealer, Series 51.

2.4 WOOD PRIMERS

- A. Primer, Latex, for Interior Wood, MPI #39.

- 1. Products: Subject to compliance with requirements, provide one of the following:
 - a. Benjamin Moore: Fresh Start, Multi-Purpose Latex primer, N023/F023.
 - b. PPG Architectural: PPG Paints, Seal Grip Interior/Exterior Acrylic Universal Primer/Sealer, 17-921XI Series.
 - c. Sherwin-Williams: Multi-Purpose, Multi-Purpose Latex Primer/Sealer, B51W00450.

**NISQUALLY STATE PARK
NEW FULL SERVICE PARK – PHASE 2**

2.5 WATER-BASED PAINTS

A. Latex, Exterior Satin, MPI #15.

1. Products: Subject to compliance with requirements, provide one of the following:
 - a. Benjamin Moore: Ultra Spec EXT, Exterior Satin Finish, N448/K448.
 - b. PPG Architectural: PPG Paints, Speedhide Exterior 100% Acrylic Latex Satin, 6-2045XI Line.
 - c. Sherwin-Williams: A-100, Exterior Latex Satin, A82W00151.

B. Latex, Interior, Eggshell, MPI #52.

1. Products: Subject to compliance with requirements, provide one of the following:
 - a. Benjamin Moore: Ultra Spec 500, Interior Eggshell, T538/F538.
 - b. PPG Architectural: PPG Paints, Speedhide Zero Interior Zero VOC Latex Satin, 6-4410XI.
 - c. Sherwin-Williams: ProMar 200 Zero VOC, Interior Latex Eg-Shel, B20W12651.

C. Latex, Interior, Satin, MPI #43.

1. Products: Subject to compliance with requirements, provide one of the following:
 - a. Benjamin Moore: Ultra Spec 500, Interior Satin/Pearl, T545/F545.
 - b. PPG Architectural: PPG, Speedhide Interior Latex Paint Lo Lustre, 6-3011.
 - c. Sherwin-Williams: ProMar 200 Zero VOC, Interior Latex Semi-Gloss, B31W02651.

D. Latex, Interior, Semi-Gloss, MPI #54.

1. Products: Subject to compliance with requirements, provide one of the following:
 - a. Benjamin Moore: Ultra Spec 500, Interior Semi-Gloss, T546/F546.
 - b. PPG Architectural: PPG Paints, Speedhide Zero Interior Zero VOC Latex Semi-Gloss, 6-4510XI.
 - c. Sherwin-Williams: ProMar 200 Zero VOC, Interior Latex Gloss, B21W12651.
2. Application: Mildew-resistant coating for use in areas subject to mold and mildew.

PART 3 - EXECUTION

3.1 EXAMINATION

A. Maximum Moisture Content of Substrates: When measured with an electronic moisture meter as follows:

1. Fiber-Cement Board: 12 percent.
2. Wood: 15 percent.
3. Gypsum Board: 12 percent.

**NISQUALLY STATE PARK
NEW FULL SERVICE PARK – PHASE 2**

- B. Gypsum Board Substrates: Verify that finishing compound is sanded smooth.
- C. Verify suitability of substrates, including surface conditions and compatibility, with existing finishes and primers.
- D. Proceed with coating application only after unsatisfactory conditions have been corrected.
 - 1. Application of coating indicates acceptance of surfaces and conditions.

3.2 PREPARATION

- A. Comply with manufacturer's written instructions and recommendations in "MPI Architectural Painting Specification Manual" applicable to substrates and paint systems indicated.
- B. Remove hardware, covers, plates, and similar items already in place that are removable and are not to be painted. If removal is impractical or impossible because of size or weight of item, provide surface-applied protection before surface preparation and painting.
 - 1. After completing painting operations, use workers skilled in trades involved to reinstall items that were removed. Remove surface-applied protection if any.
- C. Clean substrates of substances that could impair bond of paints, including dust, dirt, oil, grease, and incompatible paints and encapsulants.
 - 1. Remove incompatible primers and reprime substrate with compatible primers or apply tie coat as required to produce coating systems indicated.
- D. Concrete Substrates: Remove laitance, glaze, efflorescence, curing compounds, form-release agents, dust, dirt, grease, oil, existing paint coatings, and other contaminants incompatible with specified coating.
 - 1. Do not coat surfaces if moisture content or alkalinity of surfaces to be coated exceeds that permitted in manufacturer's written instructions.
 - 2. Abrasive-blast clean surfaces to comply with SSPC-SP 13/NACE No. 6 or ICRI No. 310.2R CSP 1-3 to achieve minimum surface profile recommended by epoxy coating manufacturer.
 - a. Use apparatus that abrades concrete surface, contains dispensed shot within apparatus, and recirculates shot by vacuum pickup.
- E. Steel Substrates: Remove rust, loose mill scale, and shop primer, if any. Clean using methods recommended in writing by paint manufacturer but not less than the following:
 - 1. Interior Steel: SSPC-SP 3.
 - 2. Exterior Steel: SSPC-SP 6 (WAB)/NACE WAB-3.
- F. Shop-Primed Steel Substrates: Clean field welds, bolted connections, and areas where shop paint is abraded. Paint exposed areas with the same material as used for shop priming to comply with SSPC-PA 1 for touching up shop-primed surfaces.

**NISQUALLY STATE PARK
NEW FULL SERVICE PARK – PHASE 2**

G. Wood Substrates:

1. Scrape and clean knots, and apply coat of knot sealer before applying primer.
2. Sand surfaces that will be exposed to view, and dust off.
3. Prime edges, ends, faces, undersides, and backsides of wood.
4. After priming, fill holes and imperfections in the finish surfaces with putty or plastic wood filler. Sand smooth when dried.

3.3 APPLICATION

A. Apply paints according to manufacturer's written instructions and to recommendations in "MPI Manual."

1. Use applicators and techniques suited for paint and substrate indicated.
 2. Paint surfaces behind movable equipment and furniture same as similar exposed surfaces. Before final installation, paint surfaces behind permanently fixed equipment or furniture with prime coat only.
 3. Paint front and backsides of access panels, removable or hinged covers, and similar hinged items to match exposed surfaces.
 4. Do not paint over labels of independent testing agencies or equipment name, identification, performance rating, or nomenclature plates.
 5. Primers specified in painting schedules may be omitted on items that are factory primed or factory-finished if acceptable to topcoat manufacturers.
- B. Tint each undercoat a lighter shade to facilitate identification of each coat if multiple coats of same material are to be applied. Tint undercoats to match color of topcoat, but provide sufficient difference in shade of undercoats to distinguish each separate coat.
- C. If undercoats or other conditions show through topcoat, apply additional coats until cured film has a uniform paint finish, color, and appearance.
- D. Apply paints to produce surface films without cloudiness, spotting, holidays, laps, brush marks, roller tracking, runs, sags, ropiness, or other surface imperfections. Cut in sharp lines and color breaks.

3.4 FIELD QUALITY CONTROL

A. Dry Film Thickness Testing: Owner may engage services of a qualified testing and inspecting agency to inspect and test paint for dry film thickness.

1. Touch up and restore painted surfaces damaged by testing.
2. If test results show that dry film thickness of applied paint does not comply with paint manufacturer's written recommendations, pay for testing and apply additional coats as needed to provide dry film thickness that complies with paint manufacturer's written recommendations.

**NISQUALLY STATE PARK
NEW FULL SERVICE PARK – PHASE 2**

3.5 CLEANING

- A. At end of each workday, remove rubbish, empty cans, rags, and other discarded materials from Project site.
- B. After completing paint application, clean spattered surfaces.
 - 1. Remove spattered paints by washing, scraping, or other methods.
 - 2. Do not scratch or damage adjacent finished surfaces.

3.6 PROTECTION

- A. Protect Work of other trades against damage from paint application.
 - 1. Correct damage to Work of other trades by cleaning, repairing, replacing, and refinishing, as approved by Architect, and leave in an undamaged condition.
- B. At completion of construction activities of other trades, touch up and restore damaged or defaced painted surfaces.

3.7 EXTERIOR PAINTING SCHEDULE

- A. Steel Substrates:
 - 1. Specified in Section 099600 – High Performance Coatings.
- B. Fiber-Cement Substrates:
 - 1. Latex over Shop Primer System:
 - a. Prime Coat: Shop-primed.
 - b. Intermediate Coat: Latex, exterior, matching topcoat.
 - c. Topcoat: Latex, exterior, satin, MPI #15.
 - 2. Applications: Fiber-cement panels, siding, soffits, and trim.

3.8 INTERIOR PAINTING SCHEDULE

- A. Steel Substrates:
 - 1. Specified in Section 099600 – High Performance Coatings.
- B. Wood Substrates:
 - 1. Latex over Latex Primer System:
 - a. Prime Coat: Primer, latex, for interior wood, MPI #39.
 - b. Intermediate Coat: Latex, interior, matching topcoat.

**NISQUALLY STATE PARK
NEW FULL SERVICE PARK – PHASE 2**

- c. Topcoat: Latex, interior, satin (MPI Gloss Level 4), MPI #43.
- d. Applications: Wood trim indicated for opaque finish.

C. Gypsum Board Substrates:

1. Latex over Latex Sealer System:

- a. Prime Coat: Primer sealer, latex, interior, MPI #50.
- b. Intermediate Coat: Latex, interior, matching topcoat.
- c. Topcoat: Latex, interior, eggshell (MPI Gloss Level 3), MPI #52.
- d. Topcoat: Latex, interior, satin (MPI Gloss Level 4), MPI #43.
- e. Topcoat: Latex, interior, semi-gloss (MPI Gloss Level 5), MPI #54.
- f. Application:

- 1) Interior gypsum board not at exterior wall conditions.

g. Sheen:

- 1) MPI #52: Soffits and ceilings.
- 2) MPI #43: Walls, soffits, ceilings, and other vertical conditions unless indicated otherwise.
- 3) MPI #54: Janitorial and maintenance rooms, toilet rooms, and other surfaces requiring semi-gloss finish.
- 4) Note: Ensure surfaces receiving MPI #54 topcoat have a Level 5 drywall finish.

2. Latex over Latex Sealer System, Low Permeability:

- a. Prime Coat: Primer sealer, low permeability, latex, interior, MPI #61.
- b. Intermediate Coat: Latex, interior, matching topcoat.
- c. Topcoat: Latex, interior, eggshell (MPI Gloss Level 3), MPI #52.
- d. Topcoat: Latex, interior, satin (MPI Gloss Level 4), MPI #43.
- e. Topcoat: Latex, interior, semi-gloss (MPI Gloss Level 5), MPI #54.
- f. Applications:

- 1) Interior gypsum board at exterior wall conditions.
- 2) Apply only primer on gypsum board partitions schedule to receive FRP finishes.

g. Sheen:

- 1) MPI #43: Walls and other vertical conditions unless indicated otherwise.

- h. Note: Ensure surfaces receiving MPI #54 topcoat have a Level 5 drywall finish.

D. Interior of Ducts, Grilles, and Diffusers:

1. Latex System:

- a. 2 coats latex, interior, flat, MPI #53.

2. Color: Black.

- 3. Application: From behind grilles and diffusers to 12 inches inside of ducts.

**NISQUALLY STATE PARK
NEW FULL SERVICE PARK – PHASE 2**

- E. Exposed Ducts, Grilles, Diffusers, and Piping:
1. Latex over water-based rust-inhibitive primer.
 - a. Prime Coat: Water-based rust-inhibitive primer.
 - b. Intermediate Coat: Latex, interior, matching topcoat.
 - c. Topcoat: Latex, interior, eggshell, MPI #52.
 - d. Topcoat: Latex, interior, satin, MPI #43
 - e. Topcoat: Latex, interior, semi-gloss, MPI #54.
 2. Color: Match color and sheen of adjacent walls and ceilings.
 - a. Refer to Sheen under Gypsum Board Substrates.
 3. Application: Exposed ducts, grilles, diffusers, and piping on or adjacent to walls and ceilings

END OF SECTION

**NISQUALLY STATE PARK
NEW FULL SERVICE PARK – PHASE 2**

SECTION 099300 – STAINING AND TRANSPARENT FINISHING

PART 1 - GENERAL

1.1 SUMMARY

A. Section Includes:

1. Transparent finishes.

1.2 DEFINITIONS

A. Paint glosses are defined as sheen ratings of applied paint, according to ASTM D523:

1. MPI Gloss Level 5 (Semi-Gloss): 35 to 70 units at 60 deg.
2. MPI Gloss Level 6 (Gloss): 70 to 85 units at 60 deg.

1.3 ACTION SUBMITTALS

A. Product Data:

1. For each type of product.
2. Include preparation requirements and application instructions.
3. Indicate VOC content.

B. Samples for Verification: Sample for each type of finish system and in each color and gloss of finish required on representative samples of actual wood substrates.

1. Size: 8 in. sq. or 8 in. long.
2. Apply coats on Samples in steps to show each coat required for system.
3. Label each coat of each Sample.
4. Label each Sample for location and application area.

C. Product List: For each product indicated, include the following:

1. Cross-reference to paint system and locations of application areas. Use same designations indicated on Drawings and in schedules.
2. Printout of current "MPI Approved Products List" for each product category specified in Part 2, with proposed product highlighted.

**NISQUALLY STATE PARK
NEW FULL SERVICE PARK – PHASE 2**

1.4 MAINTENANCE MATERIAL SUBMITTALS

- A. Extra Stock Material: Furnish extra materials, from same product run, that match products installed and that are packaged with protective covering for storage and identified with labels describing contents.
 - 1. Transparent Finishes: 5 percent, but not less than 1 gal. of each material and color applied.

1.5 QUALITY ASSURANCE

- A. Field Samples:
 - 1. Build field samples of each finishing system indicated.
 - 2. Architect will select one surface of each type of surface receiving transparent finish to represent surfaces and conditions for application of each finishing system.
 - 3. Approval of field samples does not constitute approval of deviations from Contract Documents contained in field samples unless Architect specifically approves such deviations in writing.

1.6 DELIVERY, STORAGE, AND HANDLING

- A. Store materials not in use in tightly covered containers in well-ventilated areas with ambient temperatures continuously maintained at not less than 45 deg F.
 - 1. Maintain containers in clean condition, free of foreign materials and residue.
 - 2. Remove rags and waste from storage areas daily.

1.7 FIELD CONDITIONS

- A. Apply finishes only when temperature of surfaces to be finished and ambient air temperatures are between 50 and 95 deg F.
- B. Do not apply finishes when relative humidity exceeds 85 percent, at temperatures of less than 5 deg F above the dew point, or to damp or wet surfaces.
- C. Do not apply exterior finishes in snow, rain, fog, or mist.

PART 2 - PRODUCTS

2.1 SOURCE LIMITATIONS

- A. Source Limitations: Obtain each coating product from single source from single manufacturer.

**NISQUALLY STATE PARK
NEW FULL SERVICE PARK – PHASE 2**

2.2 MATERIALS, GENERAL

A. Material Compatibility:

1. Provide materials for use within each coating system that are compatible with one another and substrates indicated, under conditions of service and application as demonstrated by manufacturer, based on testing and field experience.

2.3 TRANSPARENT FINISHES

A. Varnish, with UV Inhibitor, Exterior, Gloss (MPI Gloss Level 6), MPI #29:

1. Products: Subject to compliance with requirements, provide one of the following:
 - a. Behr Paint Company: Behr, Oil-Based Spar Urethane Semi-Gloss, B7202.
 - b. Cloverdale Paint: Timberlox, Super Spar Varnish, 43174.
 - c. PPG Paints: Defthane Interior/Exterior Polyurethane Gloss, DFT21.
 - d. Sherwin-Williams: Minwax, Helmsman Spar Varnish, 3200.
 - e. Approved substitution.

B. Varnish, Interior, Water Based, Clear, Semigloss (MPI Gloss Level 5), MPI #129:

1. Products: Subject to compliance with requirements, provide one of the following:
 - a. Behr Paint Company: Behr, Fast-Drying Water-Based Polyurethane Semi-Gloss, B8102.
 - b. PPG Paints: DEFT, Interior Water Based Acrylic Polyurethane, Semi-Gloss, DFT158.
 - c. Sherwin-Williams: Minwax, Polycrylic Protective Finish Gloss, 4444.
 - d. Sherwin-Williams: Minwax, Water Based Polyurethane Clear Semi-Gloss, 63020.

PART 3 - EXECUTION

3.1 EXAMINATION

- A. Examine substrates and conditions, with Applicator present, for compliance with requirements for maximum moisture content and other conditions affecting performance of the Work.
- B. Verify suitability of substrates, including surface conditions and compatibility with existing finishes and primers.
- C. Proceed with finish application only after unsatisfactory conditions have been corrected.
 1. Beginning finish application constitutes Contractor's acceptance of substrates and conditions.

**NISQUALLY STATE PARK
NEW FULL SERVICE PARK – PHASE 2**

3.2 PREPARATION

- A. Remove hardware, covers, plates, and similar items already in place that are removable. If removal is impractical or impossible because of size or weight of item, provide surface-applied protection before surface preparation and finishing.
 - 1. After completing finishing operations, use workers skilled in the trades involved to reinstall items that were removed. Remove surface-applied protection if any.
- B. Clean and prepare surfaces to be finished according to manufacturer's written instructions for each substrate condition and as specified.
 - 1. Remove dust, dirt, oil, and grease by washing with a detergent solution; rinse thoroughly with clean water and allow to dry. Remove grade stamps and pencil marks by sanding lightly. Remove loose wood fibers by brushing.
 - 2. Remove mildew by scrubbing with a commercial wash formulated for mildew removal and as recommended by stain manufacturer.
- C. Exterior Wood Substrates:
 - 1. Scrape and clean knots, and apply coat of knot sealer before applying primer.
 - 2. Prime edges, ends, faces, undersides, and backsides of wood.
 - a. For solid hide stained wood, stain edges and ends after priming.
 - b. For varnish-coated stained wood, stain edges and ends and prime with varnish. Prime undersides and backsides with varnish.
 - 3. Countersink steel nails, if used, and fill with putty or plastic wood filler tinted to final color. Sand smooth when dried.
- D. Interior Wood Substrates:
 - 1. Scrape and clean knots, and apply coat of knot sealer before applying primer.
 - 2. Apply wood filler paste to open-grain woods to produce smooth, glasslike finish.
 - 3. Sand surfaces exposed to view and dust off.
 - 4. After priming, fill holes and imperfections in the finish surfaces with putty or plastic wood filler. Sand smooth when dry.

3.3 APPLICATION

- A. Apply finishes according to manufacturer's written instructions. Use applicators and techniques suited for finish and substrate indicated. Finish surfaces behind movable equipment and furniture same as similar exposed surfaces. Do not apply finishes over labels of independent testing agencies or equipment name, identification, performance rating, or nomenclature plates.
- B. Apply finishes to produce surface films without cloudiness, holidays, lap marks, brush marks, runs, ropiness, or other surface imperfections.

**NISQUALLY STATE PARK
NEW FULL SERVICE PARK – PHASE 2**

3.4 CLEANING

- A. At end of each workday, remove rubbish, empty cans, rags, and other discarded materials from Project site.
- B. After completing finish application, clean spattered surfaces.
 - 1. Remove spattered materials by washing, scraping, or other methods.
 - 2. Do not scratch or damage adjacent finished surfaces.

3.5 PROTECTION

- A. Protect Work of other trades against damage from finish application. Correct damage by cleaning, repairing, replacing, and refinishing, as approved by Architect, and leave in an undamaged condition.
- B. At completion of construction activities of other trades, touch up and restore damaged or defaced finished wood surfaces.

3.6 EXTERIOR WOOD-FINISH-SYSTEM SCHEDULE

- A. Wood Substrates, Glued-Laminated Construction: Factory finished as specified in Section 061800 – Glued-Laminated Construction.
- B. Wood Substrates, Dressed Lumber:
 - 1. Varnish System:
 - a. Prime Coat: Varnish matching topcoat.
 - b. First Intermediate Coat: Varnish matching topcoat.
 - c. Second Intermediate Coat: Varnish matching topcoat.
 - d. Topcoat: Varnish, with UV Inhibitor, Exterior, Gloss, MPI #29.
 - 2. Applications: Wood trim, casing, windows, fences.

3.7 INTERIOR WOOD-FINISH-SYSTEM SCHEDULE

- A. Wood Substrates, Dressed Lumber:
 - 1. Water-Based Varnish System:
 - a. Prime Coat: Match topcoat.
 - b. Intermediate Coat: Match topcoat.
 - c. Topcoat: Gloss, MPI #129.
 - 2. Applications: Wood trim, frames, and jambs.

END OF SECTION

**NISQUALLY STATE PARK
NEW FULL SERVICE PARK – PHASE 2**

SECTION 099600 – HIGH-PERFORMANCE COATINGS

PART 1 - GENERAL

1.1 SUMMARY

A. Section Includes:

1. Surface preparation and application of high-performance coating systems on exterior and interior substrates indicated in High-Performance Coating Schedules in Part 3 and indicated on Drawings.

1.2 DEFINITIONS

A. Paint glosses are defined as sheen ratings of applied paint, according to ASTM D523:

1. MPI Gloss Level 5 (Semi-Gloss): 35 to 70 units at 60 deg.
2. MPI Gloss Level 6 (Gloss): 70 to 85 units at 60 deg.

1.3 ACTION SUBMITTALS

A. Product Data: For each type of product.

1. Include Printout of current "MPI Approved Products List" for each product category specified, with proposed product highlighted.
2. Include preparation requirements and application instructions.

B. Samples for Verification: For each type of coating system and in each color and gloss of topcoat indicated.

1. Submit Samples on rigid backing, 8 inches square.
2. Step coats on Samples to show each coat required for system.
3. Label each coat of each Sample.
4. Label each Sample for location and application area.

C. Product List: For each product indicated, include the following:

1. Cross-reference to paint system and locations of application areas. Use same designations indicated on Drawings and in schedules.
2. Printout of current "MPI Approved Products List" for each product category specified in Part 2, with proposed product highlighted.
3. Color designations.

1.4 INFORMATIONAL SUBMITTALS

A. Qualification Data: For applicator.

**NISQUALLY STATE PARK
NEW FULL SERVICE PARK – PHASE 2**

1.5 MAINTENANCE MATERIAL SUBMITTALS

- A. Furnish extra materials, from same product run, that match products installed and that are packaged with protective covering for storage and identified with labels describing contents.
 - 1. Coatings: 5 percent, but not less than 1 gal. of each material and color applied.

1.6 QUALITY ASSURANCE

- A. Applicator Qualifications: Company specializing in performing type of work of this Section with a minimum of 3 years documented experience.
- B. Field Samples: Comply with Section 014336 – Field Samples.
 - 1. Architect will select 1 surface to represent surfaces and conditions for application of each coating system specified in Part 3.
 - a. Provide samples of at least 100 sq. ft.
 - b. Other Items: Architect will designate items or areas required.
 - 2. Final approval of color selections will be based on field samples.
 - a. If preliminary color selections are not approved, apply additional field samples of additional colors selected by Architect at no added cost to Owner.
 - 3. Approval of field samples does not constitute approval of deviations from Contract Documents contained in field samples unless Architect specifically approves such deviations in writing.
 - 4. Subject to compliance with requirements, approved field samples may become part of completed Work if undisturbed at time of Substantial Completion.

1.7 DELIVERY, STORAGE, AND HANDLING

- A. Store materials not in use in tightly covered containers in well-ventilated areas with ambient temperatures continuously maintained at not less than 45 deg F.
 - 1. Maintain containers in clean condition, free of foreign materials and residue.
 - 2. Remove rags and waste from storage areas daily.

1.8 FIELD CONDITIONS

- A. Apply coatings only when temperature of surfaces to be coated and surrounding air temperatures are between 50 and 95 deg F.
- B. Do not apply coatings when relative humidity exceeds 85 percent; at temperatures less than 5 deg F above the dew point; or to damp or wet surfaces.
- C. Do not apply exterior coatings in snow, rain, fog, or mist.

**NISQUALLY STATE PARK
NEW FULL SERVICE PARK – PHASE 2**

PART 2 - PRODUCTS

2.1 MANUFACTURERS

- A. Products: Subject to compliance with requirements, available products that may be incorporated into Work are listed in other Part 2 Articles for paint category indicated.

2.2 HIGH-PERFORMANCE COATINGS

- A. MPI Standards: Provide products complying with MPI standards indicated and listed in its "MPI Approved Products Lists."

1. If a manufacturer produces more than one product within an MPI category, provide highest quality product within that category.
2. Certain specified products are not listed within an MPI category but are approved to be part of the system in which they are specified.

- B. Material Quality: Material containers not displaying coating manufacturer's product identification will not be accepted.

- C. Material Compatibility: Provide materials for use within each paint system that are compatible with one another and substrates indicated, under conditions of service and application as demonstrated by manufacturer, based on testing and field experience.

1. For each coat in a paint system, provide products recommended in writing by topcoat manufacturers for use in paint system and on substrate indicated.
2. Provide products of same manufacturer for each coat in a coating system.

2.3 METAL PRIMERS

- A. Primer, Rust-Inhibitive, Water Based, MPI #107 (mod). Corrosion-resistant, acrylic primer.

1. Products: Subject to compliance with requirements, provide one of the following:
 - a. Benjamin Moore: Ultra Spec HP, Acrylic Metal Primer, HP04/FP04.
 - b. Sherwin-Williams: Pro Industrial, Pro-Cryl Universal Primer, B66W01310.
 - c. Tnemec Company, Inc.: Typoxy, Series 27WB.

2.4 EPOXY COATINGS

- A. Epoxy, Polyamide, High-Build, Low Gloss (MPI Gloss Level 5), MPI #108.

1. Products: Subject to compliance with requirements, provide one of the following:
 - a. Benjamin Moore: Corotech, Polyamide Epoxy Semi-Gloss, V400-91.
 - b. Carboline Company: Carboline, Carboguard 60.
 - c. PPG Architectural: Protective and Marine Coatings, Amerlock 600, AK600.

**NISQUALLY STATE PARK
NEW FULL SERVICE PARK – PHASE 2**

- d. Sherwin-Williams: Protective & Marine, Macropoxy 646 Fast Cure Epoxy, B58W00610.
- e. Tnemec Company, Inc.: Epoxoline, Series 22.

2.5 POLYURETHANE COATINGS

A. Polyurethane, 2-Component, Pigmented, Gloss, Water Based, Gloss.

1. Products: Subject to compliance with requirements, provide one of the following:

- a. Benjamin Moore: Corotech, Waterborne Urethane Gloss, V540.
- b. Sherwin-Williams: Pro Industrial, Waterbased Acrolon 100 Polyurethane, B65W00721.
- c. Tnemec Company, Inc.: Endura-Shield, Series 1080.

B. Polyurethane, Aliphatic Acrylic, 2-Component, Pigmented, Gloss (MPI Gloss Level 6), MPI #72.

1. Products: Subject to compliance with requirements, provide one of the following:

- a. Benjamin Moore: Corotech, Aliphatic Acrylic Urethane Gloss, V500.
- b. Carboline Company: Carbothane 134 VOC.
- c. PPG Architectural: Protective and Marine Coatings, Amershield VOC, AMV Series/AM-B.
- d. Sherwin-Williams: Protective & Marine, Acrolon 218 HS, B65W661/B65V600 Series.
- e. Tnemec Company, Inc.: Endura-Shield II, Series 1074.

PART 3 - EXECUTION

3.1 EXAMINATION

- A. Examine substrates and conditions, with Applicator present, for compliance with requirements for maximum moisture content and other conditions affecting performance of the Work.
- B. Verify suitability of substrates, including surface conditions and compatibility, with existing finishes and primers.
- C. Proceed with coating application only after unsatisfactory conditions have been corrected.
 - 1. Application of coating indicates acceptance of surfaces and conditions.

3.2 PREPARATION

- A. Comply with manufacturer's written instructions and recommendations in "MPI Architectural Painting Specification Manual" applicable to substrates and coating systems indicated.

**NISQUALLY STATE PARK
NEW FULL SERVICE PARK – PHASE 2**

- B. Remove hardware, covers, plates, and similar items already in place that are removable and are not to be painted.
 - 1. If removal is impractical or impossible because of size or weight of item, provide surface-applied protection before surface preparation and painting.
 - 2. After completing painting operations, use workers skilled in trades involved to reinstall items that were removed.
 - 3. Remove surface-applied protection if any.
- C. Clean substrates of substances that could impair bond of coatings, including dust, dirt, oil, grease, and incompatible paints and encapsulants.
 - 1. Remove incompatible primers and reprime substrate with compatible primers or apply tie coat as required to produce coating systems indicated.
- D. Steel Substrates: Remove rust, loose mill scale, and shop primer if any. Clean using methods recommended in writing by paint manufacturer but not less than the following:
 - 1. SSPC-SP 6/NACE No. 3.

3.3 APPLICATION

- A. Apply high-performance coatings according to manufacturer's written instructions and recommendations in "MPI Architectural Painting Specification Manual."
 - 1. Use applicators and techniques suited for coating and substrate indicated.
 - 2. Coat surfaces behind movable equipment and furniture same as similar exposed surfaces. Before final installation, coat surfaces behind permanently fixed equipment or furniture with prime coat only.
 - 3. Coat backsides of access panels, removable or hinged covers, and similar hinged items to match exposed surfaces.
 - 4. Do not apply coatings over labels of independent testing agencies or equipment name, identification, performance rating, or nomenclature plates.
- B. Tint each undercoat a lighter shade to facilitate identification of each coat if multiple coats of same material are to be applied. Tint undercoats to match color of finish coat, but provide sufficient difference in shade of undercoats to distinguish each separate coat.
- C. If undercoats or other conditions show through final coat, apply additional coats until cured film has a uniform coating finish, color, and appearance.
- D. Apply coatings to produce surface films without cloudiness, spotting, holidays, laps, brush marks, runs, sags, ropiness, or other surface imperfections. Produce sharp glass lines and color breaks.

3.4 FIELD QUALITY CONTROL

- A. Dry Film Thickness Testing: Owner may engage the services of a qualified testing and inspecting agency to inspect and test coatings for dry film thickness.

**NISQUALLY STATE PARK
NEW FULL SERVICE PARK – PHASE 2**

1. Contractor shall touch up and restore coated surfaces damaged by testing.
2. If test results show that dry film thickness of applied coating does not comply with coating manufacturer's written recommendations, Contractor shall pay for testing and apply additional coats as needed to provide dry film thickness that complies with coating manufacturer's written recommendations.

3.5 CLEANING

- A. At end of each workday, remove rubbish, empty cans, rags, and other discarded materials from Project site.
- B. After completing coating application, clean spattered surfaces. Remove spattered coatings by washing, scraping, or other methods. Do not scratch or damage adjacent finished surfaces.

3.6 PROTECTION

- A. Protect Work of other trades against damage from coating operation. Correct damage to Work of other trades by cleaning, repairing, replacing, and recoating, as approved by Architect, and leave in an undamaged condition.
- B. At completion of construction activities of other trades, touch up and restore damaged or defaced coated surfaces.

**NISQUALLY STATE PARK
NEW FULL SERVICE PARK – PHASE 2**

3.7 EXTERIOR HIGH-PERFORMANCE COATING SCHEDULE

A. Steel and Galvanized-Metal Substrates:

1. Pigmented Polyurethane over High-Build Epoxy System:
 - a. Prime Coat: Epoxy, high build, low gloss, MPI #108.
 - b. Intermediate Coat: Epoxy, high build, low gloss, MPI #108.
 - c. Topcoat: Polyurethane, 2 component, pigmented, gloss, MPI #72.
 - d. Applications:
 - 1) Exposed structural steel.
 - 2) Faces, ends, and edges of hollow metal doors and frames.
 - 3) Lintels.
 - 4) Pole construction connectors.
 - 5) Other ferrous metals unless indicated otherwise.

3.8 INTERIOR HIGH-PERFORMANCE COATING SCHEDULE

A. Steel Substrates:

1. Pigmented Water-Based, Polyurethane over Waterborne, Corrosion-Resistant Primer:
 - a. Prime Coat: Rust-Inhibitive, water based, MPI #107 (mod).
 - b. Intermediate Coat: Polyurethane, 2 component, pigmented, matching topcoat.
 - c. Topcoat: Polyurethane, 2-component, pigmented, water based, gloss.
 - d. Applications:
 - 1) Exposed structural steel.
 - 2) Faces, ends, and edges of hollow metal doors and frames.
 - 3) Lintels.
 - 4) Pole construction connectors.
 - 5) Other ferrous metals unless indicated otherwise.

END OF SECTION

**NISQUALLY STATE PARK
NEW FULL SERVICE PARK – PHASE 2**

SECTION 099623 – GRAFFITI-RESISTANT COATINGS

PART 1 - GENERAL

1.1 SUMMARY

A. Section Includes:

1. Graffiti-resistant coating with water repellent.
2. Graffiti removal products.

1.2 ADMINISTRATIVE REQUIREMENTS

A. Preinstallation Meetings: Conduct meeting at Project site.

1. Require attendance of parties directly affecting Work of this Section, including Contractor, Owner's Representative, applicator, and manufacturer's representative.
2. Review environmental regulations, test panel procedures, protection of surrounding areas and non-masonry surfaces, surface preparation, application, field quality control, final cleaning, and coordination with other Work

1.3 ACTION SUBMITTALS

A. Product Data: For each type of product. Include the following manufacturer's information:

1. Standard colors.
2. Printed application instructions.
3. Recommended number of coats for each type of substrate and spreading rate for each separate coat.

1.4 INFORMATIONAL SUBMITTALS

- A. Qualification Data: For Applicator.
- B. Product Certificates: For each type of water repellent.
- C. Preconstruction Test Reports: For water-repellent-treated substrates.
- D. Sample Warranty: For special warranty.

1.5 QUALITY ASSURANCE

- A. Manufacturer's Qualifications: Not less than 5 years of experience in actual production of specified products.

**NISQUALLY STATE PARK
NEW FULL SERVICE PARK – PHASE 2**

- B. Installer's Qualifications: Firm trained and certified by coating manufacturer, with not less than 5 years of experience installing systems similar in complexity to those required for this Project, including specific requirements indicated.
- C. Field Samples:
 - 1. Locate field samples on surfaces where directed by Architect.
 - a. Size: 6 ft. by 6 ft. for each type of coating and each type of substrate indicated.
 - 2. Apply coatings to test surfaces according to coating manufacturer's instructions.
 - a. Overlap coatings to illustrate appearance differences due to build-up at run-downs and overlapping coatings at adjacent applications on same wall.
 - b. Allow coating to cure properly, apply graffiti as directed by Owner or Architect, then remove graffiti.
 - c. Repeat tests as needed to determine acceptability based upon performance and appearance criteria
 - 3. Approval of field samples does not constitute approval of deviations from Contract Documents contained in field samples unless Architect specifically approves such deviations in writing.
 - 4. Retain and maintain field samples during construction in undisturbed condition as a standard for judging completed Work.

1.6 PRECONSTRUCTION TESTING

- A. Preconstruction Testing: Engage a qualified testing agency to perform preconstruction testing of graffiti-resistant coating on field samples.
 - 1. In addition to verifying performance requirements, use field samples to verify manufacturer's written instructions for application procedure and optimum rates of product application to substrates.
 - 2. Propose changes to materials and methods to suit Project.
 - 3. Notify Architect 7 days in advance of the dates and times when field samples will be tested.
- B. Absorption Testing:
 - 1. Perform absorption tests using RILEM Test No. II.4, water absorption under low pressure (pipe method).
 - 2. Test surfaces scheduled for water repellent coatings prior to and 5 days following application.
 - 3. The following results will be the basis for acceptable performance:
 - a. Clay brick, natural stone, cast-in-place concrete and precast concrete surfaces:
 - 1) 1.0 mil or less loss in 20 minutes.

**NISQUALLY STATE PARK
NEW FULL SERVICE PARK – PHASE 2**

1.7 DELIVERY, STORAGE, AND HANDLING

- A. Deliver materials to site In manufacturers original, unopened containers and packaging, bearing manufacturer's name label with the following information:
 - 1. Name of material.
 - 2. Manufacturer's stock number and date of manufacture.
 - 3. Manufacturer's name.
 - 4. Contents by volume for major pigment and vehicle constituents.
 - 5. Application Instructions.
 - 6. Color name and number (if applicable)
- B. Store materials not in use in tightly covered containers. Maintain containers used in storage of coating materials in a clean condition, free of foreign materials and residue.
- C. Protect materials from freezing where necessary.
 - 1. Keep storage area neat and orderly. Remove flammable rags and waste daily.
 - 2. Take precautions to ensure that workers and Work areas are adequately protected from fire hazards and health hazards resulting from handling, mixing, and application of coatings.

1.8 FIELD CONDITIONS

- A. Comply with manufacturer's recommendations regarding environmental conditions under which materials can be stored and applied.
- B. Proceed with application only when existing and forecasted weather and substrate conditions permit coatings to be applied according to manufacturers' written instructions and warranty requirements
- C. Environmental Requirements:
 - 1. Building has been closed in for not less than 30 days before treating wall assemblies.
 - 2. Ambient temperature is above 40 deg F and below 100 deg F and will remain so for 24 hours.
 - 3. Substrate is not frozen and substrate-surface temperature is above 40 deg F and below 100 deg F.
 - 4. Rain or snow is not predicted within 24 hours.
 - 5. Not less than 24 hours have passed since surfaces were last wet unless longer period is required by repellent manufacturer.
 - 6. Windy conditions do not exist that might cause water repellent to be blown onto vegetation or surfaces not intended to be treated.

1.9 WARRANTY

- A. Special Warranty: Manufacturer agrees to repair or replace graffiti-resistant coatings that fail within specified warranty period.
 - 1. Retreat defective areas by system manufacture as determined by Architect.

**NISQUALLY STATE PARK
NEW FULL SERVICE PARK – PHASE 2**

2. Manufacturer shall be responsible for providing labor and material to reseal areas where coating effectiveness does not meet specified limits.
3. Warranty Period: 10 years from date of Substantial Completion.

1.10 MAINTENANCE

A. Extra Materials:

1. Provide extra graffiti stripper material in quantities described below. Package with protective covering for storage and identify with labels describing contents. Deliver extra materials to Owner.
 - a. Graffiti Removal Quantity: 1 gallon per 2,500 square feet ounce of covered area.
 - b. Removal Agent: Packaged in 16 to 32 ounce bottles and boxed for storage.

PART 2 - PRODUCTS

2.1 MANUFACTURERS

- A. Source Limitations: Obtain graffiti-resistant coatings from single source from single manufacture.

2.2 PERFORMANCE CRITERIA

- A. Performance: Graffiti-resistant coatings shall meet the following performance requirements as determined by preconstruction testing on substrates representing those indicated for this Project.
- B. Water Absorption: Minimum 90 percent reduction of water absorption after 24 hours for treated compared to untreated specimens when tested according to the following:
1. Clay Brick: ASTM C67.
- C. Water-Vapor Transmission: Comply with one or both of the following:
1. Maximum 10 percent reduction water-vapor transmission of treated compared to untreated specimens, according to ASTM E96.
 2. Minimum 80 percent water-vapor transmission of treated compared to untreated specimens, according to ASTM D1653.
- D. Water Penetration and Leakage through Masonry: Minimum 90 percent reduction in leakage rate of treated compared to untreated specimens, according to ASTM E514.
- E. Durability: Maximum 5 percent loss of water-repellent performance after 2,500 hours of weathering according to ASTM G154, or comparable test standard, compared to water-repellent-treated specimens before weathering.

**NISQUALLY STATE PARK
NEW FULL SERVICE PARK – PHASE 2**

2.3 MATERIALS

- A. Graffiti-Resistant Coating with Water Repellent: Clear, solvent-based, silicone elastomer, water and graffiti resistant coating.
 - 1. Products: Subject to compliance with requirements, provide one of the following:
 - a. Professional Products of Kansas, Inc.: Professional Water Sealant & Anti-Graffitiant.
 - 1) First Coat: PWS-15 Super.
 - 2) Second Coat: PWS-8 Extra.
 - b. ProSoCo, Inc.: Sure Klean Weather Seal Blok-Guard & Graffiti Control Ultra 15.
 - c. Tnemec Inc.: Series V626 Dur A Pell GS.
 - d. Approved substitution.
 - 2. Performance Requirements:
 - a. Surface Appearance: No appreciable difference compared to non-coated surface.
 - b. Excellent ultraviolet light stability.
 - c. Cleanability: Level 3 when tested according to ASTM D6578.
- B. Graffiti Removal Product: Product approved or recommended by graffiti-resistant coating manufacturer and containing benzyl alcohol, designed to remove graffiti from anti-graffiti coating.
 - 1. Products: Subject to compliance with requirements, provide one of the following:
 - a. Franmar: Blue Bear 680HS Hard Surface Graffiti Remover.
 - b. Professional Products of Kansas, Inc.: Phase II Cleaner.
 - c. ProSoCo, Inc.: Defaser Eraser.
 - d. Rust-Oleum: Krud Kutter Graffiti Remover.
 - e. Approved substitution.

PART 3 - EXECUTION

3.1 PREPARATION

- A. Protect shrubs, metal, wood trim, glass, asphalt, and other building hardware during application from over-spray. Do not permit spray mist or liquid to drift onto surrounding properties.
- B. Ensure surfaces are free of cracks, dust, dirt, oil, grease, paint, laitance, and other surface contaminants that may affect appearance or performance of water repellent material using mid-pressure water (1,500 psi) and commercial paint strippers.
- C. Check compatibility of installed sealants and patching materials to be used with anti-graffiti coating.

**NISQUALLY STATE PARK
NEW FULL SERVICE PARK – PHASE 2**

3.2 APPLICATION

- A. Comply with manufacturer's recommendations applying at rates indicated on container label. Apply at temperature and weather conditions recommended manufacture.
- B. Apply coating to brick veneer.
- C. Thoroughly brush out surface residue until material completely penetrates into surface.
- D. Protect treated areas from rain and other surface water for a period of not less than 4 hours after application.
- E. Provide adequate ventilation and follow governmental safety regulations.

3.3 REPAIR

- A. Correct Work that does not conform to specified requirements or replace as directed by Owner at no additional cost or extension of time to Owner.

3.4 CLEANING

- A. Remove protective coverings from adjacent surfaces and other protected areas.
- B. Immediately clean over-sprayed coating from adjoining surfaces and surfaces soiled by sacrificial graffiti coating application as work progresses.
- C. At completion, remove from site excess material, debris, and waste resulting from this Work. Dispose of water repellent containers per state and local environmental regulations.

3.5 CLOSEOUT ACTIVITIES

- A. Demonstration: Manufacturer's representative shall provide demonstration of cleaning procedure to Owner after completion of application and surface has properly cured. Coordinate demonstration meeting with Owner and Owner's personnel.

END OF SECTION

**NISQUALLY STATE PARK
NEW FULL SERVICE PARK – PHASE 2**

SECTION 101100 – VISUAL DISPLAY UNIT

PART 1 - GENERAL

1.1 SUMMARY

A. Section Includes:

1. Visual display board assemblies.

1.2 ADMINISTRATIVE REQUIREMENTS

- A. Preinstallation Meeting: Conduct meeting at Project site.

1.3 ACTION SUBMITTALS

A. Product Data: For each type of product.

1. Include construction details, material descriptions, dimensions of individual components and profiles, finishes, and accessories for visual display units.

B. Shop Drawings: For visual display units.

1. Include plans, elevations, sections, details, and attachments to other Work.
2. Show locations of panel joints. Show locations of field-assembled joints for factory-fabricated units too large to ship in 1 piece.
3. Include sections of typical trim members.

C. Samples for Verification: For each type of visual display unit indicated.

1. Visual Display unit: Not less than 6 by 6 inches, mounted on substrate indicated for final Work.
 - a. Include 1 panel for each type, color, and texture required.
2. Trim: 6 inch long sections of each trim profile.
3. Accessories: Full-size Sample of each type of accessory.

D. Product Schedule: For visual display units. Use same designations indicated on Drawings.

1.4 INFORMATIONAL SUBMITTALS

- A. Qualification Data: For Installer.

**NISQUALLY STATE PARK
NEW FULL SERVICE PARK – PHASE 2**

- B. Product Test Reports: For each visual display unit, for tests performed by manufacturer and witnessed by a qualified testing agency.

1.5 CLOSEOUT SUBMITTALS

- A. Maintenance Data: For visual display units to include in maintenance manuals.

1.6 QUALITY ASSURANCE

- A. Installer Qualifications: An entity that employs installers and supervisors who are trained and approved by manufacturer.

- B. Mockups:

1. Build mockup of each type of visual display unit as shown on Drawings.
 - a. Include accessories if specified.
2. Approval of mockups does not constitute approval of deviations from Contract Documents contained in mockups unless Architect specifically approves such deviations in writing.
3. Subject to compliance with requirements, approved mockups may become part of completed Work if undisturbed at time of Substantial Completion.

1.7 DELIVERY, STORAGE, AND HANDLING

- A. Deliver factory-fabricated visual display units completely assembled in 1 piece.

1. If dimensions exceed maximum manufactured unit size, or if unit size is impracticable to ship in 1 piece, provide 2 or more pieces with joints in locations indicated on approved Shop Drawings.

1.8 FIELD CONDITIONS

- A. Environmental Limitations: Do not deliver or install visual display units until spaces are enclosed and weathertight, wet Work in spaces is complete and dry, Work above ceilings is complete, and temporary HVAC system is operating and maintaining ambient temperature and humidity conditions at occupancy levels during remainder of construction period.

1.9 WARRANTY

- A. Special Warranty for Porcelain-Enamel Face Sheets: Manufacturer agrees to repair or replace porcelain-enamel face sheets that fail in materials or workmanship within specified warranty period.

1. Failures include the following:
 - a. Surfaces lose original writing and erasing qualities.

**NISQUALLY STATE PARK
NEW FULL SERVICE PARK – PHASE 2**

- b. Surfaces exhibit crazing, cracking, or flaking.
 - 2. Warranty Work does not cover removal or reinstallation of defective surfaces.
 - 3. Warranty Period: Minimum of 50 years from date of Substantial Completion.
- B. Special Warranty for Tackboard Panels: Manufacturer agrees to repair or replace tackboard panels that fail in materials or workmanship within specified warranty period.
- 1. Warranty Period: Lifetime from date of Substantial Completion.

PART 2 - PRODUCTS

2.1 MANUFACTURERS

- A. Source Limitations: Obtain each type of visual display unit from single source from single manufacturer.

2.2 PERFORMANCE CRITERIA

- A. Surface-Burning Characteristics: Comply with ASTM E84; testing by a qualified testing agency. Identify products with appropriate markings of applicable testing agency.
 - 1. Flame-Spread Index: 25 or less.
 - 2. Smoke-Developed Index: 450 or less.

2.3 VISUAL DISPLAY BOARD ASSEMBLIES

- A. Visual Display Board Assemblies, Markerboards:
 - 1. Products: Subject to compliance with requirements, provide products by one of the following:
 - a. AJW Architectural Products: N102-1N Series.
 - b. ASI Visual Display Products: 9800 Series Trim System.
 - c. Claridge Products and Equipment, Inc.: Series 2 Markerboards, Chalkboards, & Tackboards.
 - d. Approved substitution.
- B. Visual Display Board Assemblies, Tackboards:
 - 1. Products: Subject to compliance with requirements, provide products by one of the following:
 - a. AJW Architectural Products: N21F-0B Series.
 - b. ASI Visual Display Products: 9800 Series Trim System.
 - c. Claridge Products and Equipment, Inc.: Series 2.
 - d. Approved substitution.
- C. Visual Display Board Assemblies: Field or factory fabricated.

**NISQUALLY STATE PARK
NEW FULL SERVICE PARK – PHASE 2**

1. Assembly: Markerboards and tackboards.
 2. Corners: Square.
 3. Width: As indicated on Drawings.
 4. Height: As indicated on Drawings.
 5. Mounting Method: Direct to wall.
- D. Markerboard Panel: Porcelain-enamel-faced markerboard panel on core indicated.
1. Color: White unless indicated otherwise.
- E. Tackboard Panel: Natural-cork tackboard panel on core indicated.
1. Color and Pattern: As selected by Architect from full range of industry colors.
- F. Aluminum Frames and Trim: Fabricated from not less than 0.062inch thick, extruded aluminum; standard size and shape unless indicated otherwise.
1. Field-Applied Trim: Manufacturer's standard, concealed, screw-on trim.
 2. Face Width: 5/8 to 3/4 inch.
 3. Aluminum Finish: Clear anodic finish.
- G. Joints: Make joints only where total length exceeds maximum manufactured length. Fabricate with minimum number of joints, as acceptable to Architect or as indicated on approved Shop Drawings.
- H. Marker Tray: Manufacturer's standard; continuous type for use with markerboards.
1. Flat Type: Extruded aluminum with ribbed section and smoothly curved cast-aluminum end closures.

2.4 **MARKERBOARD PANELS**

- A. Porcelain-Enamel Markerboard Panels: Balanced, high-pressure, factory-laminated markerboard assembly of 3-ply construction, consisting of moisture-barrier backing, core material, and porcelain-enamel face sheet with high-gloss finish. Laminate panels under heat and pressure with manufacturer's standard, flexible waterproof adhesive.
1. Face Sheet Thickness: 0.021 inch uncoated base metal thickness.
 - a. Color: White.
 2. Core: Minimum 3/8 inch thick MDF or fiberboard, with manufacturer's standard moisture-barrier backing.
 3. Laminating Adhesive: Manufacturer's standard, moisture-resistant thermoplastic type.

**NISQUALLY STATE PARK
NEW FULL SERVICE PARK – PHASE 2**

2.5 TACKBOARD PANELS

A. Natural Cork Tackboard Panels:

1. Facing: 1/4 inch thick, self-healing, natural cork.
 - a. Color: As selected by Architect from manufacturer's full color range.
2. Core: Minimum 3/8 inch thick fiberboard.

B. Tackboard Panels, Natural Cork: Balanced, high pressure laminated, natural cork tackboards, 2 ply construction consisting of natural cork face sheet and backing core.

1. Facing: 1/4 inch thick, self-healing, natural cork.
2. Core: 1/4 inch thick hardboard.
3. Frames: Fabricated from 0.062 inch thick, extruded aluminum.
 - a. Frame Profile: 3/4 inch flat trim with square mitered, hairline corners.
 - b. Aluminum Finish: Clear anodic finish.

2.6 MATERIALS

A. Porcelain-Enamel Face Sheet: PEI-1002, with manufacturer's standard 2- or 3-coat process.

1. Face Sheet Thickness: 0.021 inch uncoated base metal thickness.

B. Natural-Cork Sheet: Seamless, single-layer, compressed fine-grain cork sheet; bulletin board quality; face sanded for natural finish; with surface-burning characteristics indicated.

C. Fiberboard: ASTM C208 cellulosic fiber insulating board.

D. Extruded Aluminum Bars and Shapes: ASTM B221, Alloy 6063.

2.7 FABRICATION

A. Fabricate visual display boards to requirements indicated for dimensions, design, and thickness and finish of materials.

2.8 ALUMINUM FINISHES

A. Clear Anodic Finish: AAMA 611, AA-M12C22A31, Class II, 0.010 mm or thicker.

B. Protect mechanical finishes on exposed surfaces from damage by applying a strippable, temporary protective covering before shipping.

**NISQUALLY STATE PARK
NEW FULL SERVICE PARK – PHASE 2**

PART 3 - EXECUTION

3.1 EXAMINATION

- A. Examine substrates and conditions, with Installer present, for compliance with requirements for installation tolerances, surface conditions of wall, and other conditions affecting performance of Work.
- B. Examine walls and partitions for proper preparation and backing for visual display units.
- C. Proceed with installation only after unsatisfactory conditions have been corrected.

3.2 PREPARATION

- A. Comply with manufacturer's written instructions for surface preparation.
- B. Clean substrates of substances that could impair performance of and affect smooth, finished surfaces of visual display boards, including dirt, mold, and mildew.
- C. Prepare surfaces to achieve a smooth, dry, clean surface free of flaking, unsound coatings, cracks, defects, projections, depressions, and substances that will impair bond between visual display units and wall surfaces.

3.3 INSTALLATION

- A. Install visual display units in compliance with manufacturer's written instructions in locations and at mounting heights indicated.
 - 1. Keep perimeter lines straight, level, and plumb.
 - 2. Provide grounds, clips, backing materials, brackets, anchors, trim, and accessories necessary for complete installation.
- B. Factory-Fabricated Visual Display Board Assemblies: Adhere or attach to surfaces as follows as recommended by visual display board manufacturer or as indicated on Drawings.
 - 1. Adhere to wall surfaces with egg-size adhesive gobs at 16 inches on center., horizontally and vertically.
 - 2. Attach concealed clips, hangers, and grounds to wall surfaces and to visual display boards with fasteners spaced as recommended by visual display board manufacturer.
 - a. Secure both top and bottom of boards to walls.
- C. Visual Display Board Assembly Mounting Heights:
 - 1. Install visual display units at mounting heights indicated on Drawings.

**NISQUALLY STATE PARK
NEW FULL SERVICE PARK – PHASE 2**

3.4 CLEANING AND PROTECTION

- A. Clean visual display units per manufacturer's written instructions. Attach one cleaning label to visual display unit in each room.
- B. Touch up factory-applied finishes to restore damaged or soiled areas.
- C. Cover and protect visual display units after installation and cleaning.

END OF SECTION

**NISQUALLY STATE PARK
NEW FULL SERVICE PARK – PHASE 2**

SECTION 101401 – REGULATORY SIGNAGE

PART 1 - GENERAL

1.1 SECTION INCLUDES

- A. Work herein shall include furnishing and installing all project regulatory (MUTCD) signs and signposts for the parking areas, and temporary signage for the Borrow Pit Haul Route.

1.2 REFERENCES

- A. Americans with Disabilities Act
- B. WSDOT Standard Specifications for Road, Bridge, and Municipal Construction current edition
- C. American Welding Society (AWS) Standard Welding Procedure Specifications
- D. WSDOT Standard Specifications for Road, Bridge, and Municipal Construction current edition
- E. ASTM A123 – Zinc (Hot Dip Galvanized) Coatings on Iron and Steel Products
- F. ASTM B209 - 10 Standard Specification for Aluminum and Aluminum Alloy Sheet and Plate
- G. ASTM D4956 - 11a Standard Specification for Retroreflective Sheeting for Traffic Control
- H. ASTM A500 / A500M - 10a Standard Specification for Cold-Formed Welded and Seamless Carbon Steel Structural Tubing in Rounds and Shapes
- I. ASTM A666-10 Standard Specification for Annealed or Cold-Worked Austenitic Stainless-Steel Sheet, Strip, Plate, and Flat Bar.
- J. ASTM A588/A588M-10 Standard Specifications for High-Strength Low-Alloy Structural Steel, up to 50 ksi (345 MPa) Minimum Yield Point, with Atmospheric Corrosion Resistance.
- K. ASTM A606/A606M-09a Standard Specifications for Steel, Sheet and Strip, High Strength, Low Alloy, Hot Rolled and Cold Rolled, with Improved Atmospheric Corrosion Resistance.
- L. ASTM B209M - 10 Standard Specification for Aluminum and Aluminum Alloy Sheet and Plate
- M. ASTM D1730 - 09 Standard Practices for Preparation of Aluminum and Aluminum-Alloy Surfaces for Painting
- N. ASTM D3451-05 Standard Guide for Testing Coating Powders and Powder Coatings
- O. ASTM D7378-10 Standard Practice for Measurement of Thickness of Applied Coating Powders to Predict Cured Thickness

**NISQUALLY STATE PARK
NEW FULL SERVICE PARK – PHASE 2**

- P. ASTM D7396 - 08 Standard Guide for Preparation of New, Continuous Zinc-Coated (Galvanized) Steel Surfaces for Painting

1.3 SUBMITTALS

- A. Submit under provisions of Section 013300 – Submittal Procedures.
- B. Shop Drawings: Show materials, dimensions, fasteners, blockings, joints, assembly and installation details for:
 - 1. Regulatory MUTCD Signs for parking areas
 - 2. Temporary Signage for the Borrow Pit Haul Route
- C. Samples: Actual material illustrating thickness, color, and finish:
 - 1. Regulatory MUTCD Signs: 4"x4" Sample of powder coated aluminum with vinyl letter attached.
- D. Graphic Proofs
 - 1. Submit graphic proof for each sign to be fabricated indicating overall dimensions, text size, spacing, font, colors, and attachments.
- E. Installer qualifications
 - 1. Submit firm profile and references from three projects of similar size and complexity as this project.

1.4 QUALITY ASSURANCE

- A. Fabricator/installer qualifications: Engage an installer with a minimum of 5 years of experience fabricating and installing signs of similar scope and complexity to this project.
- B. Welding Qualifications: Qualify procedures and personnel according to AWS D1.1/D1.1M, "Structural Welding Code - Steel."
 - 1. Welders and welding operators performing work on bottom-flange, demand-critical welds shall pass the supplemental welder qualification testing, as required by AWS D1.8. FCAW-S and FCAW-G shall be considered separate processes for welding personnel qualification.

1.5 STORAGE AND HANDLING

- A. Protect signs from damage during transportation. Store all materials off ground under protective covering.

**NISQUALLY STATE PARK
NEW FULL SERVICE PARK – PHASE 2**

PART 2 - PRODUCTS

2.1 POSTS

- A. Galvanized Steel: Hollow Steel Sections, in sizes indicated on drawings with closed top, drilled to accept fasteners, hot dip galvanized.

2.2 REGULATORY SIGNS

- A. All signage graphics shall conform to the latest edition of Manual for Uniform Traffic Control Devices and WSDOTSS 8-21 and 9-28.

B. Traffic, and ADA Signs:

1. Aluminum alloy: T6061-T6 Meeting ASTM B209
2. Facing Materials:
 - a. Traffic signs (Stop):
 - 1) Face: Reflective, weatherproof, adhesive sheeting meeting ASTM D4956, Scotchlite High Intensity sheeting series 3930 or approved equivalent
 - 2) Back: Powder coated
 - 3) 0.125-Inch-Thick Flat Sheet Aluminum per WSDOTSS 9-28.
 - 4) Graphic/symbols: machine-cut vinyl-3M Scotchcal #3470.
 - 5) All signage graphics shall conform to the latest edition of Manual for Uniform Traffic Control Devices and WSDOTSS 8-21 and 9-28.
 - b. ADA Signs:
 - 1) Face: Reflective, weatherproof, adhesive sheeting meeting ASTM D4956, Scotchlite Engineer Grade sheeting series 3430 or approved equivalent
 - 2) Back: Powder coated
 - 3) 0.125-Inch-Thick Flat Sheet Aluminum per WSDOTSS 9-28.
 - 4) Graphic/symbols: machine-cut vinyl-3M Scotchcal #3470.
 - 5) All signage graphics shall conform to the latest edition of Manual for Uniform Traffic Control Devices and WSDOTSS 8-21 and 9-28.

C. Temporary Borrow Pit Haul Route Signage Sandwich Sign

1. Plywood Placard: APA B-C, Exposure Durability Classification; Exterior; ½” thick.
2. Hinges shall be Galvanized Broad Utility Hinge with Galvanized 1” bolts size to fit hinge opening and two washes and nut per hinge opening.
3. Placard shall be vinyl coated canvas with 1” edges and grommets with message screen printed on.

**NISQUALLY STATE PARK
NEW FULL SERVICE PARK – PHASE 2**

PART 3 - EXECUTION

3.1 GENERAL

- A. Fabricate and install per Plans. Verify Sign location and orientation prior to fabrication and installation.

3.2 REGULATORY SIGNS

A. Fabrication

- 1. Fabricate from sheet material with thickness per WSDOT Standard Specifications 9-28.8
- 2. Fabricate signs with smooth edges and rounded corners.
- 3. Connect metal plates with continuous, watertight fillet welds, ground smooth for architectural finish per AWS standards.
- 4. Clean signs, prepare metal, and powder coat by electrostatic process.
 - a. Galvanized and zinc coated metal surfaces: Galvanize and apply thermosetting polyester/epoxy resin-based powdercoat.
 - b. Aluminum surfaces: Pre-treat per ASTM D1730 using a multi-stage chromate process or an approved chrome-free pretreatment process approved by Powder coating manufacturer for optimized weather resistance.
 - c. Apply coating materials to clean surfaces to minimum 2.5 - 3.5 mil dry film thickness or as specified by manufacturer.

- B. Preinstallation review: Stake locations of signs and obtain approval from WSP prior to installation.

- C. All signs shall be installed level and plumb as indicated per Drawings.

D. Posts

- 1. Install plumb and rotated so that face of sign is turned 3% toward direction of travel.
- 2. Crown top of concrete footing to shed water.

E. Signs

- 1. Install plumb and level with face of sign turned perpendicular to travel direction.
- 2. Attach signs to posts with tamper-proof stainless-steel fasteners. Install nylon or dielectric washers to separate dissimilar metal types. Apply Loctite on bolt threads before tightening nuts.

**NISQUALLY STATE PARK
NEW FULL SERVICE PARK – PHASE 2**

F. Accessible Parking Signs

1. Sign shall read “Van Accessible”. Attach sign face to steel post with galvanized u-bolts, washers, and nuts. Install post sleeve in 12 inch diameter by 2 foot deep concrete footing. Insert a minimum of 12 inches of sign post into sleeve and secure tightly with corresponding bolt, washer and nut. Mount bottom of sign face 5 feet from finish grade. Locate sleeve/footing per detail.

END OF SECTION

**NISQUALLY STATE PARK
NEW FULL SERVICE PARK – PHASE 2**

SECTION 101423 – PANEL SIGNAGE

PART 1 - GENERAL

1.1 SUMMARY

- A. Section Includes:
1. Rigid panel signs.
 2. Field-applied, vinyl-character signs.

1.2 ADMINISTRATIVE REQUIREMENTS

- A. Furnish templates for placement of sign-anchorage devices embedded in permanent construction by other installers.

1.3 ACTION SUBMITTALS

- A. Product Data:
1. Panel signs.
 2. Field-applied, vinyl-character signs.
- B. Shop Drawings: For panel signs.
1. Include fabrication and installation details and attachments to other Work.
 2. Show sign mounting heights, locations of supplementary supports to be provided by other installers, and accessories.
 3. Show message list, typestyles, graphic elements, and layout for each sign in size acceptable to Architect.
- C. Samples for Verification: For each type of sign assembly showing components and required finishes in manufacturer's standard size unless otherwise indicated and as follows:
1. Panel Signs: Not less than 12 inches square, including corner.
 2. Field-Applied, Vinyl-Character Signs: Full-size Sample of characters on glass.
 3. Variable Component Materials: Minimum 8 inch Sample of each base material, character (letter, number, and graphic element) in each exposed color and finish not included in Samples above.
 4. Exposed Accessories: Full-size Sample of each accessory type.
 5. Full-size Samples, if approved, will be returned to Contractor for use in Project.
- D. Product Schedule: For panel signs. Use same designations indicated on Drawings or as specified.

**NISQUALLY STATE PARK
NEW FULL SERVICE PARK – PHASE 2**

1.4 INFORMATIONAL SUBMITTALS

- A. Sample Warranty: For special warranty.

1.5 CLOSEOUT SUBMITTALS

- A. Maintenance Data: For signs to include in maintenance manuals.

1.6 MAINTENANCE MATERIAL SUBMITTALS

- A. Furnish extra materials, from same product run, that match products installed and that are packaged with protective covering for storage and identified with labels describing contents.

- 1. Variable Component Materials: 12 replaceable text inserts and interchangeable characters (letters, numbers, and graphic elements) of each type.
- 2. Tools: 1 sets of specialty tools for assembling signs and replacing variable sign components.

1.7 QUALITY ASSURANCE

- A. Fabricator Qualifications: Company specializing in fabricating specified types of signage with a minimum 3 years of experience of comparable scale and scope as this Project.

1.8 FIELD CONDITIONS

- A. Environmental Limitations: Do not deliver or install panel signage until spaces are enclosed and weathertight, wet Work in spaces is complete and dry, and temporary HVAC system is operating and maintaining ambient temperature and humidity conditions at occupancy levels during remainder of construction period.
- B. Field Measurements: Verify locations of anchorage devices embedded in permanent construction by other installers by field measurements before fabrication, and indicate measurements on Shop Drawings.

1.9 WARRANTY

- A. Special Warranty: Manufacturer agrees to repair or replace components of signs that fail in materials or workmanship within specified warranty period.

- 1. Failures include the following:
 - a. Deterioration of finishes beyond normal weathering.
 - b. Deterioration of embedded graphic image.
 - c. Separation or delamination of sheet materials and components.

- 2. Warranty Period: 5 years from date of Substantial Completion.

**NISQUALLY STATE PARK
NEW FULL SERVICE PARK – PHASE 2**

PART 2 - PRODUCTS

2.1 MANUFACTURER

- A. Fabricators: Subject to compliance with requirements, provide products from one of the following:
 - 1. ACE Sign Systems, Inc.
 - 2. Advance Corporation.
 - 3. ASI Sign Systems, Inc.
 - 4. Bunting Graphics, Inc.
 - 5. Nelson-Harkins Industries.
 - 6. Approved substitution.

- B. Source Limitations: Obtain each specified sign type from one source from single manufacturer.

2.2 PERFORMANCE CRITERIA

- A. Thermal Movements: For exterior signs, allow for thermal movements from ambient and surface temperature changes.
 - 1. Temperature Change: 120 deg F, ambient; 180 deg F, material surfaces.

- B. Accessibility Standard: Comply with applicable provisions in the USDOJ's "2010 ADA Standards for Accessible Design" and ICC A117.1.

- C. Structural Performance: Signs and supporting elements shall withstand effects of gravity and other loads within limits and under conditions indicated.
 - 1. Uniform and concentrated loads need not be assumed to act concurrently.

2.3 PANEL SIGNS

- A. Panel Signs, General: Signs with smooth, uniform surfaces; with message and characters having uniform faces, sharp corners, and precisely formed lines and profiles; and as indicated below.
 - 1. Solid-Sheet Signs: Signs fabricated from sheet material indicated below, with finish specified in "Surface Finish and Applied Graphics" Subparagraph.
 - 2. Flatness Tolerance: Sign shall remain flat or uniformly curved under installed conditions as indicated on Drawings and within a tolerance of plus or minus 1/16 inch measured diagonally from corner to corner.
 - 3. Laminated and sandblasted photopolymers, added-on characters, chemically-welded, characters, and engraved characters are not acceptable.

- B. Solid-Sheet Sign, Acrylic: Provide signs that are uniform in color and translucence.
 - 1. Thickness: Match existing panel signs.
 - 2. Surface-Applied, Flat Graphics: Applied vinyl film.
 - 3. Surface-Applied, Raised Graphics: Applied polymer characters and Braille.
 - 4. Translucence: Match existing panel signs.

**NISQUALLY STATE PARK
NEW FULL SERVICE PARK – PHASE 2**

5. Color: As selected by Architect from manufacturers color range.
6. Edges: Square-cut and finished with no visible saw marks.
7. Mounting: Surface mounted to wall with countersunk, security, flathead through-fasteners.

C. Surface Finish and Applied Graphics:

1. Integral Acrylic Sheet Color: Match existing panel signage.
2. Text and Typeface: Accessible raised characters and Braille, typeface matching existing panel signage, and variable content as scheduled.
 - a. Finish raised characters to contrast with background color.
 - b. Finish Braille to match background color.

2.4 PANEL-SIGN MATERIALS

- A. Acrylic Sheet: ASTM D4802; 1/16 inch thick, clear, non-glare, Type UVF; category as standard with manufacturer for each sign.

2.5 ACCESSORIES

- A. Fasteners and Anchors: Manufacturer's standard as required for secure anchorage of signs, noncorrosive and compatible with each material joined, and complying with the following:
 1. Provide concealed fasteners and anchors unless indicated to be exposed.
 2. Provide stainless-steel devices unless otherwise indicated.
 3. Sign Mounting Fasteners: Tamper-proof type devices.
 - a. Through Fasteners: Exposed metal fasteners matching sign finish, with type of head indicated, and installed in predrilled holes.
 4. Inserts: Furnish inserts to be set by other installers into concrete or masonry Work.

2.6 FABRICATION

- A. Provide manufacturer's standard sign assemblies according to requirements indicated.
 1. Preassemble signs in shop to greatest extent possible. Disassemble signs and assemblies only as necessary for shipping and handling limitations. Clearly mark units for reassembly and installation; apply markings in locations concealed from view after final assembly.
 2. Mill joints to a tight, hairline fit. Form assemblies and joints exposed to weather to resist water penetration and retention.
 3. Conceal connections if possible; otherwise, locate connections where they are inconspicuous.
 4. Provide rabbets, lugs, and tabs necessary to assemble components and to attach to existing work. Drill and tap for required fasteners. Use concealed fasteners where possible; use exposed fasteners that match sign finish.
 5. Apply graphics to second surface of clear face-sheet material to produce precisely formed image.
 6. Image shall be free of rough edges.

**NISQUALLY STATE PARK
NEW FULL SERVICE PARK – PHASE 2**

B. Shop- and Subsurface-Applied Vinyl:

1. Align vinyl film in final position and apply to surface.
2. Firmly press film from middle outward or as recommended by film manufacturer to obtain good bond without blisters or fishmouths.

PART 3 - EXECUTION

3.1 INSTALLATION

A. Install signs using mounting methods indicated and according to manufacturer's written instructions.

1. Install signs level, plumb, true to line, and at locations and heights indicated, with sign surfaces free of distortion and other defects in appearance.
2. Install signs so they do not protrude or obstruct according to accessibility standard.
3. Before installation, verify that sign surfaces are clean and free of materials or debris that would impair installation.
4. Corrosion Protection: Coat concealed surfaces of exterior aluminum in contact with grout, concrete, masonry, wood, or dissimilar metals, with a heavy coat of bituminous paint.

B. Accessible Signage: Install in locations on walls as indicated on Drawings and according to the accessibility standard.

C. Mounting Methods:

1. Through Fasteners: Drill holes in substrate using predrilled holes in sign as template.
 - a. Countersink holes in sign if required.
 - b. Place sign in position and flush to surface.
 - c. Install through fasteners and tighten.

D. Field-Applied, Vinyl-Character Signs:

1. Clean and dry substrate.
2. Align sign characters in final position before removing release liner.
3. Remove release liner in stages, and apply and firmly press characters into final position.
4. Press from middle outward or as recommended by film manufacturer to obtain good bond without blisters or fishmouths.
5. Remove carrier film without disturbing applied vinyl film.

E. Signs Mounted on Glass: Provide opaque sheet matching sign material and finish onto opposite side of glass to conceal back of sign.

3.2 ADJUSTING AND CLEANING

- A. Remove and replace damaged or deformed signs and signs that do not comply with specified requirements. Replace signs with damaged or deteriorated finishes or components that cannot be successfully repaired by finish touchup or similar minor repair procedures.

**NISQUALLY STATE PARK
NEW FULL SERVICE PARK – PHASE 2**

- B. Remove temporary protective coverings and strippable films as signs are installed.
- C. On completion of installation, clean exposed surfaces of signs according to manufacturer's written instructions, and touch up minor nicks and abrasions in finish. Maintain signs in a clean condition during construction and protect from damage until acceptance by Owner.

END OF SECTION

**NISQUALLY STATE PARK
NEW FULL SERVICE PARK – PHASE 2**

SECTION 10 14 23.16 – ROOM-IDENTIFICATION PANEL SIGNAGE

PART 1 - GENERAL

1.1 SUMMARY

A. Section Includes:

1. Room-identification signs.

1.2 ADMINISTRATIVE REQUIREMENTS

A. Coordination:

1. Furnish templates for placement of sign-anchorage devices embedded in permanent construction by other installers.

1.3 ACTION SUBMITTALS

A. Product Data: For each type of product.

B. Shop Drawings: For room-identification signs.

1. Include fabrication and installation details and attachments to other Work.
2. Show sign mounting heights and accessories.
3. Show message list, typestyles, graphic elements, including raised characters and Braille, and layout for each sign at least 1/2 size.

C. Samples for Verification: For each type of sign assembly showing components and required finishes, in manufacturer's standard size unless otherwise indicated and as follows:

1. Room-Identification Signs: Full-size Sample.
2. Variable Component Materials: 8 inch Sample of each base material, character (letter, number, and graphic element) in each exposed color and finish not included in Samples above.
3. Exposed Accessories: Full-size Sample of each accessory type.
4. Full-size Samples, if approved, will be returned to Contractor for use in Project.

D. Product Schedule: For room-identification signs. Use same designations indicated on Signage Detail Sheet.

1.4 INFORMATIONAL SUBMITTALS

A. Qualification Data: For Installer and fabricator.

**NISQUALLY STATE PARK
NEW FULL SERVICE PARK – PHASE 2**

1.5 CLOSEOUT SUBMITTALS

- A. Furnish extra materials, from same product run, that match products installed and that are packaged with protective covering for storage and identified with labels describing contents.

1.6 MAINTENANCE MATERIAL SUBMITTALS

- A. Furnish extra materials, from the same product run, that match products installed and that are packaged with protective covering for storage and identified with labels describing contents.
 - 1. Variable Component Materials: 12 replaceable text inserts and interchangeable characters (letters, numbers, and graphic elements) of each type.
 - 2. Tools: 1 set(s) of specialty tools for assembling signs and replacing variable sign components.

1.7 QUALITY ASSURANCE

- A. Fabricator Qualifications: Company specializing in fabricating specified types of signage with a minimum 3 years of experience of comparable scale and scope as this Project.

1.8 FIELD CONDITIONS

- A. Ambient Conditions: Do not deliver or install room identification signage until spaces are enclosed and weathertight, wet Work in spaces is complete and dry, and temporary HVAC system is operating and maintaining ambient temperature and humidity conditions at occupancy levels during remainder of construction period.
- B. Field Measurements: Verify locations of anchorage devices embedded in permanent construction by other installers by field measurements before fabrication, and indicate measurements on Shop Drawings.

1.9 WARRANTY

- A. Special Warranty: Manufacturer agrees to repair or replace components of signs that fail in materials or workmanship within specified warranty period.
 - 1. Failures include the following:
 - a. Deterioration of finishes beyond normal weathering.
 - b. Separation or delamination of sheet materials and components.
 - 2. Warranty Period: 5 years from date of Substantial Completion.

**NISQUALLY STATE PARK
NEW FULL SERVICE PARK – PHASE 2**

PART 2 - PRODUCTS

2.1 MANUFACTURER

- A. Fabricators: Subject to compliance with requirements, provide products from one of the following:
1. Best Sign Systems Inc.
 2. Center Pointe Signs.
 3. Neiman & Company Architectural Signage.
 4. Signtech
 5. Trade-Marx Sign & Display.
 6. Tube Art Group.
 7. Vertical Visual Solutions.
 8. Approved substitution.

2.2 PERFORMANCE CRITERIA

- A. Accessibility Standard: Comply with applicable provisions in the USDOJ's "2010 ADA Standards for Accessible Design" and ICC A117.1.

2.3 ROOM-IDENTIFICATION SIGNS

- A. Room-Identification Signage, General: Smooth, uniform surfaces; with messages and characters having uniform faces, sharp corners, and precisely formed lines and profiles.

1. Laminated photopolymers, added-on characters, and engraved characters are not acceptable.

- B. Interior Signs:

1. Composition: Moisture-resistant, non-glare, interior nylon, photopolymer on ultraviolet-resistant, clear PETG sign base, single piece construction.
2. Raised-Copy Thickness: 1/32 inch.
3. PETG-Sheet Thickness: 0.118 inch.
4. Composite Sheet Thickness: 0.15 inch.
5. Sizes: As indicated on Drawings.
6. Color: As selected by Architect from manufacturer's standard range of colors.
7. Surface Graphics: Applied photopolymer.
8. Subsurface Graphics: Slide-in changeable insert.
9. Sign Panel Perimeter:
 - a. Edge Conditions: Square cut, with smooth edges.
 - b. Corner Condition in Elevation: 1/16 inch radius.

10. Text and Pictographs:

- a. Type: Hot stamped.
- b. Foil Color: White.

**NISQUALLY STATE PARK
NEW FULL SERVICE PARK – PHASE 2**

- c. Typeface: Arial.
- d. Letter Height: As indicated on Drawings.

11. Mounting: 2-face tape.

C. Tactile and Braille:

- 1. Precisely form raised characters and Grade 2 Braille free from burrs and cut marks.
- 2. Grade 2 Braille Copy: Coordinate messages in conjunction as indicated. Braille copy indicated on Drawings is for size and position only. Do not use for full message.
 - a. Applied applique and bead Braille are not acceptable.

2.4 SIGN MATERIALS

- A. Acrylic Sheet: ASTM D4802; 1/16 inch thick, clear, non-glare, Type UVF; category as standard with manufacturer for each sign.
 - 1. Provide for signs indicated to have changeable message window.
- B. Modified Polyethelene Terephtalate Glycol (PETG): ASTM D5047, glycol-modified polyethylene terephtalate copolyester that is a clear amorphous thermoplastic.
- C. Nylon Photopolymer Film: Laminated, clear, polymer film that reacts to UV light forming a hard surface.
 - 1. Hardness: Shore D Hardness of 80 minimum after 14 day cure at 70 deg F.
- D. Vinyl Film: UV-resistant vinyl film with pressure-sensitive, permanent adhesive; die cut to form characters or images as indicated on Drawings.

2.5 ACCESSORIES

- A. Interior Sign Mounting: 2-Face Tape: Manufacturer's standard high-bond, foam-core tape, 0.045 inch thick, with adhesive on both sides.

2.6 FABRICATION

- A. Provide manufacturer's standard sign assemblies according to requirements indicated.
 - 1. Preassemble signs and assemblies in shop to greatest extent possible. Disassemble signs and assemblies only as necessary for shipping and handling limitations. Clearly mark units for reassembly and installation; apply markings in locations concealed from view after final assembly.
 - 2. Mill joints to a tight, hairline fit. Form assemblies and joints exposed to weather to resist water penetration and retention.

**NISQUALLY STATE PARK
NEW FULL SERVICE PARK – PHASE 2**

- B. Signs with Changeable Message Capability: Fabricate signs to allow insertion of changeable slide-in messages.
 - 1. Inserts: provide Changeable inserts.
 - 2. Fabrication: Fabricate window slot without burrs or constrictions that inhibit function. Fabricate window slot with 1/2 inch radius half-circle cut into message window to ease removal of changeable message insert material.

2.7 GENERAL FINISH REQUIREMENTS

- A. Protect finishes on exposed surfaces from damage by applying a strippable, temporary protective covering before shipping.
- B. Appearance of Finished Work: Noticeable variations in same piece are not acceptable. Variations in appearance of adjoining components are acceptable if they are within range of approved Samples and are assembled or installed to minimize contrast.

PART 3 - EXECUTION

3.1 EXAMINATION

- A. Examine substrates, areas, and conditions, with Installer present, for compliance with requirements for installation tolerances and other conditions affecting performance of Work.
- B. Verify that sign-substrates are within tolerances to accommodate signs without gaps or irregularities between backs of signs and support surfaces unless otherwise indicated.
- C. Proceed with installation only after unsatisfactory conditions have been corrected.

3.2 INSTALLATION

- A. Install signs using mounting methods indicated and according to manufacturer's written instructions.
 - 1. Install signs level, plumb, true to line, and at locations and heights indicated, with sign surfaces free of distortion and other defects in appearance.
 - 2. Install signs so they do not protrude or obstruct according to accessibility standard.
 - 3. Before installation, verify that sign surfaces are clean and free of materials or debris that would impair installation.
- B. Accessibility: Install signs in locations on walls as indicated on Drawings and according to accessibility standard.
- C. Mounting Methods:
 - 1. 2-Face Tape: Clean bond-breaking materials from substrate surface and remove loose debris. Apply tape strips symmetrically to back of sign and of suitable quantity to support weight of

**NISQUALLY STATE PARK
NEW FULL SERVICE PARK – PHASE 2**

sign without slippage. Place strips a minimum of 1/4 inch away from sign edge to prevent visibility at sign edges. Place sign in position, and push to engage tape adhesive.

- a. Application: Interior signage.

3.3 ADJUSTING AND CLEANING

- A. Remove and replace damaged or deformed signs and signs that do not comply with specified requirements. Replace signs with damaged or deteriorated finishes or components that cannot be successfully repaired by finish touchup or similar minor repair procedures.
- B. Remove temporary protective coverings and strippable films as signs are installed.
- C. On completion of installation, clean exposed surfaces of signs according to manufacturer's written instructions, and touch up minor nicks and abrasions in finish. Maintain signs in a clean condition during construction and protect from damage until acceptance by Owner.

END OF SECTION

**NISQUALLY STATE PARK
NEW FULL SERVICE PARK – PHASE 2**

SECTION 102613 – CORNER GUARDS

PART 1 - GENERAL

1.1 SUMMARY

A. Section Includes:

1. Corner guards.

1.2 ACTION SUBMITTALS

A. Product Data: For each type of product.

1. Include construction details, material descriptions, impact strength, dimensions of individual components and profiles, and finishes.

B. Samples for Verification: For each type of exposed finish on the following products, 12 inch long Samples.

1.3 INFORMATIONAL SUBMITTALS

A. Material Certificates: For each type of exposed plastic material.

B. Sample Warranty: For special warranty.

1.4 CLOSEOUT SUBMITTALS

A. Maintenance Data: For each type of corner guard product to include in maintenance manuals.

1.5 DELIVERY, STORAGE, AND HANDLING

A. Store corner guards in original undamaged packages and containers inside well-ventilated area protected from weather, moisture, soiling, extreme temperatures, and humidity.

1. Maintain room temperature within storage area at not less than 70 deg F during period plastic materials are stored.

1.6 MAINTENANCE MATERIAL SUBMITTALS

A. Furnish extra materials, from same product run, that match products installed and that are packaged with protective covering for storage and identified with labels describing contents.

**NISQUALLY STATE PARK
NEW FULL SERVICE PARK – PHASE 2**

1. Corner-Guard Covers: Full-size plastic covers of maximum length equal to 2 percent of each type, color, and texture of cover installed, but no fewer than two 48 inch long units.
2. Mounting and Accessory Components: Amounts proportional to quantities of extra materials. Package mounting and accessory components with each extra material.

1.7 WARRANTY

- A. Special Warranty: Manufacturer agrees to repair or replace components of corner guard units that fail in materials or workmanship within specified warranty period.
 1. Failures include manufacturing defects in metals, metal finishes, and workmanship.
 2. Warranty Period: 5 years from date of Substantial Completion.

PART 2 - PRODUCTS

2.1 MANUFACTURERS

- A. Source Limitations: Obtain corner guard products from single source from single manufacturer.

2.2 PERFORMANCE CRITERIA

- A. Surface Burning Characteristics: Comply with ASTM E84 or UL 723; testing by a qualified testing agency. Identify products with appropriate markings of applicable testing agency.
 1. Flame-Spread Index: 25 or less.
 2. Smoke-Developed Index: 450 or less.

2.3 CORNER GUARDS

- A. Surface-Mounted, Metal Corner Guards (CG-3): Fabricated as 1-piece, formed or extruded metal with formed edges; with 90- or 135-degree turn to match wall condition.
 1. Products: Subject to compliance with requirements, provide one of the following:
 - a. Construction Specialties, Inc.: CO-8 Series.
 - b. IPC Door and Wall Protection Systems, InPro Corporation: Model 18312X-304 Series.
 - c. Koroseal Wall Protection Systems: Korogard GS30 Series.
 - d. Pawling Corporation: Model CG-5X Series.
 - e. Approved substitution.
 2. Material: Stainless steel, Type 304.
 - a. Thickness: Minimum 0.062 inch.
 - b. Height: 48 inches unless indicated otherwise on Drawings.
 - c. Finish: Directional satin, No. 4.

**NISQUALLY STATE PARK
NEW FULL SERVICE PARK – PHASE 2**

3. Wing Size: Nominal 3-1/2 by 3-1/2 inches.
4. Corner Radius: 1/8 inch.
5. Mounting: Adhesive.
6. Application: Typical corner guard throughout building unless indicated otherwise.

2.4 MATERIALS

- A. Adhesive: As recommended by protection product manufacturer.

2.5 FABRICATION

- A. Fabricate corner guards according to requirements indicated for design, performance, dimensions, and member sizes, including thicknesses of components.
- B. Quality: Fabricate components with exposed edges rolled. Provide surfaces free of wrinkles, chips, dents, uneven coloration, and other imperfections. Fabricate members and fittings to produce flush, smooth, and rigid hairline joints.

2.6 FINISHES

- A. Protect finishes on exposed surfaces from damage by applying a strippable, temporary protective covering before shipping.
- B. Appearance of Finished Work: Noticeable variations in same piece are not acceptable. Variations in appearance of adjoining components are acceptable if they are within range of approved Samples and are assembled or installed to minimize contrast.

PART 3 - EXECUTION

3.1 EXAMINATION

- A. Examine substrates and wall areas, with Installer present, for compliance with requirements for installation tolerances and other conditions affecting performance of Work.
- B. Examine walls to which corner guards are attached with adhesive to verify compatibility with and suitability of substrates, including compatibility with existing finishes or primers.
- C. Proceed with installation only after unsatisfactory conditions have been corrected.

3.2 PREPARATION

- A. Complete finishing operations, including painting, before installing corner guards.
- B. Before installation, clean substrate to remove dust, debris, and loose particles.

**NISQUALLY STATE PARK
NEW FULL SERVICE PARK – PHASE 2**

3.3 INSTALLATION

- A. Installation Quality: Install corner guards according to manufacturer's written instructions, level, plumb, and true to line without distortions. Do not use materials with chips, cracks, voids, stains, or other defects that might be visible in finished Work.
- B. Mounting Heights: Install corner guards in locations and at mounting heights indicated on Drawings.

3.4 CLEANING

- A. Immediately after completion of installation, clean plastic covers and accessories using a standard ammonia-based household cleaning agent.
- B. Remove excess adhesive using methods and materials recommended in writing by manufacturer.

END OF SECTION

**NISQUALLY STATE PARK
NEW FULL SERVICE PARK – PHASE 2**

SECTION 102813 – TOILET AND BATH ACCESSORIES

PART 1 - GENERAL

1.1 SUMMARY

A. Section Includes:

1. Washroom and bathroom accessories.
2. Shower and tub accessories.
3. Underlavatory guards.

1.2 ADMINISTRATIVE REQUIREMENTS

A. Coordination:

1. Coordinate accessory locations with other Work to prevent interference with clearances required for access by people with disabilities, and for proper installation, adjustment, operation, cleaning, and servicing of accessories.

1.3 ACTION SUBMITTALS

A. Product Data: For each type of product.

1. Include construction details, material descriptions, dimensions of individual components and profiles, and finishes.
2. Include anchoring and mounting requirements, including requirements for cutouts in other Work and substrate preparation.

B. Product Schedule: Indicating types, quantities, sizes, and installation locations by room of each accessory required. Indicate Identify locations using room designations indicated.

1. Identify products using designations indicated.

1.4 CLOSEOUT SUBMITTALS

A. Maintenance Data: For accessories to include in maintenance manuals.

1.5 WARRANTY

A. Manufacturer's Special Warranty for Mirrors: Manufacturer agrees to repair or replace mirrors that fail in materials or workmanship within specified warranty period.

1. Warranty Period: 15 years from date of Substantial Completion.

**NISQUALLY STATE PARK
NEW FULL SERVICE PARK – PHASE 2**

PART 2 - PRODUCTS

2.1 PERFORMANCE CRITERIA

- A. Regulatory Requirements: Comply with applicable provisions in the U.S. Architectural & Transportation Barriers Compliance Board's ADA-ABA Accessibility Guidelines for Buildings and Facilities and ICC A117.1 for toilet and bath accessories designated as accessible.

2.2 OWNER-FURNISHED PRODUCTS

- A. Owner-Furnished Products: Where indicated on Drawings, Owner will furnish the following accessories for installation by Contractor:
 - 1. Toilet Tissue dispenser.
- B. Verify with Owner for specific products to ensure proper blocking and preparation for installation.

2.3 TOILET AND BATH ACCESSORIES

- A. Grab Bars (GB): Concealed mounting with snap flanges.
 - 1. Products: Subject to compliance with requirements, provide one of the following:
 - a. American Specialties, Inc.: Model No. 3800 Series.
 - b. Bobrick Washroom Equipment, Inc.: No. B-6806 Series.
 - c. Bradley Corporation: No. 812 Series.
 - d. GAMCO; a Division of Bobrick: 150S Series
 - 2. Materials: 18-8, Type 304, 0.0500 inch thick stainless steel tubing. Ends of grab bar pass through flanges and are heliarc welded to flanges to form 1 structural unit.
 - 3. Outside diameter 1-1/2 inches.
 - a. Finish: Smooth, ASTM A480 No. 4 finish (satin) on ends and slip-resistant texture in grip area.
 - 4. Concealed Mounting Flanges: 18-8, Type 304, 0.1250 inch thick stainless steel plate.
 - a. End Flanges: 2 inches by 3-1/8 inches, with 2 holes for attachment to wall.
 - b. Intermediate Flanges: 2-5/8 inches by 3-1/8 inches by 3-1/8 inches diameter.
 - 5. Snap Flange Covers: 18-8 S, Type 304, 0.031 inch thick stainless steel, satin finish. 3-1/4 inch diameter by 1/2 inch deep; snap over mounting flange to conceal mounting screws.
 - 6. Lengths: As indicated on Drawings.
 - a. GB18: 18 inch vertical.
 - b. GB36: 36 inch horizontal.
 - c. GB42: 42 inch horizontal.

**NISQUALLY STATE PARK
NEW FULL SERVICE PARK – PHASE 2**

7. Where grab bars are mounted on dissimilar adjacent surfaces that do not meet on an equal plane, modify end post lengths as required to mount grab bars plumb and true.
 8. Provide special non-slip finish on grab bars where indicated.
- B. Sanitary-Napkin Disposal Unit: Surface-mounted napkin/tampon disposal unit.
1. Product: Subject to compliance with requirements, provide one of the following:
 - a. American Specialties, Inc.: Model No. 0852.
 - b. Approved substitution.
 2. Material and Finish: 0.0312 inch thick 18-8, Type 304 stainless steel with No. 4 finish (satin), all-welded, seamless construction, with square side edges of container and cover.
 3. Container: Provide with integral finger depression for opening cover.
 4. Cover: Matches radius as container, with full-length concealed stainless steel piano hinge.
 5. Nominal Size: Nominal 8 inch wide, 9-3/4 inch high, 3-7/8 inch deep.
 6. Capacity: 1.2 gallons.
 7. Receptacle: Removable.
- C. Double Towel Bar: Concealed mounting.
1. Products: Subject to compliance with requirements, provide the following:
 - a. Grohe: Essentials Model #40802001.
 - b. Bobrick Washroom Equipment, Inc.: No. B-673 Series.
 - c. Kohler Co.: Components Double Towel Bar, Model K-78375-BN.
 - d. Moen Incorporated: Arlys Model Y5722BN.
 - e. Approved substitution.
 2. Material: Die-cast zinc alloy.
 3. Finish: Brushed nickel.
 4. Mounting: Round flanges with concealed fasteners.
 5. Length: 24 inches.
 6. Depth: 5 inches
 7. Provide manufacturer's standard mounting fasteners and stainless steel set screws.
- D. Single Towel Bar: Concealed mounting.
1. Products: Subject to compliance with requirements, provide the following:
 - a. American Specialties, Inc.: Model No. 7360-S Series.
 - b. Bobrick Washroom Equipment, Inc.: No. B-6737 Series.
 - c. Bradley Corporation: Model 9054.
 - d. Approved substitution.
 2. Material: 18-8 S, Type 304 stainless steel.
 - a. Flange and Support Arm: 0.0312 inch thick.
 - b. Concealed Wall Plate: 0.0625 inch thick.
 - c. Towel Bar: 3/4 in. square, min. 0.0312 inch thick, lockseam rolled.Finish: Satin.

**NISQUALLY STATE PARK
NEW FULL SERVICE PARK – PHASE 2**

4. Provide manufacturer's standard mounting fasteners and stainless steel set screws.
- E. Heavy-Duty Clothes Hook: Concealed mounted heavy-duty clothes hook.
1. Product: Subject to compliance with requirements, provide one of the following:
 - a. American Specialties, Inc.: Model No. 0751.
 - b. Bobrick Washroom Equipment, Inc.: No. B-2116.
 - c. Bradley Corporation: Model 9119-81.
 2. Material: 1-piece brass casting with satin nickel finish.
 3. Size: 2-3/4 diameter cover plate with nominal 3-1/4 inch total hook projection.
 4. Concealed Wall Plate: 0.105 inch thick.
 5. Force Capacity: Able to withstand 300 lb. downward pressure.
 6. Provide manufacturer's standard mounting fasteners and stainless steel set screws.
 7. Quantity: Provide 2 per toilet room and 4 per shower room.
- F. Mirror Unit (MIR): Channel frame type unit with shelf.
1. Products: Subject to compliance with requirements, provide products by one of the following:
 - a. American Specialties, Inc.: No. 0605.
 - b. Bobrick Washroom Equipment, Inc.: No. B-166 Series.
 - c. Bradley Corporation: Model 7815 Series.
 2. Back of Mirror: Provide full-size, shock absorbing, water-resistant, nonabrasive, 3/16 inch thick polyethylene padding.
 3. Frame: Type 430 stainless-steel channel, 0.0500 inch thick.
 - a. Size: 1/2 inch by 1/2 inch by 3/8 inch, with 1/4 inch return at backside.
 - b. Corners: 90 deg mitered and mechanically interlocked.
 4. Integral Shelf: 5 inch deep, 18-8, Type 304, 0.0500 inch thick stainless steel, with hemmed exposed edges.
 5. Hanging Brackets: Heavy-gage galvanized-steel brackets at top and bottom of unit for mounting on concealed wall hangers that prevents mirror from pulling away from wall.
 6. Size: 18 inch wide by 36 inch high.
- G. Shower Seat: Folding, molded plastic shower seat in "L" shape configuration.
1. Products: Subject to compliance with requirements, provide one of the following:
 - a. American Specialties, Inc.: No. 8206-L.
 - b. Bobrick Washroom Equipment, Inc.: No. B-5181, left hand.
 - c. Bradley Corporation: Model 9569 Reversible Phenolic Shower Seat.
 2. Size: Nominal 33 inch wide by 21 inch deep.
 3. Configuration: Left or right handed, as indicated on Drawings.
 4. Seat: 1/2 inch thick, solid phenolic with integral slots for water drainage, secured to frame with steel carriage bolts and acorn nuts.

**NISQUALLY STATE PARK
NEW FULL SERVICE PARK – PHASE 2**

5. Frame: 18-8, Type 304 stainless steel with No. 4 finish (satin), 0.0625 inch thick, 1-1/4 inch square tubing and 0.050 inch thick, 1 inch diameter seamless tubing.
6. Mounting Flange: 18-8, Type 304 stainless steel with No. 4 finish (satin), 3/16 inch thick, with mounting screw holes.
7. Base Plate: 18-8, Type 304 heavy-gauge stainless steel.
8. Spring: 17-7, Type-301, 0.0250 inch thick stainless steel, spot-welded to baseplate.
9. Guide Bracket: 0.050 inch thick stainless steel with No. 4 finish (satin).

H. Soap Dish:

1. Products: Subject to compliance with requirements, provide one of the following:
 - a. American Specialties, Inc.: Model No. 7404-S.
 - b. Approved substitution.
2. Size: 6-1/4 inch wide by 6-5/16 inch high by 1-7/8 inch deep.
3. Material: 1-piece seamless, 0.0312 inch thick, 18-8 S, Type 304 stainless steel with predrilled keyhole mounting holes.
4. Finish: Satin. Mounting: Recessed, with clamp or lugs appropriate for securing to wall construction indicated.

2.4 UNDERLAVATORY GUARDS

A. Underlavatory Guard: Insulating pipe covering for supply and drain piping assemblies that prevent direct contact with piping and allow service access without removing coverings.

1. Products: Subject to compliance with requirements, provide one of the following:
 - a. American Granby Inc.: HC500R Trap Wrap.
 - b. Plumberex Specialty Products, Inc.: Pro-Extreme Under-Lav Covers.
 - c. IPS Corporation: Truebro Lav Guard 2E-Z Series.
2. Material and Finish: Antimicrobial, molded-plastic.
3. Minimum wall thickness: 1/8 inch.
4. Color: White.

2.5 CORROSION TREATMENT

A. Coat exposed stainless steel surfaces with clear, hard-coat resin.

1. Products: Subject to compliance with requirements, provide one of the following:
 - a. HBI, Inc.: Nyalic.
 - b. Approved substitution.

**NISQUALLY STATE PARK
NEW FULL SERVICE PARK – PHASE 2**

2.6 MATERIALS

- A. Stainless Steel: ASTM A240 or ASTM A666, Type 304, 0.031 inch minimum nominal thickness unless otherwise indicated.
- B. Fasteners: Screws, bolts, and other devices of same material as accessory unit and tamper-and-theft resistant where exposed, and of galvanized steel where concealed unless indicated otherwise.

2.7 FABRICATION

- A. Fabricate units with tight seams and joints, and exposed edges rolled. Hang doors and access panels with full-length, continuous hinges. Equip units for concealed anchorage and with corrosion-resistant backing plates.
- B. Mirror Frame Filler:
 - 1. Where framed mirrors are mounted on walls having ceramic tile wainscots not flush with wall above, provide fillers at void between back of mirror and wall surface.
 - 2. Fabricate fillers from same material and finish as mirror frame, contoured to conceal void behind mirror at sides and top.

PART 3 - EXECUTION

3.1 INSTALLATION

- A. Install accessories according to manufacturers' written instructions, using fasteners appropriate to substrate indicated and recommended by unit manufacturer. Install units level, plumb, and firmly anchored in locations and at heights indicated.
- B. Grab Bars: Install to withstand a downward load of at least 250 lbf, when tested according to ASTM F446.
- C. Coat exposed stainless steel surfaces with corrosion treatment after assembly and installation.

3.2 ADJUSTING

- A. Adjust accessories for unencumbered, smooth operation. Replace damaged or defective items.

3.3 CLEANING

- A. Remove temporary protective coverings and strippable films as toilet accessories are installed.

END OF SECTION

**NISQUALLY STATE PARK
NEW FULL SERVICE PARK – PHASE 2**

SECTION 103500 – FLAGPOLE

PART 1 - GENERAL

1.1 SECTION INCLUDES

- A. Aluminum flagpoles.

1.2 REFERENCES

- A. Aluminum Association (AA): Aluminum Finishes.
- B. American Society for Testing and Materials (ASTM):
 - 1. ASTM B 241 - Standard Specification for Aluminum and Aluminum-Alloy Seamless Pipe and Seamless Extruded Tube.
 - 2. ASTM B 597 - Standard Practice for Heat Treatment of Aluminum Alloys.
- C. National Association of Architectural Metal Manufacturers (NAAMM): NAAMM FP 1001 - Guide Specifications for Design of Metal Flagpoles.

1.3 RELATED SECTIONS

- A. Section 033000 Cast-in-Place Concrete
- B. Section 033010 Cement Concrete Paving
- C. Section 312000 Earth Moving
- D. Section 321500 Crushed Rock Surfacing

1.4 SUBMITTALS

- A. Submit under provisions of Section 013000 Administrative Procedures.
- B. Product Data: Manufacturer's data sheets on each product to be used, including:
 - 1. Preparation instructions and recommendations.
 - 2. Storage and handling requirements and recommendations.
 - 3. Installation instructions.
- C. Shop Drawing, Metal Fabrication and Assemblies: Indicate materials, dimensions, layout, perimeter conditions, junctions with dissimilar materials, accessories, and setting details.
 - 1. Include details of foundation system.

**NISQUALLY STATE PARK
NEW FULL SERVICE PARK – PHASE 2**

- D. Submit manufacturers' catalogue cuts and manufacturers' recommended installation instructions of items for all miscellaneous Site Furnishings.
- E. Manufacturer's Certificates: Certify products meet or exceed specified requirements.
- F. Closeout Submittals: Provide manufacturer's maintenance instructions that include recommendations for periodic cleaning and maintenance of all components.

1.5 QUALITY ASSURANCE

- A. Manufacturer Qualifications: Minimum five years experience in producing site furnishings of the type specified.
- B. Installer Qualifications: All products listed in this section are to be installed by a single installer with a minimum of five years demonstrated experience in installing products of the same type and scope as specified.
- C. Single Source Responsibility:
 - 1. Obtain each flagpole as a complete unit from American Flagpole & Flag Co., including fittings, accessories, bases, and anchorage devices.
- D. Mock-Up: Provide a mock-up for evaluation of surface preparation techniques and application workmanship.
 - 1. Locate mock-up in location as directed by the Engineer.
 - 2. Do not proceed with remaining work until workmanship are approved by Landscape Architect.
 - 3. Mock-up area may become part of finished work.

1.6 DELIVERY, STORAGE, AND HANDLING

- A. Deliver and store products in manufacturer's unopened packaging until ready for installation.
- B. Spiral wrap flagpoles with heavy paper and enclose in a hard fiber tube or other protective container.
- C. Keep flagpole and accessories covered and dry to prevent soiling or damage.
- D. Handle with protective gloves to prevent unwanted distortion.

1.7 PROJECT CONDITIONS

- A. Structural Performance: Provide flagpole assemblies, including anchorages and supports, capable of withstanding the effects of wind loads, determined according to NAAMM FP 1001 for specified ground speed.

**NISQUALLY STATE PARK
NEW FULL SERVICE PARK – PHASE 2**

1.8 PROTECTION

- A. Protect all work installed under this section from any cause whatsoever, including subsequent construction activities and vandalism until final acceptance.

PART 2 - PRODUCTS

2.1 MANUFACTURERS

- A. Acceptable Manufacturer:

- 1. American Flagpole & Flag Co.; Lake Elmo, MN 55042. ASD. Toll Free Tel: (800) 426-6235. Fax (651) 777-1925. Email: info@aflag.com . Web: www.aflag.com.

2.2 FLAGPOLES

- A. Aluminum Flagpole Construction

- 1. Fabricate from seamless, extruded tubing complying with ASTM B 221, alloy 6063-T6, having a tensile strength not less than 30,000 psi with yield point of 25000 psi. Heat treated after fabrication to comply with ASTM B 597, temper T-6

- B. Estate Series: Model EAF20030125

- 1. External Halyard, ground set, cone-tapered, aluminum flagpole. Including ground sleeve, external halyard system, rope, ball to match flagpole base diameter, cleat, stationary truck, and two nylon snap hooks. Finish exposed metal surfaces to match flagpole.

- a. Exposed Height: 20ft
- b. Overall Length: 22ft
- c. Diameter: 3” base and 2” top
- d. Wall thickness: .125”
- e. Wind Speed: 85 MPH flagged, 123 MPH un-flagged
- f. Mounting Device: PVC Ground Sleeve

- C. Finish:

- 1. 1. Directional Sanded Satin Finish: Fine, directional, medium satin polish; buff complying with AA-M20; and seal aluminum surfaces with clear, hard-coat wax
 - a. Satin Brushed Aluminum finish

PART 3 - EXECUTION

3.1 EXAMINATION

- A. Do not begin installation until final grades and elevations have been established.

**NISQUALLY STATE PARK
NEW FULL SERVICE PARK – PHASE 2**

3.2 GENERAL

- A. Stake alignment and location for Owner approval prior to installation.
- B. Install rigid, plumb and true to lines and levels shown. Verify that all elements called for in this Section “fit” according to the drawings and existing site features.
- C. Assemble and install all equipment specified by name/manufacture as per approved manufacture’s printed instructions/recommendations. Provide Owner with all printed instructions/recommendations.

3.3 INSTALLATION

- A. Install flagpole where shown on drawings and in accordance with manufacturer’s written instructions.
 - 1. Flagpole shall be plumbed with ¼” for every 10 feet of pole height.

3.4 CLEANING

- A. Clean up debris and unused or excess material and remove from the site. Completely remove all concrete, mud, dirt and other substances from Work.
- B. Touch-up, repair or replace damaged products before Substantial Completion.

END OF SECTION

**NISQUALLY STATE PARK
NEW FULL SERVICE PARK – PHASE 2**

SECTION 104413 – FIRE PROTECTION CABINETS

PART 1 - GENERAL

1.1 SUMMARY

A. Section Includes:

1. Fire-protection cabinets for portable fire extinguisher.

1.2 ADMINISTRATIVE REQUIREMENTS

A. Coordination:

1. Coordinate size of fire protection cabinets to ensure that type and capacity of fire extinguishers indicated are accommodated.
2. Coordinate sizes and locations of fire protection cabinets with wall depths.

B. Preinstallation Meetings: Conduct meeting at Project.

1. Review methods and procedures related to fire protection cabinets, including schedules and coordination requirements.

1.3 ACTION SUBMITTALS

A. Product Data: For each type of product.

1. Show door hardware, cabinet type, trim style, and panel style. Include roughing-in dimensions and details showing recessed-, semi-recessed-, or surface-mounting method and relationships of box and trim to surrounding construction.

B. Samples for Verification: 6 by 6 inch square Samples of each type of exposed finish required.

C. Product Schedule:

1. For fire-protection cabinets. Indicate whether recessed, semi-recessed, or surface mounted.
2. Coordinate final fire-protection cabinet schedule with fire-extinguisher schedule to ensure proper fit and function.
3. Use same designations indicated on Drawings if indicated.

1.4 CLOSEOUT SUBMITTALS

A. Maintenance Data: For fire-protection cabinets to include in maintenance manuals.

**NISQUALLY STATE PARK
NEW FULL SERVICE PARK – PHASE 2**

PART 2 - PRODUCTS

2.1 MANUFACTURERS

- A. Source Limitations: Obtain fire-protection cabinets, fire extinguishers, and accessories from single source from single manufacturer.

2.2 FIRE-PROTECTION CABINETS

- A. Cabinets, General: Provide fire protection cabinets as suitable for fire extinguisher.
- B. Cabinet Type-FEC-1: Suitable for fire extinguisher. Semi-recessed cabinet with 1-piece combination, square-edge trim and perimeter door frame overlapping surrounding wall surface with exposed trim face and wall return at outer edge (backbend).

1. Products: Subject to compliance with requirements, provide one of the following:

- a. Babcock-Davis: Model BFC-7300 Series.
- b. J. L. Industries, Inc.: Clear Vu Series, Model 1517.
- c. Larsen's Manufacturing Company: Cameo Series C 2409-6R.
- d. Nystrom, Inc. Model FC-7300 Series.
- e. Potter Roemer Fire Pro, Morris Group Int'l: Loma Series, Model 7322.
- f. Approved substitution.

2. Rolled-Edge Trim: 2-1/2 to 3 inch backbend depth.
3. Projection: Nominal 2-1/2 inches.
4. Nominal Cabinet Size: Verify rough openings once product has been selected.

- a. Height: 24 inches.
- b. Width: 9 to 10-1/2 inches.
- c. Depth: 4 inches.

5. Cabinet Construction: Non-rated.
6. Cabinet Material: Cold-rolled steel sheet.
7. Cabinet Trim Material: Same material and finish as door.
8. Door Material: Steel sheet.
9. Door Style: Full acrylic bubble with frame.
10. Door Glazing: Molded acrylic bubble.
11. Acrylic Sheet Color: Clear, transparent.
12. Acrylic Bubble Color: Clear, transparent.
13. Acrylic Bubble Projection: Nominal 2-1/2 inches.
14. Provide manufacturer's standard fire extinguisher mounting bracket.

- C. Door Hardware: Manufacturer's standard door-operating hardware of proper type for cabinet type, trim style, and door material and style indicated.

1. Provide manufacturer's recessed door pull where required by ADA Accessibility Guidelines.
2. Provide continuous hinge, of same material and finish as trim, permitting door to open 180 degrees.

**NISQUALLY STATE PARK
NEW FULL SERVICE PARK – PHASE 2**

D. Accessories:

1. Mounting Bracket: Manufacturer's standard steel, designed to secure fire extinguisher to fire-protection cabinet, of sizes required for types and capacities of fire extinguishers indicated, with plated or baked-enamel finish.
2. Non-Break Glass Cabinet Lock: Safety-type cam lock that allows door to be opened during emergency by pulling sharply on door handle.
 - a. Products: Subject to compliance with requirements, provide one of the following:
 - 1) JL Industries, Inc.; a division of Activar Construction Products Group: Saf-T-Lok.
 - 2) Larsen's Manufacturing Company: Larsen-Loc.
 - 3) Potter Roemer LLC. Break Rite.
 - 4) Approved substitution.
 - b. Above door lock, provide manufacturer's factory applied lettering reads: "IN CASE OF FIRE ONLY – PULL FIRMLY ON HANDLE".
3. Identification: Lettering complying with authorities having jurisdiction for letter style, size, spacing, and location. Locate as indicated.
 - a. Identify fire extinguisher in fire-protection cabinet with the words "FIRE EXTINGUISHER."
 - 1) Application Process: Pressure-sensitive vinyl letters applied to cabinet glazing.
 - 2) Lettering Color: Black.
 - 3) Orientation: Vertical.

E. Materials:

1. Cold-Rolled Steel Sheet: ASTM A1008, Commercial Steel (CS), Type B.
 - a. Finish: Baked enamel or powder coat.
 - b. Color: Manufacturer's standard white.
2. Stainless Steel: ASTM A240 or ASTM A666, Type 304.
 - a. Finish: ASTM A480 No. 4 directional satin finish,
3. Tempered Float Glass: ASTM C1048, Kind FT, Condition A, Type I, Quality q3, 3 mm thick, Class 1 (clear).

2.3 FABRICATION

- A. Fire-Protection Cabinets: Provide manufacturer's standard box (tub) with trim, frame, door, and hardware to suit cabinet type, trim style, and door style indicated.
1. Weld joints and grind smooth.
 2. Miter corners and grind smooth.

**NISQUALLY STATE PARK
NEW FULL SERVICE PARK – PHASE 2**

3. Provide factory-drilled mounting holes.
 4. Prepare doors and frames to receive locks.
 5. Install door locks at factory.
- B. Cabinet Doors: Fabricate doors according to manufacturer's standards, from materials indicated and coordinated with cabinet types and trim styles.
1. Fabricate door frames with minimum 1/2 inch thick tubular stiles and rails and hollow-metal design.
 2. Fabricate door frames of one-piece construction with edges flanged.
 3. Miter and weld perimeter door frames and grind smooth.
- C. Cabinet Trim: Fabricate cabinet trim in 1 piece with corners mitered, welded, and ground smooth.

2.4 GENERAL FINISH REQUIREMENTS

- A. Comply with NAAMM's AMP 500, "Metal Finishes Manual for Architectural and Metal Products," for recommendations for applying and designating finishes.
- B. Protect mechanical finishes on exposed surfaces of fire-protection cabinets from damage by applying a strippable, temporary protective covering before shipping.
- C. Finish fire-protection cabinets after assembly.
- D. Appearance of Finished Work: Noticeable variations in same piece are unacceptable. Variations in appearance of adjoining components are acceptable if they are within range of approved Samples and are assembled or installed to minimize contrast.

PART 3 - EXECUTION

3.1 EXAMINATION

- A. Examine walls and partitions for suitable framing depth and blocking where semi-recessed cabinets will be installed.
- B. Proceed with installation only after unsatisfactory conditions have been corrected.

3.2 PREPARATION

- A. Prepare recesses for recessed and semi-recessed fire-protection cabinets as required by type and size of cabinet and trim style.

**NISQUALLY STATE PARK
NEW FULL SERVICE PARK – PHASE 2**

3.3 INSTALLATION

- A. Install fire-protection cabinets in locations and at mounting heights indicated or, if not indicated, at height indicated below:
 - 1. Fire-Protection Cabinet Mounting Height: 42 inches above finished floor to top of fire extinguisher.
- B. Fire-Protection Cabinets: Fasten cabinets to structure, square and plumb.
 - 1. Unless otherwise indicated, provide semi-recessed fire-protection cabinets.
 - 2. Provide inside latch and lock for break-glass panels.
 - 3. Fasten mounting brackets to inside surface of fire-protection cabinets, square and plumb.
- C. Identification:
 - 1. Apply vinyl lettering at locations indicated.

3.4 REPAIR

- A. Touch up marred finishes, or replace fire-protection cabinets that cannot be restored to factory-finished appearance. Use only materials and procedures recommended or furnished by fire-protection cabinet and mounting bracket manufacturers.
- B. Replace fire-protection cabinets that have been damaged or have deteriorated beyond successful repair by finish touchup or similar minor repair procedures.

3.5 ADJUSTING

- A. Remove temporary protective coverings and strippable films, if any, as fire-protection cabinets are installed unless otherwise indicated in manufacturer's written installation instructions.
- B. Adjust fire-protection cabinet doors to operate easily without binding. Verify that integral locking devices operate properly.

3.6 CLEANING

- A. On completion of fire-protection cabinet installation, clean interior and exterior surfaces as recommended by manufacturer.

END OF SECTION

**NISQUALLY STATE PARK
NEW FULL SERVICE PARK – PHASE 2**

SECTION 104416 – FIRE EXTINGUISHERS

PART 1 - GENERAL

1.1 SUMMARY

A. Section Includes:

1. Portable, hand-carried fire extinguishers and mounting brackets for fire extinguishers.

1.2 ADMINISTRATIVE REQUIREMENTS

A. Coordination:

1. Coordinate type and capacity of fire extinguishers with fire protection cabinets to ensure fit and function.

B. Preinstallation Meeting: Conduct meeting at Project site.

1. Review methods and procedures related to fire extinguishers including schedules and coordination requirements.

1.3 ACTION SUBMITTALS

A. Product Data: For each type of product. Include rating and classification, material descriptions, dimensions of individual components and profiles, and finishes for fire extinguisher and mounting brackets.

B. Product Schedule: For fire extinguishers.

1. Coordinate final fire-extinguisher schedule with fire-protection cabinet schedule to ensure proper fit and function.
2. Use same designations indicated on Drawings if indicated.

1.4 INFORMATIONAL SUBMITTALS

A. Warranty: Sample of special warranty.

1.5 CLOSEOUT SUBMITTALS

A. Operation and Maintenance Data: For fire extinguishers to include in maintenance manuals.

**NISQUALLY STATE PARK
NEW FULL SERVICE PARK – PHASE 2**

1.6 WARRANTY

- A. Special Warranty: Manufacturer's standard form in which manufacturer agrees to repair or replace fire extinguishers that fail in materials or workmanship within specified warranty period.
 - 1. Failures include the following:
 - a. Failure of hydrostatic test according to NFPA 10.
 - b. Faulty operation of valves or release levers.
 - 2. Warranty Period: 6 years from date of Substantial Completion.

PART 2 - PRODUCTS

2.1 MANUFACTURERS

- A. Source Limitations: Obtain fire extinguishers, fire-protection cabinets, and accessories, from single source from single manufacturer.

2.2 PERFORMANCE CRITERIA

- A. NFPA Compliance: Fabricate and label fire extinguishers to comply with NFPA 10, "Portable Fire Extinguishers."
- B. Fire Extinguishers: Listed and labeled for type, rating, and classification by an independent testing agency acceptable to authorities having jurisdiction.

2.3 PORTABLE, HAND-CARRIED FIRE EXTINGUISHERS

- A. Fire Extinguishers, General: Type, size, and capacity for each fire-protection cabinet and mounting bracket indicated.
 - 1. Valves: Manufacturer's standard.
 - 2. Handles and Levers: Manufacturer's standard stainless steel.
 - 3. Instruction Labels: Include pictorial marking system complying with NFPA 10, Appendix B, and bar coding for documenting fire-extinguisher location, inspections, maintenance, and recharging.
- B. Multipurpose Dry-Chemical Type in Steel Container (FE-1): UL-rated, with monoammonium phosphate-based dry chemical in enameled-steel container.
 - 1. Products: Subject to compliance with requirements, provide one of the following:
 - a. Amerex Corporation: Model B456.
 - b. Babcock-Davis: BEX-3010.
 - c. JL Industries, Inc.: Model Cosmic 10E.
 - d. Kidde Residential and Commercial Division: Model ProPlus 10 MP.

**NISQUALLY STATE PARK
NEW FULL SERVICE PARK – PHASE 2**

- e. Larsen's Manufacturing Company: MP Series MP10.
 - f. Nystrom, Inc. Model EX-3010.
 - g. Potter Roemer LLC. Model Number 3010.
 - h. Approved substitution.
- 2. Nominal Capacity: 10 lb.
 - 3. UL Rating: 4-A:80-B:C, 10-lb.
 - 4. Finish Color: Red.
 - 5. Locations:
 - a. Interior common areas.
 - b. Corridors.
 - c. Mechanical spaces.
 - d. Parking garages and ramps.
 - e. Unconditioned areas where indicated.
 - f. Other conditioned areas where FE-1 are not indicated but required by local fire official.

2.4 MOUNTING BRACKETS

- A. Mounting Brackets: Manufacturer's standard galvanized steel, designed to secure fire extinguisher to wall or structure, of sizes required for types and capacities of fire extinguishers indicated, with plated or red baked-enamel finish.
 - 1. Source Limitations: Obtain mounting brackets and fire extinguishers from single source from single manufacturer.
- B. Identification: Lettering complying with authorities having jurisdiction for letter style, size, spacing, and location. Locate as indicated by Architect.
 - 1. Identify bracket-mounted fire extinguishers with the words "FIRE EXTINGUISHER" in red letter decals applied to mounting surface.
 - a. Orientation: Vertical.

PART 3 - EXECUTION

3.1 EXAMINATION

- A. Examine fire extinguishers for proper charging and tagging.
 - 1. Remove and replace damaged, defective, or undercharged fire extinguishers.
- B. Proceed with installation only after unsatisfactory conditions have been corrected.

**NISQUALLY STATE PARK
NEW FULL SERVICE PARK – PHASE 2**

3.2 INSTALLATION

- A. Install fire extinguishers and mounting brackets in locations indicated and in compliance with requirements of AHJ.
- B. Mounting Brackets: Fasten mounting brackets to surfaces, square and plumb, at locations indicated.
 - 1. Mounting Bracket Height: Install brackets to ensure top of fire extinguisher is 42 inches above finished floor.

END OF SECTION

**NISQUALLY STATE PARK
NEW FULL SERVICE PARK – PHASE 2**

SECTION 105123 – PLASTIC-LAMINATE-CLAD LOCKERS

PART 1 - GENERAL

1.1 SUMMARY

A. Section Includes:

1. Plastic-laminate-clad wood lockers.
2. Locker benches.

1.2 ADMINISTRATIVE REQUIREMENTS

A. Coordination:

1. Coordinate with Owner for type of lockers selected for installation.
2. Coordinate sizes and locations of support bases for plastic-laminate-clad wood lockers.
 - a. Requirements are specified in Section 061000 – Rough Carpentry.
3. Coordinate sizes and locations of framing, blocking, furring, reinforcements, and other related units of Work specified in other Sections to ensure that lockers can be supported and installed as indicated.

PART 2 - PRODUCTS

2.1 PERFORMANCE CRITERIA

- A. Regulatory Requirements:** For lockers and locker benches indicated to be accessible, comply with applicable provisions in USDOJ's "2010 ADA Standards for Accessible Design" and ICC A117.1.

2.2 PLASTIC-LAMINATE-CLAD WOOD LOCKERS

A. Basis-of-Design Product: Subject to compliance with requirements, provide the following:

1. Hamilton Casework Solutions: MCLZ Z Locker with 2 Doors.
2. Approved substitution.

B. Construction Style: Flush overlay unless indicated otherwise.

C. Final Assembly: Manufacturer's standard factory assembly.

**NISQUALLY STATE PARK
NEW FULL SERVICE PARK – PHASE 2**

- D. Locker Body: Fabricated from particleboard core panels covered on both sides with thermoset decorative overlay.
 - 1. Side Panels: Manufacturer's standard 3/4 or 5/8 inch thick.
 - 2. Back Panel: Manufacturer's standard 1/2 or 3/8 inch thick.
 - 3. Top Panel: Manufacturer's standard 3/4 or 5/8 inch thick.
 - 4. Bottom Panel: Manufacturer's standard 3/4 or 5/8 inch thick.
 - 5. Exposed Panel Edges: Manufacturer's standard thermoset decorative overlay or high-pressure decorative laminate to match panel.
- E. Plastic-Laminate-Clad Wood Doors: High-pressure decorative laminate, Grade VGS, over both sides of particleboard core.
 - 1. Thickness: Manufacturer's standard 3/4 or 5/8 inch thick.
 - 2. Panel Edges: Minimum 1.5 mm thick PVC to closely match door finish.
- F. End Panels: Match style, material, construction, and finish of plastic-laminate-clad wood doors.
- G. Shelves: Fabricated from particleboard-core panels covered on both sides with thermoset decorative overlay; fixed unless otherwise indicated.
 - 1. Thickness: 5/8 inch.
 - 2. Exposed Edges: Minimum 1.5 mm thick PVC to closely match shelf finish.
- H. Corners and Filler Panels: 3/4 inch thick panels. Match style, material, construction, and finish of plastic-laminate-clad wood doors.
- I. Continuous Finish Base: Plastic-laminate-clad, 3/4 inch thick panel that matches door faces; fabricated in lengths as long as practical to enclose base and base ends of lockers.
- J. Plastic-Laminate Colors, Patterns, and Finishes:
 - 1. As selected by Architect from plastic-laminate manufacturer's full range of colors and patterns.

2.3 MATERIALS

- A. Composite Wood: Provide materials that comply with requirements of referenced quality standard for each type of woodwork and quality grade specified unless otherwise indicated.
 - 1. Thermoset Decorative Panels: Particleboard or medium-density fiberboard finished with thermally fused, melamine-impregnated decorative paper and complying with requirements of ISO 4586-3, Grade VGL, for Test Methods 3.3, 3.4, 3.6, 3.8, and 3.10.
 - 2. Particleboard: ANSI A208.1, Grade M-2.

**NISQUALLY STATE PARK
NEW FULL SERVICE PARK – PHASE 2**

- B. High-Pressure Decorative Laminate: ISO 4586-3, grades as follows:
 - 1. Horizontal Surfaces: Grade HGS.
 - 2. Postformed Surfaces: Grade HGP.
 - 3. Vertical Surfaces: Grade VGS.
- C. Adhesive for Bonding Plastic Laminate: Unpigmented contact cement or selected by fabricator to comply with requirements.
 - 1. Adhesive for Bonding Edges: Hot-melt adhesive or adhesive specified above for faces.
- D. Furring, Blocking, Shims, and Hanging Strips: Softwood or hardwood lumber, kiln dried to less than 15 percent moisture content.
- E. Anchors: Material, type, size, and finish as required for each substrate for secure anchorage.
 - 1. Provide metal expansion sleeves or expansion bolts for post-installed anchors.
 - 2. Use nonferrous-metal or hot-dip galvanized anchors and inserts at inside face of exterior walls and at floors.

2.4 **HARDWARE**

- A. Recessed Door Handle and Latch: Stainless-steel cup with integral door pull, recessed so locking device does not protrude beyond face of door; pry and vandal resistant.
 - 1. Single-Point Latching: Nonmoving latch hook designed to engage bolt of built-in combination or cylinder lock.
 - a. Latch Hook: Equip each door with 1 latch hook, fabricated from 0.105 inch nominal-thickness steel sheet; welded midway up full-height door strike; with resilient silencer.
- B. Built-in Combination Lock: Key-controlled, 3-number dialing combination locks; capable of at least 5 combination changes made automatically with a control key.
 - 1. Bolt Operation: Manufacturer's standard locking deadbolt or spring bolt.
- C. Frameless Hinges (European Type): Fully concealed[, self-closing], nickel-plated steel, with not less than 125 degrees of opening.
 - 1. Provide 2 hinges for doors 36 inches high and less.
 - 2. Provide 3 hinges for doors more than 36 inches high.
- D. Accessible Handle: Metal, fixed, graspable lever handle and rose trim; surface mounted.
- E. Hooks: Manufacturer's standard, ball-pointed aluminum or stainless steel.

**NISQUALLY STATE PARK
NEW FULL SERVICE PARK – PHASE 2**

1. Attach hooks with at least 2 fasteners.
 2. Provide 1 double-prong ceiling hook for each compartment of single-tier and double-tier lockers.
- F. Coat Rods: Minimum 3/4 inch diameter nickel-plated steel;
1. Provide coat rods as indicated on Drawings.
 2. Provide coat rod for each compartment of single-tier and double-tier lockers.
- G. Exposed Hardware Finish: Unless otherwise indicated, provide finish that complies with BHMA A156.18 for BHMA finish number indicated.
1. Satin Chromium Plated: BHMA 626 for brass or bronze base; BHMA 652 for steel base.

2.5 LOCKER BENCHES

- A. Pedestal-Leg Locker Benches, ADA: Bench top supported by metal pedestal legs.
1. Pedestal Legs: 4 legs.
 2. Bench Tops: 1-1/4 inches deep; fabricated as follows:
 - a. Butcher Block Top: Solid laminated hardwood.
 - b. Width: 20 inches.
 - c. Length: 42 inches.
 - d. Finish and Color: As selected by Architect from bench manufacturer's standard finishes.
- B. Bench Pedestals: Provide no fewer than 2 pedestals for each bench, uniformly spaced not more than 72 inches apart. For ADA benches, each pedestal consists of 2 legs welded to single base plates.
1. Legs: 3 inch diameter aluminum tubing.
 2. Bases: 1/4 inch thick aluminum plate, 1 plate welded to each end of legs.
 3. ADA Bench Base Size: 8-1/2 in. long by 4-1/2 in. wide, with 2 bolt holes.
 4. Finish and Color: Bench manufacturer's black powder coat finish.

2.6 ACCESSORIES

- A. Number Identification Plates: 1-1/4 to 1-1/2 inch rectangular [oval] [square] [diameter], etched, embossed, or stamped, metal plates with black numbers and letters at least 1/2 inch high.
1. Identify lockers as indicated on Drawings.

**NISQUALLY STATE PARK
NEW FULL SERVICE PARK – PHASE 2**

2.7 FABRICATION

- A. Fabricate each locker with shelves, an individual door and frame, an individual top, a bottom, and a back, and with common intermediate uprights separating compartments.
 - 1. Fabricate lockers to dimensions, profiles, and details indicated.
- B. Fabricate lockers square, rigid, without warp, and with finished faces flat and free of dents, scratches, and chips. Accurately factory machine components for attachments. Make joints tight and true.
 - 1. Fabricate lockers using manufacturer's standard construction, with joints made with dowels, dados, or rabbets.
 - a. Dado side panels to receive shelving except where indicated to be adjustable.
- C. Accessible Lockers: Fabricate as follows:
 - 1. Locate bottom shelf no lower than 15 inches above floor.
 - 2. Where hooks, coat rods, or additional shelves are provided, locate no higher than 48 inches above the floor.
- D. Venting: Fabricate lockers with not less than 1/2 inch space between top and bottom of doors and locker assemblies.
- E. Complete fabrication, including assembly, finishing, and hardware application, to maximum extent possible, before shipment to Project site.
 - 1. Disassemble components only as necessary for shipment and installation.
 - 2. Where necessary for fitting at site, provide ample allowance for scribing, trimming, and fitting.
 - 3. Use only manufacturer's nuts, bolts, screws, and other devices for assembly.
- F. Shop cut openings, to maximum extent possible, to receive hardware[, electrical Work,] and similar items.
 - 1. Locate openings accurately and use templates or roughing-in diagrams to produce accurately sized and shaped openings.
 - 2. Sand edges of cutouts to remove splinters and burrs.
- G. Attach PVC edging to panels by thermally fusing edging to panels after panel fabrication.

**NISQUALLY STATE PARK
NEW FULL SERVICE PARK – PHASE 2**

PART 3 - EXECUTION

3.1 EXAMINATION

- A. Examine walls and floors or support bases, with Installer present, for compliance with requirements for installation tolerances and other conditions affecting performance of Work.
- B. Verify that furring is attached to concrete and masonry walls that are to receive lockers.
- C. Proceed with installation only after unsatisfactory conditions have been corrected.

3.2 PREPARATION

- A. Condition lockers to average prevailing humidity conditions in installation areas before installation.
- B. Before installing lockers, examine factory-fabricated Work for completeness and complete Work as required, including removal of packing.

3.3 INSTALLATION

- A. Install required support base.
- B. Install lockers level, plumb, and true; use concealed shims.
- C. Connect groups of lockers together with manufacturer's standard fasteners, through predrilled holes, with no exposed fasteners on face frames. Fit lockers accurately together to form flush, tight, hairline joints.
- D. Install lockers without distortion so doors and drawers fit openings properly and are accurately aligned. Adjust hardware to center doors and drawers in openings, providing unencumbered operation. Complete installation of hardware and accessory items as indicated.
 - 1. Installation Tolerance: No more than 1/8 inch in 96 inch sag, bow, or other variation from a straight line. Shim as required with concealed shims.
- E. Locker Anchorage:
 - 1. Fasten lockers through back, near top and bottom, at ends with No. 8 flush-head wood screws sized for 1-inch penetration into wood framing, blocking, or furring and spaced not more than 16 inches on center.
- F. Scribe and cut corner and filler panels to fit adjoining Work using fasteners concealed where practical. Repair damaged finish at cuts.
- G. Attach sloping-top units to lockers, with end panels covering exposed ends.
- H. Install number identification plates after lockers are in place.

**NISQUALLY STATE PARK
NEW FULL SERVICE PARK – PHASE 2**

1. Attach number identification plate on each locker door, near top, centered, with at least 2 screws with finish matching plate.

I. Fixed Benches: Securely fasten top plates of pedestals to undersides of bench tops, and anchor base plates to floor where indicated on Drawings.

3.4 ADJUSTING

A. Clean, lubricate, and adjust hardware. Adjust doors to operate easily without binding.

3.5 PROTECTION

A. Protect lockers from damage, abuse, dust, dirt, stain, or paint. Do not permit use during construction.

B. Touch up marred finishes, or replace lockers that cannot be restored to factory-finished appearance. Use only materials and procedures recommended or furnished by locker manufacturer.

END OF SECTION

**NISQUALLY STATE PARK
NEW FULL SERVICE PARK – PHASE 2**

SECTION 113013 – RESIDENTIAL APPLIANCES

PART 1 - GENERAL

1.1 SUMMARY

- A. Section Includes:
1. Cooking appliances.
 2. Refrigeration appliances.
 3. Cleaning appliances.

1.2 ADMINISTRATIVE REQUIREMENTS

- A. Coordination:
1. Coordinate appliance locations with other Work to prevent interference with clearances required for access by people with disabilities, and for proper installation, adjustment, operation, cleaning, and servicing of appliances.
- B. Preinstallation Meeting: Conduct meeting at Project site.

1.3 ACTION SUBMITTALS

- A. Product Data:
1. Cooking appliances.
 2. Kitchen exhaust ventilation.
 3. Refrigeration appliances.
 4. Cleaning appliances.
- B. Product Data Submittals: For each type of product.
1. Include installation details, material descriptions, dimensions of individual components, and finishes for each appliance.
 2. Include rated capacities, operating characteristics, electrical characteristics, and furnished accessories.
- C. Samples: For each exposed product and for each color and texture specified, in manufacturer's standard size.
- D. Product Schedule: For appliances. Use same designations indicated on Drawings.

**NISQUALLY STATE PARK
NEW FULL SERVICE PARK – PHASE 2**

1.4 INFORMATIONAL SUBMITTALS

- A. Qualification Data: For manufacturer.
- B. Product Certificates: For each type of appliance.
- C. Sample Warranties: For manufacturers' special warranties.

1.5 CLOSEOUT SUBMITTALS

- A. Operation and Maintenance Data: For each residential appliance to include in operation and maintenance manuals.

1.6 QUALITY ASSURANCE

- A. Manufacturer Qualifications: Maintains, within 100 miles of Project site, a service center capable of providing training, parts, and emergency maintenance repairs.

1.7 WARRANTY

- A. Special Warranties: Manufacturer agrees to repair or replace residential appliances or components that fail in materials or workmanship within specified warranty period except as qualified below.
- B. Electric Range: Full warranty, including parts and labor, for on-site service on surface-burner elements.
 - 1. Warranty Period: 1 year from date of Substantial Completion.
- C. Microwave Oven: Full warranty, including parts and labor, for on-site service on magnetron tube.
 - 1. Warranty Period: 1 year from date of Substantial Completion.
- D. Refrigerator, Sealed System: Full warranty, including parts and labor, for on-site service on product.
 - 1. Warranty Period for Sealed Refrigeration System: 5 years from date of Substantial Completion.
 - 2. Warranty Period for Other Components: 3 years from date of Substantial Completion.
 - 3. Warranty Period for Hydrocarbon Compressor: 2 years for parts for compressor defects only in addition to 5 year sealed refrigeration system.
- E. Ice maker: Full warranty including parts and labor for on-site service on product.
 - 1. Warranty Period: 2 years from date of Substantial Completion.
- F. Clothes Washer: Full warranty, including parts and labor, for on-site service on product.
 - 1. Warranty Period: 1 year from date of Substantial Completion.

**NISQUALLY STATE PARK
NEW FULL SERVICE PARK – PHASE 2**

G. Clothes Dryer: Full warranty including parts and labor for on-site service on product.

1. Warranty Period: 1 year from date of Substantial Completion.

PART 2 - PRODUCTS

2.1 MANUFACTURERS

A. Source Limitations: Obtain residential appliances from single source and each type of residential appliance from single manufacturer, unless indicated otherwise.

2.2 PERFORMANCE CRITERIA

A. Electrical Appliances: Listed and labeled as defined in NFPA 70, by a qualified testing agency, and marked for intended location and application.

B. Accessibility: Where residential appliances are indicated to comply with accessibility requirements, comply with applicable provisions in DOJ's 2010 ADA Standards for Accessible Design and ICC A117.1.

2.3 COOKING APPLIANCES

A. Electric Range: Freestanding range with 1 oven and complying with AHAM ER-1.

1. Basis-of-Design Product: Subject to compliance with requirements, provide the following:

- a. GE Appliances; a Haier Company: Model #JB480SMSS.
- b. Approved substitution:

2. Manufacturers: Subject to compliance with requirements, provide products by one of the following:

- a. Amana; Whirlpool Corporation.
- b. GE Appliances; a Haier Company.
- c. Kenmore; Transformco SR Brands LLC.
- d. Maytag; Whirlpool Corporation.
- e. Whirlpool Corporation.
- f. Approved substitution.

3. Width: 30 inches.

4. Electric Burner Elements: 4.

- a. Radiant Type: Two 1,500 W and two 2,000 W.
- b. Controls: Digital panel controls, located on front.

**NISQUALLY STATE PARK
NEW FULL SERVICE PARK – PHASE 2**

5. Oven Features:
 - a. Capacity: 5.0 cu. ft.
 - b. Operation: Baking and pyrolytic self-cleaning or catalytic continuous cleaning.
 - c. Broiler: Located in top of oven.
 - d. Oven Door(s): Counterbalanced, removable, with observation window and full-width handle.
 - e. Electric Power Rating:
 - 1) Oven(s): 2,585 W.
 - 2) Broiler: 3,410 W.
 - f. Rotary-dial controls on front panel.
6. Anti-Tip Device: Manufacturer's standard.
7. Electric Power Supply: 240 V, 60 Hz, 40 A.
8. Material: Stainless steel with ceramic-glass cooktop.

B. Microwave Oven:

1. Basis-of-Design Product: Subject to compliance with requirements, provide the following:
 - a. GE Appliances; a Haier Company: Model #JVM6175YKFS.
 - b. Approved substitution:
2. Mounting: Undercabinet.
3. Type: Conventional.
4. Dimensions:
 - a. Width: 29-7/8 inches.
 - b. Depth: 15-9/16 inches.
 - c. Height: 16-5/16 inches.
5. Capacity: 1.7 cu. ft.
6. Oven Door: Door with observation window and pull handle.
7. Exhaust Fan: 2-speed fan, vented to outside and with 300 cfm capacity.
8. Microwave Power Rating: 1,000 W.
9. Electric Power Supply: 120 V, 60 Hz, 1 phase, 15 A.
10. Controls: Digital panel controls and timer display.
11. Other Features: Turntable and lock-out feature.
12. Material: Stainless steel.

2.4 REFRIGERATOR/FREEZERS

A. Refrigeration Equipment: Refrigerators.

1. Basis-of-Design Product: Subject to compliance with requirements, provide the following:
 - a. True Manufacturing Co., Inc.: Model T-19-HC.
 - b. Approved substitution:

**NISQUALLY STATE PARK
NEW FULL SERVICE PARK – PHASE 2**

2. Description: Reach-in type.
 - a. Exterior Finish: Stainless steel.
 - b. Interior Finish: Clear coated aluminum.
 - c. Doors: Full length.
 - d. Accessories:
 - 1) Casters.
 - 2) Re-hinging feature for doors.
 - 3) PVC-Coated Wire Shelves: 3.
 - e. Electrical Service: Equip unit with plug and cord for service indicated on Drawings.

2.5 ICEMAKERS

- A. Icemaker: ADA-compliant, undercounter icemaker.

1. Basis-of-Design Product: Subject to compliance with requirements, provide the following:
 - a. Perlick Corporation: Model H50IMS-ADL.
 - b. Approved substitution:
2. Type: Undercounter.
3. Dimensions: 14-7/8 inches wide, 22-9/16 inches deep, 31-1/2 inches high.
4. Ice Capacity:
 - a. Production: 51 lb per day.
 - b. Storage: 22 lb.
5. Features:
 - a. Door Configuration: Overlay, hinged on left.
 - b. Automatic shutoff.
 - c. Defrost drain.
6. Front Panel: Stainless steel.
7. Appliance Color/Finish: Stainless steel.

2.6 CLOTHES WASHERS AND DRYERS

- A. Clothes Washer, Standard: Complying with AHAM HLW-1.

1. Basis-of-Design Product: Subject to compliance with requirements, provide the following:
 - a. GE Appliances; a Haier Company: Model #GTW500ASNWS.
 - b. Approved substitution:
2. Type: Freestanding, top-loading unit.

**NISQUALLY STATE PARK
NEW FULL SERVICE PARK – PHASE 2**

3. Dimensions:
 - a. Width: 27 inches.
 - b. Depth: 27 inches.
 - c. Height: 44 inches.
 4. Drum: Perforated stainless steel.
 - a. Capacity: 4.6cu. ft.
 5. Controls: Rotary-dial.
 - a. Wash Cycles: 13 wash cycles, including regular, delicate, and permanent press.
 - b. Wash Temperatures: 6 settings.
 - c. Speed Combinations: Variable.
 6. Electrical Power: 120 V, 60 Hz, 1 phase, 10 A.
 7. Motor: Manufacturer's standard with built-in overload protector.
 8. Features:
 - a. Agitator: Impeller (without spindle).
 - b. Self-cleaning lint filter.
 - c. Unbalanced-load compensator.
 - d. Inlet Hoses: Minimum length 60 inches.
 - e. Drain Hoses: Minimum length 48 inches.
 - f. Self-leveling legs.
 - g. Automatic dispenser for bleach.
 - h. Spin-cycle safety switch.
 - i. End-of-cycle signal.
 - j. Extra-rinse option.
 - k. Delay-wash option.
 - l. Electronic temperature control.
 - m. Water levels automatically set.
 9. ENERGY STAR: Provide appliances that qualify for the EPA/DOE ENERGY STAR product-labeling program.
 10. Appliance Finish: Enamel.
 - a. Color: White.
 11. Front-Panel Finish: Porcelain enamel.
 - a. Panel Color: White.
- B. Clothes Washer, ADA: Complying with AHAM HLW-1.
1. Basis-of-Design Product: Subject to compliance with requirements, provide the following:
 - a. GE Appliances; a Haier Company: Model #GFW650SSNWW.
 - b. Approved substitution:

**NISQUALLY STATE PARK
NEW FULL SERVICE PARK – PHASE 2**

2. Type: Freestanding, top-loading unit.
 3. Dimensions:
 - a. Width: 28 inches.
 - b. Depth: 32 inches.
 - c. Height: 39 inches.
 - d. 75 inches.
 4. Drum: Perforated stainless steel.
 - a. Capacity: 4.8cu. ft.
 5. Controls: Rotary-dial.
 - a. Wash Cycles: Manufacturer's standard.
 - b. Wash/Rinse Temperatures: 5 settings.
 - c. Speed Combinations: 5.
 6. Electrical Power: 120 V, 60 Hz, 1 phase, 15 A.
 7. Motor: Manufacturer's standard with built-in overload protector.
 8. Features:
 - a. Agitator: Impeller (without spindle).
 - b. Self-cleaning lint filter.
 - c. Unbalanced-load compensator.
 - d. Inlet Hoses: Minimum length 60 inches.
 - e. Drain Hoses: Minimum length 48 inches.
 - f. Self-leveling legs.
 - g. Automatic dispenser for bleach.
 - h. Spin-cycle safety switch.
 - i. End-of-cycle signal.
 - j. Extra-rinse option.
 - k. Delay-wash option.
 - l. Electronic temperature control.
 - m. Water levels automatically set.
 9. ENERGY STAR: Provide appliances that qualify for the EPA/DOE ENERGY STAR product-labeling program.
 10. Appliance Finish: Stainless steel.
 11. Front-Panel Finish: Stainless steel.
- C. Clothes Dryer, Standard: Complying with AHAM HLD-1.
1. Basis-of-Design Product: Subject to compliance with requirements, provide the following:
 - a. GE Appliances; a Haier Company: Model #GTX33EASKWW.
 - b. Approved substitution:
 2. Type: Freestanding, frontloading, electric unit.

**NISQUALLY STATE PARK
NEW FULL SERVICE PARK – PHASE 2**

3. Dimensions:
 - a. Width: 27 inches.
 - b. Depth: 26.75 inches.
 - c. Height: 44 inches.
 4. Drum: Perforated stainless steel.
 - a. Capacity: 6.2cu. ft.
 5. Controls: Rotary-dial.
 6. Electric-Dryer Power: 208 V, 60 Hz, 4,400 W, 22 A.
 7. Features:
 - a. Removable lint filter.
 - b. Electronic temperature and moisture-level-sensor controls.
 - c. End-of-cycle signal.
 - d. Interior drum light.
 - e. Self-leveling legs.
 - f. Antibacterial cycle.
 - g. Auxiliary drying rack.
 - h. Built-in electrical power fuse.
 8. Appliance Finish: Enamel.
 - a. Color: White.
 9. Front-Panel Finish: Porcelain enamel.
 - a. Panel Color: White.
- D. Clothes Dryer, ADA: Complying with AHAM HLD-1.
1. Basis-of-Design Product: Subject to compliance with requirements, provide the following:
 - a. GE Appliances; a Haier Company: Model #GFD55ESSNWW.
 - b. Approved substitution:
 2. Type: Freestanding, top-loading unit.
 3. Dimensions:
 - a. Width: 28 inches.
 - b. Depth: 32 inches.
 - c. Height: 39-3/4 inches.
 - d. 75 inches.
 4. Drum: Perforated stainless steel.
 - a. Capacity: 7.8cu. ft.
 5. Controls: Rotary-dial.

**NISQUALLY STATE PARK
NEW FULL SERVICE PARK – PHASE 2**

6. Electrical Power: 120 V/208 V, 60 Hz, 4,400 W, 22 A.
7. Motor: Manufacturer's standard with built-in overload protector.
8. Features:
 - a. Removable lint filter.
 - b. Electronic temperature and moisture-level-sensor controls.
 - c. End-of-cycle signal.
 - d. Interior drum light.
 - e. Self-leveling legs.
 - f. Auxiliary drying rack.
 - g. Built-in electrical power fuse.
9. ENERGY STAR: Provide appliances that qualify for the EPA/DOE ENERGY STAR product-labeling program.
10. Appliance Finish: Stainless steel.
11. Front-Panel Finish: Stainless steel.

2.7 GENERAL FINISH REQUIREMENTS

- A. Protect mechanical finishes on exposed surfaces from damage by applying a strippable, temporary protective covering before shipping.
- B. Appearance of Finished Work: Noticeable variations in same piece are not acceptable. Variations in appearance of adjoining components are acceptable if they are within range of approved Samples and are assembled or installed to minimize contrast.

PART 3 - EXECUTION

3.1 EXAMINATION

- A. Examine substrates, areas, and conditions, with Installer present, for compliance with requirements for installation tolerances, power connections, and other conditions affecting installation and performance of residential appliances.
- B. Examine roughing-in for piping systems to verify actual locations of piping connections before appliance installation.
- C. Examine walls, ceilings, and roofs for suitable conditions where microwave ovens with vented exhaust fans will be installed.
- D. Prepare written report, endorsed by Installer, listing conditions detrimental to performance of Work.
- E. Proceed with installation only after unsatisfactory conditions have been corrected.

**NISQUALLY STATE PARK
NEW FULL SERVICE PARK – PHASE 2**

3.2 INSTALLATION

- A. Install appliances according to manufacturer's written instructions.
- B. Built-in Equipment: Securely anchor units to supporting cabinets or countertops with concealed fasteners. Verify that clearances are adequate for proper functioning and that rough openings are completely concealed.
- C. Freestanding Equipment: Place units in final locations after finishes have been completed in each area. Verify that clearances are adequate to properly operate equipment.
- D. Range Anti-Tip Device: Install at each range according to manufacturer's written instructions.

3.3 FIELD QUALITY CONTROL

- A. Perform the following tests and inspections with assistance of a factory-authorized service representative:
 - 1. Perform visual, mechanical, and electrical inspection and testing for each appliance according to manufacturers' written recommendations. Certify compliance with each manufacturer's appliance-performance parameters.
 - 2. Leak Test: After installation, test for leaks. Repair leaks and retest until no leaks exist.
 - 3. Operational Test: After installation, start units to confirm proper operation.
 - 4. Test and adjust controls and safeties. Replace damaged and malfunctioning controls and components.
- B. An appliance will be considered defective if it does not pass tests and inspections.
- C. Prepare test and inspection reports.

3.4 DEMONSTRATION

- A. Engage a factory-authorized service representative to train Owner's maintenance personnel to adjust, operate, and maintain residential appliances.

END OF SECTION

**NISQUALLY STATE PARK
NEW FULL SERVICE PARK – PHASE 2**

SECTION 115233 – DISPLAY MONITOR MOUNTS

PART 1 - GENERAL

1.1 SUMMARY

A. Section Includes:

1. Interior, full motion, display monitor mounting brackets.

1.2 ADMINISTRATIVE REQUIREMENTS

A. Coordination:

1. Coordinate layout and installation of display mount equipment with adjacent construction, including light fixtures, HVAC equipment, fire-suppression system, and partitions.

1.3 ACTION SUBMITTALS

- A. Product Data: For each type of product.

1.4 INFORMATIONAL SUBMITTALS

- A. Manufacturer's installation instructions.

PART 2 - PRODUCTS

2.1 WALL MOUNTING BRACKETS

- A. Flat Panel Full Motion TV Bracket (TV BRKT-1): Universal, low-profile, wall-mount type, heavy gage cold rolled steel monitor bracket.

1. Products: Subject to compliance with requirements, provide one of the following:

- a. Ergotron, Inc.: Neo-Flex Cantilever, UHD Model No. 61-132-223.
- b. Gabor: Model No. FSM-L.
- c. OmniMount: UCL-L.
- d. Peerless Industries, Inc.: Model No. SP850-UNL SmartMount Pull-Out Pivot Mount.
- e. Premier Mounts: Item No. AM175 Swingout Mount for Flat-Panel Displays.
- f. Sanus Systems: Model Code VLF613 Slim Full Motion TV Wall Mount.
- g. Video Mount Products: Model No. FP-LWAB.

2. Monitor Size Range: Minimum 32 inch to 80 inch diagonal.

**NISQUALLY STATE PARK
NEW FULL SERVICE PARK – PHASE 2**

3. Monitor Project from Wall: 1.9 inches minimum to 25 inches maximum.
 4. Weight Capacity: Maximum of 125 to 175 lbs., depending on model selected.
 5. Finish: Manufacturer's standard powder coating.
 6. Color: Black.
- B. Source Limitations for Display Monitor Mounts: Obtain mounting brackets and accessories, including necessary mounting hardware, from single manufacturer.

2.2 MISCELLANEOUS MATERIALS

- A. Anchors: Anchoring devices of type, size, material, and finish required for application indicated to provide secure attachment.

PART 3 - EXECUTION

3.1 PREPARATION

- A. Prior to installing display monitor mount equipment, verify blocking is in place and ready to receive equipment.
- B. Verify power outlets and other connections associated with display monitors are installed and working properly.

3.2 INSTALLATION

- A. Install display monitor mount equipment level, plumb, true, and aligned with adjacent materials. Use concealed metal shims where necessary for alignment.

3.3 ADJUSTING

- A. Adjust angle of monitor and display brackets.

3.4 CLEANING AND PROTECTION

- A. Clean, repair, or replace interior finishes adjacent to display equipment that is soiled or damaged during installation of display equipment.
- B. Touch up factory-applied finishes to restore damaged or soiled areas.
- C. Protect installed products from damage by construction activities during remainder of construction period.

END OF SECTION

**NISQUALLY STATE PARK
NEW FULL SERVICE PARK – PHASE 2**

SECTION 118129 – FACILITY FALL PROTECTION

PART 1 - GENERAL

1.1 SUMMARY

A. Section Includes:

1. Fall protection tie-back anchors.

1.2 ADMINISTRATIVE REQUIREMENTS

A. Preinstallation Meeting: Conduct meeting at Project site.

1. Attendees: Contractor, Installer, manufacturer's representative, and representatives of other affected trades
2. Agenda: Review safety restraint system procedure, acceptance of substrate surfaces, and coordination with other entities affecting this Work.
3. Tour Project Site Areas. Inspect and discuss conditions of substrate, structural supports, access and proposed use of system, penetrations required at anchor locations, and preparatory Work performed by others.
4. Schedule meeting a minimum of 1 week prior to start of installation.

1.3 ACTION SUBMITTALS

A. Product Data: Include the following:

1. Manufacturer's product data highlighting pertinent information. Include performance data, physical characteristics, and limitations of fall protection tie-back anchors.
2. Construction and fabrication of fall protection tie-back anchors.

B. Shop Drawings: Provide Shop Drawings indicating the following:

1. Complete layout and configuration of fall protection tie-back, including components and accessories.
2. Design and fabrication details, hardware, and installation details.
3. Locations of anchors, dimensions, description of materials and finishes, general construction, specific modifications, component connections, anchorage methods, hardware, and installation procedures, for complete system.
4. Interface with adjacent construction.
5. Submit Shop Drawings that have been engineered and certified by professional engineer licensed in the State of in which Project is located.
 - a. Include seal and signature of professional engineer on Shop Drawings.

**NISQUALLY STATE PARK
NEW FULL SERVICE PARK – PHASE 2**

C. Delegated-Design Submittal: For fall protection tie-back anchors indicating compliance with performance and design criteria.

1. Include analysis data signed and sealed by qualified professional engineer responsible for their preparation.

1.4 INFORMATIONAL SUBMITTALS

A. Qualification Data: For professional engineer indicating experience providing delegated-design engineering services of the kind indicated.

1. Include documentation that engineer is licensed in state in which Project is located

B. Test Reports: Certified test reports showing compliance with specified performance characteristics and physical properties.

C. Certification: Written statement signed by fall protection tie-back anchor manufacturer certifying the following:

1. Fall protection tie-back anchors comply with requirements of this Section and is suitable for type of roof system, roof deck, and location on roof.
2. Fall protection tie-back anchors will maintain watertight continuity of roofing system.
3. Installers are trained and certified by fall protection tie-back anchor manufacturer.

D. Certificates: Product certificates signed by fall protection tie-back anchor manufacturer certifying the following:

1. Materials comply with specified performance characteristics and criteria and physical requirements.
2. Mill Certificates: Signed by manufacturers of stainless-steel certifying that products furnished comply with requirements.

E. Welding certificates.

F. Manufacturer's installation instructions.

G. Manufacturer's field test reports.

1.5 CLOSEOUT SUBMITTALS

A. Operations and Maintenance Data: For installed products. Include the following:

1. Manufacturer's instructions for safe use of specified systems and equipment.
2. Maintenance requirements and parts catalog giving complete list of repair and replacement parts with cuts and identifying numbers.
3. Methods used to control employee exposure to falls while working in Danger Zone.

**NISQUALLY STATE PARK
NEW FULL SERVICE PARK – PHASE 2**

4. Identification of the following:
 - a. Drop zones and recommended drop sequences, including equipment to be used.
 - b. Personal fall protection requirements and applicable procedures for securing equipment.
 - c. Dangerous areas on roof by highlighting Danger Zones on Drawings.
 - d. Equipment limitations, load ratings, and special use conditions.
 - e. Access and egress to Work locations and storage areas for permanent or transportable building maintenance equipment.
 5. Emergency and rescue procedures, and means of communications used during such procedures.
 6. Description of means and methods used to transfer equipment from drop location or between building levels.
 7. Provisions for pre-operational, operational, and maintenance inspections.
 8. Record Drawings indicating equipment locations and details. Ensure drawings are posted adjacent to exits from roof.
- B. System Equipment Manual and Inspection Log Book, with completed "Initial Inspection - Certification for Use" and "Inspection Sign-Off" forms completed.

1.6 QUALITY ASSURANCE

- A. Manufacturer Qualifications: A company with a minimum of 5 years documented experience specializing in design, fabrication, and installation of fall protection tie-back anchors, and capable of providing field service representation during construction and approving application method.
- B. Installer's Qualifications: Firm with not less than 5 years of experience in installation of fall protection tie-back anchors similar in complexity to that required for this Project, including specific requirements indicated.
 1. Employees of or trained and certified by fall protection tie-back anchor manufacturer.
 2. Able to document not less than 5 successfully completed comparable scale projects using this equipment.
- C. Delegated-Design Engineer Qualifications: Professional engineer experienced in providing delegated-design engineering services of the kind indicated and is legally qualified to practice in state where Project is located.
- D. Welding Qualifications: Qualify procedures and personnel according to the following:
 1. AWS D1.1.
 2. AWS D1.3.
 3. AWS D1.6.
 4. Use welders certified by AWS and State project is located for structural welding, and who have undergone recertification in the last 12 months.

**NISQUALLY STATE PARK
NEW FULL SERVICE PARK – PHASE 2**

1.7 DELIVERY, STORAGE, AND HANDLING

- A. Packing and Shipping: Deliver products in original unopened packaging with legible manufacturer's identification.
- B. Storage and Protection:
 - 1. Store materials protected from exposure to harmful weather conditions and at temperature conditions recommended by manufacturer.

1.8 WARRANTY

- A. Special Warranty: Manufacturer's standard form in which manufacturer agrees to repair or replace components of fall protection tie-back anchors that do not comply with requirements or that fail in materials or workmanship within specified warranty period.
 - 1. Failures include the following:
 - a. Structural failures including excessive deflection.
 - b. Deterioration of metals and other materials beyond normal weathering.
 - c. Failure of operating components.
 - 2. Warranty Period: 1 year from date of Substantial Completion.

PART 2 - PRODUCTS

2.1 DESCRIPTION

- A. Regulatory Requirements: Comply with the following regulations:
 - 1. AISC – American Institute of Steel Construction.
 - 2. OSHA - Occupational Safety and Health Administration, Part 1910 - Occupational Safety and Health Standards, for the following:
 - a. Fall Protection Standards: § 1910.29, Subpart D. (29 CFR part 1926, Subpart M).
 - 3. Washington State Department of Labor and Industries (L&I).
 - 4. DOSH – Washington State Division of Occupational Safety and Health.
 - 5. WAC – Washington Administrative Code: Chapter 296-155 WAC, Part C-1, Fall Protection requirements for Construction.

2.2 PERFORMANCE CRITERIA

- A. Anchor Components: Comply with ASME A120.1. Ensure compatibility with industry standard equipment. Locate anchorages to suit specified suspension equipment.

**NISQUALLY STATE PARK
NEW FULL SERVICE PARK – PHASE 2**

B. Fall Protection Safety Anchors and Supports:

1. General Safety Factor: Design primary support equipment to sustain, without failure, a minimum of 4 times maximum static working load applied or transmitted to components.
2. Fall Arrest Safety Anchors:
 - a. Fall arresting force safety factor of 2 to 1 without permanent deformation: 1,800 lbs. minimum.
 - b. Fall arresting force against fracture or detachment: 5,000 lbs. minimum.
 - c. Static working load of 1,000 lbs. in any direction.
 - d. Provide 2 independent anchors designated for suspension and fall protection in each area of suspension.
 - e. Design anchor components to provide adequate attachment to building and suited to current fall protection practices. Ensure compatibility with industry standard equipment.
 - f. Ensure anchor components conform to proper engineering principles and have been designed by a professional engineer qualified in design of fall protection equipment, its applications, and safety requirements.

2.3 COMPONENTS APPLICABLE TO EACH SYSTEM

- A. Safety Anchor U-Bars: Stainless steel, Type 304, according to ASTM A276 with 35 Ksi minimum yield strength High-strength, low-alloy structural steel, ASTM A572, with 44 Ksi minimum yield strength, hot-dip galvanized according to ASTM A123.
 1. U-Bar Size: Minimum 0.75 inch dia. bar, with 1.5 to 2 inch eye opening as determined by fall protection equipment manufacturer.
- B. Securement Bolts, Nuts, and Washers: Stainless steel, Type 304, according to ASTM A276 with 35 Ksi minimum yield strength High-strength, low-alloy structural steel, ASTM A572, with 42 Ksi minimum yield strength, hot-dip galvanized according to ASTM A123.
 1. Exposed Fasteners: Provide with non-corrosive coating and EPDM washers, specified for type and quality, and as designated by manufacturer for design loads.
- C. Miscellaneous Bolts, Nuts, and Washers: High-strength, low-alloy structural steel, ASTM A572, with 44 Ksi minimum yield strength, hot-dip galvanized according to ASTM A123.

2.4 FALL PROTECTION TIE-BACK ANCHORS

- A. Closed Loop Top Commercial Roof Anchors: Bolt-through type, OSHA-compliant fall protection, closed, stainless steel loop top, welded to pipe riser, welded to square baseplate as indicated on Drawings.
 1. Products: Subject to compliance with requirements, provide the following:
 - a. American Anchor: Bolt Through Roof Anchor.
 - b. Atlas Anchor Systems USA, Co.: CS Series.
 - c. Diversified Fall Protection: Rigid Post Single Point Anchors.

**NISQUALLY STATE PARK
NEW FULL SERVICE PARK – PHASE 2**

- d. Guardian Fall Protection Inc.: CB Series Anchorage Connector.
 - e. Pro-Bel Group of Companies: PBE7 Series Roof Anchors.
 - f. Rooftop Anchors, Inc.: Axis Single Point Anchorage.
 - g. Safeguard Industries: SRA Series.
 - h. Super Anchor Safety: CRA Series Loop Top Roof Anchors.
- 2. Steel Type: ASTM A123 hot-dip galvanized and Type 304 stainless.
 - 3. Tensile Strength: Minimum 5,000 lbf.
 - 4. Riser Height: As indicated on Drawings.
 - 5. Closed Loop Top/ U-Bar Opening: 1.375 to 2 inch.
 - a. U-Bar and D-Ring Size: Minimum 0.75 inch dia. bar, with as determined by fall protection equipment manufacturer:
 - 6. Pipe Riser: Schedule 40 with minimum 4 inch OD.
 - 7. Baseplate Size and Thickness: As required to meet design requirements.
- B. Upright Roof Anchors: Provide one of the following types of upright roof anchors as determined by fall protection equipment manufacturer:
- 1. Hollow Steel Section (HSS) Piers: High-strength, low-alloy structural steel, ASTM A572, with 50 Ksi minimum yield strength, hot dipped galvanized according to ASTM A123.
 - 2. Anchor Pipe: ASTM A53, 2-2/1 inch dia. Extra-Heavy Schedule 80, Type F, Grade A steel, or as required by design loads; hot-dip galvanized according to ASTM A123.
 - a. Wall Thickness: Design to meet Project design requirements indicated.
 - b. Height: As necessary to extend through roofing system and provide required performance.
- C. Base Plate and Other Sections: High-strength, low-alloy structural steel, ASTM A572, with 44 Ksi minimum yield strength, hot-dip galvanized according to ASTM A123.
- 1. Wall Thickness: Design to meet Project design requirements indicated.
- D. Roof Anchor Flashing:
- 1. Deck Flange Flashing: Heat-shrink rubber collar flashing as recommended by manufacturer of roofing membrane. Comply with requirements of roofing membrane manufacture and Section 076200 – Sheet Metal Flashing and Trim. Seal top of flashing with conformable mastic tape and torch applied heat-shrink rubber collar flashing.
 - a. Location: Single ply membrane roofing.
- 2.5 STAINLESS-STEEL FINISHES
- A. Surface Preparation: Remove tool and die marks and stretch lines, or blend into finish.
 - B. Finish: Manufacturer's standard for specific stainless steel components.

**NISQUALLY STATE PARK
NEW FULL SERVICE PARK – PHASE 2**

2.6 STEEL AND IRON FINISHES

A. Galvanizing:

1. Hot-dip galvanize steel components, including hardware, after fabrication.
2. Comply with ASTM A123 for hot-dip galvanized pipes, plates and other steel and iron products not considered hardware.
3. Comply with ASTM A153 for hot-dip galvanized steel and iron hardware.
4. Do not quench or apply post galvanizing treatments that might interfere with paint adhesion.
5. Vent Holes: Do not locate galvanizing vent holes on horizontal surface. Fill vent and drain holes that are exposed in finished Work after galvanizing, unless indicated to remain as weep holes, by plugging with zinc solder and filing off smooth to match adjacent finish.

2.7 FABRICATION

- A. Coordinate fall protection tie-back anchors with supporting building structure. Locate and fabricate anchoring devices as determined by manufacturer's engineer to provide adequate support for system's intended use.
- B. Fabricate Work true to dimension, square, plumb, level, and free from distortion or defects detrimental to appearance and performance. Grind off surplus welding material and ensure exposed internal corners have smooth lines.
- C. Fabricate joints to prevent ponded or trapped water. Provide weep holes to drain water where determined by fabricator.
- D. Fabricate base plates as appropriate for various substructure connections. Predrill holes in base plates designed to be anchored with fasteners.

PART 3 - EXECUTION

3.1 EXAMINATION

- A. Examine areas and conditions under which Work is to be performed and identify conditions detrimental to proper or timely completion.
 1. Promptly report to Architect conditions that deviate from approved Shop Drawings or defects in workmanship that would cause an unsafe installation.
 2. Correct conditions detrimental to timely and proper execution of Work.
 3. Do not proceed until unsatisfactory conditions have been corrected.
 4. Commencement of installation constitutes acceptance of conditions and responsibility for satisfactory performance by Installer.
 5. Correct faults occurring in Work of this Section due to acceptance of unsatisfactory conditions at no additional cost to Owner.
- B. Verify structural steel designed to receive fall protection tie-back anchors has adequate bearing surface as indicated on approved Shop Drawings to ensure 100 percent weld.

**NISQUALLY STATE PARK
NEW FULL SERVICE PARK – PHASE 2**

3.2 INSTALLATION

- A. Install fall protection equipment according to manufacturer’s instructions and approved Shop Drawings. Install fall protection equipment level, tightly fitted, and flush to adjacent surfaces as needed for proper installation.
- B. Coordinate installation of fall protection tie-back anchors with roofing installation to ensure a watertight and warrantable condition of roofing system. Directly flash fall protection tie-back anchors into roofing in manner compatible with roofing system and fall protection tie-back anchors.
- C. When components come into contact with dissimilar metals, keep surfaces from direct contact to prevent corrosion.
- D. Deform threads of tail end of fall protection tie-back anchor studs after nuts have been tightened to prevent accidental removal and vandalism.

3.3 FIELD QUALITY CONTROL

- A. Testing Agency: Owner will engage qualified independent testing and inspecting agency to inspect installation of fall protection tie-back anchors in progress.
- B. Onsite inspection of fall protection tie-back anchors welded to structure shall be performed by an AWS Certified Welding Inspector verifying, in writing, size and quality of welds. Inspection shall be performed on each piece of fall protection equipment before roofing material is installed.
- C. Test fall protection equipment under supervision of professional engineer with experience with suspended maintenance equipment and manufacturers guidelines.
- D. Manufacturer’s Field Services: Schedule manufacturer’s technical representative for site visits to review Work as follows:
 - 1. After delivery and storage of products.
 - 2. When preparatory Work is complete, but before installation begins.
 - 3. Regular intervals during progress of Work and at 25 percent and 60 percent of completion.
 - 4. Upon completion of Work, after cleaning is carried out.
- E. Testing: Test on site 100 percent of fall protection tie-back anchors relying upon chemical adhesive fasteners using load cell test apparatus per manufacturer's written recommendations.

3.4 ADJUSTING

- A. Verify that completed Work has been installed correctly and products function properly. Make adjustments where needed to ensure satisfactory operation.
- B. Complete inspection logbook to certify system for use noting deviations, changes, or corrections from approved Shop Drawings. Provide Record Drawings of anchor layout plan on 11 inch by 17 inch paper or larger together with annual inspection with log book.

**NISQUALLY STATE PARK
NEW FULL SERVICE PARK – PHASE 2**

3.5 CLEANING

- A. After roofing operations are completed, clear fall protection tie-back anchor areas of aggregate or other debris which may interfere with fall protection equipment operation.

3.6 CLOSEOUT ACTIVITIES

- A. Demonstrate operation and maintenance procedures to Owner.

END OF SECTION

**NISQUALLY STATE PARK
NEW FULL SERVICE PARK – PHASE 2**

SECTION 121200 – WALL DECORATIONS

PART 1 - GENERAL

1.1 SUMMARY

A. Section Includes:

1. Digitally printed wall art.
2. Wall track and accessories for hanging wall art.

B. Related Requirements:

1. Section 102600 – Wall and Door Protection, for standard wall and door protection products.

1.2 ADMINISTRATIVE REQUIREMENTS

A. Coordination:

1. Furnish templates for placement of -anchorage devices embedded in permanent construction by other installers.

1.3 ACTION SUBMITTALS

A. Product Data: For each type of product.

B. Shop Drawings: For printed wall art.

1. Include fabrication and installation details and attachments to other Work.
2. Show wall art mounting heights and accessories.
3. Show graphic elements and layout for each art piece at least 1/2 size.

C. Samples for Verification: For each type of wall decoration showing components and required finishes, in manufacturer's standard size unless otherwise indicated and as follows:

1. Wall Art: Not less than 12 inches square, including corner.
2. Exposed Accessories: Full-size Sample of each accessory type.
3. Wall Hanging System: For the following to verify design, operation, and finish requirements.
 - a. Wall Track: 6 inches long.
 - b. End Cable and Gripper Hook: Full-size Samples.
4. Approved full-size Samples will be returned to Contractor for use in Project.

D. Product Schedule: Use same designations indicated on Material and Finish Legend.

**NISQUALLY STATE PARK
NEW FULL SERVICE PARK – PHASE 2**

1.4 INFORMATIONAL SUBMITTALS

- A. Qualification Data: For Installer and fabricator.
- B. Sample Warranty: For special warranty.

1.5 CLOSEOUT SUBMITTALS

- A. Maintenance Data: For wall decorations to include in maintenance manuals.

1.6 QUALITY ASSURANCE

- A. Fabricator Qualifications: Company specializing in fabricating specified types of wall art with a minimum 3 years of experience of comparable scale and scope as this Project.
- B. Manufacturer's Qualifications: Firm with not less than 5 years of experience in manufacturing hanging display systems similar to those required for this Project.

1.7 DELIVERY, STORAGE, AND HANDLING

- A. Deliver and store products in manufacturer's unopened packaging bearing brand name and manufacturer's identification until ready for installation.
- B. Handling: Handle materials to avoid damage.

1.8 FIELD CONDITIONS

- A. Ambient Conditions: Do not deliver or install room identification signage until spaces are enclosed and weathertight, wet Work in spaces is complete and dry, and temporary HVAC system is operating and maintaining ambient temperature and humidity conditions at occupancy levels during remainder of construction period.

1.9 WARRANTY

- A. Special Warranty: Manufacturer agrees to repair or replace components of wall art that fail in materials or workmanship within specified warranty period.
 - 1. Failures include the following:
 - a. Deterioration of finishes beyond normal weathering.
 - b. Separation or delamination of sheet materials and components.
 - 2. Warranty Period: 2 years from date of Substantial Completion.

**NISQUALLY STATE PARK
NEW FULL SERVICE PARK – PHASE 2**

PART 2 - PRODUCTS

2.1 MANUFACTURERS

- A. Source Limitations: Obtain wall decorations and art hanging display systems from single source from single manufacturer.

2.2 DIGITALLY PRINTED WALL ART

- A. Printed Wall Protection (WP-X): Custom wall art fabricated from digital prints sealed between clear plastic sheet, vinyl film, and styrene backer.
 - 1. Products: Subject to compliance with requirements, provide the following:
 - a. InPro SignScape; InPro Corporation: Signscape Digitally Printed Wall Art.
 - b. Approved substitution.
 - 2. Sizes: As indicated on Drawings.
 - 3. Mounting: Surface mounted to wall with 2-face tape and sealant.
- B. Artwork: Architect will furnish artwork to Contractor for use in production of digitally printed wall art.

2.3 HANGING AND DISPLAY SYSTEM

- A. Hanging Display Systems. Provide materials and components required to provide a complete system for hanging art.
 - 1. Basis-of-Design Product: Subject to compliance with requirements, provide the following:
 - a. AS Hanging Display Systems: Classic Gallery System.
 - b. Approved substitution.
 - 2. Aesthetic: Commercial grade track for art display.
 - 3. Wall Track: Open-face.
 - 4. Track Weight Capacity: Minimum 300 lbs. per 6 foot track section.
- B. Wall Track: Extruded C-shaped aluminum with predrilled anchor holes at 8 inches on center and 4 inches from each end.
 - 1. Track Size:
 - a. Height: 1.17 inches.
 - b. Depth: 0.39 inch.
 - c. Face Opening: 0.54 inch.
 - d. Length: 72 inches.

**NISQUALLY STATE PARK
NEW FULL SERVICE PARK – PHASE 2**

2. Finish: Manufacturer's standard powder coating
 - a. Color: Warm White, semi-gloss.
 3. Provide manufacturer's track ends matching material and finish as track.
- C. Vertical Component: Cable mounted to molded polymer C-hook that connects to wall track.
1. Basis-of-Design Product: C-End Cable, Model C2010.
 2. Cable Material: Stainless steel made of 7x7 strands.
 3. Cable Length: 48 to 72 inches.
 4. Cable Weight Capacity: Minimum 45 lbs. per cable.
- D. Art Hanging Gripper: Engineered polymer unit designed to provide hook for art hanging that grips cable in adjustable positions.
1. Basis-of-Design Product: Secure Gripper Hook, Model H3002.
 2. Gripper Weight Capacity: Minimum 40 lbs. per gripper.

2.4 PICTURE HANGING RAIL SYSTEM

- A. Picture Hanging Rail System:
1. Basis-of-Design Product: Subject to compliance with requirements, provide the following:
 - a. Arakawa Hanging Systems, Inc.: MR-3 Picture Rail System.
 - b. Approved substitution.
 2. Rails: Provide aluminum hanging rails, complete with installation hardware.
 3. Length: 6 feet.
 4. Finish: Clear anodized.
- B. Stainless Steel Rail Clips With Hanging Cables and Midway Grippers: Furnish MRD-32 stainless steel Rail Clips complete with 3/32 inch cable with self-gripping, spring release action picture hooks.
1. Basis-of-Design Product: Subject to compliance with requirements, provide the following:
 - a. Arakawa Hanging Systems, Inc.: MR-3 Picture Rail System.
 - b. Approved substitution.
 2. Length: 6 feet.
 3. Load Capacity: 186 lbs. (based on 2 cables)

**NISQUALLY STATE PARK
NEW FULL SERVICE PARK – PHASE 2**

2.5 MATERIALS

- A. Modified Polyethelene Terephtalate Glycol (PETG): ASTM D5047, glycol-modified polyethylene terephtalate copolyester that is a clear amorphous thermoplastic.
 - 1. Thickness: Minimum 0.060 inch.
- B. Vinyl Film: UV-resistant, non-yellowing vinyl film with pressure-sensitive, permanent adhesive and release liner on back; suitable for applications where scheduled.
 - 1. Thickness: Manufacturer's standard.
- C. Backer Sheet: Minimum 0.020 inch thick high impact styrene.
- D. Inks: UV-curable and recommended by manufacturer for optimum adherence to surface and is UV and water resistant for colors and exposure indicated.

2.6 ACCESSORIES

- A. Fasteners and Anchors: Manufacturer's standard as required for secure anchorage of wall art and art hanging display system, noncorrosive and compatible with each material joined, and complying with the following:
 - 1. Provide concealed fasteners and anchors unless indicated to be exposed.
 - 2. Provide stainless-steel devices unless otherwise indicated.
 - 3. Exposed Metal-Fastener Components, General:
 - a. Fabricated from same basic metal and finish of fastened metal unless otherwise indicated.
 - b. Fastener Heads: For nonstructural connections, use countersunk screws and bolts with tamper-resistant slots unless otherwise indicated.
 - 4. Sign Mounting Fasteners: Tamper-proof type devices.
 - a. Concealed Studs: Concealed (blind), threaded studs screwed into back of sign assembly unless otherwise indicated.
 - b. Projecting Studs: Threaded studs with sleeve spacer, screwed into back of sign assembly, unless otherwise indicated.
 - c. Through Fasteners: Exposed metal fasteners matching sign finish, with type of head indicated, and installed in predrilled holes.
 - 5. Inserts: Furnish inserts to be set by other installers into concrete or masonry Work.
- B. 2-Face Tape: Manufacturer's standard high-bond, foam-core tape, 0.045 inch thick, with adhesive on both sides.
- C. Joint Sealant: SLNT-AL1 as specified in Section 079200 – Joint Sealants.
 - 1. Color: As selected by Architect to match wall art manufacturer's colors.

**NISQUALLY STATE PARK
NEW FULL SERVICE PARK – PHASE 2**

- D. Adhesive: As recommended by sign manufacturer.

2.7 FABRICATION

- A. Provide manufacturer's standard assemblies according to requirements indicated.
 - 1. Preassemble wall art in shop to greatest extent possible. Disassemble wall art and assemblies only as necessary for shipping and handling limitations. Clearly mark units for reassembly and installation.
 - a. Apply markings in locations concealed from view after final assembly.
 - 2. Mill joints to a tight, hairline fit. Form assemblies and joints exposed to weather to resist water penetration and retention.
 - 3. Conceal connections if possible; otherwise, locate connections where they are inconspicuous.
 - 4. Provide rabbets, lugs, and tabs necessary to assemble components and to attach to existing work.
 - a. Drill and tap for required fasteners.
 - b. Use concealed fasteners where possible; use exposed fasteners that match wall art finish.

PART 3 - EXECUTION

3.1 EXAMINATION

- A. Examine substrates, areas, and conditions, with Installer present, for compliance with requirements for installation tolerances and other conditions affecting performance of Work.
- B. Verify that substrates are within tolerances to accommodate wall art and art hanging display system without gaps or irregularities between backs of units and support surfaces unless otherwise indicated.
- C. Verify that anchorage devices embedded in permanent construction are correctly sized and located to accommodate signs.
- D. Proceed with installation only after unsatisfactory conditions have been corrected.

3.2 PREPARATION

- A. Thoroughly clean surfaces prior to installation to remove dust, debris, loose particles, and other substances that could be detrimental to proper wall art installation.
- B. Prepare surfaces using methods recommended by manufacturer for achieving best result for substrate under Project conditions.

**NISQUALLY STATE PARK
NEW FULL SERVICE PARK – PHASE 2**

3.3 INSTALLATION OF WALL ART

- A. Install wall art using mounting methods indicated and according to manufacturer's written instructions.
1. Install wall art level, plumb, true to line, and at locations and heights indicated, with wall art surfaces free of distortion and other defects in appearance.
 2. Install wall art so they do not protrude or obstruct according to accessibility standard.
 3. Before installation, verify that wall art surfaces are clean and free of materials or debris that would impair installation.
- B. Mounting Methods:
1. 2-Face Tape: Clean bond-breaking materials from substrate surface and remove loose debris.
 - a. Apply tape strips symmetrically to back of sign and of suitable quantity to support weight of wall art without slippage.
 - b. Place strips a minimum of 1/4 inch away from wall art edge to prevent visibility at wall art edges.
 - c. Place wall art in position, and push to engage tape adhesive.
 2. Adhesive: Clean bond-breaking materials from substrate surface and remove loose debris.
 - a. Apply linear beads or spots of adhesive symmetrically to back of wall art and of suitable quantity to support weight of wall art after cure without slippage.
 - b. Keep adhesive away from edges to prevent adhesive extrusion as wall art is applied and to prevent visibility of cured adhesive at wall art edges.
 - c. Place wall art in position, and push to engage adhesive.
 - d. Temporarily support wall art in position until adhesive fully sets.
 3. Through Fasteners: Drill holes in substrate using predrilled holes in wall art as template.
 - a. Countersink holes in wall art if required.
 - b. Place wall art in position and flush to surface.
 - c. Install through fasteners and tighten.

3.4 INSTALLATION OF ART HANGING DISPLAY SYSTEM

- A. Install art hanging display system in accordance with manufacturer's instructions, approved submittals, and in proper relationship with adjacent construction.

3.5 ADJUSTING

- A. Remove and replace damaged or deformed wall art and art hanging display system and wall art and art hanging display system that do not comply with specified requirements. Replace wall art and art hanging display system with damaged or deteriorated finishes or components that cannot be successfully repaired by finish touchup or similar minor repair procedures.

**NISQUALLY STATE PARK
NEW FULL SERVICE PARK – PHASE 2**

3.6 CLEANING

- A. Remove temporary protective coverings and strippable films as products are installed.
- B. On completion of installation, clean exposed surfaces according to manufacturer's written instructions, and touch up minor nicks and abrasions in finish.
 - 1. Maintain wall art in a clean condition during construction and protect from damage until acceptance by Owner.
- C. Clean installed wall art and remove excess materials.
- D. Deliver unused cable and fittings to Owner.

3.7 PROTECTION

- A. Protect installed products until completion of project.
- B. Touch-up, repair, or replace damaged products before Substantial Completion.

END OF SECTION

**NISQUALLY STATE PARK
NEW FULL SERVICE PARK – PHASE 2**

SECTION 122113 – HORIZONTAL LOUVER BLINDS

PART 1 - GENERAL

1.1 SUMMARY

- A. Section Includes:
1. Horizontal louver blinds with aluminum slats.

1.2 ACTION SUBMITTALS

- A. Product Data: For each type of product.
- B. Shop Drawings: For horizontal louver blinds, include fabrication and installation details.
- C. Samples for Verification: For each type and color of horizontal louver blind indicated.
1. Slat: Not less than 12 inches long.
 2. Tapes: Full width, not less than 6 inches long.
 3. Horizontal Louver Blind: Full-size unit, not less than 16 inches wide by 24 inches long.
 4. Valance: Full-size unit, not less than 12 inches wide.
- D. Product Schedule: For horizontal louver blinds. Use same designations indicated on Drawings.

1.3 CLOSEOUT SUBMITTALS

- A. Maintenance Data: For horizontal louver blinds to include in maintenance manuals.

1.4 MAINTENANCE MATERIAL SUBMITTALS

- A. Furnish extra materials, from the same product run, that match products installed and that are packaged with protective covering for storage and identified with labels describing contents.
1. Horizontal Louver Blinds: Full-size units equal to 5 percent of quantity installed for each size, color, texture, pattern, and gloss indicated, but no fewer than 2 units.

1.5 QUALITY ASSURANCE

- A. Mockups:
1. Approval of mockups does not constitute approval of deviations from Contract Documents contained in mockups unless Architect specifically approves such deviations in writing.
 2. Subject to compliance with requirements, approved mockups may become part of completed Work if undisturbed at time of Substantial Completion.

**NISQUALLY STATE PARK
NEW FULL SERVICE PARK – PHASE 2**

1.6 DELIVERY, STORAGE, AND HANDLING

- A. Deliver horizontal louver blinds in factory packages, marked with manufacturer, product name, and location of installation using same designations indicated on Drawings.

1.7 FIELD CONDITIONS

- A. Environmental Limitations: Do not install horizontal louver blinds until construction and wet and finish Work in spaces, including painting, is complete and dry and ambient temperature and humidity conditions are maintained at the levels indicated for Project when occupied for its intended use.
- B. Field Measurements:
 - 1. Where horizontal louver blinds are indicated to fit to other construction, verify dimensions of other construction by field measurements before fabrication and indicate measurements on Shop Drawings.
 - 2. Allow clearances for operating hardware of operable glazed units through entire operating range. Notify Architect of installation conditions that vary from Drawings.
 - 3. Coordinate fabrication schedule with construction progress to avoid delaying the Work.

PART 2 - PRODUCTS

2.1 MANUFACTURERS

- A. Source Limitations: Obtain horizontal louver blinds from single source from single manufacturer.

2.2 HORIZONTAL LOUVER BLINDS, ALUMINUM SLATS

- A. Products: Subject to compliance with requirements, provide one of the following:
 - 1. CACO Inc. Window Fashions: Signature Series Malibu 6 and 8.
 - 2. Hunter Douglas Contract: Model CE61 1” Mini Aluminum Blind.
 - 3. Levolor; a Newell Rubbermaid company: Riviera Contract 1” Blind.
 - 4. Springs Window Fashions, LLC: Bali Horizontal Blinds.
 - 5. Approved substitution
- B. Slats: Aluminum; alloy and temper recommended by producer for type of use and finish indicated; with crowned profile and radiused corners.
 - 1. Width: 1 inch.
 - 2. Thickness: Manufacturer's standard but not less than 0.006 inch.
 - 3. Spacing: Manufacturer's standard.
 - 4. Finish: Ionized antistatic, dust-repellent, baked polyester finish.
 - 5. Features:
 - a. Lift-Cord Rout Holes: Minimum size required for lift cord and located near back (outside) edge of slat to maximize slat overlap and minimize light gaps between slats.
- C. Headrail: U-shaped, 0.025 inch thick formed steel; long edges returned or rolled, with manufacturer's baked enamel finish. Headrails fully enclose operating mechanisms.

**NISQUALLY STATE PARK
NEW FULL SERVICE PARK – PHASE 2**

1. Size: Nominal 1 inch high by 1-1/2 inch wide.
 2. Capacity: 1 blind per headrail unless otherwise indicated.
 3. Ends: Capped or plugged.
 4. Manual Lift Mechanism:
 - a. Lift-Cord Lock: Variable; stops lift cord at user-selected position within blind full operating range.
 - b. Operator: Extension of lift cord(s) through lift-cord lock mechanism to form cord pull.
 5. Manual Tilt Mechanism: Enclosed worm-gear mechanism and linkage rod that adjusts ladders.
 - a. Tilt: Full.
 - b. Operator: Clear-plastic wand, hexagonal shaped.
 - c. Over-Rotation Protection: Manufacturer's detachable operator or slip clutch to prevent over rotation of gear.
 6. Manual Lift-Operator and Tilt-Operator Lengths: Length required to extend to 48 inches above floor level when blind is fully closed.
 7. Manual Lift-Operator and Tilt-Operator Locations: Manufacturer's standard unless otherwise indicated.
- D. Bottom Rail: Formed-steel or extruded-aluminum tube that secures and protects ends of ladders and lift cords and has plastic- or metal-capped ends.
1. Type: Manufacturer's standard.
 2. Color: Match headrail.
- E. Lift Cords: Manufacturer's standard braided cord.
- F. Ladders: Evenly spaced across headrail at spacing that prevents long-term slat sag.
1. Type: Braided cord.
- G. Valance: Manufacturer's standard.
- H. Mounting Brackets: With spacers and shims required for blind placement and alignment indicated.
1. Type: As indicated.
 2. Intermediate Support: Provide intermediate support brackets to produce support spacing recommended by blind manufacturer for weight and size of blind.
- I. Hold-Down Brackets and Hooks or Pins: Manufacturer's standard. Provide for blinds on doors.
- J. Colors, Textures, Patterns, and Gloss: As indicated on Interior Finish Schedule on Drawings.

2.3 HORIZONTAL LOUVER BLIND FABRICATION

- A. Product Safety Standard: Fabricate horizontal louver blinds to comply with WCMA A 100.1 including requirements for corded, flexible, looped devices; lead content of components; and warning labels.
- B. Unit Sizes: Fabricate units in sizes to fill window and other openings as follows, measured at 74 deg F:
 1. Between (Inside) Jamb Installation: Width equal to jamb-to-jamb dimension of opening in which blind is installed less 1/4 inch per side or 1/2 inch total, plus or minus 1/8 inch. Length

**NISQUALLY STATE PARK
NEW FULL SERVICE PARK – PHASE 2**

- equal to head-to-sill dimension of opening in which blind is installed less 1/4 inch, plus or minus 1/8 inch.
2. Outside of Jamb Installation: Width and length as indicated, with terminations between blinds of end-to-end installations at centerlines of mullion or other defined vertical separations between openings.
- C. Concealed Components: Noncorrodible or corrosion-resistant-coated materials.
1. Lift-and-Tilt Mechanisms: With permanently lubricated moving parts.
- D. Mounting and Intermediate Brackets: Designed for removal and reinstallation of blind without damaging blind and adjacent surfaces, for supporting blind components, and for bracket positions and blind placement indicated.
- E. Installation Fasteners: No fewer than 2 fasteners per bracket, fabricated from metal noncorrosive to brackets and adjoining construction; type designed for securing to supporting substrate; and supporting blinds and accessories under conditions of normal use.
- F. Color-Coated Finish:
1. Metal: For components exposed to view, apply manufacturer's standard baked finish complying with manufacturer's written instructions for surface preparation including pretreatment, application, baking, and minimum dry film thickness.

PART 3 - EXECUTION

3.1 EXAMINATION

- A. Examine substrates, areas, and conditions, with Installer present, for compliance with requirements for installation tolerances, operational clearances, and other conditions affecting performance of the Work.
- B. Proceed with installation only after unsatisfactory conditions have been corrected.

3.2 INSTALLATION

- A. Install horizontal louver blinds level and plumb, aligned and centered on openings, and aligned with adjacent units according to manufacturer's written instructions.
 1. Locate so exterior slat edges are not closer than 2 inches from interior faces of glass and not closer than 1/2 inch from interior faces of glazing frames through full operating ranges of blinds.
 2. Install mounting and intermediate brackets to prevent deflection of headrails.
 3. Install with clearances that prevent interference with adjacent blinds, adjacent construction, and operating hardware of glazed openings, other window treatments, and similar building components and furnishings.

**NISQUALLY STATE PARK
NEW FULL SERVICE PARK – PHASE 2**

3.3 ADJUSTING

- A. Adjust horizontal louver blinds to operate free of binding or malfunction through full operating ranges.

3.4 CLEANING

- A. Clean horizontal louver blind surfaces after installation according to manufacturer's written instructions.

3.5 PROTECTION

- A. Provide final protection and maintain conditions in a manner acceptable to manufacturer and Installer that ensures that horizontal louver blinds are without damage or deterioration at time of Substantial Completion.
- B. Replace damaged horizontal louver blinds that cannot be repaired in a manner approved by Architect before time of Substantial Completion.

END OF SECTION

**NISQUALLY STATE PARK
NEW FULL SERVICE PARK – PHASE 2**

SECTION 122413 – ROLLER WINDOW SHADES

PART 1 - GENERAL

1.1 SUMMARY

- A. Section Includes:
1. Manually operated roller shades with single rollers.

1.2 ACTION SUBMITTALS

- A. Product Data: For each type of product.
1. Include construction details, material descriptions, dimensions of individual components and profiles, features, finishes, and operating instructions for roller shades.
- B. Shop Drawings: Show fabrication and installation details for roller shades, including shadeband materials, their orientation to rollers, and their seam and batten locations.
- C. Samples for Verification: For each type of roller shade.
1. Shade cloth Material: Not less than 10 inches square.
 - a. Mark interior face of material if applicable.
 2. Roller Shade: Full-size operating unit, not less than 16 inches wide by 36 inches long for each type of roller shade indicated.
 3. Installation Accessories: Full-size unit, not less than 10 inches long.
- D. Product Schedule: For roller shades. Use same designations indicated on Drawings.

1.3 INFORMATIONAL SUBMITTALS

- A. Qualification Data: For Installer.
- B. Product Test Reports: For each type of shadeband material, for tests performed by a qualified testing agency or by manufacturer and witnessed by a qualified testing agency.

1.4 CLOSEOUT SUBMITTALS

- A. Operation and Maintenance Data: For roller shades to include in maintenance manuals.

1.5 MAINTENANCE MATERIAL SUBMITTALS

- A. Furnish extra materials that match products installed and that are packaged with protective covering for storage and identified with labels describing contents.

**NISQUALLY STATE PARK
NEW FULL SERVICE PARK – PHASE 2**

1. Roller Shades: Full-size units equal to 5 percent of quantity installed for each size, color, and shadeband material indicated, but no fewer than 2 units.

1.6 QUALITY ASSURANCE

- A. Manufacturer Qualifications: Manufacturer of products with minimum of 10 years of experience in manufacturing products comparable to those specified in this Section.
- B. Installer Qualifications: Fabricator of products with minimum of 5 years of experience with specified systems and components, trained and certified by the manufacturer in installing products comparable to those specified in this Section.
- C. Mockups:
 1. Mockup Size: Full size unless indicated otherwise.
 - a. Locate mockup where designated by Architect.
 2. Approval of mockups does not constitute approval of deviations from Contract Documents contained in mockups unless Architect specifically approves such deviations in writing.
 3. Subject to compliance with requirements, approved mockups may become part of completed Work if undisturbed at time of Substantial Completion.

1.7 DELIVERY, STORAGE, AND HANDLING

- A. Deliver roller shades in factory packages, marked with manufacturer, product name, and location of installation using same designations indicated on Drawings.

1.8 FIELD CONDITIONS

- A. Environmental Limitations: Do not install roller shades until construction and finish Work in spaces, including painting, is complete and dry and ambient temperature and humidity conditions are maintained at levels indicated for Project when occupied for its intended use.
- B. Field Measurements: Where roller shades are indicated to fit to other construction, verify dimensions of other construction by field measurements before fabrication and indicate measurements on Shop Drawings. Allow clearances for operating hardware of operable glazed units through entire operating range. Notify Architect of installation conditions that vary from Drawings. Coordinate fabrication schedule with construction progress to avoid delaying Work.

1.9 WARRANTY

- A. Special Warranty: Manufacturer agrees to repair or replace components of roller window shades that fail in materials or workmanship within specified warranty period, including chains.
 1. Warranty Periods: From date of Substantial Completion:

**NISQUALLY STATE PARK
NEW FULL SERVICE PARK – PHASE 2**

- a. Shade Cloth and Hardware: 25 years.
- b. Roller Shade Installation: 1 year, not including scaffolding, lifts, or other means to reach inaccessible areas.

PART 2 - PRODUCTS

2.1 MANUFACTURERS

- A. Source Limitations: Obtain roller shades from single source from single manufacturer.

2.2 PERFORMANCE CRITERIA

- A. Components capable of being removed or adjusted without removing mounted shade brackets, or cassette support channel.
- B. Smooth operation raising or lowering shades.

2.3 MANUALLY OPERATED SHADES WITH SINGLE ROLLERS

- A. Manual Operating System: Provide manually operated fabric window shade system complete with mounting brackets, roller tubes, hembars, hardware, and accessories.
 - 1. Product (R.SHADE): Subject to compliance with requirements, provide one of the following:
 - a. Draper, Inc.: Clutch Operated FlexShade CLN.
 - b. Hunter Douglas Architectural Window Coverings: RB 500+.
 - c. MechoShade Systems LLC: Mecho/5.
 - d. Skyco Shading Systems, Inc.: R24 Spring Assist.
- B. Chain-and-Clutch Operating Mechanisms: Continuous-loop bead chain and clutch that stops shade movement when bead chain is released.
 - 1. Shade Type: Single roller.
 - 2. Drop Position: Regular, with fabric falling off roller tube, close to glass.
 - 3. Mounting: Wall or ceiling mounted as indicated on Drawings.
 - 4. Size: As indicated on Drawings.
- C. Clutch Operator: Manufacturer's standard material and design integrated with bracket and brake assembly.
 - 1. Steel mounting bracket with integrated steel brake, clutch, and sprocket assembly that rigidly affixes shade support and user control to building structure fully independent of roller tube components.
 - 2. Permanently lubricated, maintenance-free brake assembly using an oil-impregnated steel hub with wrapped spring clutch.

**NISQUALLY STATE PARK
NEW FULL SERVICE PARK – PHASE 2**

3. Brake designed to withstand minimum pull force of 20 lbs. in stopped position.
 4. Direct drive clutch requires no interstitial gear stages or plastic parts between building structure and clutch ensuring reliable operation across full range of shade sizes.
 5. Maximum shade hanging weight of 50 lbs.
- D. Drive Chain: Continuous loop type.
1. Chain Drive: Offset type that does not cause an increase of friction or pull force when operated up to a 26 degree angle from vertical.
 2. Bead Chains: Type 304 stainless steel, beaded ball chain.
 - a. Loop Length: Full length of roller shade.
 - b. Breaking Strength: 100 lb. minimum.
 - c. Chain-Retainer Type: Chain tensioner, jamb mounted.
 3. Limit Stops: Upper and lower ball stops affixed to chain to maintain consistent shadeband alignment at top and bottom of shade travel across multiple shades, and to help prevent shade damage resulting from unmanaged user control.
- E. Managed Lift Force Hardware: Designed to lift single band shade assemblies:
1. Lifting Force: 10 lbs. maximum pull force to lift shade assemblies with shadeband hanging weight, not including mounting hardware, of up to 50 pounds.
 2. Direct drive clutch with managed lift force manages user pull force while using fewest number of chain pulls to position a shade.
 3. Includes offset drive capability, left/right, front, or back to allow for utilization of blackout channels.
- F. Installation Accessories:
1. Front Fascia: Aluminum extrusion that conceals front and underside of roller and operating mechanism and attaches to roller endcaps without exposed fasteners.
 - a. Shape: L-shaped.
 - b. Height: Manufacturer's standard height required to conceal roller and shadeband assembly when shade is fully open, but not less than 3 inches.
 2. Exposed Headbox: Rectangular, extruded-aluminum enclosure including front fascia, top and back covers, endcaps, and removable bottom closure.
 - a. Height: Manufacturer's standard height required to enclose roller and shadeband assembly when shade is fully open, but not less than 3 inches.
 3. Closure Panel and Wall Clip: Removable aluminum panel designed for installation at bottom of site-constructed ceiling recess or pocket and for snap-in attachment to wall clip without fasteners.
 - a. Closure-Panel Width: As indicated on Drawings.
 - b. Do not include ceiling tile lip.
 4. Installation Accessories Color and Finish: As selected from manufacturer's full range.

**NISQUALLY STATE PARK
NEW FULL SERVICE PARK – PHASE 2**

2.4 COMPONENTS

- A. Mounting Hardware: Manufacturer's standard brackets or endcaps, corrosion-resistant and compatible with roller mounting configuration, roller assembly, operating mechanism, installation accessories, and mounting location and conditions indicated, and able to accommodate shade fabric roll-up sizes and weights.
 - 1. Material: Minimum of 0.12 inch thick plated steel or heavier as required to support 150 percent of full weight of each shade.
 - 2. Single Shade Operation Width: Up to 180 inches dependent on fabric.

- B. Roller Tubes: Extruded aluminum tubes of diameters and wall thicknesses required to accommodate operating mechanisms and weights and widths of shadebands indicated without deflection.
 - 1. Provide with permanently lubricated drive-end assemblies and idle-end assemblies designed to facilitate removal of shadebands for service or replacement without removing roller-tube or affecting roller shade limit adjustments.
 - 2. Single-Roller Mounting Configuration:
 - a. Roller Drive-End Location: As indicated on Drawings.
 - 3. Roller Size: As recommended by manufacturer; selected for suitability for installation conditions, span, and weight of shades.
 - 4. Shadeband-to-Roller Attachment: Removable spline fitting into integral channel in tube.
 - a. Attachment of shadeband with adhesives or staples is not allowed.
 - b. Design shadeband to be removed and replaced without removing roller tube from brackets or inserting spline from side of roller tube.
 - 5. Deflection: Maximum of $L/700$.

- C. Shadeband Bottom Bar (Hembar): Extruded aluminum bottom bar designed to maintain bottom of shade straight and flat.
 - 1. Style: Enclosed in sealed (closed) pocket of shadeband material.
 - 2. Profile: Elliptical.
 - 3. Length: Entire width of shade cloth material.
 - 4. Wood hembars are not acceptable.

2.5 SHADE FABRIC MATERIALS

- A. Physical Properties:
 - 1. Shadeband Material Flame-Resistance Rating: Comply with NFPA 701. Testing by a qualified testing agency. Identify products with appropriate markings of applicable testing agency.
 - 2. Anti-microbial according to ASTM G21.

- B. Light-Filtering Fabric: Woven fabric, stain and fade resistant.
 - 1. Draper, Inc.: Series GreenScreen Evolve 003503.
 - 2. Hunter Douglas: Series Greenscreen Evolve HD3503.
 - 3. MechoShade: Series MechoShade EcoVeil Screens, 1550 series.
 - 4. Mermet USA: Mermet E Screen Shade Fabric: 007503.

**NISQUALLY STATE PARK
NEW FULL SERVICE PARK – PHASE 2**

- 1) Material: PVC-coated fiberglass, thermoplastic olefin, or PVC-free polyester.
 - 2) Thickness: Nominal 0.027 inch.
 - 3) Weight: Nominal 8.4 oz./sq. yd.
 - 4) Style: Basketweave.
 - 5) Performance Requirements:
 - a) Openness Factor: 3 percent.
 - b) UV Blockage: Approximately 97 percent.
 - c) Light Transmittance: 5 percent.
 - d) Light Reflectance: 23 percent.
 - e) Solar Reflectance: 23 percent.
 - f) Solar Absorption: 71 percent.
 - g) Solar Transmittance: 6 percent.
- b. Color: As selected by Architect from manufacturer's full color range.
- C. Product Safety Standard: Fabricate roller shades to comply with WCMA A 100.1, including requirements for flexible, chain-loop devices; lead content of components; and warning labels.
- D. Unit Sizes: Fabricate units in sizes to fill window and other openings as follows:
1. Between (Inside) Jamb Installation: Width equal to jamb-to-jamb dimension of opening in which shade is installed less 1/4 inch per side or 1/2 inch total, plus or minus 1/8 inch. Length equal to head-to-sill or -floor dimension of opening in which shade is installed less 1/4 inch, plus or minus 1/8 inch.
- E. Shadeband Fabrication: Fabricate shadebands without battens or seams to extent possible.

PART 3 - EXECUTION

3.1 EXAMINATION

- A. Examine substrates, areas, and conditions, with Installer present, for compliance with requirements for installation tolerances, operational clearances, and other conditions affecting performance of Work.
- B. Proceed with installation only after unsatisfactory conditions have been corrected.

3.2 INSTALLATION OF ROLLER SHADES

- A. Install roller shades level, plumb, and aligned with adjacent units according to manufacturer's written instructions.
- B. Roller Shade Locations: At exterior windows and where indicated on Drawings.

3.3 REPAIR

- A. Repair damaged roller shades in a manner approved by Architect.

**NISQUALLY STATE PARK
NEW FULL SERVICE PARK – PHASE 2**

- B. Replace damaged roller shades that cannot be repaired before time of Substantial Completion.

3.4 ADJUSTING

- A. Adjust and balance roller shades to operate smoothly, easily, safely, and free from binding or malfunction throughout entire operational range.

3.5 CLEANING

- A. Clean roller shade surfaces, after installation, according to manufacturer's written instructions.

3.6 PROTECTION

- A. Provide final protection and maintain conditions, in a manner acceptable to manufacturer and Installer, that ensure that roller shades are without damage or deterioration at time of Substantial Completion.

END OF SECTION

**NISQUALLY STATE PARK
NEW FULL SERVICE PARK – PHASE 2**

SECTION 123623.13 – PLASTIC-LAMINATE-CLAD COUNTERTOPS

PART 1 - GENERAL

1.1 SUMMARY

A. Section Includes

1. Plastic-laminate-clad countertops.

B. Related Requirements:

1. Section 064100 – Architectural Wood Casework.
2. Division 22 Sections for plumbing fixtures for sinks and plumbing fittings.
3. Division 26 Sections for electrical fixtures and fittings.

1.2 ACTION SUBMITTALS

A. Product Data: For each type of product.

B. Shop Drawings: For plastic-laminate-clad countertops.

1. Include plans, sections, details, and attachments to other Work. Detail fabrication and installation, including field joints.
2. Show locations and sizes of cutouts and holes for items installed in plastic-laminate-clad countertops.

C. Samples for Verification: As follows:

1. Plastic Laminates: For each type, color, pattern, and surface finish required, 8 by 10 inches in size.
2. Fabrication Sample: For each type and profile of countertop required, provide one sample applied to core material with specified edge material applied to one edge.

1.3 INFORMATIONAL SUBMITTALS

A. Qualification Data: For fabricator and Installer.

1.4 CLOSEOUT SUBMITTALS

A. Maintenance Data: For plastic-laminate-clade countertops to include in maintenance manuals.

1. Include Product Data for care products used or recommended by Installer and names, addresses, and telephone numbers of local sources for products.

**NISQUALLY STATE PARK
NEW FULL SERVICE PARK – PHASE 2**

1.5 QUALITY ASSURANCE

- A. Fabricator Qualifications: Shop with minimum 5 years of documented experience that employs skilled workers who custom fabricate products similar to those required for this Project and whose products have a record of successful in-service performance.
 - 1. Shop Certification: AWI's Quality Certification Program accredited participant or WI's Certified Compliance Program licensee.
- B. Installer Qualifications: Fabricator of products and AWI's Quality Certification Program accredited participant or WI's Certified Compliance Program licensee.
- C. Mockups:
 - 1. Build mockup of typical countertop as shown on Drawings.
 - 2. Subject to compliance with requirements, approved mockups may become part of completed Work if undisturbed at time of Substantial Completion.

1.6 DELIVERY, STORAGE, AND HANDLING

- A. Do not deliver countertops until painting and similar operations that could damage countertops have been completed in installation areas.
- B. If countertops must be stored in other than installation areas, store only in areas where environmental conditions comply with requirements specified in "Field Conditions" Article.
- C. Keep surfaces of countertops covered with protective covering during handling and installation.

1.7 FIELD CONDITIONS

- A. Environmental Limitations: Do not deliver or install countertops until building is enclosed, wet Work is complete, and HVAC system is operating and maintaining temperature and relative humidity at levels planned for building occupants during remainder of construction period.
- B. Do not install casework materials that are wet, moisture damaged, or mold damaged.
 - 1. Indications that materials are wet or moisture damaged include discoloration, sagging, or irregular shape.
 - 2. Indications that materials are mold damaged include fuzzy or splotchy surface contamination and discoloration.
- C. Established Dimensions: Where countertops are indicated to fit to other construction, establish dimensions for areas where woodwork is to fit. Provide allowance for trimming at site, and coordinate construction to ensure that actual dimensions correspond to established dimensions.

**NISQUALLY STATE PARK
NEW FULL SERVICE PARK – PHASE 2**

PART 2 - PRODUCTS

2.1 FABRICATORS

- A. Manufacturers: Subject to compliance with requirements, provide products by one of the following:
 - 1. Anderson Clark Interiors.
 - 2. Cascade Casework Corp.
 - 3. Fremont Millwork Co.
 - 4. McCarthy Manufacturing.
 - 5. Pro Shop Millwork & Design.

- B. Source Limitations: Firm engaged to assume undivided responsibility for production of plastic-laminate-clad countertops shall also take responsibility for the following:
 - 1. Section 062023 – Interior Finish Carpentry.
 - 2. Section 064100 – Architectural Wood Casework.
 - 3. Section 064216 – Flush Wood Paneling.

2.2 PLASTIC-LAMINATE-CLAD COUNTERTOPS

- A. Quality Standard: Unless otherwise indicated, comply with AWI's "Architectural Woodwork Standards" or WI's "North American Architectural Woodwork Standards" for grades of architectural cabinets indicated for construction, finishes, installation, and other requirements.
 - 1. Provide labels and certificates from AWI or WI certification program indicating that woodwork complies with requirements of grades specified.
 - 2. Contract Documents may contain requirements that are more stringent than referenced woodwork quality standard. Comply with requirements of Contract Documents in addition to those of referenced quality standard.

- B. Architectural Woodwork Standards Grade: Custom.

- C. High-Pressure Decorative Laminate (HDPL): ISO 4586-3, Grade as required by woodwork quality standard.
 - 1. Manufacturers: Subject to compliance with requirements, provide products by one of the following:
 - a. Forbo Arborite.
 - b. Formica Corporation.
 - c. Nevamar; a Panolam Industries International, Inc. brand.
 - d. Pionite; a Panolam Industries International, Inc. brand.
 - e. Wilsonart LLC; Decorative Plastic Laminates.

 - 2. Colors, Patterns, and Finishes: As selected by Architect from manufacturer's full range.:

- D. Edge Treatment: Same as laminate cladding on horizontal surfaces.

**NISQUALLY STATE PARK
NEW FULL SERVICE PARK – PHASE 2**

- E. Core Material: MDF.
- F. Core Material at Sinks: MDF made with exterior glue.
- G. Core Thickness: 3/4 inch or as indicated on Drawings.
 - 1. Build up countertop thickness to 1-1/2 inches at front, back, and ends with additional layers of core material laminated to top where indicated.
- H. Backer Sheet: Provide plastic-laminate backer sheet, ISO 4586-3, Grade BKL, on underside of countertop substrate.
- I. Paper Backing: Provide paper backing on underside of countertop substrate.

2.3 WOOD MATERIALS

- A. Composite Wood and Agrifiber Products: Provide materials that comply with requirements of referenced quality standard for each type of countertop and quality grade specified unless otherwise indicated.
 - 1. Medium-Density Fiberboard (MDF): ANSI A208.2, Grade 130.
 - a. Products: Subject to compliance with requirements, provide one of the following:
 - 1) ampine; Div. of Timber Products Company: Apex MDF.
 - 2) ARAUCO North America: Trupan Standard MDF.
 - 3) Del-Tin Fiber, LLC: Solidium Ultra MDF.
 - 4) Georgia-Pacific Wood Products LLC: UltraStock Premium MDF.
 - 5) Roseburg Forest Products Co.: Medite II.
 - 6) Timber Products Company: Masisa Ultralight MDF.
 - 7) West Fraser Timber Co., Ltd.: WestPine EcoGold MDF.
 - 8) Weyerhaeuser Company: Super-Refined MDF2.
 - 2. Softwood Plywood: DOC PS 1, medium-density overlay.

2.4 ACCESSORIES

- A. Mounting Brackets: Concealed brackets for mounting countertops and vanities are specified in Section 055000 - Metal Fabrications.
- B. Wire Management Grommet Set: Extruded aluminum grommets and matching aluminum covers with slot for wire passage.
 - 1. GROM-1 Basis-of-Design Product: Subject to compliance with requirements, provide the following:
 - a. Richelieu: Product 2134278890.
 - b. Approved substitution.

**NISQUALLY STATE PARK
NEW FULL SERVICE PARK – PHASE 2**

2. GROM-2 Basis-of-Design Product: Subject to compliance with requirements, provide the following:
 - a. Richelieu: Product 2135206690.
 - b. Approved substitution.
3. Wire Slot: Provide with black brush seal.
4. Cover: Provide with smooth closing function.
5. Size (GROM-1):
 - a. Size: 12-5/8 inch wide, 4-11/32 inch width.
 - b. Finish: Black.
6. Size (GROM-2):
 - a. Size: 9-3/16 inch wide, 4-23/32 inch width.
 - b. Finish: Black.
7. Applications: Mount in countertops where indicated on Drawings. Refer to the following:
 - a. Section 123623.13 Plastic-Laminate-Clad Countertops.

2.5 MISCELLANEOUS MATERIALS

- A. Adhesives for Bonding Plastic Laminate: Type as selected by fabricator to comply with requirements.
 1. Type II Water-Resistant Type: Use for general adhesive.
 2. Type I, Waterproof Type: Use for countertops with sinks.
 3. Adhesive for Bonding Edges: Hot-melt adhesive or adhesive specified above for faces.
 4. Where through-color laminates are scheduled, use adhesive that will not affect laminate finish.
- B. Installation Adhesive: Product recommended by fabricator for each substrate for secure anchorage.

2.6 COUNTERTOP FABRICATION

- A. Fabricate countertops according to quartz agglomerate manufacturer's written instructions and to AWI's "Architectural Woodwork Standards" or WI's "North American Architectural Woodwork Standards."
 1. Grade: Custom.
- B. Fabricate countertops to dimensions, profiles, and details indicated. Provide front and end overhang of 1 inch over base cabinets. Ease edges to radius indicated for the following:
- C. Complete fabrication, including assembly, to maximum extent possible before shipment to Project site. Disassemble components only as necessary for shipment and installation. Where necessary for fitting at site, provide ample allowance for scribing, trimming, and fitting.

**NISQUALLY STATE PARK
NEW FULL SERVICE PARK – PHASE 2**

1. Notify Architect 7 days in advance of dates and times countertop fabrication will be complete.
 2. Trial fit assemblies at fabrication shop that cannot be shipped completely assembled. Install dowels, screws, bolted connectors, and other fastening devices that can be removed after trial fitting. Verify that various parts fit as intended, and check measurements of assemblies against field measurements before disassembling for shipment.
- D. Shop cut openings to maximum extent possible to receive appliances, plumbing fixtures, electrical Work, and similar items.
1. Locate openings accurately, and use templates or roughing-in diagrams to produce accurately sized and shaped openings.
 2. Sand edges of cutouts to remove splinters and burrs.
 3. Seal edges of cutouts by saturating with varnish.

PART 3 - EXECUTION

3.1 PREPARATION

- A. Before installation, condition countertops to average prevailing humidity conditions in installation areas.
- B. Before installing countertops, examine shop-fabricated Work for completion and complete Work as required, including removal of packing.

3.2 INSTALLATION OF COUNTERTOPS

- A. Grade: Install countertops to comply with same grade as item to be installed.
- B. Assemble countertops and complete fabrication at Project site to extent that it was not completed in shop.
 1. Provide cutouts for appliances, plumbing fixtures, electrical Work, and similar items. Locate openings accurately, and use templates or roughing-in diagrams to produce accurately sized and shaped openings. Sand edges of cutouts to remove splinters and burrs.
 2. Seal edges of cutouts by saturating with varnish.
- C. Field Jointing: Where possible, make in the same manner as shop jointing, using dowels, splines, adhesives, and fasteners recommended by manufacturer. Prepare edges to be joined in shop so Project-site processing of top and edge surfaces is not required. Locate field joints where shown on Shop Drawings.
 1. Secure field joints in countertops with concealed clamping devices located within 6 inches of front and back edges and at intervals not exceeding 24 inches. Tighten according to manufacturer's written instructions to exert a constant, heavy-clamping pressure at joints.
- D. Scribe and cut countertops to fit adjoining Work, refinish cut surfaces, and repair damaged finish at cuts.

**NISQUALLY STATE PARK
NEW FULL SERVICE PARK – PHASE 2**

- E. Countertop Installation: Anchor securely by screwing through corner blocks of base cabinets or other supports into underside of countertop.
 - 1. Install countertops level and true in line. Use concealed shims as required to maintain not more than a 1/8 inch in 96 inches variation from a straight, level plane.
 - 2. Secure backsplashes to tops with concealed metal brackets at 16 inches on center and to walls with adhesive.
 - 3. Seal joints between countertop and backsplash, if any, and joints where countertop and backsplash abut walls with mildew-resistant silicone sealant or another permanently elastic sealing compound recommended by countertop material manufacturer.

3.3 ADJUSTING

- A. Repair damaged and defective countertops, where possible, to eliminate functional and visual defects. Where not possible to repair, replace countertops. Adjust joinery for uniform appearance.

3.4 CLEANING

- A. Clean countertops on exposed and semiexposed surfaces.
- B. Protection: Provide Kraft paper or other suitable covering over countertop surfaces, taped to underside of countertop at a minimum of 48 inches on center. Remove protection at Substantial Completion.

END OF SECTION

**NISQUALLY STATE PARK
NEW FULL SERVICE PARK – PHASE 2**

SECTION 133470 – PREFABRICATED RESTROOM

PART 1 - GENERAL

1.1 SCOPE

- A. This specification covers the construction and placing of precast Cascadian vault toilet buildings as produced by CXT® Incorporated or approved vendor.

1.2 SPECIFICATIONS

- A. ASTM C33 Concrete Aggregates
- B. ASTM C39 Method of Test for Compressive Strength of Cylindrical Concrete Specimens
- C. ASTM C94 Standard Specification for Ready-Mixed Concrete
- D. ASTM C143 Method of Test for Slump of Concrete
- E. ASTM C150 Standard Specification for Portland Cement
- F. ASTM C172 Standard Practice for Sampling Freshly Mixed Concrete
- G. ASTM A185 Standard Specification for Steel Welded Wire Reinforcement, Plain, or Concrete
- H. ASTM C192 Method of Making and Curing Test Specimens in the Laboratory
- I. ASTM C231 Standard Test Method for Air Content of Freshly Mixed Concrete by the Pressure Method
- J. ASTM C309 Standard Specifications for Liquid Membrane-Forming Compounds for Curing Concrete
- K. ASTM C494 Standard Specification for Chemical Admixtures for Concrete
- L. ASTM A615 Standard Specification for Deformed and Plain Carbon-Steel bars for Concrete Reinforcement
- M. ASTM C618 Standard Specification for Coal Fly Ash and Raw or Calcined Natural Pozzolan for Use in Concrete
- N. ASTM C979 Standard Specification for Pigments for Integrally Colored Concrete
- O. ASTM D1557 Standard Test Methods for Laboratory Compaction Characteristics of Soil Using Modified Effort
- P. ACI 211.1 Standard Practice for Selecting Proportions for Normal, Heavyweight, and Mass Concrete

**NISQUALLY STATE PARK
NEW FULL SERVICE PARK – PHASE 2**

- Q. ACI 306 Cold Weather Concreting
- R. ACI 318 Building Code Requirements Structural Concrete and Commentary (includes Errata)
- S. PCI MNL 116 Quality Control for Plants and Production of Precast Prestressed Concrete Products

1.3 MANUFACTURER CRITERIA

- A. The manufacturer supplying the requested precast concrete vault facility must meet the following:
 - 1. Manufacturer must be ISO 9001 certified at the time of bid.
 - 2. Manufacturing plant must be PCI certified at the time of bid.
 - 3. Manufacturer must not have defaulted on any contract within the last five (5) years.
 - 4. Manufacturer must provide stamped, engineered drawings prior to acceptance.
 - 5. Manufacturer must be pre-approved prior to bidding.
 - 6. Manufacturer must show four (4) examples of Sweet Smelling Technology designed precast concrete vault toilet facilities produced, installed, and in use as an example of their ability to perform on this contract.
- B. Manufacture shall provide a one-year warranty.
- C. UL 752 Bullet Resistance on 4” thick concrete samples.

Manufacturer meeting these criteria is:

CXT Incorporated
6701 E. Flamingo Avenue, Building 300
Nampa, ID 83687
Phone 800-696-5766

1.4 DESIGN CRITERIA

- A. Vault buildings shall be designed to individually meet the following criteria.
 - 1. Roof Snow Load: Vault buildings are designed to withstand a 350 pounds per square foot snow load.
 - 2. Floor Load: Vault buildings are designed to withstand 400 pounds per square foot floor load.
 - 3. Wind Load: Vault buildings will withstand the effects of 150 miles per hour (3-second gust) wind exposure C.
 - 4. Earthquake: Vault buildings will withstand the effects of a seismic design category E earthquake.
 - 5. Sweet Smelling Technology (SST): Vault buildings incorporate design aspects of SST as outlined by Briar Cook for the U.S. Forest Service.
 - a. All wall to floor interior surface seams shall have a minimum 1” radius coving made of high strength grout.
 - b. The vault shall have a bottom slope of 1” per foot from under the toilet riser out to the outside cleanout area.

**NISQUALLY STATE PARK
NEW FULL SERVICE PARK – PHASE 2**

- c. The vault shall have a 24” diameter (minimum) lightweight manhole cover installed to the rear or side of the building.
 - 1) The manhole cover should be raised, with the surrounding concrete sloped away using a minimum slope of 1/2” per foot.
 - d. The depth of the vault shall be no deeper than 4½’ to 5’.
 - e. A 12” diameter round pipe will be installed to vent the vault and the pipe shall be raised a minimum of 3’ above the highest point of the roof.
 - 1) Vent pipe shall be straight up from the vault.
 - f. There shall be only one vent opening in the building and it shall be placed only on one side of the building (the side that the wind blows against).
6. Additional Design Standards
- a. Single vault buildings are an all-concrete design with a minimum 7/12 roof pitch.
 - b. Vault buildings shall have a minimum 4” wall, 4½” roof, and 5” floor thickness.
 - c. Vault buildings have a one-piece floor unit to prevent panels that migrate in different directions during periods of freeze/thaw stress.
 - d. Vault buildings have a one-piece full length and width vault unit to support the building, screen area, and snow loads evenly.
 - e. All Cascadian Vault Restrooms shall be Left Hand Floor Plan models. Upper walls shall be Board & Batt, Lower Walls shall be horizontal lap siding. Roof shall be Cedar Shakes texture. All Exterior Color shall be Amber Rose. Interior Color shall be white.

1.5 MATERIALS

A. Concrete – General

- 1. The concrete mix design is designed to ACI 211.1 to produce concrete of good workability.
- 2. Concrete will contain a minimum of 675 pounds of cementitious material per yard. Cement is a low alkali type I/II or III conforming to ASTM C-150.
- 3. Coarse aggregates used in the concrete mix design will conform to ASTM C33 with the designated size of coarse aggregate #67.
- 4. Maximum water/cement ratio will not exceed .45.
- 5. Air-entraining admixtures will conform to ASTM C260. Water reducing admixtures will conform to ASTM C494, Type A.
- 6. If Self Compacting Concrete (SCC) is used, it must conform to ASTM C1611.

B. Concrete – Cold Weather

- 1. Cold weather concrete placement is in accordance with ACI 306.
- 2. Concrete will not be placed if ambient temperature is expected to be below 35°F during the curing period unless heat is readily available to maintain the temperature of the concrete at least 50°F.
- 3. Materials containing frost or lumps of frozen materials will not be used.

**NISQUALLY STATE PARK
NEW FULL SERVICE PARK – PHASE 2**

C. Concrete – Hot Weather

1. The temperature of the concrete will not exceed 90°F at the time of placement. When the ambient reaches 90°F the concrete is protected with moist covering.

D. Concrete Reinforcement

1. All reinforcing steel will conform to ASTM A615. All welded wire fabric will conform to ASTM A185.
2. All reinforcement is new, free of dirt, oil, paint, grease, loose mill scale and loose or thick rust when placed.
3. Details not shown on drawings or specified are to ACI318.
4. Steel reinforcement is centered in the cross-sectional area of the walls and will have at least 1¼” of cover on the under surface of the floor.
5. The maximum allowable variation for center-center spacing of reinforcing steel is ½”.
6. Full lengths of reinforcing steel are used when possible. When splices are necessary on long runs, splices are alternated from opposite sides of the components for adjacent steel bars.
 - a. Lap bars under #4 a minimum of 12” bar diameters.
 - b. Lap bars larger than #4 a minimum of 24” bar diameters.
7. Reinforcing bars are bent cold. No bars partially embedded in concrete are field bent unless approved by the customer.

E. Caulking, Grout, Adhesive and Sealer

1. Caulking service temperatures from -40°F to +194°F.
2. Interior and exterior joints are caulked with a paintable polyurethane sealant.
3. Grout is a non-shrink type and are painted to match the color of surrounding concrete as nearly as possible.
4. Cement base coating is formulated with a very fine aggregate system and is a built-in bonding agent.

F. Dead Bolt

1. Certified ANSI/BHMA A156.5-2001 Grade 1.
2. Heavy duty tamper resistant.
3. 2¾” backset.
4. U.S. 26D finish.

G. Doors – Steel

1. Doors are flush panel type 1¾” thick, minimum 16-gauge galvanized steel, top painted with DTM ALKYD.
2. Door frames are knockdown or welded type, single rabbet, minimum 16-gauge prime coated steel top painted with DTM ALKYD, width to suit wall thickness.
3. Three (3) rubber door silencers are provided on latch side of frame.

**NISQUALLY STATE PARK
NEW FULL SERVICE PARK – PHASE 2**

- H. Door Hinges
 - 1. Three (3) per door with dull chrome plating 4½” x 4½”, adjustable tension, and automatic closing for each door.
- I. Doorstop
 - 1. Dome style stop meeting ANSI 156.16.
- J. Door Sweep
 - 1. Provided at the bottom of door with an adjustable brush.
- K. Double Coat Hook
 - 1. 16-gauge (1.5mm), type 304 stainless steel.
 - 2. Formed construction with a satin finish and have ¾” x 7/8” nail in anchor.
 - 3. Upper hook extends at least 2½” from the wall.
 - 4. Lower hook will extend at least 1¼” from the wall.
- L. Grab Bars
 - 1. 18-gauge, type 304 stainless steel with 1½” clearance.
 - 2. Able to withstand 300-pound top loading.
- M. Lockset
 - 1. Meets ANSI A156.2 Series 4000, Grade 1 cylindrical lockset for exterior door.
 - 2. Lever handle both inside and out.
 - 3. Either handle operates latch unless outside handle is locked by inside push-button.
 - 4. Push-button will automatically release when inside lever handle is turned or door is closed.
 - 5. Emergency slot on exterior so door can be unlocked from the outside with a coin, screwdriver, etc.
 - 6. Inside lever always active.
 - 7. U.S. 26D finish.
- N. Paint
 - 1. All paints and materials will conform to all federal specifications or be similar “top-of-the-line-components.”
 - 2. Paints will not contain more than .06% by weight of lead.
 - 3. Type of paints for toilets.
 - a. Inside concrete surfaces.
 - 1) Interior floors – chemical resistant urethane. The color is gray.
 - 2) Interior walls and ceilings – modified acrylic, water repellent penetrating stain. The color is white followed by a clear acrylic anti-graffiti sealer.

**NISQUALLY STATE PARK
NEW FULL SERVICE PARK – PHASE 2**

- b. Exterior concrete surfaces.
 - 1) Exterior slab – clear sealer.
 - 2) Exterior walls and roof – water repellent penetrating stain in the same color as the walls or roof followed by a clear acrylic anti-graffiti sealer.
- c. Metal surfaces (both inside and out).
 - 1) DTM ALKYD.

O. Riser

- 1. Meets ADA standards.
- 2. Molded one-piece HDPE polyethylene.
- 3. Smooth surface and have high impact resistance at extremely cold temperatures.

P. Sealers and Curing Compounds

- 1. Curing compounds, if used, are colorless, complying with ASTM C309, type I or 1-D.
- 2. Weatherproofing sealer for exterior of building are a clear water repellent penetrating sealer.

Q. Signs

- 1. Signs to have raised pictograms, letters, and braille to meet ADA.
- 2. Interior to have “No Trash in Vault” sign.
- 3. All signs inset a minimum of $\frac{3}{4}$ ” into wall with 45-degree bevel.
- 4. All signs to be anchored into concrete with $\frac{1}{4}$ ” x $\frac{3}{4}$ ” concrete anchor nails.

R. Toilet Paper Dispenser

- 1. Constructed of $\frac{1}{4}$ ” thick, type 304 stainless steel.
- 2. Holds three (3) standard rolls of toilet paper.
- 3. Fastening system able to withstand 300-pound top loading.

S. Polyethylene Vault Liner

- 1. Made of a Roto molded 8460 polyethylene.
- 2. Holds up to 1,000 gallons of waste or 15,000 uses per vault.
- 3. Minimum thickness .100.
- 4. Molded dovetail embeds to attach the liner to concrete walls of the vault.
- 5. Welded two (2) C-channels to attach the liner to the bottom of the vault.

T. Vent Stack

- 1. Minimum 12” in diameter and a minimum 3’ higher than the roof peak.

U. Wall Vent

- 1. Vent cover is 14-gauge, type 304 stainless steel painted with DTM and anchored into the concrete wall with high strength anti-rust tap con fasteners.

**NISQUALLY STATE PARK
NEW FULL SERVICE PARK – PHASE 2**

2. Vent louver frame and louvers are non-vision, .1” extruded, aluminum jet coat finish.
3. Vent comes with insect screen.
4. Cover to be recessed a minimum ¾” on exterior walls with a 45-degree bevel. Interior to be flush mounted. Wall vent will not protrude from the wall.

V. Windows and Vault Cleanout Cover

1. Windows and cleanout cover frames are constructed from steel.
2. Window glazing is ⅜” thick translucent pebble finished mar-resistant Lexan.
3. Plate for vault cleanout cover is ¼” thick diamond plate steel.
4. Lid is hinged and configured so that it can be locked with a padlock. A gasket is provided around the entire perimeter of the lid to provide an airtight seal.
5. Windows to have ¾” recess with 45-degree bevel.
6. Windows frames to have vandal resistant fasteners.

1.6 MANUFACTURE

A. Mixing and Delivery of Concrete

1. Mixing and delivery of concrete are in accordance with ASTM C94, Section 12.6 through 12.9.

B. Placing and Consolidating Concrete

1. Except for SCC, concrete is consolidated by the use of mechanical vibrators. Vibration are sufficient to accomplish compaction but not to the point that segregation occurs.

C. Finishing Concrete

1. Interior floor and exterior slabs are floated and troweled.
2. All exterior building walls and exterior screen walls are any one of the available textures.
3. All exterior surfaces of the roof panels are cast to simulate any one of the available textures. The underside of the overhang will have a smooth finish.

D. Cracks and Patching

1. Cracks in concrete components which are judged to affect the structural integrity of the building are rejected.
2. Small holes, depressions, and air voids are patched with a suitable material. The patch will match the finish and texture of the surrounding surface.
3. Patching will not be allowed on defective areas if the structural integrity of the building is affected.

E. Curing and Hardening Concrete

1. Concrete surfaces will not be allowed to dry out from exposure to hot, dry weather during initial curing period.

**NISQUALLY STATE PARK
NEW FULL SERVICE PARK – PHASE 2**

1.7 FINISHING AND FABRICATION

A. Structural Joints

1. Wall components are joined together with two (2) welded plate pairs at each joint.
 - a. Each weld plate is 6” long and located one (1) pair in the top quarter and one (1) pair in the bottom quarter of the seam.
 - b. Weld plates are anchored into the concrete panel and welded together with a continuous weld.
 - c. Inside seams are a paintable caulk.
 - d. Outside seams will use a caulk in a coordinating building color or clear.
2. Walls and roof are joined with weld plates, 3" x 6" at each building corner.
3. The joint between the floor slab and walls are joined with a grout mixture on the inside, a matching colored caulk on the outside and two (2) weld plates 6” long per wall.

B. Painting/Staining

1. An appropriate curing time is allowed before paint is applied to concrete.
2. Some applications may require acid etching. A 30% solution of hydrochloric acid are used, flushed with water, and allowed to thoroughly air dry.
3. Painting will not be done outside in cold, frosty, or damp weather.
4. Painting will not be done outside in winter unless the temperature is 50°F or higher.
5. Painting will not be done in dusty areas.
6. All surface voids are filled prior to painting.
7. Schedule of finishes.
 - a. Inside concrete surfaces.
 - 1) Inside floors – one (1) coat of 1-part water based chemical resistant urethane.
 - 2) Interior walls and ceilings – two (2) coats of a modified acrylic, water repellent penetrating stain, followed by one (1) coat of clear sealer.
 - b. Exterior concrete surfaces.
 - 1) Exterior walls – two (2) coats of water repellent penetrating stain in the same color as the walls or roof followed by one (1) coat of clear acrylic anti-graffiti sealer.
 - c. Metal surfaces (both inside and out).
 - 1) Two (2) coats of DTM ALKYD.

1.8 TESTING

- A. Testing will only be performed by qualified individuals who have been certified ACI Technician Grade 1.
- B. Sampling is in accordance with ASTM C172.

**NISQUALLY STATE PARK
NEW FULL SERVICE PARK – PHASE 2**

- C. The following tests are performed on concrete used in the manufacture of toilets. All testing is performed in the CXT (PCI certified) laboratories.
 - 1. Air content – checked per ASTM C231 on the first batch of concrete. The air content is in the range of 5.0% +/- 1.5%.
 - 2. Compressive strength of the cylinders – tested to ASTM C39.
 - a. Two (2) are tested at release (minimum strength of 2500 psi).
 - b. One (1) is tested at seven (7) days (minimum strength of 4500 psi).
 - c. Two (2) are tested at 28 days (minimum strength of 5000 psi).
- D. A copy of all test reports are available to the customer as soon as 28-day test results are available.

1.9 INSTALLATION

- A. Scope of Work
 - 1. Work specified under this section includes excavation, backfill and placement of precast concrete vault toilet.
- B. Materials
 - 1. Bedding material to be sand or 3/8" minus crushed or screened aggregate.
 - 2. Caulking between vault and toilet floor to be 1" x 1" Butyl tape designed specifically to bond precast concrete to precast concrete.
- C. Location – it is the responsibility of the Contractor to:
 - 1. Provide exact location by stakes or other approved method.
 - 2. Provide clear and level site free of overhead and/or underground obstructions.
 - 3. Provide access to the site for truck delivery and sufficient area for the crane to install and the equipment to perform the contract requirements.
- D. Access to Site
 - 1. Delivery to site made on normal highway trucks and trailers.
 - 2. If, at the time of delivery, conditions of access are hazardous or unsuitable for truck and equipment due to weather, physical constraints, roadway width or grade, Contractor shall delay delivery and installation till favorable conditions allow for installation.
- E. Excavation and Elevation
 - 1. Comply with all applicable OSHA standards for excavation.
 - 2. Excavate for the installation of the toilet vault to a depth that will allow the structure site to be free draining after installation is completed. Allow for a 2" leveling course beneath the toilet vault. Stockpile topsoil in a separate pile at sites.
 - 3. Finish floor elevation is 4-6" above natural grade measured at the front (entrance) of the exterior slab unless otherwise approved by the customer. Ideally, the back of the building should be slightly higher to allow water to freely drain out of the toilet rooms. The

**NISQUALLY STATE PARK
NEW FULL SERVICE PARK – PHASE 2**

Contractor will install buildings at these sites with the floor elevation within a plus or minus 0.05' of the specified floor elevation.

4. No excavation is to be left open more than seven (7) days unless otherwise approved by the customer.
5. All excavations left open overnight are fenced with wire mesh or plastic mesh fence secured to steel posts all around the excavation.
 - a. The bottom of the fence will generally follow the contour of the ground.
 - b. Maximum spacing of the steel posts is 10'.
 - c. Minimum height of the fence is 36".

F. Backfill and Compaction

1. Compact the natural ground at the bottom of the vault excavation with a minimum of three (3) passes with a whacker-type mechanical compactor or equivalent approved by the customer.
2. Install sand or aggregate bedding material for leveling course if needed. Compact leveling course with one (1) pass with a whacker-type mechanical tamper or equivalent approved by the customer. Grade leveling course so there are no high spots in the middle of the vault bottom. Compact with a second pass with a whacker or approved equivalent tamper.
3. Set vault in place and check for level or appropriate scope. Backfill around structure. Use excavated material for backfill except those rocks larger than 6" in maximum dimension shall not be placed within 6" of the exterior vault walls.
4. Fill, adjacent to the building entry, will have excavated material placed in 8" loose lifts and compacted with a minimum of two (2) passes with a whacker-type mechanical compactor or equivalent approved by the customer.

G. Finish Grading

1. Spread excess excavated material from the vault around structure. Intended final grade is flush with the top of the front slab. Allow for placement of topsoil to reach that grade. Grade backfill away from structure at maximum slope of 5% unless otherwise approved by the customer.
2. Spread stockpiled topsoil as final layer after rough grading is completed. Areas disturbed by excavation, backfilling and stockpiling of excavated materials are hand raked to remove exposed rocks over 1" in maximum dimension.
3. Oversized rocks removed from the surface shall be disposed of in a designated Disposal Area.

H. Exhaust Pipe Installation

1. After exhaust pipe is installed, seal around pipe at top and underside of roof with polyurethane caulk. Seal around pipe at top of slab are accomplished by using polyurethane caulk.

**NISQUALLY STATE PARK
NEW FULL SERVICE PARK – PHASE 2**

1.10 WARRANTY

Contractor shall provide a one (1) year warranty on all concrete components and installation.

PART 2 – PRODUCTS (NOT USED)

PART 3 – EXECUTION (NOT USED)

END OF SECTION

**NISQUALLY STATE PARK
NEW FULL SERVICE PARK – PHASE 2**

SECTION 133700 - BOARDWALK

PART 1 - GENERAL

1.1 SCOPE OF WORK

- A. Provide material, equipment, labor, and related items necessary to complete the work shown on the Drawings and/or as specified in the Specifications. The items of work to be performed shall include but are not limited to:
 - 1. Construction of the Boardwalk, Railings, Gate, Ladder, and Overlook Decks.

1.2 REFERENCES

- A. American Society of Testing and Materials (ASTM).
- B. American Institute of Timber Construction (AITC).
- C. West Coast Lumber Inspection Bureau (WCLIB).
- D. American Wood Protection Association (AWPA).

1.3 RELATED WORK

- A. Coordinate related work specified in other parts of the Project Specifications, including, but not limited to the following:
 - 1. Section 015713 – Temporary Erosion and Sedimentation Control
 - 2. Section 051200 – Structural Steel Framing
 - 3. Section 055000 – Metal Fabrications
 - 4. Section 060573 – Wood Treatment
 - 5. Section 061316 – Pole Construction
 - 6. Section 067413 – Ecograte
 - 7. Section 137000 – Diamond Pier Foundations
 - 8. Section 311100 – Clearing and Grubbing

1.4 SUBMITTALS

- A. Submit supplier certificate stating compliance with the requirements and specifications of this Section and compliance with minimum allowable unit stresses.
- B. Product Data:
 - 1. Manufacturer's data sheets on each product to be used.
 - 2. Preparation instructions and recommendations.
 - 3. Storage and handling requirements and recommendations.

**NISQUALLY STATE PARK
NEW FULL SERVICE PARK – PHASE 2**

- C. Shop Drawings: Contractor shall include details of materials, construction, and finish. Include cross sections of the Boardwalk, railings, and overlooks prior to construction. Include relationship with adjacent construction.

1.5 QUALITY ASSURANCE

- A. Manufacturer Qualifications: Company specializing in manufacturing products specified in this section with a minimum of five years documented experience.
- B. Installer Qualifications: Company specializing in performing Work of this section with minimum five years documented experience with projects of similar scope and complexity.
- C. Source Limitations: Provide each type of product from a single manufacturing source to ensure uniformity.

1.6 DELIVERY, STORAGE AND HANDLING

- A. Where required, all materials shall be protected from the weather by suitable covering. Coordinate scheduled delivery of all wood materials to avoid extended on-site storage and to avoid delaying the work. Handle lumber carefully without sudden dropping, breaking of the outer fibers, bruising, or penetrating the surface with tools. Handle lumber with rope slings; no cant dogs, peaveys, hooks, or pike poles shall be used. Hardware received at the site shall be protected from corrosion by storing under cover. Storing and handling shall conform to AWP M4.

PART 2 - PRODUCTS

2.1 WOOD TREATMENT

- A. All dimensional lumber used in construction of the Boardwalk shall be treated per Section 060573 Wood Treatment.

2.2 BOARDWALK FRAMING POSTS, BEAMS, JOISTS, BRACING, AND DECKING

- A. Posts, handrail/panel framing used in construction of Boardwalk shall be No. 1 and Better Hem/Fir.
- B. Beams, Joists, and Bracing used in construction of the Boardwalk framing shall be No. 2 Structural and Better Hem/Fir.
- C. Posts used in Boardwalk framing shall be treated with Preserve CA-C (Copper Azole) rated for ground contact use category UC4A.
- D. Beams, Joists, and Bracing used in construction of the Boardwalk framing shall be treated with Preserve CA-C (Copper Azole) for above ground use category UC3B.

**NISQUALLY STATE PARK
NEW FULL SERVICE PARK – PHASE 2**

- E. Posts, Beams, and Joist sizes shown on plan are nominal and refer to stock dimensional products. Posts, Beams, and Joists shall be S4S.
- F. Decking shall be Fibergrate Composite Structure's Ecograte 62, as specified in Section 067413 Ecograte or approved equal – color: Brown.

2.3 FOUNDATIONS

- A. Diamond Pier Foundation as specified in Section 137000 Diamond Pier Foundation.

2.4 BOARDWALK & RAMP HANDRAIL

- A. The 4x6 Guardrail Post shall be No. 1 Structural and better Hem-Fir.
- B. The 2x6 Top Rail shall be No. 1 Structural and better Hem-Fir.
- C. The 2x6 Bottom Rail shall be No. 2 Structural and better Hem-Fir.
- D. All wooden members shall be treated with Preserve CA-C (Copper Azole) for above ground use category UC3B.
- E. Wood sizes shown on plan are nominal and refer to stock dimensional products.
- F. Pipe Handrails along the ramp shall use 2" O.D. galvanized steel pipe per Section 055200 Pipe Handrail.

2.5 OVERLOOK HANDRAIL

- A. The 2x10 Overlook Handrail shall be Select Structural Hem Fir.
- B. The 4x6 Guardrail Post shall be No. 2 Structural and Better Hem-Fir.
- C. The 2x6 Top Rail shall be No. 2 Structural and better Hem-Fir.
- D. The 2x6 Bottom Rail shall be No. 2 Structural and Better Hem-Fir.
- E. All wooden members shall be treated with Preserve CA-C (Copper Azole) for above ground use category UC3B.
- F. Wood sizes shown on Plans are nominal and refer to stock dimensional products.

2.6 RAILING PANELS

- A. Panels at the Boardwalk and Boardwalk ramps shall be 3x3 Welded Wire Mesh, 6-1/4 gauge, galvanized finish, or approved equal.
- B. Panels for Overlooks 2 and 3 Handrails shall be Owner Furnished and Contractor Installed.

**NISQUALLY STATE PARK
NEW FULL SERVICE PARK – PHASE 2**

2.7 GATE & LADDER

- A. All wooden members used in construction of the gate and ladder shall be No. 2 Structural and Better Hem/Fir.
- B. 4x4 Posts that are anchored to the concrete pier blocks, for construction of the ladder, shall be treated with Preserve CA-C (Copper Azole) for ground contact, use category UC4A.
- C. All wooden members used in construction of the ladder, except for the 4x4 Posts anchored to the concrete pier blocks, shall be treated with Preserve CA-C (Copper Azole) for above ground, use category UC3B.
- D. Wood sizes shown on plan are nominal and refer to stock dimensional products.
- E. Concrete Pier Block with metal bracket shall comply with ASTM C 90.
- F. Gate to have Grainger tee hinge: steel black enamel model 1WBJ7 or approved equal.
- G. Gate to have Abus Rotating Eye Hasp: 6 in Hasp Length, 2 3/8 in Hasp Width, 5 7/8 in Hasp Height, 9/16 in Maximum Shackle Diameter. Hasp shall be powder coated black.
- H. Padlock for gate locking to be furnished and installed by Owner.
- I. Ladder to be Acudor 6' ladder – wall mounted galvanized aluminum product LAD-06-AL or approved equal.
- J. Ladder rung covers to be Vigil Antislip tubular ladder rung covers, color to be slate/black. Or approved equal.
- K. Easy Grip Assist Handle - Aluminum – 24" or approved equal.

2.8 BOARDWALK THRESHOLD POLE

- A. Two (2) threshold poles, per drawings, shall be Owner Furnished and Contractor Installed. Threshold poles shall comply with Section 061316 – Pole Construction. Install per detail in drawings.
- B. Mastic waterproofing shall be Gorilla Waterproof Patch & Seal, Rubber Sealant, Black, or approved equal.

2.9 JOIST TAPE

- A. 4" Imus Seal Butyl Joist Tape shall be installed on top of all wooden Joists and Beams.

2.10 ADHESIVE AND SEALANT

- A. Adhesive for bolts and nuts shall be Loctite Threadlocker Red 271.

**NISQUALLY STATE PARK
NEW FULL SERVICE PARK – PHASE 2**

2.11 FASTENERS, METAL HARDWARE, AND ACCESSORIES

- A. Fasteners and Metal Hardware in Preservative Treated Wood: For treated wood and where wood is in ground contact, subject to high relative humidity, or exposed to weather, provide corrosion resistant steel fasteners with hot-dip zinc coating per ASTM A153/A153M, provide corrosion resistant hardware per ASTM A653 / A653M Class G-185 in compliance with building code requirements.
- B. All bolts shall be of the diameter noted on plans. All bolts shall have nuts and washers of similar grade as noted.
- C. Anchor Bolts connecting the ledger to the Boardwalk abutment shall be hex bolts sized as specified on Plans.
- D. Type 316 Stainless Steel hold-down clips, or approved equal, for fastening decking as specified in Section 067413 Ecograte.
- E. Screws for toe nailing blocking shall be 6” to 8” length with electro zinc finish.
- F. Screws for toe nailing joists to beam shall be 6” length with electro zinc finish.
- G. Screws for toe nailing joists to joists shall be 6” length with electro zinc finish.
- H. Joist hangers for attaching joists to header at the abutment shall be Simpson HU410Z Hanger, or approved equal. Install with nails or screws of size as recommended by manufacturer.
- I. Angle Brackets for attaching edge joists to beams shall be Simpson HL49 Angle, or approved equal. Install with bolts of size as recommended by manufacturer.
- J. Angle Brackets at the Boardwalk, ramp, and overlook railing for attaching top and bottom rail to the guardrail post shall be Simpson Strong Tie HL35 with Galvanized finish.
- K. The Railing Tube Mount, shall be 1-3/4”x1-3/4”x2” tube steel fillet welded to 2”x5”x1/4” steel plate. The entire Railing Tube mount shall be hot dipped galvanized and conform to Section 055000 – Metal Fabrications.
- L. 2-1/8” square Tube Steel for attaching the handrail to the guardrail post at the Overlooks shall be hot dipped galvanized and conform to Section 055000 – Metal Fabrications.
- M. Fasten Railing Tube Mount to Guardrail Posts with machine bolts sized as specified on Plans.
- N. Fasten the Overlook Handrail to the 2-1/8” Tube Steel with 1/4” carriage bolt.
- O. Fasten tube steel to Railing Tube Mount with 1/4” machine bolt.
- P. Central Joists shall be hung from beam with Simpson HU410Z Joist Hanger or approved equal. Install with nails or screws of size as recommended by manufacturer of Type 304 Stainless Steel.
- Q. Beams shall be connected to posts with Simpson AC4Z Post Cap or approved equal. Install with nails or screws of size as recommended by manufacturer of Type 304 Stainless Steel.

**NISQUALLY STATE PARK
NEW FULL SERVICE PARK – PHASE 2**

- R. Post shall be connected to Diamond Pier Foundation with Simpson ABU 44z 4x4 adjustable post base Zmax finish or approved equal.
- S. Vigil Antislip tubular Ladder Rung Covers are to be installed with Sikaflex-219 or approved equal.

2.12 EXTRA PRODUCTS

- A. Contractor shall furnish and deliver five (5) 4'x10' Ecograte 62 Panels, fifty (50) E1 Clips to the Park Maintenance Facility. Coordinate delivery and storage location with Park Manager.

PART 3 - EXECUTION

3.1 GENERAL

- A. Stake alignment and location for Owner approval prior to installation.
- B. Install work rigid, plumb, and true to lines and levels shown. Verify that all elements called for in this Section “fit” according to the drawings.

3.2 PREPARATION

- A. Do not begin installation until substrates have been properly constructed and prepared.
- B. Prior to installing Diamond Pier Foundations, Contractor’s Surveyor shall survey elevations along edges of proposed Boardwalk, from which Contractor shall determine appropriate Boardwalk grades and slope.

3.3 HOLES FOR BOLTS AND SCREWS

- A. Holes drilled in wood for connecting hardware shall be drilled with a bit 1/16-inch smaller in diameter than the rod or bolt.
- B. Holes drilled in metal for connecting hardware shall be drilled to the size as specified per manufacturer recommendation.

3.4 FASTENING

- A. Washers of the size and type specified shall be used under all bolt nuts which would otherwise come in contact with wood. Check all bolts by burring the threads after the nuts have finally tightened. Vertical bolts shall have nuts on the lower end. In all cases where bolts are used to fasten timber to steel, bolt members tightly together when they are installed and retighten immediately prior to final acceptance of the work. All bolts shall have sufficient additional threading to provide at least 3/8-inch per foot thickness of timber for future retightening.

**NISQUALLY STATE PARK
NEW FULL SERVICE PARK – PHASE 2**

3.5 ADHESIVE AND SEALANT

- A. Apply Loctite Threadlocker Red 271 per manufacturer recommendation.
- B. Ensure nuts and bolts are clean and free from oil or dirt.
- C. Apply a few drops of Loctite Threadlocker on the bolt where the nut engagement area will be.
- D. Twist on the nut to the desired point and allow the full 24 hour cure time to be achieved.

3.6 INSTALLATION

- A. Install Diamond Pier Foundations as per Section 137000 Diamond Pier Foundations.
- B. Install 3x10 ledger at Boardwalk abutment per Plans so that decking surface is flush with top of abutment.
- C. Grades and slopes along the Boardwalk alignment are to be determined in the field by the Contractor as described on Plans.
- D. Slope of decking surface shall be maintained as per Plans.
- E. The Overlook viewing decks shall not slope more than 1% in any direction.
- F. Install beams true and plumb on post brackets with not more than 1/2" vertical difference from one end to the other. Verify mid-point of beam is centered over Boardwalk centerline.
- G. Make clean and accurate cuts for joints in beams and joists at viewing deck. Assure full contact of wood surfaces at joints with no more than 1/16 inch gaps in any part of joint after tightening bolts.
- H. Select the most defect free and aesthetically pleasing joists and install in the most visible locations. Install joists with specified hardware in proper spacing and alignment with planned Boardwalk centerline. Outer joists shall have hardware mounted only on the back side (out of view). Install joists plumb with 1/4" gap between ends at beams. Install blocking as required to stabilize.
- I. Install bolts with nut & thread ends on least visible side of connection.
- J. Install 4" Imus Seal Butyl Joist Tape on top of all wooden Joists and Beams.
- K. Install Railing and Decking as shown in Plans.
- L. Heavy duty handrail mounting bracket McMaster-CARR 5144N15 shall be fastened to the wood Boardwalk, ramps, and overlooks with carriage bolt of size as recommended by manufacturer.
- M. Weld the 2" O.D. galvanized steel pipe handrail to the heavy-duty handrail mounting bracket McMaster-CARR 5144N15, provide a continuous weld to permanently connecting rail and mounting components. Comply with requirements for welded connections in "Fabrication" Article whether welding is performed in the shop or in the field.

**NISQUALLY STATE PARK
NEW FULL SERVICE PARK – PHASE 2**

- N. Ensure the horizontal ends of the welded wire mesh panels are concealed within 4x6 guardrail posts. There shall be no horizontal tags that protrude from cut welded wire mesh panel. Contractor shall ensure welded wire mesh panel shall have seamless transitions from end to end.
- O. Install gate in location as shown in plans. Gate to open inward towards Boardwalk smoothly.
- P. Grainger Tee Hinges of gates to be installed with 1/4” Carriage Bolts.
- Q. Rotating Eye Hasps to be installed on gate so that the bottom and top of gate can be locked.
- R. Install Ladder as shown in Plans. Ensure that concrete pier blocks are fully buried.
- S. Ensure ladder rungs are clean and free of loose paint and corrosion. Install Vigil Antislip Tubular Ladder Rung Covers on ladder with a generous bead of Sikaflex-219 adhesive along each internal corner of each ladder rung cover so that they are about one quarter filled. Starting with the top ladder rung, place Ladder Rung Cover over it and while swiveling it back and forth, apply downward pressure until adhesive oozes out each end. Ensure that top surface is horizontal and clean the adhesive from each end. Do not use ladder for a minimum of 6 hours post installation.
- T. Install Easy Grip Assist Handle to railings on both sides of ladder with 3/8” carriage bolt through the handle, railing, and joist.
- U. Install Threshold Poles per detail in drawings. Poles shall be installed level and plumb. The decorative side of the poles shall face outwards towards the trail. Confirm placement with Owner’s Representative before install.
- V. Take precautions to prevent any marring and gouging of wood members and decking surfaces during construction. Repair all damaged surfaces after completing construction.

3.7 THRESHOLD POLES

- A. Contractor shall apply mastic waterproofing per manufacturer recommendation. The threshold poles shall be cleaned, dry, and free from debris before application of mastic waterproofing. Apply two coats of the mastic waterproofing as indicated in the Plan. Ensure the mastic waterproofing is cured and dry per manufacturer recommendation before installing into the ground.

3.8 FINISH

- A. Contractor shall sand smooth all Top Rail surfaces along the Boardwalk and Boardwalk Ramp to remove all burrs, loose wood, and smooth out indentations.
- B. The edges on the Guardrail Posts at the Boardwalk Handrail and Boardwalk Ramp Handrail, shall be sanded round to 1/2” radius. All exposed wood surface of the Guardrail Posts shall be sanded to remove all burrs, loose wood, roughness, and smooth out indentations. Sand smooth so the surface still complies with manufacturer’s standard for exterior use, but also so that it is smooth enough that when a human hand slides across the Guardrail Post surface it is smooth to the touch and no splinters are incurred.

**NISQUALLY STATE PARK
NEW FULL SERVICE PARK – PHASE 2**

- C. The edges on the Handrail at the Overlooks shall be sanded round to 1/2” radius. All exposed wood surface of the Handrail shall be sanded to remove all burs, loose wood, roughness, and smooth out indentations. Sand smooth so the surface still complies with manufacturer’s standard for exterior use, but also so that it is smooth enough that when a human hand slides across the Handrail surface it is smooth to the touch and no splinters are incurred.

3.9 CLEANING

- A. Clean up debris and unused or excess material and remove from the site.
- B. Paint all scratches, marks, and minor gouges less than 1/16 in. deep/wide to match the color of the surrounding material. Any scratches, marks, and minor gouges greater than 1/16 in. deep/wide requires the replacement of the damaged furnishing. Touch-up, repair or replace damaged products before Substantial Completion.

END OF SECTION

**NISQUALLY STATE PARK
NEW FULL SERVICE PARK – PHASE 2**

SECTION 136000 - KIOSKS

PART 1 - GENERAL

1.1 SCOPE OF WORK

- A. Provide material, equipment, labor, and related items necessary to complete the work shown on the Drawings and/or as specified in the Specifications. The items of work to be performed shall include but are not limited to:
 - 1. Construction of the 6-Sided and 2-Sided Kiosks.

1.2 REFERENCES

- A. American Society of Testing and Materials (ASTM).
- B. American Institute of Timber Construction (AITC).
- C. West Coast Lumber Inspection Bureau (WCLIB).
- D. American Wood Protection Association (AWPA).
- E. Western Red Cedar Lumber Association (WRCLA)

1.3 RELATED WORK

- A. Coordinate related work specified in other parts of the Project Specifications, including, but not limited to the following:
 - 1. Section 033000 – Cast-in-Place Concrete
 - 2. Section 051200 – Structural Steel Framing
 - 3. Section 055000 – Metal Fabrications
 - 4. Section 060573 – Wood Treatment
 - 5. Section 061000 – Rough Carpentry
 - 6. Section 061316 – Pole Construction
 - 7. Section 073013 – Roof Underlayments
 - 8. Section 074113.16 – Standing-Seam Metal Roof Panels
 - 9. Section 079200 – Joint Sealants

**NISQUALLY STATE PARK
NEW FULL SERVICE PARK – PHASE 2**

1.4 SUBMITTALS

- A. Submit supplier certificate stating compliance with the requirements and specifications of this Section and compliance with minimum allowable unit stresses.
- B. Product Data:
 - 1. Manufacturer's data sheets on each product to be used.
 - 2. Preparation instructions and recommendations.
 - 3. Storage and handling requirements and recommendations.
- C. Shop Drawings: Contractor shall include details of materials, construction, and finish. Include cross sections of the 6-sided and 2-sided kiosks prior to construction. Include relationship with adjacent construction.

1.5 QUALITY ASSURANCE

- A. Manufacturer Qualifications: Company specializing in manufacturing products specified in this section with a minimum of five years documented experience.
- B. Installer Qualifications: Company specializing in performing Work of this section with minimum five years documented experience with projects of similar scope and complexity.
- C. Source Limitations: Provide each type of product from a single manufacturing source to ensure uniformity.

1.6 DELIVERY, STORAGE AND HANDLING

- A. Where required, all materials shall be protected from the weather by suitable covering. Coordinate scheduled delivery of all wood materials to avoid extended on-site storage and to avoid delaying the work. Handle lumber carefully without sudden dropping, breaking of the outer fibers, bruising, or penetrating the surface with tools. Handle lumber with rope slings; no cant dogs, peaveys, hooks, or pike poles shall be used. Hardware received at the site shall be protected from corrosion by storing under cover. Storing and handling shall conform to AWPAM4.

PART 2 - PRODUCTS

2.1 WOOD TREATMENT

- A. Dimensional lumber as specified in the following section, used in construction of the Kiosks, shall be treated per Section 060573 – Wood Treatment.
- B. Wood Poles shall be treated per Section 061316 – Pole Construction.

**NISQUALLY STATE PARK
NEW FULL SERVICE PARK – PHASE 2**

2.2 BEAMS, RAFTERS, RAILS, FASCIA, AND TRIM

- A. Beams and Rafters shall be No. 2 Structural or better Hem/Fir, S4S.
- B. Rails shall be No. 1 Structural or better Hem/Fir, S4S.
- C. Fascia and Trim shall be Clear, A-Grade Cedar.
- D. Beams, rafters, rails, fascia, and trim are nominal and refer to stock dimensional products, size as indicated on Plans.
- E. Beams, Rafters, and Rails shall be treated with Preserve CA-C (Copper Azole) for above ground use category UC3B.

2.3 SHEATHING AND PLYWOOD

- A. Kiosks' Roof Sheathing shall be ¾" Marine Grade Douglas Fir plywood with Grade A front (sanded) facing down and Grade B back facing up. Plywood shall be made with moisture-resistant adhesives that meet ASTM 2559. No surface treatments with added urea-formaldehyde resins or coatings and shall be APA Trademarked and Compliant with PS 1-19.
- B. Kiosks' Display Backing Plywood shall be ¾" Marine Grade Douglas Fir plywood with Grade A front (sanded) and Grade A (sanded) back. Plywood shall be made with moisture-resistant adhesives that meet ASTM 2559. No surface treatments with added urea-formaldehyde resins or coatings and shall be APA Trademarked and Compliant with PS 1-19.
- C. Sheathing and plywood shall be treated with Preserve CA-C (Copper Azole) for above ground use category UC3B.

2.4 WOOD POLES

- A. Wood poles shall comply with Section 061316 – Pole Construction.

2.5 FOOTINGS

- A. Foundations' concrete shall be Class 4000.

2.6 ROOFING

- A. Roofing shall comply with Section 074113.16 – Standing Seam Metal Roof Panels.

2.7 STEEL POSTS, FRAMING, AND FABRICATIONS

- A. Steel Tubing for posts and Steel Framing shall be ASTM A 501. All Metal Fabrications shall comply with Section 055000 Metal Fabrications-Sitework. Steel Posts, Framing, and Fabrications shall be hot dipped galvanized and painted Black.

**NISQUALLY STATE PARK
NEW FULL SERVICE PARK – PHASE 2**

2.8 STEEL STRAP

- A. Steel Straps shall be 3” wide by 3/16” thick by 10 1/8” diameter galvanized steel, painted black, with 4 holes drilled on center of strap and equally spaced, and shall comply with Section 055000 – Metal Fabrications.

2.9 TUBE STEEL

- A. Tube steel for the kiosk framework shall comply Section 051200 – Structural Steel Framing. The finish for the tube steel shall be black.

2.10 KERF PLATE

- A. Kerf steel plate for the 2-sided kiosk footing shall comply with Section 055000 – Metal Fabrications.

2.11 ADHESIVE AND SEALANT

- A. Adhesive for bolts and nuts shall be Loctite Threadlocker Red 271.

2.12 FASTENERS

- A. Fasteners and Metal Hardware in Preservative Treated Wood: For treated wood and where wood is in ground contact, subject to high relative humidity, or exposed to weather, provide corrosion resistant steel fasteners with hot-dip zinc coating per ASTM A153/A153M, provide corrosion resistant hardware per ASTM A653 / A653M Class G-185 in compliance with building code requirements.
- B. All bolts connecting hardware to timbers shall be galvanized steel hex bolts with black finish of the size noted on Drawings. All bolts shall have nuts and washers of similar grade/size as noted.
- C. Wood Screws to secure Facia to Rafters shall be #10 x 3” Round Washer Head with Square/Phillips Combo Recess Type-17 with Electro Zinc finish.
- D. Security Screws to secure 2 x 2 Trim to the 4 x 6 Rails and to the wood pole, shall be #10 x 2 1/2” Round Washer Head with Phillip-Pin Security Head Type-17 with Electro Zinc finish.
- E. Security Screws to secure 3” Steel Strap to the 10” diameter wood pole, shall be #10 x 1 1/2” Round Washer Head with Phillip-Pin Security Head Type-17 with Electro Zinc finish.
- F. Wood Screws to secure Rafters to Beams shall be #10 x 2 1/2” long Tapered Phillips Head with Electro Zinc finish.
- G. Wood Screw to secure Rafters to Steel Frame work shall be #10 x 4” long Tapered Phillips Head with Electro Zinc finish.
- H. Lag Bolt to secure L Bracket to Rails shall be 1/2” dia, 2-1/2” galvanized hex head finish.

**NISQUALLY STATE PARK
NEW FULL SERVICE PARK – PHASE 2**

- I. Machine Bolts to secure Kerf Plate to round wood poles shall be galvanized hex head with a galvanized finish and size as indicated in plans.

PART 3 - EXECUTION

3.1 GENERAL

- A. Stake alignment and location for Owner approval prior to installation.
- B. Install work rigid, plumb, and true to lines and levels shown. Verify that all elements called for in this Section “fit” according to the drawings.

3.2 PREPARATION

- A. Do not begin installation until substrates have been properly constructed and prepared.
- B. Prior to installing Footings, Contractor’s Surveyor shall survey in the horizontal locations and vertical elevation the center point of each of the footings.
- C. Contractor shall compact excavation backfills to 95% MDD.
- D. Concrete pavements and ground surfaces shall not be installed until Kiosks are substantially complete as determined by the Owner.

3.3 HOLES FOR BOLTS AND SCREWS

- A. Holes drilled in wood for connecting hardware and fasteners shall be drilled with a bit 1/16-inch smaller in diameter than the screws and bolts.
- B. Holes drilled in metal for connecting hardware shall be drilled to the size as specified per manufacturer recommendation.

3.4 FASTENING

- A. Washers of the size and type specified shall be used under all bolt nuts which would otherwise come in contact with wood. Check all bolts by burring the threads after the nuts have finally tightened. Vertical bolts shall have nuts on the lower end. In all cases where bolts are used to fasten timber to steel, bolt members tightly together when they are installed and retighten immediately prior to final acceptance of the work. All bolts shall have sufficient additional threading to provide at least 3/8-inch per foot thickness of timber for future retightening.
- B. Secure Facia to the Rafters with 2 wood screws centered on the Rafter. Screw Heads shall be on the Facia side and equally spaced. All Facia wood screws shall be in the same location/pattern for all Rafters.
- C. Secure 2 x 2 Trim to the 4 x 6 Rails with 5 security screws. The outer wood screws shall be installed 4 inches from each miter joint with the remaining wood screws equally spaced. Secure

**NISQUALLY STATE PARK
NEW FULL SERVICE PARK – PHASE 2**

2 x 2 Trim to the 10” wood pole with 3 wood screws. The outer wood screws shall be installed 4 inches from each miter joint with the remaining wood screw centered on the vertical trim.

- D. Secure Rafters to Beams with 3 wood screws toe-nailed equally spaced along the joint. Two of the toe-nailed wood screws shall be on one side and the other wood screw shall be installed on center of the joint on the opposite side.
- E. Secure 2 x 8 Rafters to Steel Framework (triangular shape) with one 4” Wood Screw on center of Steel Framework.

3.5 ADHESIVE AND SEALANT

- A. Apply Loctite Threadlocker Red 271 per manufacturer recommendation.
- B. Ensure nuts and bolts are clean and free from oil or dirt.
- C. Apply a few drops of Loctite Threadlocker on the bolt where the nut engagement area will be.
- D. Twist on the nut to the desired point and all the full 24 hour cure time to be achieved.

3.6 INSTALLATION

- A. Take precautions to prevent any marring and gouging of wood members, tube steel, and steel hardware during construction. Repair all damaged surfaces after completing construction.
- B. Tube Steel and Steel Straps shall be installed per Section 051200 – Structural Steel Framing and 055000 – Metal Fabrications.
- C. Wood poles to be installed per Section 061316 – Pole Construction

3.7 FINISH

- A. Contractor shall sand smooth all exposed wood surfaces to remove all burrs, loose wood, and smooth out indentations.

3.8 CLEANING

- A. Clean up debris and unused or excess material and remove from the site.
- B. Sand out all scratches, marks, and minor gouges less than 1/16 in. deep/wide. Any scratches, marks, and minor gouges greater than 1/16 in. deep/wide requires the replacement of the damaged furnishing. Touch-up, repair or replace damaged products before Substantial Completion.

END OF SECTION

**NISQUALLY STATE PARK
NEW FULL SERVICE PARK – PHASE 2**

SECTION 137000 – DIAMOND PIER FOUNDATION

PART 1 - GENERAL

1.1 SCOPE/DESCRIPTION

- A. The general conditions, alternates and addenda, applicable drawings, and technical specifications shall apply to all work under this section.
- B. The contractor shall furnish all materials, labor, equipment, and incidentals as shown, specified, and required to install Diamond Pier foundations for the Ohop Boardwalk and Overlooks.
- C. Work includes preparing site and soil; furnishing and preparing foundation components; aligning, leveling, plumbing, and installing foundation components; setting and driving foundation pins; and capping pins.

1.2 RELATED WORK

- A. Section 133700 Boardwalk
- B. Section 311100 Clearing and Grubbing
- C. Section 312000 Earth Moving

1.3 REFERENCES/STANDARDS

- A. ASTM A 53 – Standard Specification for Pipe
- B. ASTM A153 – Standard Specification for Zinc Coating on Hardware
- C. ASTM, ACI, and CRSI standards for precast concrete products
- D. ASTM C1116/C1116M-10a – Standard Specification for Synthetic Fiber Reinforcing – Type III, when applicable

1.4 SUBMITTALS

- A. Latest edition of Commercial Installation Instructions for public or commercial projects.
- B. Manufacturers or Engineer's evaluation of foundation system load capacities for this project.
 - 1. Quality Assurance/Testing
 - 2. Stamped certified soil testing and outside inspection or vendor supervision will be paid for by the owner.

**NISQUALLY STATE PARK
NEW FULL SERVICE PARK – PHASE 2**

- C. Product Data:
1. Manufacturer's data sheets on each product to be used.
 2. Preparation instructions and recommendations.
 3. Storage and handling requirements and recommendations.

1.5 DELIVERY/STORAGE AND HANDLING

- A. Contractor shall verify upon delivery that all the proper materials have been received.
- B. Contractor shall protect the materials from damage. See “Temporary Product Storage” in the Commercial Installation Instructions.
- C. Contractor shall review MSDS documents and, when required, maintain a copy on site at all times.

1.6 QUALITY ASSURANCE

- A. Manufacturer Qualifications: Company specializing in manufacturing products specified in this section with a minimum of five years documented experience.
- B. Installer Qualifications: Company specializing in performing Work of this section with minimum five years documented experience with projects of similar scope and complexity.
- C. Source Limitations: Provide each type of product from a single manufacturing source to ensure uniformity.
- D. Mock-Up: Construct a mock-up with actual materials in sufficient time for Landscape Architect's review and to not delay construction progress. Locate mock-up as acceptable to Landscape Architect and provide temporary foundations and support.
 1. Intent of mock-up is to demonstrate quality of workmanship and visual appearance.
 2. If mock-up is not acceptable, rebuild mock-up until satisfactory results are achieved.
 3. Retain mock-up during construction as a standard for comparison with completed work.
 4. Do not alter or remove mock-up until work is completed or removal is authorized.
 5. Mock-up may become part of the finished work as approved by the Landscape Architect.

PART 2 - BASIS OF DESIGN

2.1 MANUFACTURER

- A. Pin Foundations, Inc. Facility Address: 2105 34th Ave. NW, Gig Harbor, WA 98335, phone 253-858-8809. Mailing Address: 4810 Pt. Fosdick Dr. NW, PMB 60, Gig Harbor, WA 98335.

2.2 SYSTEM TYPE

- A. Diamond Pier foundation – DP-75 – Precast heads to be minimum 5500 psi concrete, minimum 3/8” aggregate, with 5- 7% total air entrainment, and no reinforcing fibers.

**NISQUALLY STATE PARK
NEW FULL SERVICE PARK – PHASE 2**

2.3 PINS/CAPACITY

- A. Four pins per pier. Capacity relative to length, diameter, and driving angle in site-specific soils. Stamped capacities shall rely on stamped local geotechnical evaluations and complete project loading and site information. All pins to be minimum Schedule 40 galvanized steel pipe (UNO) with butt cut driving ends (UNO).
- B. DP-75 to use 1-1/4" nominal pipe - 1.67" actual OD. DP-100E to use 1-1/2" nominal pipe – 1.9" actual OD. DP-200E to use 2" nominal pipe – 2.375" actual OD. Pins to be capped with UV resistant vinyl caps. Sealable caps to be sealed with 50-year adhesive caulk (UNO).

2.4 CONNECTIONS/POSTS/BEAMS

- A. Diamond Pier connection to be galvanized steel post base attached to pier with single galvanized anchor bolt (UNO). Anchor bolt for DP-75 to be 5/8" galvanized, ASTM A 307 Grade A. Four-bolt configuration (4B) bolt diameters to be 1/2", for the DP-75 4B, respectively.
- B. Pressure-treated posts to have factory treated ends at bracket interface when feasible.

PART 3 - EXECUTION

3.1 INSPECTION

- A. Contractor shall verify superstructure layout, spans, and resulting loads for consistency with the manufacturers or engineer's evaluated capacities and report any inconsistencies to the owner's agent prior to installation.

3.2 SITE PREP

- A. Use of heavy equipment and/or alteration of site soils or vegetation to be kept to a minimum to avoid compaction, erosion, and the need for site repair or replanting.

3.3 EQUIPMENT/INSTALLATION

- A. Install per manufacturer Diamond Pier Foundation Installation Manual, included in the appendix at the end of the project manual.
- B. Pins to be full length as specified before driving. No coupled or welded pins are to be used.
- C. Follow Commercial Installation Instructions for pier placement and pin driving
- D. Pins may be cut off in a partially driven position if they meet substantial resistance in the soil as verified by Owner.

END OF SECTION

**NISQUALLY STATE PARK
NEW FULL SERVICE PARK – PHASE 2**

SECTION 138000 – HORSE MOUNTING BLOCK

PART 1 - GENERAL

1.1 SCOPE OF WORK

- A. Provide material, equipment, labor, and related items necessary to complete the work shown on the Drawings and/or as specified in the Specifications. The items of work to be performed shall include but are not limited to:
 - 1. Construction of the horse mounting block.

1.2 REFERENCES

- A. American Society of Testing and Materials (ASTM).
- B. American Institute of Timber Construction (AITC).
- C. West Coast Lumber Inspection Bureau (WCLIB).
- D. American Wood Protection Association (AWPA).
- E. AWS D1.4 - Structural Welding Code for Reinforcing Steel.
- F. CRSI - Concrete Reinforcing Steel Institute - Manual of Practice.
- G. CRSI 63 - Recommended Practice for Placing Reinforcing Bars.
- H. CRSI 65 - Recommended Practice for Placing Bar Supports, Specifications and Nomenclature.

1.3 RELATED WORK

- A. Coordinate related work specified in other parts of the Project Specifications, including, but not limited to the following:
 - 1. Section 060573 – Wood Treatment
 - 2. Section 061000 – Rough Carpentry
 - 3. Section 321500 – Crushed Rock Surfacing

1.4 SUBMITTALS

- A. Submit supplier certificate stating compliance with the requirements and specifications of this Section and compliance with minimum allowable unit stresses.
- B. Shop Drawings: Contractor shall submit cross sections of the horse mounting block prior to construction.

**NISQUALLY STATE PARK
NEW FULL SERVICE PARK – PHASE 2**

1.5 QUALITY ASSURANCE

- A. Installer Qualifications: Company specializing in performing work of this section with a minimum of five years documented experience with projects of similar scope and complexity.
- B. Source Limitations: Provide each type of product from a single manufacturing source to ensure uniformity.
- C. Tolerances: Current published edition of ASTM specifications tolerances apply. ASTM specification tolerances supersede any conflicting tolerance.

1.6 PRODUCT DELIVERY, STORAGE AND HANDLING

- A. Where required, all materials shall be protected from the weather by suitable covering. Coordinate scheduled delivery of all wood materials to avoid extended on-site storage and to avoid delaying the work. Handle lumber carefully without sudden dropping, breaking of the outer fibers, bruising, or penetrating the surface with tools. Handle lumber with rope slings; no cant dogs, peaveys, hooks or pike poles shall be used. Hardware received at the site shall be protected from corrosion by storing under cover. Storing and handling shall conform to AWWA M4.

PART 2 - PRODUCTS

2.1 WOOD TREATMENT

- A. Dimensional lumber as specified in the following section, used in construction of the Kiosks, shall be treated per Section 060573 – Wood Treatment.

2.2 HORSE MOUNTING BLOCK

- A. Tread face lumber shall be No 3 & Better pressure treated Hem-Fir, S4S
- B. Tread side lumber shall be No 2 & Better pressure treated Hem-Fir, S4S
- C. Tread face lumber shall be 6x6.
- D. Tread side lumber shall be 4x6.
- E. All lumber used for constructing the horse mounting block shall be treated with Preserve CA-C (Copper Azole) rated for ground contact, use category UC4A, per Section 060573 – Wood Treatment.
- F. Backfill for stair treads shall be Crushed Rock Surfacing A and shall comply with Section 321500 Crushed Rock Surfacing.

**NISQUALLY STATE PARK
NEW FULL SERVICE PARK – PHASE 2**

2.3 FASTENERS

- A. Fasteners and Metal Hardware in Preservative Treated Wood: For treated wood and where wood is in ground contact, subject to high relative humidity, or exposed to weather, provide corrosion resistant steel fasteners with hot-dip zinc coating per ASTM A153/A153M, provide corrosion resistant hardware per ASTM A653 / A653M Class G-185 in compliance with building code requirements.
- B. Wood screws to secure 2x6 sides to the stair tread face shall be #10 x 6” Round Washer Head with Square/Phillips Combo Recess Type-17 with Electro Zinc & Black finish.
- C. #4 Rebar shall secure the 6x6 stair tread face to the ground. The rebar shall recess 1/2-inch below top of tread, and shall extend 18-inches below the finish grade into the ground.

PART 3 - EXECUTION

3.1 PREPARATION

- A. Do not begin installation until substrates have been properly constructed and prepared.
- B. Prior to installing horse mounting block, Contractor’s Surveyor shall survey in the horizontal locations and vertical elevation of the center point of each of the mounting block treads.
- C. Contractor shall compact all backfills to 95% MDD.

3.2 HOLES FOR REBAR AND SCREWS

- A. Holes for connecting hardware and fasteners shall be drilled with a bit 1/16-inch smaller in diameter than the rebar and screws.

3.3 FASTENING

- A. Secure a 4x6 to the 6x6 treads with 2 wood screws centered on each abutment of the 6x6 tread. Screw heads shall be on the 4x6 side and equally spaced. All wood screws shall be in the same location and pattern for all treads. Wood screws shall avoid intersecting with rebar.
- B. Predrill a hole into the treads for the rebar. Secure each 6x6 tread with 2 rebars, centered on each tread and equally spaced, per drawing. Rebar shall recess 1/2-inch from the surface of the tread, and shall extend 18-inches below the finish grade.

3.4 INSTALLATION

- A. Install Crushed Rock Surfacing A per section 321500 Crushed Rock Surfacing.
- B. Take precautions to prevent any marring and gouging of wood members and decking surfaces during construction. Repair all damaged surfaces after completing construction.

**NISQUALLY STATE PARK
NEW FULL SERVICE PARK – PHASE 2**

3.5 FINISH

- A. Contractor shall sand smooth all exposed wood surfaces to remove all burrs, loose wood, and smooth out indentations.

3.6 CLEANING

- A. Clean up debris and unused or excess material and remove from the site. Completely remove all concrete, mud, dirt and other substances from horse mounting block.
- B. Touch-up, repair or replace damaged products before Substantial Completion.

END OF SECTION

**NISQUALLY STATE PARK
NEW FULL SERVICE PARK – PHASE 2**

SECTION 210500 – GENERAL FIRE SUPPRESSION REQUIREMENTS

PART 1 - GENERAL

1.1 WORK INCLUDED

- A. General Fire Suppression Requirements.
- B. Fire Suppression Submittals.
- C. Motors.
- D. Equipment and Fire Suppression System Identification.
- E. Commissioning.

1.2 GENERAL

- A. Includes, but not limited to, furnishing labor, materials, and equipment for completion of work unless indicated or noted otherwise. See Division 1 for sequence of work.
- B. All work included in Division 21 shall be the responsibility of a single Fire Suppression Subcontractor. This Contractor shall obtain and pay for all permits required by State and local authorities governing the installation of the mechanical work. It is the Contractor's responsibility to contact all utility organizations serving the building, prior to bid, and to include all charges for inspections, installation of materials, equipment and connection of all required utilities.
- C. Furnish exact location of electrical connections and complete information on motor controls to Division 26
- D. The drawings and specifications are complementary and what is called for in either is binding as if called for in both.
- E. The ductwork and accessibility to HVAC equipment shall take precedence over all other equipment in the ceiling interstitial spaces or other mechanical areas. Fire sprinkler piping shall route around ducts and HVAC.
- F. All Fire Suppression equipment and devices provided under other Divisions of this specification which require connection to any mechanical systems (i.e., plumbing systems or duct systems, or controls) shall be connected under this Division of the Specifications.
- G. The Contractor shall be responsible for checking field conditions and verifying all measurements and relationships indicated on the drawings before proceeding with the work.

1.3 ELECTRICAL

**NISQUALLY STATE PARK
NEW FULL SERVICE PARK – PHASE 2**

- A. All electrical work, conduit, boxes and devices in connection with control wiring as required to install the control equipment as specified herein or shown on the drawings shall be furnished and installed complete by the Division 21 Contractor.
- B. All electrical work performed under this section of the Specifications shall conform to all applicable portions of the Division 26 specifications and shall conform to all governing codes.
- C. All equipment shall be factory wired to a junction box for connection to electrical service.
- D. Where a piece of equipment specified includes an electric motor, the motor shall be furnished and mounted by this Contractor. Motor starter, disconnect switches and wiring from the electrical panel to the motor control devices and to the motor shall be provided by the Division 26 Contractor unless stated otherwise in the mechanical specification and on the mechanical equipment schedule.

1.4 SYSTEMS DESCRIPTION

- A. Site Inspection:
 - 1. Examine premises and understand the conditions which may affect performance of work of this Division before submitting proposals for this work.
 - 2. No subsequent allowance for time or money will be considered for any consequence related to failure to examine site conditions.
- B. Drawings:
 - 1. Mechanical drawings show general arrangement of piping, ductwork, equipment, etc. Follow as closely as actual building construction and work of other trades will permit.
 - 2. Consider electrical drawings part of this work insofar as these drawings furnish information relating to design and construction of building.
 - 3. Because of small scale of mechanical drawings, it is not possible to indicate all offsets, fittings, and accessories which may be required. Investigate structural and finish conditions affecting this work and arrange work accordingly, providing such fittings, valves, and accessories required to meet conditions.

1.5 SUBMITTALS

- A. All material used on the project shall be new and free of defects. The Engineer reserves the right to reject any material, the appearance of which has been damaged on the site or in shipment. The material shall be of approved equal quality to that which is specified. Should the make and type of material differ from that specified, the Contractor may be required to submit catalog and engineering data (samples if requested) necessary to make a comparison and determine its suitability. The Contractor shall also bear the cost of any changes to the electrical design made necessary by any approved substitutions. Such request for approval shall be made two weeks in advance of the bid opening to allow time to assess its suitability. Failure to obtain approval prior to bid shall require the successful bidder to furnish materials and equipment only as specified herein.

**NISQUALLY STATE PARK
NEW FULL SERVICE PARK – PHASE 2**

- B. The Contractor shall submit to the Engineer, for approval, complete information on all equipment and materials to be provided on the project including six copies of the manufacturer's catalog and engineering data, shop drawings of shop fabricated equipment and instruction data for each item included under this section of the specifications. Submittals shall be presented to the Engineer within 30 calendar days from the date of the contract signing in complete indexed and bound sets. The Contractor shall submit a typed, signed list including all items to be furnished on the project. The signature on the aforementioned list shall indicate that the contractor has examined the suitability of all material and equipment with respect to compliance with these specifications. The Contractor's approval shall also indicate that physical dimensions of the equipment have been verified with the installation requirements and were found to cause no interference therewith.
- C. Review of submittal data by the Engineer or Engineer does not relieve the Contractor of responsibility for quantities, measurements, and compliance with the intent of all contract documents.
- D. Furnish submittals on the following equipment in a hard-back, three-ring binder:
 - 1. Pipe
 - 2. Valves
 - 3. Pipe Hangers
 - 4. Fire Sprinkler Specialties
 - 5. Fire Sprinklers
 - 6. Fire Suppression Equipment
- E. The Contractor shall submit the fire suppression cost breakdown including all sub-contractors costs.

1.6 OPERATION AND MAINTENANCE MANUAL FOR FIRE SUPPRESSION SYSTEMS

- A. Bind Operation & Maintenance Manual for Fire Suppression Systems in three-ring, hard-backed binder with clear plastic pocket on spine. Spine of each binder shall have following typewritten lettering inserted:

**OPERATION AND MAINTENANCE MANUAL
FOR FIRE SUPPRESSION SYSTEMS**

- B. Provide master index at beginning of Manual showing items included. Use plastic tab indexes for sections of Manual.
- C. First section shall consist of name, address, and phone number of Engineer, General Contractor, and Mechanical, Plumbing, Sheet Metal, Refrigeration, Temperature control, and Electrical subcontractors. Also include complete list of equipment installed with name, address, and phone number of each vendor.
- D. Provide section for each type of item of equipment.
- E. Submit copies of Operation & Maintenance Manual to Engineer for approval.
- F. Include descriptive literature (Manufacturer's catalog data) of each manufactured item. Literature shall show capacities and size of equipment used and be marked indicating each specific item with applicable data underlined.

**NISQUALLY STATE PARK
NEW FULL SERVICE PARK – PHASE 2**

- G. Operating Instructions shall include:
 - 1. General description of each fire suppression system.
 - 2. Step-by-step procedure to follow in putting each piece of fire suppression equipment into operation.

- H. Maintenance Instructions shall include:
 - 1. Manufacturer's maintenance instructions for each piece of fire suppression equipment installed in Project. Instructions shall include name of vendor, installation instructions, parts numbers and lists operation instructions of equipment, and maintenance and lubrication instruction.
 - 2. Summary list of equipment requiring lubrication showing name of equipment, location, and type and frequency of lubrication.
 - 3. List of fire suppression equipment used indicating name, model, serial number, and nameplate data of each item together with number and name associated with each system item.

1.7 **QUALITY ASSURANCE**

- A. Requirements of Regulatory Agencies:
 - 1. Perform work in accordance with applicable Codes.
 - 2. In case of differences between building codes, state laws, local ordinances, utility company regulations, and Contract Documents, the most stringent shall govern.

- B. Product Approvals: See paragraphs elsewhere in this specification.

- C. Manufacture: Use domestic made pipe, pipe fittings, valves, sprinklers and motors on project.

- D. Identification: Motor and equipment name plates as well as applicable UL and AGA labels shall be in place when Project is turned over to Owner.

1.8 **CODES AND STANDARDS**

- A. Codes and agencies having jurisdictional authority over Fire Suppression installation.
 - 1. International Building Code -- Latest Approved Edition
 - 2. International Mechanical Code -- Latest Approved Edition
 - 3. Uniform Plumbing Code -- Latest Approved Edition
 - 4. Local Sewer and Water District Requirements
 - 5. State and County Department of Health
 - 6. NFPA
 - 7. Uniform Fire Code
 - 8. Occupational Safety and Health Administration (OSHA)
 - 9. Washington Industrial Safety and Health Act (WISHA)

1.9 **PRODUCT HANDLING AND PROTECTION**

**NISQUALLY STATE PARK
NEW FULL SERVICE PARK – PHASE 2**

- A. Contractor is responsible for protection of all material, equipment and apparatus provided under this section from damage, water, corrosion, freezing and dust, both in storage and when installed, until final project acceptance.
- B. Provide temporary heated and sheltered storage facilities for material and equipment.
- C. Completely cover motors and other moving machinery to protect from dirt and water during construction.
- D. Handle and protect equipment and/or material in manner precluding unnecessary fire hazard.
- E. Equipment requiring rotation and/or lubrication during storage shall have records maintained and witnessed on a monthly basis and forwarded to the Engineer prior to acceptance.
- F. Material or equipment damaged because of improper storage or protection will be rejected.
- G. Equipment finish that is damaged by handling, storage, etc. shall be corrected by the Contractor at no additional cost to the Owner.

1.10 WARRANTIES

- A. In addition to guarantee specified in General Conditions, guarantee heating, cooling, and plumbing systems to be free from noise in operation that may develop from failure to construct system in accordance with Contract Documents.
- B. In order to be protected, secure proper guarantees from suppliers and subcontractors.
- C. Provide certificates of warranty for each piece of equipment. Clearly record "start-up" date of each piece of equipment on certificate. Include certificates as part of Operation & Maintenance Manual.

1.11 ABBREVIATIONS

1.	AFF	Above Finish Floor
2.	AMCA	Air Moving & Conditioning Association
3.	ANSI	American National Standards Institute
4.	APWA	American Public Works Association
5.	ARI	Air Conditioning and Refrigeration Institute
6.	ASHRAE	American Society of Heating, Refrigerating and Air Conditioning Engineers
7.	ASME	American Society of Mechanical Engineers
8.	ASTM	American Society of Testing & Materials
9.	AWWA	American Water Works Association
10.	BFF	Below Finish Floor
11.	BHP	Brake Horsepower
12.	BTU	British Thermal Unit
13.	CFC	Chloro - Fluorocarbon
14.	CFM	Cubic Feet per Minute
15.	DOT	US Department of Transportation

**NISQUALLY STATE PARK
NEW FULL SERVICE PARK – PHASE 2**

- | | | |
|-----|--|---|
| 16. | EPA | Environmental Protection Agency |
| 17. | fpm | feet per minute |
| 18. | FS or Fed. Spec. | Federal Specifications |
| 19. | HP | Horsepower |
| 20. | IEEE | Institute of Electrical and Electronics Engineers |
| 21. | KW | Kilowatt |
| 22. | MBH | One Thousand British Thermal Units per Hour |
| 23. | MS or Mil.Spec. | Military Specifications |
| 24. | MSS | Manufacturers Standardization Society |
| 25. | NEC | National Electrical Code |
| 26. | NEMA | National Electrical Manufacturers Association |
| 27. | per | in accordance with |
| 28. | PVC | Polyvinyl Chloride |
| 29. | SMACNA | Sheet Metal and Air Conditioning Contractors National Association |
| 30. | SP | Static Pressure |
| 31. | UL | Underwriter's Laboratories |
| 32. | w.g. | Water Gauge (inches of water) |
| 33. | WQA | Water Quality Association |
| 34. | Additional abbreviations are as listed on the drawings or elsewhere in these specifications. | |

1.12 DEFINITIONS

- A. Finished Spaces: Spaces used for habitation or occupancy where rough surfaces are plastered, panelled, or otherwise treated to provide a pleasing appearance.
- B. Unfinished Spaces: Spaces used for storage or work areas where appearance is not a factor.
- C. Concealed Spaces: Spaces out of sight. For example, above ceilings; below floors; between double walls; furred-in areas; pipe and duct shafts; and similar spaces.
- D. Exposed: Open to view. For example, pipe running through a room and not covered by other construction.
- E. Outside: Open to view up to 5 feet beyond the exterior side of walls, above the roof, and unexcavated or crawl spaces.
- F. Conditioned Space: An area, room or space normally occupied and being heated or cooled for human habitation by any equipment.

PART 2 - PRODUCTS

2.1 ACCEPTABLE MANUFACTURERS

- A. Any reference to the specifications or on the drawings to any article, device, product, material, fixture, form or type of construction by manufacturer, name, make, or catalog number shall be interpreted as establishing a standard of quality and shall not be construed as limiting competition.

**NISQUALLY STATE PARK
NEW FULL SERVICE PARK – PHASE 2**

- B. The manufacturer listed as Acceptable Manufacturers are approved for the items indicated without obtaining prior approval. Other manufacturers require prior approval.
- C. The listing of a manufacturer as an Acceptable Manufacturer does not necessarily mean that the products of that manufacturer are equal to those specified. The listing is only an indication of those manufacturers which may be capable of manufacturing, or have in the past manufactured, items equal to those specified, and is intended to aid the Contractor in identifying manufacturers.
- D. Products provided by Acceptable Manufacturers shall be equal to or superior to the specified manufacturer's item in function, appearance, and quality, and shall fulfill all requirements of the plans and specifications. The Engineer shall be the final judge as to whether an item meets these requirements or not. If a manufacturer is not certain that his product meets these requirements or not, then the manufacturer shall submit data as required to obtain the Design Consultant's approval.
- E. The approval of a manufacturer applies to the manufacturer only and does not relieve the Contractor from the responsibility of meeting all applicable requirements of the plans and specifications.
- F. Contractor shall be responsible for all costs to other trades and all revisions required to accommodate any products which are different than those specified or shown.
- G. In reviewing a manufacturer for acceptance, factors considered include the following: engineering data showing item's performance, proper local representation of manufacturer, likelihood of future manufacturer's local support of product, service availability, previous installation, previous use by Owner/Engineer and record, product quality, availability/quality of maintenance and operation data, capacity/performance compared to specified items, acoustics, items geometry/access utility needs, and similar concerns.
- H. If approval is received to use other than specified items, responsibility for specified capacities and insuring that items to be furnished will fit space available lies with this Division.
- I. If non-specified equipment is used and it will not fit job site conditions, this Division assumes responsibility for replacement with items named in Specification.

2.2 ACCESS DOORS

- A. This contractor shall be responsible for furnishing and installing flush mounted access doors in walls, ceiling and floors and chases where the following equipment is concealed and is not accessible through same.
 - 1. Valves (shut off)
 - 2. Alarm devices
- B. Doors shall be UL listed 16 ga. cold rolled steel with concealed hinge, screwdriver operated lock and prime coated. Furnish suitable for area mounted.
- C. Approved Manufacturers:
 - 1. Milcor

**NISQUALLY STATE PARK
NEW FULL SERVICE PARK – PHASE 2**

2. Karp
3. Greenheck

2.3 EQUIPMENT AND PIPING IDENTIFICATION

A. General: All piping, valves and fire suppression equipment shall be marked. All markings in concealed accessible spaces shall be reviewed and verified by Architect/Engineer prior to being concealed.

B. Piping: Piping shall be marked as follows:

1. Type: Self-sticking colored markers, lettered to identify the pipe contents, and banded at each end with arrow tape indicating the direction of flow. Markers shall be similar and equal to Brady "System 1" and Seton "Opti-Code" markers. Spray painted stencil labeling is not acceptable. Some markers may be special order.

2. Marker Colors and Wording:

Piping System & Wording	Background	Letters
Fire Sprinkler	White	Red

3. Marker Lettering: Lettering shall identify the material conveyed in each pipe. Systems which have supply and return piping shall have piping labeled as such (i.e. domestic hot water etc.). Size of letters and color field shall comply with ANSI A13.1., repeated here for convenience:

Outside Diameter of Pipe or Covering	Length of Color Field	Size of Letters
3/4 to 1-1/4 Inches	8 Inches	1/2 Inches
1-1/2 to 2 Inches	8 Inches	3/4 Inches
2-1/2 to 6 Inches	12 Inches	1-1/4 Inches

4. Locations: Markers shall be installed on all exposed piping adjacent to each shut-off valve, at branches to indicate changes of direction, where pipes pass through walls and floors, on 20 foot centers or at least one in each room on each pipe. Markers shall be installed on all concealed accessible piping (i.e., piping above suspended ceilings, behind access doors, in accessible chases, etc.) near the point of access, except that, for piping above suspended ceilings, markers shall be installed the same as if the piping was exposed (i.e., same as if the suspended ceiling was not in place). Markers shall be installed so as to easily read by a person standing on the floor. Provide additional direction of flow arrows at each pipe connections at all control valves.

C. Valves shall be marked as follows:

1. Identification tags made of brass or aluminum, stamped with valve number and abbreviation of system served (HTG, PLBG, CW, HW, GAS, AC). Tags shall be installed on all valves except stops at plumbing fixtures. Tags shall be not less than 1-1/2 inch in diameter, markings shall be stamped and black filled, and lettering shall be minimum 1/4-inch high with numbers minimum 1/2-inch high. Tags shall be wired to each valve with No. 6 polished nickel-steel jack chain.

D. All equipment which was scheduled on the Contract Drawings shall be marked with the name of the item; i.e., Heating Ventilating Unit No. 1, Exhaust Fan No. 2, Boiler No. 1 etc. The identification shall be the same as shown on the Contract Drawings. The marking shall be located

**NISQUALLY STATE PARK
NEW FULL SERVICE PARK – PHASE 2**

on two different sides of the equipment so as to be easily read, with at least one marking visible to a person standing at floor level near the unit (assuming any necessary access to a concealed unit has been made). Lettering shall be a minimum of 2" high. Marking shall be with engraved phenolic labels, white letters on black background. Equipment marking is not required for; air outlets and inlets, plumbing fixtures.

PART 3 - EXECUTION

3.1 WORKMANSHIP

- A. This Contractor shall provide completed systems with a neat and finished appearance. If, in the judgment of the Engineer, any portion of the work has not been performed in a workmanlike manner or is left in a rough, unfinished state, this Contractor will be required to remove, reinstall or replace same and patch and paint surrounding surfaces in a manner acceptable to the Engineer, without increase in cost to the Owner.

3.2 CLOSEOUT SUBMITTALS

- A. Requirements: Final approval of installation will be recommended upon completion of the following:
1. Completion of all punchlist items
 2. Permit Submittal
 3. Valve list posted
 4. Reproducible As-Built drawings delivered to Engineer
 5. Guarantees
 6. Signed off Permit

3.3 FINAL INSPECTION

- A. Final Inspection:
1. Prior to acceptance of the work, the Contractor shall put all fire suppression systems into operation for a period of not less than 5 working days so that they may be inspected by the Engineer and the Owner's representatives.
 2. The time of the final inspection shall be mutually agreed to by the Owner, Engineer, and Contractor.
 3. The Contractor shall furnish adequate staff to operate the fire suppression systems during inspection.

3.4 PREPARATION

- A. Existing Buildings
1. Cut carefully to minimize necessity for repairs to existing work. Do not cut beams, columns, or trusses.

**NISQUALLY STATE PARK
NEW FULL SERVICE PARK – PHASE 2**

2. Patch and repair walls, floors, ceilings, and roofs with materials of same quality and appearance as adjacent surfaces unless otherwise shown.
3. This work shall be scheduled such that utility services and/or existing systems for the facility are not interrupted during normal operating hours, without prior written permission of the Owner's representative. Work that is performed during normal operational hours shall not interfere with the normal function of the facility's daily operation.

3.5 INSTALLATION

- A. Install fire suppression equipment to permit easy access for normal maintenance, and so that parts requiring periodic replacement or maintenance, (e.g., coils, heat exchanger bundles, sheaves, filters, meters, bearings, etc.) can be removed. Relocate items which interfere with access.
- B. Provide access doors in equipment, ducts, and walls/ceilings as required to allow for inspection and proper maintenance.
- C. If circumstances at a particular location make the accessible installation of an item difficult or inconvenient, the situation shall be discussed with the Engineer before installing the item in a poor access location.
- D. Belts, pulleys, couplings, projecting set screws, keys and other rotating parts which may pose a danger to personnel, shall be fully enclosed or guarded in accordance with OSHA regulations.
- E. Dissimilar Metals: Provide separations between all dissimilar metals. Where not specified in another way, use 10 mil black plastic tape wrapped at point of contact or plastic centering inserts.
- F. Provide offsets around all electrical panels (and similar electrical equipment) to maintain space clear above and below panel to structure and clearance of 3 feet directly in front of panel, except where indicated otherwise or required by NEC to be more. Such offsets are typically not shown on the drawings, but are required per this paragraph.
- G. Safety Protection: All ductwork, piping and related items installed by this Contractor that present a safety hazard (i.e., items installed at/near head height, items projecting into maintenance access paths, etc.) shall be covered (at hazardous area) with 3/4" thick elastomeric insulation and 2" wide reflective red/white striped self-sticking safety tape.
- H. Equipment Access: Access to equipment is of utmost importance. Contractor shall apply extra attention to the laying out of pipe and duct routings, and in coordinating all work. Poor access to equipment will not be accepted. Contractor shall note that in essentially all areas, piping routed in ceiling space needs to run in joist space, necessitating elbows/fittings/transitions at crosses with other trades, at structural beams, and at all connections to mains and branches. Dashed areas at HVAC units indicate equipment access areas. These (and all other) access areas shall be clear of obstructions. The Division 15 contractor is responsible to coordinate and insure that all trades stay clear of access areas for any Division 15 furnished equipment.
- I. Insure that items to be furnished fit space available. Make necessary field measurements to ascertain space requirements including those for connections and furnish and install equipment of size and shape so final installation shall suit true intent and meaning of Contract Documents.

**NISQUALLY STATE PARK
NEW FULL SERVICE PARK – PHASE 2**

3.6 ADJUSTMENT AND CLEANING

- A. Properly lubricate equipment before Owner's acceptance.
- B. Clean exposed piping, ductwork, equipment, and fixtures, remove debris from site. Repair damaged finishes and leave everything in working order.
- C. All work areas shall be left broom clean and free of debris. Sweep mechanical rooms at completion of work, and dispose of waste. Dispose of all existing waste in mechanical rooms in addition to waste generated by this work.

3.7 COMMISSIONING

- A. The Contractor has specific responsibilities relating to demonstrating the equipment and systems provided have been installed and function per the contract specifications. These responsibilities include, but are not limited to the following:
 - 1. Complete all equipment and system start-up and checkout procedures, and to insure the complete readiness of equipment and systems, prior to the start of the functional performance testing phase of the commissioning process.
 - 2. Functional test all fire suppression systems in accordance with Local Code. Demonstrate system performance to the Engineer.
 - 3. Provide to the Owner written results of the functional performance testing.
- B. Owner shall not accept equipment and systems, and Owner shall not make final payment, until all equipment and systems have been successfully commissioned and all specified requirements have been satisfied.

END OF SECTION

**NISQUALLY STATE PARK
NEW FULL SERVICE PARK – PHASE 2**

SECTION 211000 – FIRE SPRINKLER SYSTEM

PART 1 - GENERAL

1.1 WORK INCLUDED

- A. Sprinkler System Design.
- B. Calculation of Sprinkler System.
- C. Piping.
- D. Valves.
- E. Sprinkler Heads.
- F. Accessories.
- G. Owner Instruction.

1.2 QUALITY ASSURANCE

- A. All materials and equipment shall be listed as approved by the Underwriters' Laboratories "List of Inspected Fire Protection Equipment and Materials", or the Factory Mutual Laboratories, "List of Inspected Fire Protection Equipment and Materials", or the Factory Mutual Laboratories, "List of Approved Equipment, Fire Protection Devices and Devices Involving Fire Hazard"; and shall be of the Manufacturer's latest design.
- B. Equipment and installation to meet requirements of NFPA 13, Standard for the installation of Sprinkler Systems and all other governing codes (see Section 210500), and to exceed these codes as indicated. Various items in these specifications exceed code requirements.

1.3 SUBMITTALS

- A. All submittals shall comply with Section 210500.
- B. Submit shop drawings of entire sprinkler system for approval by the local Fire Marshal. Submit Fire Marshal approved drawings to Architect/Engineer. Shop drawings shall show head locations on reflected ceiling plans; use shop drawings from ceiling installer for ceiling layout. Shop drawings shall also show ductwork along with sprinkler piping; use shop drawings from sheet metal contractor or contract drawings if no sheet metal shop drawings are provided.
- C. Submit product information on all products to be used.
- D. Shop drawings shall be submitted within 120 days after the notice to proceed.

**NISQUALLY STATE PARK
NEW FULL SERVICE PARK – PHASE 2**

1.4 GENERAL REQUIREMENTS

- A. All fire sprinkler design shall be performed by a Contractor thoroughly familiar with and knowledgeable of NFPA 13, NFPA 24 and fire sprinkler system design and installation. By virtue of submitting a bid, the Contractor is acknowledging that he does in fact have such knowledge; and all work provided will fully comply with all the requirements of these specifications. The fire sprinkler Contractor shall be qualified, as required by local authorities to design and install all parts of the fire sprinkler system.
- B. All fire sprinkler design drawings shall be stamped by a Washington State Licensed Fire Protection Engineer, or Fire Sprinkler Designer acceptable to the reviewing code authority. The fire sprinkler system shall be designed by persons or firms certified as level III competency holders by the State of Washington. The designing firm shall be direct responsible to the installing contractor (for all products).
- C. System shall be Contractor-designed and approved by both the Fire Marshal and Architect/Engineer.
- D. System Description: Provide a new dry pipe fire sprinkler system covering all areas of the building. All spaces shall be sprinklered, including all concealed combustible spaces and above and below all ceilings. Some fire sprinkler coverage is called for that exceeds code requirements, and shall be provided as noted.
- E. This section alone does not specify all work for the fire sprinkler system. Other sections which include fire sprinkler work are: 210500; the Contractor is responsible to review all sections. Other divisions may also describe related fire sprinkler work, the Contractor is responsible to review all divisions.
- F. Special Design Areas: Portions of the building's fire sprinkler system where the fire sprinkler piping is to be run exposed or requires drilling through building structure require special design effort, and coordination among trades and with the Authority Having Jurisdiction (AHJ) and the design team. The Contractor shall include in his bid costs for such special coordination and design efforts. This work shall include multiple meeting with local and state code officials, various contractors, and members of the design team.

PART 2 - PRODUCTS

2.1 ACCEPTABLE MANUFACTURERS

- A. All products shall comply with Section 210500, Acceptable Manufacturers.
- B. Sprinkler System Components: Reliable, Viking, Potter Roemer, Gem, Star, Victaulic, Sprink, Mech-Line, Central, Grinnell.
- C. Valves: Crane, Grinnell, Potter Roemer, Viking, Gem, Victaulic, Kennedy, Central.

**NISQUALLY STATE PARK
NEW FULL SERVICE PARK – PHASE 2**

2.2 PIPE AND PIPE FITTINGS

- A. Aboveground Piping and Fittings: Piping shall be schedule 40 black steel. Fittings shall be suitable for 175 psi working pressure, and shall be cast iron or malleable iron screwed, grooved or welded in accordance with NFPA 13. Piping and fittings ran outside and exposed to the outdoors shall be galvanized type. (i.e. if piping is concealed in soffit, galvanized is not required.)
- B. Underground Piping and Fittings: Shall conform to local utility requirements, NFPA 24 and NFPA 13. Shall be ductile iron pipe conforming to AWWA C151, thickness class 52 minimum. Fittings shall conform to AWWA C111, with pressure rating no less than the piping connected to. Pipe and Fittings shall have cement-mortar lining conforming to AWWA C104. Pipe and fittings shall be restrained against movement in accordance with NFPA 24. Thrust restraining joints/fittings shall be UL listed for fire main use.

2.3 VALVES

- A. 2 Inch and Smaller: Bronze gate valve, 175 psi water working pressure, threaded ends conforming to ANSI Standard B2.1, UL listed and FM approved. Stockham Figure B-133, or approved. Contractor Option: Bronze butterfly or ball valve, UL listed for fire protection service and FM approved. Milwaukee or equal.
- B. 2-1/2 Inch and Larger:
 - 1. OS & Y Type: Iron body OS & Y gate valve, 175 psi non-shock cold water, flanged ends conforming to ANSI Standard for Class 125 cast iron flanges B16.1, UL listed and FM approved. Stockham Figure G-634, or approved. (Provide with tapping for corporation stop matching detector check valve where valve is used upstream of detector check.)
 - 2. NRS Type: Iron body NRS gate valve, 175 psi non-shock cold water, flanged or mechanical joint ends, bronze mounted, with indicator post flange, UL listed and FM approved. Stockham Figures G-632, G-635, or approved (for use with wall or post indicator only).
- C. Check Valves: Iron body swing check valve, 175 psi non-shock cold water, UL listed and FM approved. Stockham Figures G-938, G-940, or approved.
- D. Indicator Posts: Shall be UL listed and FM approved, of cast iron construction, with operating wrench, lock means, identification plates indicating valve open/shut, adjustable sleeve, sections to suit varying buried depths, tapped for supervisory, extension rod, base to match valve used with, and bright red factory enamel paint finish.
- E. Automatic Ball Drip Valve: Straight or angle cast brass ball, drip, 1/2 Potter-Roemer Series 5980 or approved.

2.4 ALARM VALVES--DRY PIPE

- A. Alarm valve shall be UL listed and FM approved for use as an alarm valve in a dry pipe fire sprinkler system, size as selected by Contractor.

**NISQUALLY STATE PARK
NEW FULL SERVICE PARK – PHASE 2**

- B. Alarm valve shall be complete with accelerator, pressure gauges, main drain valve, pressure alarm switch, alarm test valving, priming connections, drain lines/drain cup, connections for water motor alarm, check and isolation valves for air line connection, air line relief valve and all other accessories to provide a complete alarm valve assembly as required to function in accordance with NFPA standards.

2.5 ALARM BELLS

- A. Electric Type: 24 V Dc electric alarm shall sound continuous ringing alarm when water is flowing in the fire sprinkler system. Shall be compatible with flow switch furnished, be UL listed and FM approved.
- B. Labeling: Alarm bells shall be labeled or provided with sign mounted adjacent to bell, reading "Sprinkler Fire Alarm" (in 1-inch high capital letters), followed by "when bell rings, call Fire Department or Police." Sign shall be aluminum lithographed, with red letters on white background.

2.6 SPRINKLER HEADS

- A. Dry Type:
 - 1. General: Provide where system may be exposed to freezing temperatures, finish, length and temperature rating to suit application. Heads in occupied areas shall be quick response type.
 - 2. Finished Areas: Polished chrome finish type with flush type chrome plated escutcheon where installed through ceilings, soffits, and similar elements.
 - 3. Unfinished Areas: Natural bronze finish with flush or deep type brass finish escutcheon where installed through a floor, ceiling, or similar element.
 - 4. Sprinkler Guards: Hard-wire cage sprinkler guard, designed to protect sprinkler from mechanical damage, with chrome plated finish.
 - 5. Sprinkler heads shall be upright, pendant or sidewall type as required to suit application.
 - 6. See Section 220500 for definition of "Finished Areas", and "Occupied Areas".

2.7 ACCESSORIES

- A. Waterflow Alarm - Flow Type Indicator: Shall be UL listed, with polyethylene paddle water flow detector, cast metal body, adjustable time delay retard mechanism to allow indicator to absorb fluctuations of water flow due to pressure surges to prevent false alarms.
- B. Waterflow Alarm - Pressure Type: Furnished with Alarm valve, see paragraph entitled "Alarm Valves--Dry Pipe". Switch shall indicate activation of sprinkler system.
- C. Low Pressure Air Alarm Switch: Single pole double throw switch, for indicating low air pressure supplied to a dry pipe system. Shall be rated for 250 psi service pressure, be enclosed in a NEMA 2 housing, have a neoprene diaphragm, and be field adjustable between 20 and 225 psi.
- D. Valve Switches: Switch for indicating operation of valve; type and configuration to suit valve used on. Switch shall have single pole, double throw type contacts, with cast aluminum housing

**NISQUALLY STATE PARK
NEW FULL SERVICE PARK – PHASE 2**

and non-ferrous parts for corrosion resistance. Shall be weatherproof type where installed outdoors.

- E. Sway Bracing/Restraints: Contractor fabricated of riser clamps, Schedule 40 pipe and pipe fittings, all welded construction, size and configuration to suit application.
- F. Specialties: Access doors, gauges, and related piping specialties; see Section 210500.
- G. Hangers/Supports: See Section 220529.
- H. Sleeves/Seals: See Section 220530.
- I. Air Compressor:
 - 1. Sizing: Shall be by Contractor, in compliance with NFPA requirements.
 - 2. Type: Air compressor shall be electric motor-driven, air cooled, single-stage, tank mounted type. Tank shall be ASME labeled. Unit shall be complete with connections for controlling unit On/Off, motor starter, disconnect, vibration isolators, relief valve, pressure gauge outlet isolation valve, outlet union, and related accessories for proper unit operation.
 - 3. Power: Unit shall be no larger than 3/4 HP, and shall be for use with 120 volt/1 PH electricity, and shall have single point power connection.
 - 4. Noise: Compressor noise shall not exceed NC 35 in any octave band. Provide acoustic enclosure or remote piped air intake with a muffler to reduce noise as required.
- J. Air Maintenance Assembly: Shall be type for use with dedicated sprinkler system air compressor. Assembly shall include air line strainer, air pressure switch for compressor control, bypass globe valve, isolation valves, unions, and all related components to properly connect the air compressor to the dry pipe system, in compliance with NFPA and local code requirements.

PART 3 - EXECUTION

3.1 INSTALLATION

- A. Installation of all equipment shall be performed by a Contractor specializing in this work and subject to Owner and Fire Marshal approval.
- B. All piping shall be run concealed in ceiling space, attic space, pipe shafts, soffits, etc. Provide all necessary drilling of beams, trusses, etc. Structural Engineer's approval is required. Piping may only be exposed with Engineers approval and then shall be painted as directed by the Architect/Engineer. Piping shall run parallel to building structure in a neat, workmanlike manner.
- C. Provide chrome plated escutcheon plates at exposed pipe penetrations of all ceilings, floors and walls.
- D. Where piping is below grade, it shall not be insulated, but it shall be painted with a heavy coat of bitumastic paint.

**NISQUALLY STATE PARK
NEW FULL SERVICE PARK – PHASE 2**

- E. Electrical, mechanical, architectural and structural plans shall be carefully examined by the Sprinkler Contractor, and his work shall be arranged to avoid interferences and to comply with all related requirements on these drawings.
- F. If piping routes are not properly coordinated with other trades and structures, rerouting and possible re-sizing will be required as directed by the Architect/Engineer. The fire piping system has lowest priority of all systems routed in ceiling space.
- G. Offset, crossover and otherwise route piping to install system in available space. Not all offsets necessarily shown. Pitch all branch lines, cross mains, feed mains and risers to drainage points.
- H. Special care shall be taken to insure that entire sprinkler system is drainable in accordance with NFPA 13. Any work without proper slope to drain will be rejected. Where space permits, increase slope to 1 inch per 10 feet.
- I. Labeling: All drain valves, alarm bells, and risers shall be labeled to clearly indicate purpose/area served, per NFPA requirements and as specified herein. Risers shall be labeled to indicate hydraulic calculation basis.
- J. Tamper Switches: Provide valve tamper switches at all isolation valves, and as required by the local Fire Marshal to indicate valves not fully open. Connection to central fire alarm system shall be by Division 26.
- K. Heads shall be centered in ceiling panels. Where "scored" ceiling panels are used, heads shall be located to be centered in the flat portion of the tile between "scores".
- L. Provide wire cage protectors where indicated on drawings and for heads susceptible to damage (this includes all heads in mechanical loft areas with sprinkler heads 7 feet or less above walking surface, outside soffit heads below 9', and similar areas).
- M. Provide shields to divert sprinkler water from equipment (i.e. electrical panels) which may be damaged (typical all areas).
- N. Hangers and Supports: Shall comply with NFPA 13 and Section 220529. See also structural drawings for added limitations/requirements of supports and attachments to structure.
- O. Contractor shall use caution in routing of wet pipe lines to maintain distances from outside walls and other areas which could have freezing temperatures in extreme conditions.
- P. Pipe Routing: Contractor shall in no way interfere with mechanical access, and shall maintain 7' clear headroom at all locations over platforms at mechanical equipment (unless structurally prohibited). Provide separate mains to serve corridors and areas below attic platform -piping that runs on platform or interferes with access will not be accepted.
- Q. Air Compressor: Install and connect up air compressor piping and accessories to system and provide all wiring interconnections between controller and compressor. Install compressor on vibration isolators.
- R. Provide building access doors as needed to allow maintenance access to all sprinkler heads and system components. Doors shall be no smaller than 24" x 24". Note: This is in excess of NFPA 13 requirements. Reference Section 220500 for access door requirements. Coordinate with other

**NISQUALLY STATE PARK
NEW FULL SERVICE PARK – PHASE 2**

trades for proper framing/block-out provisions to accommodate doors, and to insure no other systems block door access.

3.2 SYSTEM DESIGN

- A. System shall be Contractor designed in accordance with NFPA 13, and additional requirements as cited in the Contract Documents.
- B. System design shall be based on hydraulic calculations using approved water flow test data on the water supply line to the fire protection system. Such test data must meet the approval of the local Fire Marshal and the Architect/Engineer. Water flow data is shown on the plans is preliminary only. Contractor is responsible to arrange for such water flow tests and pay all associated fees for such a test.
- C. Submit all system calculations showing calculations and compliance with NFPA.
- D. Design shall include complete system, including water main to building, and extending as far back into the local utilities systems (i.e. reservoirs) as deemed necessary by the AHJ.

3.3 TESTING

- A. The systems shall be hydrostatically and operationally tested in accordance with the requirements of NFPA 13 and the local Fire Marshal. Any changes required to meet time or flow tests shall be made without additional cost to the Owner. Certificates of acceptance shall be submitted to the Architect/Engineer.

3.4 OPERATING AND OWNER INSTRUCTIONS

- A. Typewritten, plastic covered, framed instructions shall be mounted in the buildings near each fire sprinkler riser. Instructions shall explain riser components, how to test, and how to drain.
- B. The Owner or his representative shall be instructed by the Sprinkler Contractor in the operation of the system. The instruction shall be given by Contractor's personnel who are considered qualified in the opinion of the Architect/Engineer and shall be for a minimum of two (2) hours. Instruction shall include location of all valves, drains, and pipe routing, as well as proper maintenance and testing procedures.

END OF SECTION

**NISQUALLY STATE PARK
NEW FULL SERVICE PARK – PHASE 2**

SECTION 220500 – GENERAL PLUMBING REQUIREMENTS

PART 1 - GENERAL

1.1 WORK INCLUDED

- A. General Plumbing Requirements.
- B. Plumbing Submittals.
- C. Motors.
- D. Equipment and Piping Identification.
- E. Commissioning.

1.2 GENERAL

- A. Includes, but not limited to, furnishing labor, materials, and equipment for completion of work unless indicated or noted otherwise.
- B. All work included in Division 22 shall be the responsibility of a single Plumbing Subcontractor. This Contractor shall obtain and pay for all permits required by State and local authorities governing the installation of the plumbing work. It is the Contractor's responsibility to contact all utility organizations serving the building, prior to bid, and to include all charges for inspections, installation of materials, equipment and connection of all required utilities.
- C. The drawings and specifications are complementary and what is called for in either is binding as if called for in both.
- D. All plumbing equipment and devices furnished or installed under other Divisions of this specification which require connection to any plumbing systems (i.e., plumbing systems or duct systems, or controls) shall be connected under this division of the Specifications.
- E. The Contractor shall be responsible for checking field conditions and verifying all measurements and relationships indicated on the drawings before proceeding with the work.

1.3 ELECTRICAL

- A. All equipment with an electrical connection shall be factory wired to a junction box for connection to electrical service.
- B. Where a piece of equipment specified includes an electric motor, the motor shall be furnished and mounted by this Contractor. Motor starter, disconnect switches and wiring from the electrical panel to the motor control devices and to the motor shall be provided by the Division 26 Contractor unless stated otherwise in the mechanical specification and on the plumbing equipment schedule.

**NISQUALLY STATE PARK
NEW FULL SERVICE PARK – PHASE 2**

1.4 SYSTEMS DESCRIPTION

A. Site Inspection:

1. Examine premises and understand the conditions which may affect performance of work of this Division before submitting proposals for this work.
2. No subsequent allowance for time or money will be considered for any consequence related to failure to examine site conditions.

B. Drawings:

1. Plumbing drawings show general arrangement of piping, equipment, etc. Follow as closely as actual building construction and work of other trades will permit.
2. Consider electrical drawings part of this work insofar as these drawings furnish information relating to design and construction of building.
3. Because of small scale of plumbing drawings, it is not possible to indicate all offsets, fittings, and accessories which may be required. Investigate structural and finish conditions affecting this work and arrange work accordingly, providing such fittings, valves, and accessories required to meet conditions.

1.5 SUBMITTALS

- A. All material used on the project shall be new and free of defects. The Engineer reserves the right to reject any material, the appearance of which has been damaged on the site or in shipment. The material shall be of approved equal quality to that which is specified. Should the make and type of material differ from that specified, the Contractor may be required to submit catalog and engineering data (samples if requested) necessary to make a comparison and determine its suitability. The Contractor shall also bear the cost of any changes to the plumbing design made necessary by any approved substitutions.
- B. The Contractor shall submit to the Engineer, for approval, complete information on all equipment and materials to be provided on the project including six copies of the manufacturer's catalog and engineering data, shop drawings of shop fabricated equipment and instruction data for each item included under this section of the specifications. Submittals shall be presented to the Engineer within 30 calendar days from the date of the contract signing in complete indexed and bound sets. The Contractor shall submit a typed, signed list including all items to be furnished on the project. The signature on the aforementioned list shall indicate that the contractor has examined the suitability of all material and equipment with respect to compliance with these specifications. The Contractor's approval shall also indicate that physical dimensions of the equipment have been verified with the installation requirements and were found to cause no interference therewith.
- C. Review of submittal data by the Engineer or Engineers does not relieve the Contractor of responsibility for quantities, measurements, and compliance with the intent of all contract documents.
- D. Furnish submittals on all items and equipment specified in Division 22 and all items indicated on plumbing drawings in a hard-back, three-ring binder:
- E. The Contractor shall submit the plumbing cost breakdown including all sub-contractors costs.

**NISQUALLY STATE PARK
NEW FULL SERVICE PARK – PHASE 2**

1.6 OPERATION AND MAINTENANCE MANUAL FOR PLUMBING SYSTEMS

- A. Bind Operation & Maintenance Manual for Plumbing Systems in three-ring, hard-backed binder with clear plastic pocket on spine. Spine of each binder shall have following typewritten lettering inserted:

**OPERATION AND MAINTENANCE MANUAL
FOR PLUMBING SYSTEMS**

- B. Provide master index at beginning of Manual showing items included. Use plastic tab indexes for sections of Manual.
- C. First section shall consist of name, address, and phone number of Engineer, General Contractor, and Mechanical, Plumbing, Sheet Metal, Refrigeration, Temperature control, and Electrical subcontractors. Also include complete list of equipment installed with name, address, and phone number of each vendor.
- D. Provide section for each type of item of equipment.
- E. Submit copies of Operation & Maintenance Manual to Engineer for approval.
- F. Include descriptive literature (Manufacturer's catalog data) of each manufactured item. Literature shall show capacities and size of equipment used and be marked indicating each specific item with applicable data underlined.
- G. Operating Instructions shall include:
1. General description of each plumbing system.
 2. Step-by-step procedure to follow in putting each piece of plumbing equipment into operation.
- H. Maintenance Instructions shall include:
1. Manufacturer's maintenance instructions for each piece of plumbing equipment installed in Project. Instructions shall include name of vendor, installation instructions, parts numbers and lists operation instructions of equipment, and maintenance and lubrication instruction.
 2. Summary list of plumbing equipment requiring lubrication showing name of equipment, location, and type and frequency of lubrication.
 3. List of plumbing equipment used indicating name, model, serial number, and nameplate data of each item together with number and name associated with each system item.

1.7 QUALITY ASSURANCE:

- A. Requirements of Regulatory Agencies:
1. Perform work in accordance with applicable Codes.
 2. In case of differences between building codes, state laws, local ordinances, utility company regulations, and Contract Documents, the most stringent shall govern.
- B. Product Approvals: See paragraphs elsewhere in this specification.

**NISQUALLY STATE PARK
NEW FULL SERVICE PARK – PHASE 2**

- C. Manufacture: Use domestic made pipe, pipe fittings, and motors on project.
- D. Identification: Motor and equipment name plates as well as applicable UL and AGA labels shall be in place when project is turned over to Owner.

1.8 CODES AND STANDARDS

- A. Codes and agencies having jurisdictional authority over plumbing installation.
- B. Washington State Energy Code
- C. International Building Code -- Latest Approved Edition
- D. International Mechanical Code -- Latest Approved Edition
- E. Uniform Plumbing Code -- Latest Approved Edition
- F. Local Sewer and Water District Requirements
- G. State and County Department of Health
- H. Occupational Safety and Health Administration (OSHA)

1.9 PRODUCT HANDLING AND PROTECTION:

- A. Contractor is responsible for protection of all material, equipment and apparatus provided under this section from damage, water, corrosion, freezing and dust, both in storage and when installed, until final project acceptance.
- B. Provide temporary heated and sheltered storage facilities for material and equipment.
- C. Completely cover motors and other moving machinery to protect from dirt and water during construction.
- D. Handle and protect equipment and/or material in manner precluding unnecessary fire hazard.
- E. Equipment requiring rotation and/or lubrication during storage shall have records maintained and witnessed on a monthly basis and forwarded to the Engineer prior to acceptance.
- F. Material or equipment damaged because of improper storage or protection will be rejected.
- G. Equipment finish that is damaged by handling, storage, etc. shall be corrected by the Contractor at no additional cost to the Owner.

1.10 WARRANTIES:

- A. In addition to guarantee specified in General Conditions, guarantee plumbing systems to be free from noise in operation that may develop from failure to construct system in accordance with Contract Documents.

**NISQUALLY STATE PARK
NEW FULL SERVICE PARK – PHASE 2**

- B. In order to be protected, secure proper guarantees from suppliers and subcontractors.
- C. Provide certificates of warranty for each piece of equipment. Clearly record "start-up" date of each piece of equipment on certificate. Include certificates as part of Operation & Maintenance Manual.

1.11 ABBREVIATIONS:

- | | | |
|-----|--|---|
| 1. | AFF | Above Finish Floor |
| 2. | AMCA | Air Moving & Conditioning Association |
| 3. | ANSI | American National Standards Institute |
| 4. | APWA | American Public Works Association |
| 5. | ARI | Air Conditioning and Refrigeration Institute |
| 6. | ASHRAE | American Society of Heating, Refrigerating and Air Conditioning Engineers |
| 7. | ASME | American Society of Mechanical Engineers |
| 8. | ASTM | American Society of Testing & Materials |
| 9. | AWWA | American Water Works Association |
| 10. | BFF | Below Finish Floor |
| 11. | BHP | Brake Horsepower |
| 12. | BTU | British Thermal Unit |
| 13. | CFC | Chloro - Fluorocarbon |
| 14. | CFM | Cubic Feet per Minute |
| 15. | DOT | US Department of Transportation |
| 16. | EPA | Environmental Protection Agency |
| 17. | fpm | feet per minute |
| 18. | FS or Fed. | Spec. Federal Specifications |
| 19. | HP | Horsepower |
| 20. | IEEE | Institute of Electrical and Electronics Engineers |
| 21. | KW | Kilowatt |
| 22. | MBH | One Thousand British Thermal Units per Hour |
| 23. | MS or Mil.Spec. | Military Specifications |
| 24. | MSS | Manufacturers Standardization Society |
| 25. | NEC | National Electrical Code |
| 26. | NEMA | National Electrical Manufacturers Association |
| 27. | per | in accordance with |
| 28. | PVC | Polyvinyl Chloride |
| 29. | SMACNA | Sheet Metal and Air Conditioning Contractors National Association |
| 30. | SP | Static Pressure |
| 31. | UL | Underwriter's Laboratories |
| 32. | w.g. | Water Gauge (inches of water) |
| 33. | WQA | Water Quality Association |
| 34. | Additional abbreviations are as listed on the drawings or elsewhere in these specifications. | |

1.12 DEFINITIONS:

- A. Finished Spaces: Spaces used for habitation or occupancy where rough surfaces are plastered, paneled, or otherwise treated to provide a pleasing appearance.

**NISQUALLY STATE PARK
NEW FULL SERVICE PARK – PHASE 2**

- B. Unfinished Spaces: Spaces used for storage or work areas where appearance is not a factor.
- C. Concealed Spaces: Spaces out of sight. For example, above ceilings; below floors; between double walls; furred-in areas; pipe and duct shafts; and similar spaces.
- D. Exposed: Open to view. For example, pipe running through a room and not covered by other construction.
- E. Outside: Open to view up to 5 feet beyond the exterior side of walls, above the roof, and unexcavated or crawl spaces.
- F. Conditioned Space: An area, room or space normally occupied and being heated or cooled for human habitation by any equipment.

PART 2 - PRODUCTS

2.1 ACCEPTABLE MANUFACTURERS:

- A. Any reference to the specifications or on the drawings to any article, device, product, material, fixture, form or type of construction by manufacturer, name, make, or catalog number shall be interpreted as establishing a standard of quality and shall not be construed as limiting competition.
- B. The manufacturer listed as Acceptable Manufacturers are approved for the items indicated without obtaining prior approval. Other manufacturers require prior approval.
- C. The listing of a manufacturer as an Acceptable Manufacturer does not necessarily mean that the products of that manufacturer are equal to those specified. The listing is only an indication of those manufacturers which may be capable of manufacturing, or have in the past manufactured, items equal to those specified, and is intended to aid the Contractor in identifying manufacturers.
- D. Products provided by Acceptable Manufacturers shall be equal to or superior to the specified manufacturer's item in function, appearance, and quality, and shall fulfill all requirements of the plans and specifications. The Engineer shall be the final judge as to whether an item meets these requirements or not. If a manufacturer is not certain that his product meets these requirements or not, then the manufacturer shall submit data as required to obtain the Design Consultant's approval.
- E. The approval of a manufacturer applies to the manufacturer only and does not relieve the Contractor from the responsibility of meeting all applicable requirements of the plans and specifications.
- F. Contractor shall be responsible for all costs to other trades and all revisions required to accommodate any products which are different than those specified or shown.
- G. In reviewing a manufacturer for acceptance, factors considered include the following: engineering data showing item's performance, proper local representation of manufacturer, likelihood of future manufacturer's local support of product, service availability, previous installation, previous use by Owner/Engineer and record, product quality, availability/quality of maintenance and

**NISQUALLY STATE PARK
NEW FULL SERVICE PARK – PHASE 2**

operation data, capacity/performance compared to specified items, acoustics, items geometry/access utility needs, and similar concerns.

- H. If approval is received to use other than specified items, responsibility for specified capacities and insuring that items to be furnished will fit space available lies with this Division.
- I. If non-specified equipment is used and it will not fit job site conditions, this Division assumes responsibility for replacement with items named in Specification.

2.2 ACCESS DOORS

- A. This contractor shall be responsible for furnishing and installing flush mounted access doors in walls, ceiling and floors and chases where the following equipment is concealed and is not accessible through same.
 - 1. Valves (shut off)
 - 2. Trap Primers
- B. Doors shall be UL listed 16 ga. cold rolled steel with concealed hinge, screwdriver operated lock and prime coated. Furnish suitable for area mounted.
- C. Approved Manufacturers:
 - 1. Milcor
 - 2. Karp
 - 3. Greenheck

2.3 EQUIPMENT AND PIPING IDENTIFICATION

- A. General: All piping, valves, and plumbing equipment shall be marked. All markings in concealed accessible spaces shall be reviewed and verified by Architect/Engineer prior to being concealed.
- B. Piping: Piping shall be marked as follows:
 - 1. Type: Self-sticking colored markers, lettered to identify the pipe contents, and banded at each end with arrow tape indicating the direction of flow. Markers shall be similar and equal to Brady "System 1" and Seton "Opti-Code" markers. Spray painted stencil labeling is not acceptable. Some markers may be special order.
 - 2. Marker Colors and Wording:

Piping System & Wording	Background	Letters
Domestic Cold Water	White	Green
Domestic Hot Water	White	Red
 - 3. Marker Lettering: Lettering shall identify the material conveyed in each pipe. Systems which have supply and return piping shall have piping labeled as such (i.e. domestic hot water etc.). Size of letters and color field shall comply with ANSI A13.1., repeated here for convenience:

**NISQUALLY STATE PARK
NEW FULL SERVICE PARK – PHASE 2**

Outside Diameter of Pipe or Covering	Length of Color Field	Size of Letters
3/4 to 1-1/4 Inches	8 Inches	1/2 Inches
1-1/2 to 2 Inches	8 Inches	3/4 Inches
2-1/2 to 6 Inches	12 Inches	1-1/4 Inches

4. Locations: Markers shall be installed on all exposed piping adjacent to each shut-off valve, at branches to indicate changes of direction, where pipes pass through walls and floors, on 20 foot centers or at least one in each room on each pipe. Markers shall be installed on all concealed accessible piping (i.e., piping above suspended ceilings, behind access doors, in accessible chases, etc.) near the point of access, except that, for piping above suspended ceilings, markers shall be installed the same as if the piping was exposed (i.e., same as if the suspended ceiling was not in place). Markers shall be installed so as to easily read by a person standing on the floor. Provide additional direction of flow arrows at each pipe connections at all control valves.
- C. Valves shall be marked as follows:
1. Identification tags made of brass or aluminum, stamped with valve number and abbreviation of system served (HTG, PLBG, CW, HW, GAS, AC). Tags shall be installed on all valves except stops at plumbing fixtures. Tags shall be not less than 1-1/2 inch in diameter, markings shall be stamped and black filled, and lettering shall be minimum 1/4-inch high with numbers minimum 1/2-inch high. Tags shall be wired to each valve with No. 6 polished nickel-steel jack chain.
- D. All plumbing equipment which was scheduled on the Contract Drawings shall be marked with the name of the item; i.e., Pump No. 1 etc. The identification shall be the same as shown on the Contract Drawings. The marking shall be located on two different sides of the equipment so as to be easily read, with at least one marking visible to a person standing at floor level near the unit (assuming any necessary access to a concealed unit has been made). Lettering shall be a minimum of 2" high. Marking shall be with engraved phenolic labels, white letters on black background. Equipment marking is not required for; air outlets and inlets, plumbing fixtures.
- E. All mechanical control equipment shall be marked with phenolic labels. Equipment shall be marked to match the tags used in the programming of the control equipment.

PART 3 - EXECUTION

3.1 WORKMANSHIP

- A. This Contractor shall provide completed systems with a neat and finished appearance. If, in the judgment of the Engineer, any portion of the work has not been performed in a workmanlike manner or is left in a rough, unfinished state, this Contractor will be required to remove, reinstall or replace same and patch and paint surrounding surfaces in a manner acceptable to the Engineer, without increase in cost to the Owner.

3.2 CLOSEOUT SUBMITTALS

**NISQUALLY STATE PARK
NEW FULL SERVICE PARK – PHASE 2**

- A. Requirements: Final approval of plumbing installation will be recommended upon completion of the following:
1. Completion of all punchlist items
 2. Operation instruction period to Owner's satisfaction
 3. Permit Submittal
 4. Valve list posted
 5. Reproducible As-Built drawings delivered to Engineer
 6. Asbestos Free Statement
 7. Guarantees
 8. Equipment Manufacturer of all plumbing units shall provide start-up logs.

3.3 FINAL INSPECTION

- A. Final Inspection:
1. Prior to acceptance of the plumbing work, the Contractor shall put all plumbing systems into operation for a period of not less than 5 working days so that they may be inspected by the Engineer and the Owner's representatives.
 2. The time of the final inspection shall be mutually agreed to by the Owner, Engineer, and Contractor.
 3. The Contractor shall furnish adequate staff to operate the plumbing systems during inspection.

3.4 OPERATION AND MAINTENANCE TRAINING

- A. Upon completion of the work, and after all tests and final inspection of the work by the Authority(s) having jurisdiction, the Contractor shall demonstrate and instruct the Owner's designated operation and maintenance personnel in the operation and maintenance of the various plumbing systems. The Contractor shall arrange scheduled instruction periods with the Owner. The Contractor's representatives shall be Superintendents or Foremen knowledgeable in each system and Supplier's Representative when so specified.
- B. Costs for time involved by Contractor shall be included in the bid.

3.5 PREPARATION

- A. Existing Buildings:
1. Cut carefully to minimize necessity for repairs to existing work. Do not cut beams, columns, or trusses.
 2. Patch and repair walls, floors, ceilings, and roofs with materials of same quality and appearance as adjacent surfaces unless otherwise shown.
 3. This work shall be scheduled such that utility services and/or existing systems for the facility are not interrupted during normal operating hours, without prior written permission of the Owner's representative. Work that is performed during normal operational hours shall not interfere with the normal function of the facility's daily operation.

**NISQUALLY STATE PARK
NEW FULL SERVICE PARK – PHASE 2**

4. The Plumbing Contractor shall be responsible for the removal of all existing plumbing equipment and utilities indicated to be removed on the drawings. The Plumbing Contractor shall also be responsible for the removal and reinstallation of all existing plumbing equipment and utilities that will interfere with installation and operation of any new construction indicated or required and shall be responsible for the removal of all existing plumbing equipment and utilities indicated to be abandoned that will interfere with installation and operation of any new construction indicated or required. All plumbing equipment (other than piping) to be removed shall remain the property of the Owner, and shall be transported - stored - or disposed of, as directed by the Owner. This will be at no cost to the Owner.
5. The Plumbing Contractor shall provide proof of EPA certified training and EPA registered and tested recovery and recycling equipment with his initial submittals. The Contractor shall evacuate, store, transport, and reclaim all CFC's evacuated from any of the units scheduled for removal to the ARI purity standard.

3.6 INSTALLATION

- A. Install plumbing equipment to permit easy access for normal maintenance, and so that parts requiring periodic replacement or maintenance, (e.g., coils, heat exchanger bundles, sheaves, filters, meters, bearings, etc.) can be removed. Relocate items which interfere with access.
- B. Provide access doors in equipment, ducts, and walls/ceilings as required to allow for inspection and proper maintenance.
- C. If circumstances at a particular location make the accessible installation of an item difficult or inconvenient, the situation shall be discussed with the Engineer before installing the item in a poor access location.
- D. Belts, pulleys, couplings, projecting set screws, keys and other rotating parts which may pose a danger to personnel, shall be fully enclosed or guarded in accordance with OSHA regulations.
- E. Dissimilar Metals: Provide separations between all dissimilar metals. Where not specified in another way, use 10 mil black plastic tape wrapped at point of contact or plastic centering inserts.
- F. Provide offsets around all electrical panels (and similar electrical equipment) to maintain space clear above and below panel to structure and clearance of 3 feet directly in front of panel, except where indicated otherwise or required by NEC to be more. Such offsets are typically not shown on the drawings, but are required per this paragraph.
- G. Safety Protection: All piping and related items installed by this Contractor that present a safety hazard (i.e., items installed at/near head height, items projecting into maintenance access paths, etc.) shall be covered (at hazardous area) with 3/4" thick elastomeric insulation and 2" wide reflective red/white striped self-sticking safety tape.
- H. Equipment Access: Access to equipment is of utmost importance. Contractor shall apply extra attention to the laying out of pipe routings, and in coordinating all work. Poor access to equipment will not be accepted. Contractor shall note that in essentially all areas, piping routed in ceiling space needs to run in joist space, necessitating elbows/fittings/transitions at crosses with other trades, at structural beams, and at all connections to mains and branches. Dashed areas at HVAC units indicate equipment access areas. These (and all other) access areas shall be clear of

**NISQUALLY STATE PARK
NEW FULL SERVICE PARK – PHASE 2**

obstructions. The Division 22 contractor is responsible to coordinate and insure that all trades stay clear of access areas for any Division 22 furnished equipment.

- I. Insure that items to be furnished fit space available. Make necessary field measurements to ascertain space requirements including those for connections and furnish and install equipment of size and shape so final installation shall suit true intent and meaning of Contract Documents.

3.7 ADJUSTMENT AND CLEANING

- A. Properly lubricate equipment before Owner's acceptance.
- B. Clean exposed piping, equipment, and fixtures, remove debris from site. Repair damaged finishes and leave everything in working order.
- C. All work areas shall be left broom clean and free of debris. Sweep mechanical rooms at completion of work, and dispose of waste. Dispose of all existing waste in mechanical rooms in addition to waste generated by this work.

3.8 COMMISSIONING

- A. The Contractor has specific responsibilities relating to demonstrating the equipment and systems provided have been installed and function per the contract specifications. These responsibilities include, but are not limited to the following:
 - 1. Complete all equipment and system start-up and checkout procedures, and to insure the complete readiness of equipment and systems, prior to the start of the functional performance testing phase of the commissioning process.
 - 2. Functional test all plumbing systems in accordance with the Washington State Energy Code. Demonstrate system performance to the Engineer.
 - 3. Provide to the Owner a written commissioning process and the results of the functional performance testing.
- B. Owner shall not accept equipment and systems, and shall not make final payment, until all equipment and systems have been successfully commissioned and all specified requirements have been satisfied.

END OF SECTION

**NISQUALLY STATE PARK
NEW FULL SERVICE PARK – PHASE 2**

SECTION 220510 – EXCAVATION AND BACKFILL

PART 1 - GENERAL

1.1 WORK INCLUDED

- A. Excavation and Associated Grading.
- B. Trenching and Trench Protection.
- C. Backfilling and Compaction.
- D. Verification of Existing Utilities.
- E. Protection of Utilities.

1.2 QUALITY ASSURANCE

- A. Inspection of Job Conditions: Prior to starting work and during work, the installer shall examine the work by others, site and job conditions under which excavation, trenching, and backfilling for underground utilities work will be performed, and not proceed with work until unsatisfactory conditions have been corrected in a manner acceptable to the installer.
- B. Codes and Standards: Comply with requirements of the following codes and standards (Latest Edition) except as modified herein:
 - 1. International Building Code.
 - 2. Requirements of local County for all utility work, work in public right of way, and where specified.
 - 3. OSHA and WISHA regulations.

1.3 RESPONSIBILITY

- A. The Contractor is solely responsible for compliance with the requirements of the drawings and specifications local codes and standards, and the proper design, manufacture, delivery, construction coordination with work of other trades, protection and worker's safety. Contractor shall advise Design Consultant of any discrepancy in, or disagreement with the specifications and/or drawings prior to starting work and not proceed until issue is resolved. Only contractors who are fully experienced and entirely knowledgeable shall perform the work specified herein. Commencement of work shall indicate Contractor's acknowledgement of his expertise in this type of work. Any delay resulting from failure to comply with this procedure will not be basis for an extension of the completion date.

1.4 APPLICABLE PUBLICATIONS

**NISQUALLY STATE PARK
NEW FULL SERVICE PARK – PHASE 2**

- A. The publications listed below form a part of this specification to the extent referenced. The publications are referred to in the text by the basic designation only.
- B. American Society of Testing and Materials (ASTM) publications:
 - 1. D 422-63 Particle Size Analysis of Soils.
 - 2. D 423-66 Liquid Limit of Soils.
 - 3. D 424-59 Plastic Limit and Plasticity Index of soils.
 - 4. D 1557-78 Moisture Density Relations of Soils using a 10 lb (4.54kg) Rammer and 18 inch (457 mm) Drop.
 - 5. D 2167-66 Density of Soil In Place by the Rubber Balloon Method.
 - 6. D 2217-66 Wet preparation of Soil Samples for Particle Size Analysis and Determination of Soil Contents.
 - 7. D 2487-69 Classification of Soils for Engineering Purposes.
 - 8. D 2922-81 Test Methods for Density of Soil and Soil Aggregate In Place by Nuclear Methods (Shallow Depth).
 - 9. E 548-79 Generic Criteria for Use in the Evaluation of Testing and Inspection Agencies.

PART 2 - PRODUCTS

2.1 SATISFACTORY MATERIALS

- A. Materials classified as ASTM D2487, Unified Soil Classification System as SW, SP, GW, and GP are satisfactory for structural fill and for onsite use outside of structural fill areas. Materials classified as SP-SM, GP-GM, GM, GC and ML are also satisfactory for structural fill (excluding structural fill in building areas) provided that they contain moisture contents suitable for the intended use and are reasonably free of organic matter. Native material, not considered unsatisfactory as specified below, may comply. Except that no material shall have any dimension exceeding 2 inches.

2.2 UNSATISFACTORY MATERIALS

- A. Materials classified in ASTM D2487, Unified Soil Classification System as PT, OH, and OL are unsatisfactory. Unsatisfactory materials also include man-made fills, refuse and all materials containing excessive organic matter or having moisture contents which are not suitable for the intended use.

2.3 COHESIONLESS AND COHESIVE MATERIALS

- A. Cohesionless materials shall include materials classified in ASTM D2487 as GW, GP, SW, and SP. Cohesive materials include materials classified as GC, SC, ML CL, MH, and CH. Materials classified as GM and SM will be identified as cohesionless only when the fines are nonplastic. Liquid limit and plasticity index shall be determined in accordance with ASTM D423 using ASTM D2217, PROCEDURE B.

2.4 UNSTABLE MATERIAL

**NISQUALLY STATE PARK
NEW FULL SERVICE PARK – PHASE 2**

- A. Unstable material shall consist of material too wet to properly support the utility pipe, conduit, or appurtenance structure.

2.5 GRAVELLY SAND BORROW MATERIAL

- A. Gravelly sand borrow material to construct structural fills, provide backfill, or replace unsuitable soil in all building and paving areas shall meet the requirements of SW, SP, GW, and GP materials, except that the maximum percentage passing the No. 200 sieve shall not exceed 5% based on the soil fraction passing the U.S. No. 4 sieve, and not contain discrete particles greater than 6 inches in diameter.

2.6 DEGREE OF COMPACTION

- A. Degree of compaction shall be expressed as a percentage of the maximum density obtained by the test procedure presented in ASTM D1557, Method D. Minimum compaction requirements shall be as specified in PART 3.

2.7 DRAINAGE GRAVEL

- A. Shall be 3/4 inch washed gravel with no more than 2% passing 1/2 inch sieve opening.

2.8 BEDDING

- A. May be either (a) Minus 3/8 inch washed pea gravel, or (b) Gravelly Sand Borrow Material described above passing the 3/4 inch screen with a maximum of 5% passing the No. 200 sieve.

PART 3 - EXECUTION

3.1 EXCAVATION

- A. Excavation of every description and of whatever substances encountered shall be performed to allow the installation of all utilities at the lines and grades indicated; or where not indicated as required. During excavation, material satisfactory for backfilling shall be stockpiled in an orderly manner at a distance from the banks of the trench sufficient to avoid overloading and to prevent slides or cave-ins. Adequate drainage shall be provided for the stockpiles and surrounding areas by means of ditches, dikes, or other approved methods. The stockpiles shall also be protected from contamination with unsatisfactory excavated material or other material that may destroy the quality and fitness of the suitable stockpiled material.
- B. If the Contractor fails to protect the stockpiles and any material becomes unsatisfactory as a result, such material shall be removed and replaced with satisfactory on site or imported material from approved sources at no additional cost to the Owner.
- C. Excavated material not required or not satisfactory for backfill shall be removed from the site and shall be disposed of off site, at the Contractor's expense, at the Contractor's waste area. Any excess satisfactory excavated materials shall not be mixed with unsatisfactory materials.

**NISQUALLY STATE PARK
NEW FULL SERVICE PARK – PHASE 2**

Unsatisfactory materials shall not cover available suitable materials, or be disposed of in such a manner as to interfere with subsequent borrow operations.

- D. Grading shall be done as may be necessary to prevent surface water from flowing into the excavation, and any water accumulating therein shall be removed so that the stability of the bottom and sides of the excavation is maintained. Unauthorized over-excavation shall be backfilled at no additional cost to the Owner.

3.2 TRENCH EXCAVATION

- A. The trench shall be excavated as recommended by the manufacturer of the pipe to be installed. Where recommended trench widths are exceeded, redesign shall be performed by the Contractor using stronger pipe or special installation procedures. The cost of this redesign and the increased pipe or installation procedures shall be borne by the Contractor without additional cost to the Owner.
- B. Bottom Preparation: The bottoms of trenches shall be accurately graded to provide uniform bearing and support for the bottom quadrant of each section of the pipe and for bedding. Bell holes shall be excavated to the necessary size at each joint or coupling to eliminate point bearing. Stones of 3 inches or greater in any dimension, or as recommended by the pipe manufacturer, whichever is smaller, shall be removed to avoid point bearing.
- C. Removal of Unstable Material: Where unstable material is encountered in the bottom of the trench, such material shall be over-excavated 4" beyond the depth required for proper pipe bedding and replaced to the proper grade with select granular material as provided in paragraph. The Contractor is responsible for all costs associated with removing unstable material and replacing with suitable material. For bidding purposes the Contractor shall assume that 20% of all excavated material is unstable.
- D. Bedding: The bedding surface for the pipe shall provide a firm foundation of uniform density throughout the entire length of the pipe. The pipe shall be bedded carefully in a soil foundation accurately shaped and rounded to conform to the lowest one-fourth of the outside portion of circular pipe or to the lower curved portion of pipe arch for the entire length of pipe or arch. All the bedding shall be tamped into place. Bell holes and depressions for joints shall be only of such length, depth and width as required for properly making the particular type joint. Satisfactory materials may be used for bedding, except as noted in paragraph 3.6 of this section.

3.3 EXCAVATION FOR APPURTENANCES

- A. Excavation for vaults or similar structures shall be sufficient to leave at least 12 inches clear between the outer structure surfaces and the face of the excavation or support members. When concrete or masonry is to be placed in an excavated area, special care shall be taken not to disturb the bottom of the excavation. Excavation to the final grade level shall not be made until just before the concrete or masonry is to be placed.

**NISQUALLY STATE PARK
NEW FULL SERVICE PARK – PHASE 2**

3.4 JACKING, BORING AND TUNNELING

- A. Unless otherwise indicated, excavation shall be by open cut, except that sections of a trench may be jacked, bored, or tunneled if the pipe, cable or duct can be safely and properly installed and backfill can be properly tamped in such sections.

3.5 BACKFILLING

- A. Backfill material shall be compacted in 6" layers (except initial backfill which shall be 4") and as specified in Paragraph 3.7.
 - 1. Trench Backfill: Trenches shall be backfilled to finish grade. The trench shall be backfilled to above the top of pipe as shown on the drawings prior to performing the required pressure tests. The joints and couplings shall be left uncovered during the pressure test.
 - 2. Replacement of Unstable Material: Unstable material removed from the bottom of the trench or excavation shall be replaced with select granular material or gravel borrow placed in layers not exceeding 6 inches loose thickness.
 - 3. Bedding and Initial Backfill: Bedding shall be of the type and thickness shown on the drawings. Where not indicated, bedding shall consist of satisfactory materials, with no dimension exceeding 2" on any bedding material used. Initial backfill shall be in 4" lift.
 - 4. Backfill for Appurtenances: After the manhole, catch basin, inlet, or similar structure has been constructed and the concrete has been allowed to cure for the days specified, backfill shall be placed in such a manner that the structure will not be damaged by the shock of falling earth. The backfill material shall be deposited and compacted as specified for final backfill, and shall be placed in such a manner as to prevent eccentric loading and excessive stress on the structure. Compaction shall be as specified.

3.6 SPECIAL REQUIREMENTS

- A. Special requirements for both excavation and backfill relating to the specific utilities are as follows:
 - 1. Fire Lines: Trenches shall be of a depth to provide a minimum cover of 3.5 feet (or deeper if required by local authority) from the existing ground surface, or from the indicated finished grade, whichever is lower, to the top of the pipe. Bedding shall use satisfactory materials as specified.
 - 2. Domestic Water Lines: Trenches shall be of a depth to provide a minimum cover of 3.5 feet (or deeper if required by local authority) from the existing ground surface, or from the indicated finished grade, whichever is lower, to the top of the pipe. Except that branch lines serving individual fixtures within building footprint shall have minimum of 1.0 foot cover. Bedding shall use satisfactory materials as specified.

3.7 COMPACTION

- A. Each layer of fill, or the excavated subgrade, shall be compacted to at least 95 percent, per ASTM D1557, of laboratory maximum density. Compaction shall be accomplished by approved tamping rollers, pneumatic-tired rollers, three-wheel power rollers, or other approved compaction

**NISQUALLY STATE PARK
NEW FULL SERVICE PARK – PHASE 2**

equipment. Areas requiring structural fill to four feet below footings not accomplished under the previous contract, shall be compacted to 90% of maximum density, per ASTM D1557.

3.8 PROTECTION

- A. Newly graded excavated or bedded areas shall be protected from traffic and from erosion, and any settlement or washing away that may occur from any cause, prior to acceptance, shall be repaired and grades reestablished to the required elevations and slopes.
- B. Verify location of existing utilities prior to beginning work. Utilize Owner as-builts, field electronic detection equipment, visual site surveys, and careful exploratory digging at key locations. Protect all existing utilities from damage.

END OF SECTION

**NISQUALLY STATE PARK
NEW FULL SERVICE PARK – PHASE 2**

SECTION 220519 – PIPING SPECIALTIES

PART 1 - GENERAL

1.1 WORK INCLUDED

- A. Thermometers
- B. Pressure Gauges
- C. Strainers
- D. Unions
- E. Flexible Connectors

PART 2 - PRODUCTS

2.1 APPROVED MANUFACTURERS

- A. Flexible Connectors: Flexonics, Metraflex, Resistoflex, Universal

2.2 THERMOMETERS

- A. Adjustable angle type, with brass stem, separable brass sockets, 7-inch scale, aluminum case, red reading mercury, white face with black numerals, and markings in degrees F. Provide sockets with extension necks where installed on insulated piping.
- B. Thermometer Temperature Ranges:

Measuring	Range Degrees F	Increments Degrees F
Domestic Cold Water	0 - 100	1
Domestic Hot Water	30 - 180	2

2.3 PRESSURE GAUGES

- A. Pressure Gauges: 4-1/2-inch dial (except natural gas gauges which shall have 2-1/2 inch dial), stem mounting, aluminum or stainless steel case, white face with black numerals, phosphor bronze bourdon tube, 1/4-inch NPT bottom connection. Provide a shut-off cock for all gauges, coil siphon for all steam gauges, and snubber on all liquid line gauges.
- B. Pressure Gauge Ranges:

Measuring	Range PSIG	Intervals PSIG	Inter-Graduations
Heating Hot Water	0 - 200	20	2
Chilled Water	0 - 120	20	2

**NISQUALLY STATE PARK
NEW FULL SERVICE PARK – PHASE 2**

2.4 STRAINERS

- A. Water Strainers: "Y" type, same size as the pipe in which they are installed, with cast iron or semi-steel bodies rated for 125 psi working pressure, and with removable cover and sediment basket. Basket screen shall be stainless steel or monel, with a net free area of at least 3 times that of the entering pipe. Provide with blowdown valve where shown on the drawings.

2.5 UNIONS

- A. Dielectric Unions: Rated at 250 psi at 180 deg. F., conforming to ANSI B16.39. Type and size to match piping.
- B. Unions on Copper Pipe:
 - 1. In 2-Inch Pipe and Smaller: Wrought copper solder joint copper to copper union.
 - 2. In 2-1/2-Inch Pipe and Larger: Brass flange unions.

2.6 FLEXIBLE CONNECTORS

- A. Double Bellows Type: Steel Flanges, Nylon reinforced neoprene body, Kinetics model KinFlex or approved.

PART 3 - EXECUTION

3.1 INSTALLATION

- A. Unions: Install unions in pipe connections to control valves, coils, regulators, reducers, all equipment, and where it may be necessary to disconnect the equipment or piping for repairs or maintenance; and as indicated.
- B. Dielectric Unions: Install dielectric unions at all connections between dissimilar piping materials.

END OF SECTION

**NISQUALLY STATE PARK
NEW FULL SERVICE PARK – PHASE 2**

SECTION 220520 – PIPE AND PIPE FITTINGS

PART 1 - GENERAL

1.1 WORK INCLUDED

- A. Pipe.
- B. Pipe Fittings.
- C. Pipe Joining and Connections.

1.2 SUBMITTALS

- A. Shall comply with Section 220500 General Plumbing Requirements.
- B. Product submittals are required for all pipe and pipe fittings to be used on this project.

1.3 GENERAL REQUIREMENTS

- A. Application: See each individual system specification sections for call-out of piping materials to be used for that system.

1.4 REFERENCES

- A. ANSI B16.4: Cast Iron Threaded Fittings
- B. ANSI B16.3: Malleable Iron Threaded Fittings
- C. ANSI B16.5: American 150, 300, 400, 600, 900, 1,500, and 2,500 Pound Steel Flange Standards.
- D. ANSI/ASTM B88: Seamless Copper Water Tube.
- E. ANSI/ASTM B32: Solder Metal.
- F. ANSI B16.22: Wrought Copper and Bronze Solder Joint Pressure Fittings.
- G. ANSI B16.18: Cast Bronze Solder Joint Pressure Fittings.
- H. ANSI B16.24: Cast Copper and Bronze Flange Fittings.
- I. CISPI 301: Cast Iron Soil Pipe and Fittings for Hubless Cast Iron Sanitary System.
- J. ASTM 564: Rubber Gaskets for Cast Iron Soil Pipe and Fittings.
- K. CISPI 310: Cast Iron Soil Pipe Couplings for Hubless Cast.

**NISQUALLY STATE PARK
NEW FULL SERVICE PARK – PHASE 2**

- L. ANSI/ASTM D3212: Joints for Drain and Sewer Plastic Pipes Using Flexible Elastomeric Seals.
- M. ANSI/ASTM F477: Elastomeric Seals (Gaskets) for Joining Plastic Pipe.
- N. ANSI/ASTM D1785: PVC Plastic Pipe
- O. ANSI/ASTM D2466: PVC Plastic Pipe Fittings
- P. ANSI/ASTM D2672: Joints for PVC Pipe Using Solvent Cement
- Q. ANSI/ASTM D2661: ABS Plastic Pipe
- R. ANSI/ASTM D2235: Joints for ABS Pipe Using Solvent Cement

PART 2 - PRODUCTS

2.1 ACCEPTABLE MANUFACTURERS

- A. Products shall comply with Section 220500, Acceptable Manufacturers.
- B. Steel Pipe and Fittings: U.S. Steel, Bethlehem, Walworth, Flagg, Grinnell, Felker.
- C. Copper Pipe and Fittings: Mueller, Nibco, Flagg, Elkhart.
- D. Cast Iron Pipe: U.S. Steel, Tyler, U.S. Pipe & Foundry
- E. Ductile Iron Pipe and Fittings: Pacific States, Union Foundry
- F. Plastic Pipe and Fittings: Tyler, Chemtrol, Western Plastics, Spears, GPK.
- G. Miscellaneous Fittings/Materials: As called out in individual specifications.

2.2 COPPER PIPE AND FITTINGS

- A. Pipe: Seamless copper tubing, type K, L, or M as indicated, per ANSI/ASTM B88.
- B. Fittings: Soldered joints with 95.5 tin antimony solder per ANSI/ASTM B32 or "Silvabrite 100" (95.5 tin/4 copper/0.5 silver) solder. Solder shall be lead-free. Wrought copper fittings per ANSI B16.22, cast bronze fittings per ANSI B16.18, cast flange fittings 150 lb per ANSI B16.24. Underground joints shall be brazed, with BCuP 4, BCuP 5, or BAg 1 filler metals (per American Welding Society Standards).
- C. Refrigerant Pipe and Fittings: Piping shall be ACR Type L copper tubing, with silver brazed joints using filler metals per American Welding Society Standards, and wrought copper fittings.

2.3 NO HUB CAST IRON PIPE AND FITTINGS:

- A. Pipe: Service weight no hub cast iron pipe per CISPI 301.

**NISQUALLY STATE PARK
NEW FULL SERVICE PARK – PHASE 2**

- B. Fittings: Mechanical joints, stainless steel couplings with neoprene gaskets per ASTM C564 and CISPI 310. Below grade couplings shall be cast iron, conforming to CISP 301-78, and shall be MG Coupling Co. or approved.

2.4 CAST IRON SOIL PIPE AND FITTINGS:

- A. Pipe: Service weight cast iron per ANSI/ASTM A74 coated with tar pitch.
- B. Fittings: Bell and spigot joints, with neoprene gaskets per ASTM C564, and CISP-HSN.

2.5 DUCTILE IRON PIPE AND FITTINGS:

- A. Pipe: Ductile iron pipe shall conform to AWWA C151 and shall be Thickness Class 50 minimum. Pipe shall have cement mortar lining conforming to AWWA C104/ANSI A21.4; standard thickness.
- B. Fittings: Fittings shall conform to AWWA C110; fittings with push-on joint ends shall conform to the same requirements as fittings with mechanical-joint ends, except that the bell design shall be modified, as approved, for push-on joint. Fittings shall have pressure rating at least equivalent to that of the pipe. Fittings shall have cement-mortar lining conforming to AWWA C104/A21.4, standard thickness.

2.6 COPPER DWV PIPE AND FITTINGS

- A. Pipe: Copper drainage tube (DWV), per ASTM B306.
- B. Fittings: Wrought copper and wrought copper alloy solder-joint drainage fittings, per ANSI B16.29; or cast copper alloy solder joint drainage fittings, DWV, per ANSI B16.23.

PART 3 - EXECUTION

3.1 PIPE INSTALLATION – GENERAL

- A. All piping in finished areas shall be installed concealed unless specifically noted otherwise.
- B. Install piping at such heights and in such a manner so as not to obstruct any portion of windows, doorways, or passageways.
- C. Coordinate installation of piping with all trades which are affected by installation to avoid conflicts.
- D. Offset or reroute piping as required to clear any interferences which may occur.
- E. Consult all drawings for location of pipe spaces, ducts, electrical equipment, ceiling heights, door openings, window openings, and other details and report discrepancies or possible conflicts to Architect/Engineer before installing pipe.

**NISQUALLY STATE PARK
NEW FULL SERVICE PARK – PHASE 2**

- F. Allow sufficient clearances for installation of pipe insulation in thickness specified. If interferences occur, reroute piping to accommodate insulation.
- G. Pitch all piping and provide drain valves so that all piping and equipment can be drained.
- H. Provide escutcheons where pipe passes through walls, floors, or ceilings.
- I. Install all exposed piping parallel to the closest wall and in a neat, workmanlike manner.
- J. Do not run any piping above electrical panels (and similar electrical equipment). Provide offsets around such panels as necessary.

3.2 PIPE JOINING

- A. General: Prior to the joining of any section of pipe to a pipe run, the section shall be thoroughly cleaned inside and out, and the ends shall be reamed to remove any cutting burrs.
- B. Threaded Connections: Cut piping carefully, ream, thread and work into place without springing. Use teflon tape or lead and graphite lubricant- on male threads only.
- C. Caulked Connections: Cast iron pipe shall be made with picked oakum and at least 1 1/2 inches of molten lead or joined with neoprene gaskets in accordance with manufacturer's assembly instructions.
- D. Hubless Connections: Made with hubless type coupling assemblies in accordance with manufacturer's recommendations
- E. Soldered Connections: Polish contact surfaces of fittings and pipes with emery cloth before fluxing male and female surfaces of joints. Steel wool and sandpaper not permitted for polishing.
- F. Unions: Install unions in pipe connections to valves, coils, and any other equipment where it may be necessary to disconnect the equipment or piping for repairs or maintenance; and as indicated. Where flanged connections occur at equipment additional unions are not required unless indicated otherwise.
- G. Insulating Unions: Install dielectric insulating unions or insulating type flexible connectors between all connections of copper piping and steel piping or steel equipment. Where flanged connections occur use insulating type flanges.

END OF SECTION

**NISQUALLY STATE PARK
NEW FULL SERVICE PARK – PHASE 2**

SECTION 220529 – PIPING HANGERS AND SUPPORTS

PART 1 - GENERAL

1.1 WORK INCLUDED

- A. Pipe Hangers
- B. Equipment Hangers

1.2 QUALITY ASSURANCE

- A. Pipe Hanger Standards: (MSS) Manufacturers Standardization Society Standards SP-58-1975, SP-89-1978, and SP-69-1976.
- B. All methods, materials and workmanship shall conform to the International Building Code (IBC) and International Mechanical Code (IMC), as amended and adopted by the authority having jurisdiction.

1.3 SUBMITTALS

- A. Submittals shall comply with Section 220500 General Plumbing Requirements.
- B. Submit product data. Indicate where such items are to be used.
- C. Shop drawings are required for all equipment supports and fabricated supports or assemblies.

PART 2 - PRODUCTS

2.1 ACCEPTABLE MANUFACTURERS

- A. Hangers and Supports: Elcen, Grinnell, B-Line Systems, Unistrut, Michigan, Tolco.
- B. Anchors: Rawplug, Phillips, Hilti, Michigan.

2.2 GENERAL HANGERS AND SUPPORTS

- A. Hanger Rods: Threaded hot rolled steel, electro-galvanized or cadmium plated. Hanger rods shall be sized so that the total load (including pipe or duct, insulation, hangers, and fluid) does not exceed the following:

Nominal Rod Diameter	Maximum Load
1/4 Inch	240 Pounds
5/16 Inch	440 Pounds
3/8 Inch	610 Pounds

**NISQUALLY STATE PARK
NEW FULL SERVICE PARK – PHASE 2**

1/2 Inch	1130 Pounds
----------	-------------

- B. Hanger Straps: Galvanized steel. Straps shall be sized so that the total load does not exceed the following:

Strap Size	Maximum Load
1" x 22 Gauge	230 Pounds
1" x 20 Gauge	290 Pounds
1" x 18 Gauge	380 Pounds
1" x 16 Gauge	630 Pounds

- C. Beam Attachments: Shall be of the following type:

MSS Type	Elcen Figure No.	Grinnell Figure No.
21	33, 34	131
22	67	66
23	29A	87
28	95	292, 228
30	95	229

- D. Steel: Structural steel per ASTM A36.

- E. Wood: Shall be fire treated.

2.3 PIPE HANGERS AND SUPPORTS

- A. All hangers used directly on copper pipe shall be copper plated or have a factory applied 1/16-inch thick (minimum) plastic coating on all contact surfaces.

- B. All other hangers, supports, and hardware shall be cadmium plated or galvanized.

- C. Pipe Hangers and Supports: Shall be of the following type (numbers are 'MSS'):

Maximum System Temperature	Insulated Pipe Type
120 to 450 Degrees	1, 3, 7, 9, 10, 41, 42, 43, 44, 45, 46, E
60 to 120 Degrees	1, 3, 7, 9, 10
33 to 59 Degrees	1, 3, 5, 7, 9, 10, 41, 42, 43, 44, 45, 46, E

- D. Vertical Pipe Supports: MSS Type 8 riser clamp (elcen Fig. 39 and 339; Grinnell Fig. 261 and 261C).

- E. Trapeze Hangers: Shall be constructed of carbon steel angles, channels or other structural shapes with flat surface for point of support. Trapeze hangers shall be supported with hanger rods suspended from concrete inserts or approved structural clips. Provide a steel washer plate (Elcen Fig. 84 or equal) where hanger rod nuts bear on trapeze hanger.

- F. Insulated Pipe Supports:

1. Insulation material at pipe support shall consist of expanded perlite insert with flame resistant jacket of nylon reinforced kraft paper bonded to aluminum foil cover on insulation, with sheet metal shield. Expanded perlite shall have no more than 5% deformation at 100 psi and a thermal conductivity no more than 0.32 Btu/hr./sq. ft./degree F/1-inch thick.

**NISQUALLY STATE PARK
NEW FULL SERVICE PARK – PHASE 2**

2. Expanded perlite insert shall be same thickness as adjoining pipe insulation, sized to match pipe used on.
3. Minimum insulation, shield lengths, and shield gauge:

Normal Pipe Diameter In Inches	Insulation Length In Inches	Shield Length In Inches	Minimum Shield Gauge
1/2 to 2	6	3	20
2-1/2 to 3-1/2	6	4	18
4 to 5	9	6	18
6 to 10	9	6	16

4. Manufacturer: Michigan Hanger Company, Model Nos. 1031 and 4031.

PART 3 - EXECUTION

3.1 INSTALLATION – GENERAL

- A. Provide all necessary bolts, nuts, washers, turnbuckles, rod connectors and any other miscellaneous accessories required for the support and anchoring of all pipes, ducts, and mechanical equipment.
- B. Install steel or wood backing in walls (anchored to studs) as required to provide support for items hung from walls. Backing shall be of the same material as the studs or structure they are attached to.
- C. All welded steel support assemblies shall have a power wire brush and primer paint finish.
- D. Attach to building structure as shown on drawings.
- E. Maximum spans between piping supports may be significantly less than the maximum spans allowed herein due to structural limitations of allowable loads on hangers. The most restrictive criteria governs. Reference structural drawings.

3.2 INSTALLATION OF PIPE HANGERS AND SUPPORTS

- A. Pipe which is not run underground shall be adequately anchored to the structure to prevent sagging and to keep pipe in alignment.
- B. All pipe supports shall be provided with a means of adjustment for the aligning and leveling of the pipe after installation.
- C. Installation and sizing of pipe supports and accessories shall be in accordance with the manufacturer’s recommendations and standard MSS SP-89 and MSS SP-69, UPC, and UMC.
- D. Provide supports at each change in direction of piping.
- E. Where mechanically coupled piping is used, a hanger shall be placed within 2 feet on each side of couplings, with hanger spacing in no case to exceed the following:

**NISQUALLY STATE PARK
NEW FULL SERVICE PARK – PHASE 2**

Normal Pipe Diameter	Maximum Span Mechanically Coupled Piping
3/4 to 1 Inch	7 Feet
1-1/4 to 1-1/2 Inch	7 Feet
2 Inches	10 Feet
2-1/2 Inches	10 Feet
3 Inches and Larger	12 Feet

NOTE: Manufacturer's support instructions shall be used where it is more restrictive than the above. Above is for rigid coupled piping systems. Follow manufacturer's requirements for flexible piping systems, except that in no case is spacing to be less than the above.

F. Copper Tubing: Maximum spacing between supports:

Nominal Tubing Diameter	Maximum Span Copper
1/2 to 1 Inch	5 Feet
1-1/4 to 1-1/2 Inch	6 Feet
2 to 2-1/2 Inch	8 Feet
3 Inches and Larger	10 Feet

- G. Three or more pipes running parallel may be supported on trapeze hangers provided the slopes of such pipes allow use of common trapeze. Where trapeze width exceeds 24 inches, provide three (3) hanger rod supports.
- H. Provide additional supports at concentrated loads (such as valves, in-line pumps, etc.) on each side of the load. Such supports are in addition to the ones otherwise required.
- I. Vertical Piping Supports: Support piping at each floor line with pipe clamps and at intermediate points as required to prevent excessive pipe movement and so as to comply with the maximum spacings cited above. Support all pipe stacks at their bases with a concrete pier or suitable hanger. For vertical pipe drops which occur away from a wall or similar anchoring surface, provide angled bracing from nearest structure to provide rigid anchoring of pipe drop.
- J. Pre-Insulated Pipe Supports: Protect all insulated pipe at point of support with pre-insulated pipe supports. Such supports shall be in place at time of installing pipe.

END OF SECTION

**NISQUALLY STATE PARK
NEW FULL SERVICE PARK – PHASE 2**

SECTION 220530 – PIPING SLEEVES AND SEALS

PART 1 - GENERAL

1.1 WORK INCLUDED

- A. Pipe Sleeves
- B. Seals

1.2 REFERENCES

- A. ASTM E814: Fire Tests of Through-Penetration Fire Stops
- B. UL 1479: Through-Penetration Fire Stop Systems.

PART 2 - PRODUCTS

2.1 ACCEPTABLE MANUFACTURERS

- A. Products shall comply with Section 220500 General Plumbing Requirements.
- B. Fire Seals: 3M, Down Corning, General Electric, Rectorseal.

2.2 PIPE SLEEVES

- A. Size: Inside diameter of pipe sleeves shall be at least 1/2-inch larger than the outside diameter of the pipe or pipe covering, so as to allow free movement of piping.
- B. Ends: Sleeve ends shall be cut flush with finished surfaces, except in rooms having floor drains where sleeves shall be extended 3/4-inch above finished floor.
- C. Material - Structural: Sleeves through structural elements shall be fabricated from Schedule 40 steel pipe.
- D. Material - Non-structural: Sleeves through non-structural elements shall be fabricated from 18 gauge galvanized sheet metal or 24 gauge spiral duct.

2.3 SEALS

- A. Seals at exterior of building: Provide a sleeve through exterior walls sealed to the wall system per architectural plans. Core drilled penetrations in concrete do not require a sleeve. Provide modular mechanical seal between the sleeve and penetrating pipe. Eaton Link-Seal or approved.

**NISQUALLY STATE PARK
NEW FULL SERVICE PARK – PHASE 2**

- B. Seals in other areas: Packed fiberglass or wool insulation, where no weatherproofing or adhesive properties are required; otherwise, sealants shall be silicone type, as specified in applicable Division 7 Specification Section.

PART 3 - EXECUTION

3.1 INSTALLATION OF PIPE SLEEVES

- A. Provide pipe sleeves for all piping passing through walls, floors, partitions, roofs, foundations, footings, grade beams, and similar elements, except that sleeves are not required for penetrations through existing single solid elements, having no voids, at the location where the piping passes through the solid elements (e.g., solid wood stud, core drilled solid concrete, etc.). Where a sleeve is required, such sleeve shall continue all the way through any solid items within that element however.
- B. Set sleeves plumb or level (or sloped as required for drainage pipe) in proper position, tightly fitted into the work.
- C. Fill openings around outside of pipe sleeve with same material as surrounding construction, or with material of equivalent fire and smoke rating.
- D. Seal around all pipes inside of pipe sleeve.
- E. Insulation shall run continuous through sleeves in non-fire rated elements. Insulation shall not run continuous through sleeves in fire rated elements unless the fire sealant system used is UL accepted for use with insulated pipes.

3.2 INSTALLATION OF SEALS

- A. Provide seals around all piping and ducts passing through walls, floors, roofs, foundations, footings, grade beams, partitions, and similar elements.
- B. Pipe penetrations through the building envelope shall be sealed water tight.

END OF SECTION

**NISQUALLY STATE PARK
NEW FULL SERVICE PARK – PHASE 2**

SECTION 220548 – PIPING VIBRATION AND SEISMIC CONTROL

PART 1 - GENERAL

1.1 WORK INCLUDED

- A. Vibration Isolators
- B. Seismic Restraints

PART 2 - PRODUCTS

2.1 NEOPRENE ISOLATORS

- A. Suspension Isolators: Shall be double deflection neoprene type, with isolator encased in open steel bracket and minimum 3/8-inch deflection. Hanger rod shall be isolated from steel bracket with neoprene grommets. Mason Series HD, Amber Booth "BRD" or approved.

2.2 SPRING ISOLATORS

- A. General: The load carried by each isolator shall be carefully calculated and isolators selected so that the static deflection will be the same and the supported equipment will remain level. Isolators shall be so designed that the ends of the springs will remain parallel during and after deflection to operating height. At operating height, springs shall have additional travel to complete (solid) compression equal to at least 50 percent of the operating deflection. Suspension isolator springs shall have a static deflection (as shown on drawings) not less than 1-1/2", except that for units with components rotating at 1000 rpm and less, the static deflection shall be not less than 2 inches. Floor isolator springs shall have deflection of not less than 1 inch. All isolators shall provide at least 96% isolation efficiency. Note: Deflections other than these may be used where circumstances warrant and more optimum isolation results can be achieved.
- B. Suspension Type Spring Isolators: Shall consist of a rigid steel frame, a stable steel spring in the bottom part of the frame, and double deflection neoprene isolating pad at the top of the frame. Where supporting rods pass through the frame, a clearance of not less than on half rod diameter shall be provided all around the rod. Mason Series DNHS, Amber Booth "BSSR" or approved.

2.3 SEISMIC RESTRAINTS

- A. Materials: Steel shall be per STM A36; hangers and other devices shall be as shown in SMACNA Seismic Restraint Manual Guidelines for Mechanical Systems latest edition. Sheet metal used for bracing shall be no less than 16 gauge. Cable bracing may be used provided that opposed acting cables are provided on the items being braced to provide bracing equal to that provided by rigid angle bracing.

**NISQUALLY STATE PARK
NEW FULL SERVICE PARK – PHASE 2**

PART 3 - EXECUTION

3.1 INSTALLATION

A. Vibration Isolation:

1. Motorized equipment shall be suspended from spring vibration isolators either integral or external to the equipment.
2. Unless otherwise indicated, resilient mounts for motorized equipment shall be of the type and size to provide maximum ten percent transmissibility. Use unhoused, free-standing stable steel springs which are preferred over housed spring assemblies. The horizontal stiffness of the spring shall be approximately equal to its vertical stiffness. The Spring deflection shall be selected based on the equipment power range (HP), speed range (RPM), and static deflection of the supporting structural floor. For large equipment such as fans the steel spring static deflection of the supporting structural floor. It is a specific recommendation that whenever a steel spring is used, two pads of ribbed waffle-pattern neoprene be used in series with the spring.
3. The design of vibration dampening shall consider lateral load as well as vertical load and be suitably snubbed against earthquake forces.
4. A list of isolators accompanied by certified transmissibility ratings for the required duty shall be submitted for each item of equipment.
5. Unless noted otherwise, all vibration isolating equipment shall be of the same make and shall be submitted as one group.
6. Special equipment, such as compressors shall be selected on an individual basis.

3.2 SEISMIC CONTROL

- A. Provide earthquake snubbers for all equipment that is supported on spring isolators and weighing over 300 lbs. including base. Provide minimum of four snubbers for equipment weighing less than 2,000 lbs., and eight snubbers for heavier equipment.
- B. Pipes of all sizes that are suspended on hangers that are longer than 12” shall be have a transverse brace every 40 ft and a longitudinal brace every 80 ft.

END OF SECTION

**NISQUALLY STATE PARK
NEW FULL SERVICE PARK – PHASE 2**

SECTION 220700 – PIPING INSULATION

PART 1 - GENERAL

1.1 WORK INCLUDED

- A. Pipe Insulation.
- B. Equipment and Specialties Insulation.

1.2 DEFINITIONS

- A. "Run-out" means "piping not more than 12 feet long that runs to an individual fixture or unit."
- B. "Conditioned Areas" means "areas that are directly and intentionally supplied by heated or cooled air".

1.3 QUALITY ASSURANCE

- A. All insulation shall have a fire hazard rating not to exceed 25 for flame spread and 50 for smoke development, as tested by ASTM E 84, NFPA 255, and UL 723.

1.4 SUBMITTALS

- A. All submittals shall comply with Section 220500 General Plumbing Requirements.
- B. Provide product data on all insulation materials to be used. Indicate thicknesses to be used.

1.5 GENERAL REQUIREMENTS

- A. Code Compliance: Contractor shall insulate all systems with the materials and thicknesses as specified herein, but in no case shall the insulation be less than that required by the Washington State Energy Code (latest edition and amendments) or Energy Code enforced by the authority having jurisdiction. Contractor shall, in addition to insulating those systems/items specified herein, provide insulation where required by Code.
- B. Insulation at Hangers: Insulation shall be continuous through hangers on all insulated systems (except ductwork.) Inserts at hangers are specified and are considered as part of the hanger and support system. Inserts are required to be installed at the time of pipe installation and are intended to be installed by the Contractor installing the pine hangers/supports.

PART 2 - PRODUCTS

**NISQUALLY STATE PARK
NEW FULL SERVICE PARK – PHASE 2**

2.1 ACCEPTABLE MANUFACTURERS

- A. Products shall comply with Section 220500 General Plumbing Requirements.
- B. Insulation: Manville, Armstrong, Owens Corning, CSG, Knauf, Rubatex, Pittsburgh Corning, Imcoa, Halstead.
- C. Accessories: Same as for insulation and Duro Dyne, Gustin Bacon, Childers, RPR, Tee Cee, J. P. Stevens, Buckaroos, Johnson.

2.2 PIPE INSULATION

- A. Fiberglass Insulation: Rigid fiberglass insulation, thermal conductivity shall not exceed 0.24 Btu inch/hr sq. ft. degrees F. at 75 degrees F with jacket consisting of high density white kraft bonded to aluminum foil, with pressure sensitive closure system, integral vapor barrier with 0.02 perm rating.
- B. Elastomeric Insulation: Density not less than 5 lbs per cubic foot and thermal conductivity not greater than 0.27 Btu inch/hr ft degrees F. Armstrong "Armaflex" or equal.
- C. Foamglas Insulation: Glass cell insulation, Pittsburgh Corning "Foamglas," with thermal conductivity no less than 0.35 Btu-in/hr-sq. ft.-degrees F at 75 degrees F, compressive strength of 100 psi, and water-vapor permeability of 0.00 perm-inch as tested per ASTM and "pittwrap" water-proof membrane.
- D. Pipe Fittings (except unions and expansion couplings): Shall be covered using any one of the following methods of the Contractor's choice:
 - 1. Prefabricated segments of pipe insulation of same materials and thickness as the adjoining pipe insulation, formed to match pipe fitting.
 - 2. Pre cut fiberglass insulation and pre-molded PVC covers suitable for the pipe size and insulation thickness encountered. PVC cover shall be equal to Manville "Zeston."
 - 3. Insulating plastic cement brought up the full height of the adjacent covering.
- E. Metal Jacket: Aluminum roll jacketing, with smooth surface, manufactured from 1100, 3003, 3105 or 5005 aluminum alloy conforming to ASTM B-209. Shall be minimum 0.016 inches thick, with an integrally bonded interior moisture barrier over the entire surface in contact with the insulation.
- F. P-traps and HW/CW Lines on Handicap Lavatories: Prefabricated insulation specially designed for p-trap application, with white elastomeric insulation, white high gloss PVC cover, and snap together closure. Provide section for insulating HW stop, CW stop, and leads of same material. TRU BRO "LAV GUARD" or equal.
- G. Insulation Thickness and Types:
 - 1. Domestic Hot Water:

**NISQUALLY STATE PARK
NEW FULL SERVICE PARK – PHASE 2**

a. Aboveground:

Pipe Size	Fiberglass Insulation Thickness
Run outs Up to 2 Inches	0.5 Inch
1 Inch and Less	1.0 Inch
1.5 Inches to 2 Inches	1.5 Inch
2.5 Inches to 4 Inches	2.0 Inch

2. Domestic Cold Water: 1/2 inch thick fiberglass insulation.
3. Refrigerant Suction Piping:
 - a. 1 inch thick elastomeric insulation for pipe sizes 1 inch and less; 1.5 inch thick elastomeric for larger pipe sizes.
4. Condensate Drain Piping (within the building): 1/2 inch thick fiberglass or elastomeric insulation.
5. Outdoor Piping: Piping exposed to outside air shall have insulation thickness increased by 0.5 inch from that indicated above. Elastomeric insulation may be used in lieu of fiberglass, provided the insulation is manufacturer approved for applications proposed.
6. Alternative Insulation Thickness: Insulation thickness indicated is based on the thermal conductivities specified. Contractor at his option may use other insulation thicknesses for insulation with different thermal conductivities provided that the overall heat transfer coefficient is the same as if the specified insulation had been used. Submit calculations showing insulation equivalency for approval.

2.3 EQUIPMENT AND SPECIALTIES INSULATION

- A. Equipment: Insulation shall be same material as that specified for the piping system the equipment is installed in. Insulation thickness shall be 1.5 inches.
- B. Valves: All valves installed in insulated piping systems shall be insulated. Insulation material and thickness shall be same as that specified for the pipe system the valve is installed in. Insulation shall be removable type on all control valves.
- C. Removable Insulation: Shall provide thermal insulating properties equivalent to that which is provided for piping system. Shall consist of 0.25-inch J. P. Stevens "Insulbatte" with glass cloth jacket, 4.0-inch Owens-Corning thermal insulating wool, Type II, fastened with No. 304 stainless steel hooks tied with 0.040-inch soft solid annealed copper wire. Where metal jacketing is required, provide with removable enclosures, of same material as metal jacketing, configured to suit items covered.

PART 3 - EXECUTION

3.1 GENERAL

- A. Equipment and Floor Protection: Cover existing equipment and finished floors to protect such items from insulation fiber and dust. Keep all such existing areas in a "broom clean" condition at the end of each day. Take precautions in these areas to prevent glass fiber and insulation dust from entering existing ventilating systems.

**NISQUALLY STATE PARK
NEW FULL SERVICE PARK – PHASE 2**

- B. Glass Fiber Insulation:
 - 1. Finish all insulation ends, no raw edges allowed.
 - 2. Joints: Tightly butt adjacent insulation sections together without any voids. Provide overlap of jacket material over all circumferential joints.
- C. Insulation Thickness: See "Part 2 - Products" for insulation thicknesses.
- D. Items To Be Insulated: Provide insulation on all piping, and all items installed in the piping systems, all energy conveying, all energy storage, and all energy consuming devices specified as part of Division 22, except where such insulation has been specifically excluded.
- E. Items Excluded From Being Insulated:
 - 1. Electric motors.
 - 2. Factory insulated water heaters (except for base).
 - 3. Fire sprinkler piping.
 - 4. Stops and risers at plumbing fixtures (Except ADA Lavatories).

3.2 PIPE INSULATION INSTALLATION

- A. All ends shall be firmly butted together and secured with butt strips of a minimum 3 inch wide. On hot piping, all jacket laps and butt strips shall be secured with outward clinch staples at 4 inch spacing, or by use of a suitable lap adhesive.
- B. All piping shall be insulated except where specifically excluded.
- C. Elastomeric Pipe Insulation: Shall be completely sealed to provide a vapor proof barrier.
- D. Pipe Hangers: Provide insulation tight up to pre insulated pipe supports at pipe hangers.
- E. Pipe Sleeves: For insulated pipe, do not run insulation through sleeve, except where fire sealant system used is UL approved for use with insulated pipes, then install insulation in full sized thickness completely through the pipe sleeve.
- F. No pipe covering materials shall be applied until the pipe runs to be covered have been tested by the Contractor and reviewed by the Architect Engineer, and no covered sections of pipe shall be buried or concealed in the structure until said insulation and covering work has been reviewed.
- G. Handicap Lavatories: Insulate P-trap and HW supplies below lavatory where exposed.
- H. Items in piping that require access (i.e. flow measurement devices) shall have removable insulation provided.
- I. Provide metal jacket over piping insulation for all outside exposed piping.

3.3 EQUIPMENT AND SPECIALTIES INSTALLATION

**NISQUALLY STATE PARK
NEW FULL SERVICE PARK – PHASE 2**

- A. All equipment where access is required shall have insulation installed so that it can be easily removed and reinstalled without requiring new insulation. Items requiring such removable insulation include, but are not limited to, the following:
1. Control Valves.
 2. Strainers.
 3. Balancing Devices.
 4. Pressure/Temperature/Flow Measuring Devices.
- B. Specialties Requiring Insulation: All items connected in an insulated piping system shall be insulated, except the following:
1. Factory Insulated Items.
 2. Water Meters.
 3. Hose Bibbs.
 4. Relief Valves.

END OF SECTION

**NISQUALLY STATE PARK
NEW FULL SERVICE PARK – PHASE 2**

SECTION 221100 – DOMESTIC WATER PIPING SYSTEM

PART 1 - GENERAL

1.1 WORK INCLUDED

- A. Domestic Water Piping.
- B. Valves.
- C. Water Hammer Arrestors and Air Chambers.
- D. Trap Primers.
- E. Backflow Preventers.
- F. Water Service Connections.
- G. Testing and Inspection.
- H. Sterilization.

1.2 SUBMITTALS

- A. Submittals shall comply with Section 220500 General Plumbing Requirements.
- B. Submit product information on all items to be used.

1.3 REFERENCES

- A. AWWA B300, Hypochlorites.
- B. AWWA B301, Liquid Chlorine.
- C. AWWA M20, Water Chlorination Principles and Practices.

1.4 GENERAL REQUIREMENTS

- A. Solder: Only lead-free solder shall be used on potable water systems.
- B. All work and products shall comply with the governing codes (reference Section 220500 General Plumbing Requirements).

**NISQUALLY STATE PARK
NEW FULL SERVICE PARK – PHASE 2**

PART 2 - PRODUCTS

2.1 ACCEPTABLE MANUFACTURERS

- A. Products shall comply with Section 220500 General Plumbing Requirements.
- B. Valves: Crane, Grinnell, Nibco, Stockham, Walworth, Milwaukee, Kitz, Red-White, Watts.
- C. Pressure Reducing Valves: Watts, Cla-Val, Bell & Gossett, Wilkins.
- D. Trap Primers: JR. Smith, Precision Plumbing Products.
- E. Backflow Preventers: Febco, Watts, Ames.
- F. Additional manufacturers are as listed for each individual item.

2.2 PIPE AND FITTINGS

- A. Pipe and fitting standards shall be as specified in Section 220520, Pipe and Pipe Fittings.
- B. Domestic Water Piping Located Above Ground: Type L copper tubing with solder joints and wrought copper or cast brass fittings.
- C. Domestic Water Piping Located Below Ground: Type K copper tubing with silver brazed joints and wrought copper or cast brass fittings.
- D. Trap Primer Piping: Type L or K "soft" or "hard" (bending temper) copper, with compression fittings or soldered joints.

2.3 VALVES

- A. Gate Valves:
 - 1. 3 Inches and Larger: 125 psi swp iron body gate, bronze mounted, bolted bonnet, OS&Y, flanged. Stockham No. G-623.
- B. Globe Valves:
 - 1. 2 1/2 Inches and Smaller: 125 psi swp bronze globe, threaded bonnet, teflon or bronze disc, solder or threaded connection. Stockham No. B-13T, B-14T, B 16, B-17.
 - 2. 3 Inches and Larger: 125 psi swp iron body globe, bronze mounted, bronze or teflon disc, flanged. Stockham No. G-512, G-514T.
- C. Ball Valves:
 - 1. 2-1/2 Inches and Smaller: 125 psi swp bronze ball, standard port, 2 piece construction, anti blowout stem, teflon seats, stainless steel or chrome plate ball, extended stem, memory stop, solder or threaded connections as required. Nibco S580, T580.

**NISQUALLY STATE PARK
NEW FULL SERVICE PARK – PHASE 2**

- D. Check Valves: Class 125 bronze check valve, horizontal swing, regrinding type, Y-pattern, renewable discs, complying with MSS SP-80.
- E. Pressure Reducing Valves:
 - 1. Bronze body construction, renewable nickel alloy seat, with integral strainer and union inlet connections. Adjustable range 25 to 75 lbs. Watts U5 or approved.
- F. Pressure Relief Valves: ASME rated pressure relief valve, set for pressure indicated or as required to protect system from over pressure. Valve shall have minimum 400,000 BTU/HR relief capability and no smaller than 3/4-inch connection sizes.
- G. Buried Site Isolation Valves: 200 psi nonshock water working pressure, iron body, bronze mounted, non-rising stem type, open counterclockwise, with "o-ring" type packing, standard 2-inch operating nut, complying with ANSI/AWWA C500. Furnish with operating wrench, length to suit installation.

2.4 SPECIALTIES

- A. Water Hammer Arrestors: All metal, factory precharged with inert gas, sealed internal bellows; 125 psi working pressure. All wetted parts shall be type 300 stainless steel, brass or copper. Zurn "Shoktrol", Wade "Shokstop", J. R. Smith "Hydrotrol", or Josam equivalent; in P.D.I. (Plumbing and Drainage Institute) sizes as indicated.
- B. Trap Primer Valve:
 - 1. For Single Drains: Cast bronze trap primer valve, 1/2-inch connections, for serving single floor drain. J.R. Smith No. 2699 or approved.
 - 2. For Single and Multiple Drains: Manufactured of corrosion resistant copper and brass, with valve and line pressure adjustment with manifold for serving multiple drains. Primer valve activated by drop-in water pressure. Precision Plumbing Products "Prime Rite" or approved.
 - 3. Valve Box: Cast iron box, rated for H2O loading, adjustable type with flanged top section and flared base. Style to suit valve used with and depth, and as acceptable to local code officials. Valve box cover shall be cast with words "WATER".

2.5 BACKFLOW PREVENTERS

- A. Reduced Pressure Type: Washington State approved, with air gap drain and resilient seated full flow shutoff valves and test cocks. Size [and capacity] as shown on drawings. Febco Models 825Y, 825 or approved.
- B. Double Check Type: Washington State approved, with resilient seated full flow shutoff valves and test cocks. Size [and capacity] as shown on the drawings. Febco Model 805, 805Y or approved.

2.6 DOMESTIC WATER DIAPHRAGM TANK

**NISQUALLY STATE PARK
NEW FULL SERVICE PARK – PHASE 2**

- A. Diaphragm type thermal expansion absorber. Amtrol or approved.
- B. Construction: Welded steel construction, with rigid polypropylene liner, butyl diaphragm, air charging valve, and ASME certified.
- C. Capacity: 4.7 gallon tank volume (minimum).

PART 3 - EXECUTION

3.1 INSTALLATION OF PIPING AND FITTINGS

- A. Installation and joining of all piping shall comply with Section 220520 Pipe & Pipe Fittings..
- B. Provide all non potable water, domestic hot water, and cold water piping as indicated and as required to allow supply connections to each fixture and equipment item requiring water supply.
- C. Run all piping concealed unless piping is specifically noted as to be run exposed.
- D. Provide supply connections to equipment furnished by others in accordance with Section 220500 General Plumbing Requirements.
- E. Install all piping sloped to low points to allow the system to be drained.

3.2 INSTALLATION OF VALVES

- A. For Valves 2-Inch and Smaller: Provide ball valves unless drawings indicate globe valves.
- B. Provide isolation valves as shown on the drawings. In addition to those shown, provide added valves to allow for the isolation of each group of fixtures and all individual equipment items.
- C. Install valves so as to be easily accessible and oriented to permit ease of operation. Valve stem shall be directed toward operator in either the vertical or horizontal direction. Provide access doors or panels to valves built into construction.
- D. Provide pressure reducing valves as shown on drawings, complete with by pass line, isolation valves, unions, and pressure gauges. Set initial pressure as shown, and adjust as required so that all fixtures/devices served have sufficient water pressure.
- E. Provide drain valves at the base of all risers.
- F. Provide drain valves at piping low points where the piping cannot be drained through fixtures or hose bibbs.
- G. Provide balancing valves in hot water circulation piping where indicated and where required to allow for equal distribution of hot water circulation flows.
- H. Butterfly valves installed at equipment or other system components which may be disconnected from the system shall be lug type suitable for dead end service. This includes butterfly valves at water heaters, pressure reducing valves, and similar equipment.

**NISQUALLY STATE PARK
NEW FULL SERVICE PARK – PHASE 2**

3.3 INSTALLATION OF SPECIALTIES

- A. Water Hammer Arrestors: Install per manufacturer's instructions. Provide ball isolation valve in piping to arrestor. Where access cannot be provided at water line location, extend water hammer arrestor piping and locate above ceiling outside of plumbing chase. Provide ceiling access doors as required. Provide water hammer arrestors at each flush valve or at the end of a bank of flush valves. Size water hammer arrestors per P.D.I.
- B. Trap Primers: Provide trap primers to all vented floor drains and where required by the governing code. Install as shown on drawings and provide with a isolation valve in the branch line to the trap primer valve.
- C. Access Covers and Doors: Provide access to all valves, water hammer arrestors, trap primers, backflow preventers, and any other piping accessories which would otherwise be inaccessible.
- D. Provide backflow preventers of type, and in locations, as shown on the drawings.
- E. Backflow devices shall be installed, inspected, and tested in accordance with the applicable portions of the Washington Administrative Code and other applicable regulations as set forth by the Washington State Department of Social and Health Services.
- F. Install heat tracing as shown on drawings and in accordance with manufacturer's instructions and NEC requirements.

3.4 WATER SERVICE CONNECTIONS

- A. Provide connection to water main outside the building as shown on the drawings.
- B. Provide sleeve in floor for entrance of service main into building, seal watertight; anchor service main firmly to building floor and walls. Seals shall comply with Section 220530 Piping Sleeves and Seals.

3.5 TESTING AND INSPECTION

- A. All piping shall be tested, inspected, and approved (by the local authority having jurisdiction) prior to being concealed or covered.
- B. Testing shall be witnessed by the plumbing inspector and the Architect/Engineer. Notify Architect/Engineer 48 hours prior to date of testing.
- C. Piping shall be hydrostatically tested for a period of 2 hours, during which time no drop in pressure or leakage shall occur.
- D. Test pressure shall be not less than 150 percent of the maximum to which the pipe will ordinarily be subjected; but in no case less than 150 psig.
- E. Any leaks or defective piping disclosed by testing and inspection shall be repaired with new materials and the system re tested.

**NISQUALLY STATE PARK
NEW FULL SERVICE PARK – PHASE 2**

3.6 FLUSHING AND DISINFECTION

- A. System Flushing: After tests are completed, all water piping shall be flushed. In general, sufficient water shall be used to produce a minimum water velocity of 2.5 feet per second through piping being flushed. Flushing shall be continued until discharge water shows no discoloration. System shall be drained at low points. Strainer screens shall be removed, cleaned, and replaced in line. System valves and fixture faucets shall be opened and re-closed to completely flush system. After flushing and cleaning, systems shall be prepared for disinfection service by immediately filling water piping with clean, fresh potable water. Any stoppage, discoloration, or other damage to the finish, furnishings, or parts of the building, due to the Contractor's failure to properly clean the piping system, shall be repaired by the Contractor.
- B. Upon completion of the job and prior to final acceptance, the plumbing system shall be disinfected with Chlorine solution. Review procedures and disinfection with the authority having jurisdiction to insure that all work complies with code requirements. Verify any deviations from specified procedures with the Engineer prior to proceeding. The chlorinating material shall be either liquid chlorine conforming to AWWA B301 or hypochlorite conforming to AWWA B300 (or as otherwise required by the authority having jurisdiction). Water chlorination procedure shall be in accordance with AWWA M20 (or procedure acceptable to authority having jurisdiction). The chlorinating material shall provide a dosage of not less than 50 parts per million and shall be introduced into the system in an approved manner. The treated water shall be retained in the pipe long enough to destroy all non spore forming bacteria.
- C. The retention time shall be at least 24 hours and shall produce not less than 10 ppm of chlorine at the extreme end of the system at the end of the retention period. All valves in the system being sterilized shall be opened and closed several times during the contact period. The system shall then be flushed with clean water until the residual chlorine is reduced to less than 1.0 ppm. During the flushing period all valves and faucets shall be opened and closed several times.
- D. The Contractor shall employ an approved agency to take test samples at several points of the system in properly sterilized containers and arrange with the Health Department having jurisdiction to test the samples. Should the samples not test satisfactory, the system shall be re sterilized and re flushed until satisfactory samples are obtained.
- E. The Contractor shall furnish a letter to the Engineer stating that Chlorination has been completed. The letter shall also include a copy of a certificate from the Health Department having jurisdiction stating that samples taken have been found acceptable.

END OF SECTION

**NISQUALLY STATE PARK
NEW FULL SERVICE PARK – PHASE 2**

SECTION 221123 – PUMPS

PART 1 - GENERAL

1.1 WORK INCLUDED

- A. Domestic Circulators.

1.2 SUBMITTALS

- A. All submittals shall comply with Section 220500 General Plumbing Requirements.
- B. Provide product information and performance data for all pumps.
- C. Performance data shall include pump curves, showing pump performance as head vs. GPM, BHP and NPSH vs. GPM, with system operating point clearly marked. (NPSH vs. GPM not required for pumps 1 HP and less.)

PART 2 - PRODUCTS

2.1 ACCEPTABLE MANUFACTURERS

- A. Products shall comply with Section 220500 General Plumbing Requirements.
- B. Domestic Circulators: Bell & Gossett, Grundfos, Armstrong.

2.2 GENERAL

- A. All rotating parts shall have been statically and dynamically balanced at the factory.
- B. Pumps shall operate at 1750 rpm unless indicated otherwise.
- C. Pump Capacity: Shall be no less than the values listed on the Mechanical Equipment Schedule on the drawings.
- D. Pump Types: The type of each pump is indicated on the Mechanical Equipment Schedule under the "Type" column and corresponds to the types specified herein.
- E. Motors: Shall comply with Section 220500 General Plumbing Requirements. Motors shall be of sufficient size so as to be non-overloading at any point on the operating curve and shall be no smaller than the size shown on the drawings. Motors shall be of drip-proof construction, unless indicated otherwise shall be 1750 rpm, resilient mounted with oil lubricated journal or ball bearings, and have built-in thermal overload protectors. Motors shall be for use with the voltage and phase as scheduled on the drawings.

**NISQUALLY STATE PARK
NEW FULL SERVICE PARK – PHASE 2**

- F. Controls: Furnish each pump with motor starter and overload protectors unless indicated otherwise.
- G. Bronze: Pumps used on domestic water systems shall be of all-bronze construction.
- H. Testing: All pumps shall be factory tested and thoroughly cleaned.
- I. Finish: Pumps shall have minimum one coat high grade machinery enamel finish, factory applied, manufacturer's standard color.

2.3 DOMESTIC CIRCULATORS

- A. Type: Centrifugal, single stage, wet rotor type.
- B. Construction: Bronze or stainless steel body; polypropylene, nylon, brass, or stainless steel impeller; ceramic or alloy steel shaft. Pump shall require no coupling or shaft seal for proper operation.
- C. Operating Range: Pump shall be suitable for 200 degree F operating temperature and 125 psig maximum working pressure.
- D. Motor: Motor shall be non-overloading at any point on the pump curve. Motor shall be integral to the pump; shall be cooled/lubricated by the pumped fluid; of quiet-operating construction; and shall be equipped with thermal overload protection.

PART 3 - EXECUTION

3.1 INSTALLATION

- A. Install pumps at locations shown on the drawings.
- B. Decrease from line size to pump inlet size with long radius reducing elbows and minimum 5-pipe diameter straight pipe into pump (except where suction diffusers are used). Where reducers (in the horizontal) are used on pumps, they shall be the eccentric type installed with taper on the bottom.
- C. Check motor alignment after pump installation, realign as necessary.
- D. Check pump operation to ensure that specified flows are provided, without motor unloading or pump cavitation. Notify the Architect/Engineer of any unusual conditions or performance other than as specified.

END OF SECTION

**NISQUALLY STATE PARK
NEW FULL SERVICE PARK – PHASE 2**

SECTION 221300 – SOIL WASTE AND VENT PIPING SYSTEM

PART 1 - GENERAL

1.1 WORK INCLUDED

- A. Soil, Waste and Vent Piping.
- B. Condensate, Overflow, Miscellaneous Drains.
- C. Cleanouts.
- D. Vent Flashing.
- E. Testing and Inspection.

1.2 SUBMITTALS

- A. Submittals shall comply with Section 220500 General Plumbing Requirements.
- B. Submit product information on all items to be used.

PART 2 - PRODUCTS

2.1 ACCEPTABLE MANUFACTURERS

- A. Products shall comply with Section 220500 General Plumbing Requirements.
- B. Cleanouts: Josam, Zurn, J. R. Smith, Wade.

2.2 PIPE AND FITTINGS

- A. Pipe and fitting standards shall be as specified in Section 220520, Pipe and Pipe Fittings.
- B. Piping 2 1/2 Inches and Smaller Located Above Ground:
 - 1. No hub cast iron pipe with mechanical joints; or copper DWV.
- C. Piping 3 Inches and Larger Located Above Ground and All Piping Located Below Ground:
 - 1. Cast iron soil pipe with bell and spigot joints; or
 - 2. No hub cast iron pipe with mechanical joints. Below ground mechanical joints shall have below ground couplings, shall be super duty stainless steel type. Type 304 stainless shield & bands. 24 gauge shield, neoprene rubber gasket. Bands shall tighten to 80 inch pounds. Husky SP 4000 or approved.

**NISQUALLY STATE PARK
NEW FULL SERVICE PARK – PHASE 2**

- D. Acid Waste and Vent Piping: As specified in Section 220520 Pipe & Pipe Fittings.
- E. Piping Exposed in Finished Areas: Chrome or nickel plated brass; piping 2 inches and larger may be provided with chrome or nickel plated brass sleeves to conceal pipe and fittings.
- F. Condensate Drains:
 - 1. Copper DWV or type M copper with soldered joints; or Solid Core, Schedule 40 PVC.

2.3 CLEANOUTS

A. General:

- 1. All cleanouts shall have cast iron bodies with bronze countersunk rectangular slotted plugs, lubricated with a non-hardening teflon base thread lubricant and having a gasket seal.
- 2. Cleanouts located in waterproof membrane floors shall be provided with an integral cast flange and flashing device.
- 3. All cleanouts shall be the same size as the pipe which they are intended to serve (but not larger than 4-inch).
- 4. Pipe fittings for cleanouts which turn through walls or up through floors shall use long sweep ells or a "Y" and 1/8 bend.
- 5. All cleanouts and access covers shall be provided with vandal proof screws.
- 6. Cleanouts in carpeted areas shall have cleanout marker.

B. Floor Cleanouts:

- 1. Areas with Floor Tile (or Linoleum): J. R. Smith No. 4140 Series adjustable floor level cleanout with round heavy duty nickel bronze top with tile recess.
- 2. Areas with Bare Concrete Floors: J. R. Smith No. 4100 Series stable floor level cleanout with round heavy duty nickel bronze top.
- 3. Areas with Terrazzo (and Similar Poured Floors): J. R. Smith No. 4180 Series adjustable floor level cleanout with round heavy duty nickel bronze top with terrazzo recess.
- 4. Areas with Carpet: J. R. Smith 4020-X Series adjustable floor level cleanout with round heavy duty nickel bronze top and carpet clamp.

C. Wall Cleanouts: Cast iron ferrule with cast bronze taper threaded plug, with plug tapped 1/4-inch, 20 thread, to accept access cover screw; with access cover. Access cover shall be stainless steel or chrome plated in "wet" areas (kitchen, lockers, restrooms) and prime painted steel elsewhere.

D. Outside Cleanouts: Heavy duty, round, cast iron, double-flanged housing, having scoriated cast iron cover with lifting device, ferrule and bronze closure plug. Housing and lid shall be galvanized and have vandal resistant screws. J. R. Smith No. 4251 or 4256 Series.

PART 3 - EXECUTION

3.1 INSTALLATION OF PIPE AND FITTINGS

**NISQUALLY STATE PARK
NEW FULL SERVICE PARK – PHASE 2**

- A. Installation and joining of all piping shall comply with Section 220520, Pipe and Pipe Fittings.
- B. Provide all soil, waste and vent piping as indicated and as required to allow waste and vent connections to each fixture and equipment item requiring connection.
- C. The work of this section shall include all sanitary sewer lines inside of the building and 5-feet outside of the building (unless indicated otherwise), to the point of and including connections to outside sanitary sewer lines or sanitary sewer manholes.
- D. The installation of all piping shall be in compliance with the Governing Codes.
- E. Install all horizontal soil or waste lines with a slope of 1/4-inch per foot. Exceptions require written approval of the Administrative Authority.
- F. Make all changes of direction and junctions with Y fittings and 1/8 bends; use sanitary tee fittings in vertical pipe only.
- G. Consult manufacturer's data and architectural drawings for information on plumbing fixtures before beginning rough in.
- H. Verify points of connection, invert elevations, and grade requirements before beginning installation.
- I. Coordinate installation of piping with all trades affected by installation.
- J. Stub all piping for all items requiring connection through wall or floor; cap and protect until connection to items is complete.
- K. Vents extending through roof shall terminate at least 10 inches above roofing; and not less than 10 feet from and 3 feet above any building opening.
- L. Vent Flashing: Provide vent flashing at each vent through roof; 4 lb. sheet lead, extending 10-inches all around pipe with sleeve to top of vent; counterflashing to overlap 2-inch and turn down inside the pipe (or similar water-proof methods as required to best suit roofing material/manufacturer).
- M. Connect equipment furnished by others in accord with Section 220500 General Plumbing Requirements.
- N. Trap all fixtures and equipment items as required by governing code; provide proper venting for each trap.
- O. All excavation, trenching and backfilling shall comply with Section 220510 Excavation & Backfill.
- P. Provide drain piping for all drip pans, unit condensate drains, unit P-traps, etc. Run piping to nearest point of drainage, or as shown on drawings. Where routing is not shown, route to nearest point of proper drainage.

3.2 INSTALLATION OF CLEANOUTS

**NISQUALLY STATE PARK
NEW FULL SERVICE PARK – PHASE 2**

- A. Install cleanouts in all soil and waste piping:
 - 1. At no more than 100 foot intervals on horizontal runs;
 - 2. At the end of all piping runs;
 - 3. At the base of all vertical risers.
 - 4. At all changes of direction for a run of 10 feet or over;
 - 5. At all locations shown on the drawings and where needed to correct possible stoppage and as required by governing code.
- B. Where cleanouts occur in concealed spaces provided extensions to floors above or to walls to allow access.
- C. Provide wall access covers for all wall cleanouts. See Section 220700 Piping Insulation for specification of wall access covers.
- D. Floor cleanouts shall be installed so as to be flush with the finished floor; where recessed cleanout covers are used the recess shall be filled flush with material to match the surrounding finished floor.
- E. Install cleanouts so as to assure proper clearances as required by governing code.
- F. All cleanouts located outside shall be provided with an access housing located in a 24" x 24" x 6" thick concrete pad, flush with the adjacent finished grade. The pipe and cleanout shall be independent of this access housing and pad.

3.3 TESTING AND INSPECTION

- A. All piping shall be tested, inspected and approved prior to being concealed or covered.
- B. Testing shall be by water or air, and shall comply with governing code.
- C. Testing shall be witnessed by the plumbing inspector and the Engineer's representative.
- D. Water Testing:
 - 1. Fill system with water so that there is no less than 10 feet of head above the highest system section being tested.
 - 2. System shall hold pressure for a period of at least 15 minutes with no leakage before the inspection starts.
 - 3. The system shall be inspected and shall hold tight with no leakage at all points.
- E. Air Testing:
 - 1. Pressurize system with air so that there is no less than 5 psig of air pressure in the system.
 - 2. System shall hold pressure for a period of at least 15 minutes without the introduction of additional air before the inspection starts.
 - 3. The system shall be inspected and shall hold tight with no leakage at all points.
- F. All leaks shall be eliminated and the system re-tested before proceeding with work or concealing pipe.

**NISQUALLY STATE PARK
NEW FULL SERVICE PARK – PHASE 2**

- G. All repairs to piping shall be with new material and no caulking of screwed joints or holes is allowed.

END OF SECTION

**NISQUALLY STATE PARK
NEW FULL SERVICE PARK – PHASE 2**

SECTION 221350 – ONSITE SEPTIC SYSTEM

PART 1 - GENERAL

1.1 SECTION INCLUDES

- A. This Section includes the work necessary to provide a complete and operational Onsite Septic System for Phase 2 Improvements.

1.2 RELATED SECTIONS

- A. Section 311100 – Clearing and Grubbing
- B. Section 312000 – Earth Moving
- C. Division 26 - Electrical

1.3 SUBMITTALS

- A. Submit under provisions of Section 013300 – Submittal Procedures.
- B. Product Data: Manufacturer's data sheets on each product to be used, including:
 - 1. Preparation instructions and recommendations.
 - 2. Shop Drawings.
 - 3. Storage and handling requirements and recommendations.
 - 4. Installation methods.

1.4 QUALITY ASSURANCE

- A. Installer Qualifications: Onsite Septic System Installer shall be listed on the Pierce County Certified Installer Firm found at <https://www.tpchd.org/home/showpublisheddocument/11223/638261494220500000>.

1.5 PERMITS

- A. Contractor is required to obtain the On-Site Septic System Permit from Tacoma-Pierce County Health Department prior to installation.

1.6 DELIVERY, STORAGE, AND HANDLING

- A. Store products in manufacturer's unopened packaging until ready for installation.

**NISQUALLY STATE PARK
NEW FULL SERVICE PARK – PHASE 2**

1.7 PROJECT CONDITIONS

- A. Maintain environmental conditions (temperature, humidity, and ventilation) within limits recommended by manufacturer for optimum results. Do not install products under environmental conditions outside manufacturer's recommended limits.

PART 2 - PRODUCTS

2.1 MANUFACTURER

- A. Provide specified products or approved equal.

2.2 MATERIALS

- A. Septic Tanks shall be composed of Class 3000 concrete minimum, two compartment, shall be watertight, and shall comply with ASTM C1227-Standard Specification for Precast Concrete Septic Tanks and the Washington State Department of Health requirements. Provide Septic Tanks of the size and capacity as noted in the Plans with 24" access risers and gas tight secure lids.
- B. Pump Chamber Tanks shall be composed of Class 3000 concrete minimum, one compartment, shall be watertight, and shall comply with ASTM C1227-Standard Specification for Precast Concrete Septic Tanks and the Washington State Department of Health requirements. Provide Pump Chamber Tanks of the size and capacity as noted in the Plans with 24" access risers and gas tight secure lids.
- C. Index Valve shall be Orenco V6600 or approved equal.
- D. Sand shall be ASTM C33 aggregate.
- E. Washed Rock shall be ¾" – 2-1/2" Washed Rock.
- F. Controller Panel shall be SJE Model IFS Rhombus (IFS 11W114H4AD8AC) of approved equal.
- G. Pump shall be Liberty Pump FL200 submersible effluent pump or approved equal. Pump shall be compatible with Controller Panel and shall be designed for 960 gallons per day minimum.
- H. Pump Chamber Pump (Administrative Building) shall be Hydromatic SP 50H or approved equal.
- I. All pressure pipe and fittings shall be Class 200 PVC.
- J. All sewer lines shall be 4" diameter SRD 35 PVC.
- K. Pressure and Gravity Sewer pipe sleeving (conduits) shall be Sch 40 PVC pipe-diameter size as noted on Plans.

**NISQUALLY STATE PARK
NEW FULL SERVICE PARK – PHASE 2**

PART 3 - EXECUTION

3.1 EXAMINATION

- A. Do not begin installation until subgrade have been properly prepared.
- B. If subgrade and trenching preparation is the responsibility of another installer, notify Owner of unsatisfactory preparation before proceeding.

3.2 PREPARATION

- A. Prepare trenching, pump, and Drainfield areas per Section 311100 – Clearing and Grubbing and Section 312000 – Earth Moving.
- B. Do not clear and grub Reserve Drainfield.

3.3 INSPECTION

- A. Onsite Septic System cannot be covered until the Engineer-of-Record and the Tacoma-Pierce County Health Department inspects and approves the installation. Contractor shall provide Engineer-of-Record and the Tacoma-Pierce County Health Department one calendar week of notice for inspections. Test Onsite Septic System in presence of Engineer-of-Record.
- B. Contractor shall provide Engineer-of-Record a completed Verification form.
- C. Contractor shall be responsible for all testing and constructing a complete and operational Onsite Septic System per the Plans and Specifications.

3.4 INSTALLATION, GENERAL

- A. Install units without damage to shape or finish. Replace or repair damaged units.
- B. Install units in alignment with adjacent work.
- C. Install Onsite Septic System in full compliance with Tacoma-Pierce County Department of Health Standards.
- D. Contractor shall install fully operational Onsite Septic System.

3.5 PROTECTION

- A. Protect installed products until completion of project.
- B. Touch-up, repair or replace damaged products before Substantial Completion.

END OF SECTION

**NISQUALLY STATE PARK
NEW FULL SERVICE PARK – PHASE 2**

SECTION 224000 – PLUMBING FIXTURES AND TRIM

PART 1 - GENERAL

1.1 WORK INCLUDED

- A. Plumbing Fixtures and Trim.
- B. Water Heaters.
- C. Adjustment and Cleaning.

1.2 DEFINITIONS

- A. "Plumbing Brass" means "P traps, stops, strainers, tailpieces, flanges, and other brass fittings and accessories NOT including faucets or stops."
- B. "Trim" includes all plumbing brass items, faucets, and any fixture accessories.

1.3 REFERENCES

- A. Uniform Plumbing Code.

1.4 SUBMITTALS

- A. All submittals shall comply with Section 220500 General Plumbing Requirements.
- B. Submit product data for all plumbing fixtures, plumbing trim, and water heaters.

1.5 GENERAL REQUIREMENTS

- A. Provide new fixtures and fittings, approved, free from flaws and blemishes with finished surfaces clear, smooth and bright. Visible parts of fixture brass and accessories, and all items located in accessible cabinet spaces, shall be heavily chrome plated. All stops risers, P-traps shall be chrome plated.
- B. All products and connections shall be in compliance with the Governing Code, the local Health Department, and Public Utilities Department.

PART 2 - PRODUCTS

2.1 ACCEPTABLE MANUFACTURERS

**NISQUALLY STATE PARK
NEW FULL SERVICE PARK – PHASE 2**

- A. Products shall comply with Section 220500 General Plumbing Requirements.
- B. Vitreous china and enameled cast iron fixtures: American Standard; Eljer; Kohler; Crane.
- C. Water Closet Seats: Church; Beneke; Olsonite; Kohler; Bemis.
- D. Carriers: Josam; J. R. Smith; Wade; Zurn; Watts Drainage.
- E. Stainless Steel Sinks: Elkay, Just.
- F. Hydrants and Hose Bibbs: Zurn; Woodford; Wade; J.R. Smith.
- G. Floor Drains: J. R. Smith; Wade; Zurn; Watts Drainage.
- H. Water Heaters: Chronomite, Rheem, A.O. Smith.
- I. Plumbing Brass: American Standard; Brasscraft; Chicago Faucet; Crane; Eljer; Frost; Kohler; Speakman; Symmons; T & S Brass; McGuire; Elkay; Eastman.
- J. Faucets: Chicago Faucet; T & S Brass.
- K. Flush Valves: Sloan Royal (NO SUBSTITUTIONS).

2.2 PLUMBING FIXTURES

- A. General:
 - 1. Plumbing Fixtures are listed below by reference numbers, corresponding to the reference number adjoining these items on the drawings.
 - 2. All vitreous china and enameled cast iron fixtures shall be finished white unless specifically noted otherwise.
 - 3. All stainless steel sinks shall be sound deadened, and shall have faucet ledge (except where noted specifically without ledge).
 - 4. In interests of Owner's Standardization, fixtures of similar type shall be product of one manufacturer; trim of similar type shall be product of one manufacturer.
- B. Water Closets:
 - 1. P-1A Water Closet – Wall Hung - Handicap:

Water Closet: Kohler "Kingston-Lite", No. K-4330, vitreous china, elongated bowl, wall mounted, siphon jet action bowl with 1 1/2" top spud, and 1.6 gallon flush. Wall mounted for handicap access. Verify with Architectural drawings for mounting heights and off-center stall dimensions.

Flush Valve: Sloan "Royal 111-1.5" chrome plated flush valve with vacuum breaker, quiet action, and screw driver stop. Provide with flush valve so that handle is on wide side of stall.

**NISQUALLY STATE PARK
NEW FULL SERVICE PARK – PHASE 2**

Seat: Kohler "Lustra", No. K-4670-SC, white plastic seat, open front and stainless steel self sustaining check hinge.

Carrier: Cast iron or steel construction, adjustable to support fixture. J. R. Smith "Linebacker" Figure 115 to 280, type to suit application. Provide with rear anchoring lug on single units.

Plumbing Brass: Chicago stop and chrome plated brass supply.

2. P-1B Water Closet - Wall Hung:

Water Closet: Kohler "Kingston-Lite", No. K-4330, vitreous china, elongated bowl, wall mounted, siphon jet action bowl with 1 1/2" top spud, and 1.6 gallon flush. Wall mounted for handicap access. Verify with Architectural drawings for mounting heights and off-center stall dimensions.

Flush Valve: Sloan "Royal 111-1.5" chrome plated flush valve with vacuum breaker, quiet action, and screw driver stop. Provide with flush valve so that handle is on wide side of stall.

Seat: Kohler "Lustra", No. K-4670-SC, white plastic seat, open front and stainless steel self sustaining check hinge.

Carrier: Cast iron or steel construction, adjustable to support fixture. J. R. Smith "Linebacker" Figure 115 to 280, type to suit application. Provide with rear anchoring lug on single units.

Plumbing Brass: Chicago stop and chrome plated brass supply.

3. P-1C Water Closet – Floor Mount - Handicap:

Water Closet: Kohler "Wellworth", No. K-3481, vitreous china, elongated bowl, floor mounted, flush tank, siphon jet action bowl with 1.6 gallon flush. Mounted for handicap access. Verify with Architectural drawings for mounting heights and off-center stall dimensions.

Seat: Kohler "Lustra", No. K-4670-SC, white plastic seat, open front and stainless steel self sustaining check hinge.

Plumbing Brass: Chicago loose key angle stop and brass supply

4. P-1D Water Closet – Floor Mount:

Water Closet: Kohler "Wellworth", No. K-3481, vitreous china, elongated bowl, floor mounted, flush tank, siphon jet action bowl with 1.6 gallon flush. Mounted for handicap access. Verify with Architectural drawings for mounting heights and off-center stall dimensions.

Seat: Kohler "Lustra", No. K-4670-SC, white plastic seat, open front and stainless steel self sustaining check hinge.

**NISQUALLY STATE PARK
NEW FULL SERVICE PARK – PHASE 2**

Plumbing Brass: Chicago loose key angle stop and brass supply

5. P-1E Water Closet – Wall Hung – Handicap:

Water Closet: Provide and install Acorn Dura-Ware Blowout Jet Toilet, Off-Floor Outlet. Toilet bowl shall be fabricated from 14 gage, type 304 stainless steel. Construction shall be seamless welded and exposed surfaces shall have a satin finish. Toilet shall be concealed blowout jet type with an elongated bowl, a self-draining flushing rim, and an integral contoured seat. Toilet shall meet ASME A112.19.3 and CSA B45.4 requirements and will flush with a minimum of 25 PSI flow pressure when used in conjunction with a minimum of 1.6 GPF. Toilet trap shall have a minimum 3-1/2" seal that shall pass a 2-1/8" diameter ball and be fully enclosed. Toilet waste outlet shall be a gasketed waste. Connecting hardware provided by installer. Fixture shall withstand loadings of 5,000 pounds without permanent damage. Fixture shall be furnished with necessary fasteners for proper installation.

Flush Valve: Sloan "Royal 142-1.6" chrome plated flush valve with vacuum breaker, quiet action, and screw driver stop. Provide with flush valve so that handle is on wide side of stall.

Carrier: Cast iron or steel construction, adjustable to support fixture. J. R. Smith "Linebacker" Figure 115 to 280, type to suit application. Provide with rear anchoring lug on single units.

Plumbing Brass: Chicago stop and chrome plated brass supply.

C. Lavatories:

1. P-3A Lavatory - Wall Hung - Handicap:

Lavatory: Kohler "Greenwich", No. K-2030, 20" x 18", vitreous china lavatory with 8" faucet centers, for use with concealed arm carrier.

Plumbing Brass: Kohler No. K-7715 lavatory drain with perforated grate and 1 1/4" offset tailpiece; Kohler No. K-8998, 1 1/4" Cast brass "P" trap with cleanout; loose key stops and flexible risers.

Faucet: Chicago Faucet No. 404 faucet, with no. 390 handles, 8" centers, vandal resistant, 1/2 GPM outlet/aerator, 5" spout.

Carrier: Steel construction, adjustable, anchored to floor, with concealed arms for high back lavatory support. J. R. Smith Figure 700 with accessories to suit application.

2. P-3B Lavatory – Counter Mounted:

Lavatory: Kohler Pennington, K2196. Vitreous china, self-rimming, 4" centers, white.

Plumbing Brass: Kohler No. K-7715 lavatory drain with perforated grate and 1 1/4" offset tailpiece; Kohler No. K-8998, 1 1/4" Cast brass "P" trap with cleanout; and Chicago Faucet loose key stops and flexible risers.

**NISQUALLY STATE PARK
NEW FULL SERVICE PARK – PHASE 2**

Faucet: Chicago faucet No. 797 faucet with No. 390 handles, 4" centers, 4" spout.

3. P-3C Lavatory – Counter Mounted – Handicap:

Lavatory: Kohler "Pennington", No. K-2196, 20" x 17", oval, vitreous china, self rimming, 4" centers, with overflow.

Plumbing Brass: Kohler No. K-7715 lavatory drain with perforated grate and 1 1/4" offset tailpiece; Kohler No. K-8998, 1 1/4" Cast brass "P" trap with cleanout; and loose key stops and flexible risers.

Faucet: Chicago Faucet No. 802 faucet, with no. 1000 handles, 4" centers, quarter turn cartridges, vandal resistant, 1/2 GPM outlet/aerator, 5" spout.

Insulation: Insulate trap, HW and CW supplies with Tru Bro Lav Guard or approved.

4. P-3D Hand Sink:

Lavatory: Elkay no. PSRADQ191955L Three hole drilled stainless steel sink 19" front-to-back x 19 1/2" left-to-right x 5-1/2" deep, self rimming sink with rear faucet ledge.

Plumbing Brass: Elkay No. LK-335, stainless steel cup strainer with 1-1/2" stainless steel tailpieces, cast brass "P" traps each with a cleanout, angle stops and flexible risers.

Faucet: Chicago Faucet No. 1100 faucet, with no. 317 wrist blade handles, 8" centers, vandal resistant, 5 1/4" gooseneck, 2 GPM outlet/aerator, quaturn cartridges.

5. P-3E Lavatory - Wall Hung - Handicap:

Lavatory: Acorn "Meridian" Stainless Steel Straight Front Uni Basin. Heavy gauge, 304 stainless steel. Countertop, backsplash, and housing fully welded with integral round basin. With grid strainer, waste piping and 1-1/2" P-trap. Lavatory to include backsplash mounted pushbutton and stainless steel tubular spout with 0.5 GPM flow control and adjustable metering up to 60 seconds. Lavatory faucet to include integral mixing valve field set to 105 F and to include integral strainers and check valves. Trap enclosure assembly to be fabricated of 304 stainless steel.

Carrier: Steel construction, adjustable, anchored to floor, with concealed arms for high back lavatory support. J. R. Smith Figure 700 with accessories to suit application.

D. Sinks:

1. P-5A Sink – Two Compartment:

Sink: Elkay No. DLR 331910 multi-hole drill, 18 gauge, Type 304 stainless steel, 19 1/2" front-to-back x 33" left-to-right x 10" deep self rimming sink with back faucet ledge.

Plumbing Brass: Elkay No. LK-358, stainless steel cup strainer with 1-1/2" stainless steel tailpieces, cast brass "P" traps each with a cleanout, angle stops and flexible risers.

**NISQUALLY STATE PARK
NEW FULL SERVICE PARK – PHASE 2**

Faucet: Chicago Faucet No. 2300-8CP single handle deck mount sink faucet with E12 aerator, 8” center mounting.

2. P-6A Service Sink:

Sink: Swanstone MS 2424 mop sink. Molded composite, 24”x24” basin. Provide vinyl rim guard and stainless steel wall guard.

Plumbing Brass: 3” cast brass drain, dome strainer and lint basket.

Faucet: Chicago faucet No. 897 wall mounted. Vacuum breaker spout with pail hook and wall brace. ¾” hose thread outlet, Quatern ceramic cartridges, adjustable supply arms, rough chrome finish.

E. Drinking Fountains

1. P-8A Interior Drinking Fountain – Dual Height – Handicap:

Fixture: Halsey Taylor hydroboost bi-level with back panel. Push button on front ADA, stainless steel, chrome plated brass bubbler with guard. Integral water cooler and sensor-activated bottle filler.

2. P-8B Exterior Drinking Fountain – Dual Height – Handicap:

Fixture: MDF Model 10485WM bi-level with button-activated bottle filler. Push button on front ADA, stainless steel, stainless steel or chrome plated brass bubbler with guard. Custom color by Architect.

F. Showers

1. P-9A Shower – Handicap:

Shower Unit: Symmons Model No. C-96-300-B30-V. Unit shall be No. T-300-V wall/hand shower with 5 foot flexible metal hose, in-line vacuum breaker and wall connection, 30 inch slide bar for mounting hand shower, No. 46-1X Temptrol pressure-balancing mixing valve with piston, integral thermometer, adjustable stop to limit handle turn.

2. P-9B Tub/Shower:

Shower Unit: Symmons Model No. C-96-400-B30-V. Unit shall be No. T-300-V tub/hand shower with 5 foot flexible metal hose, in-line vacuum breaker and wall connection, 30 inch slide bar for mounting hand shower, diverter tub spout, No. 46-1X Temptrol pressure-balancing mixing valve with piston, integral thermometer, adjustable stop to limit handle turn.

G. Hydrants and Hose Bibbs:

1. P-10A Wall Hydrant - Non-Freeze:

**NISQUALLY STATE PARK
NEW FULL SERVICE PARK – PHASE 2**

Zurn No. Z-1300 recessed box wall hydrant, non-freeze type, with polished bronze box and bronze hinged cover, integral vacuum breaker, "T" handle key and 3/4" inlet, 3/4" hose outlet, and "A" dimension of at least 8".

2. P-10B Wall Hydrant:

Zurn No. Z-1300 recessed box wall hydrant, non-freeze type, with polished bronze box and bronze hinged cover, integral vacuum breaker, "T" handle key and 3/4" inlet, 3/4" hose outlet, and "A" dimension of at least 8".

H. Floor Drains

1. P-11A Floor Drain:

JR Smith Fig. 2005. Cast iron drain body with round nickel-bronze strainer. Vandal-proof screws

2. P-11B Trough Drain:

JR Smith Fig. 9667 Stainless steel shower drain system. 18 Gage type 304 stainless steel construction, Slotted Grate, flashing skirt.

I. Wall Boxes:

1. P-12A Refrigerator Icemaker Connection:

Provide cold water supply and shutoff in outlet box

Guy Gray Model No. FBB-200TS, top supply, 1/2" brass supply sweat connection and valves.

2. P-12B Clothes Washer Connection:

Provide shutoffs, water and waste for owner's appliance in outlet box.

Guy Gray Model No. B200 galvanized steel box with brass hose bibs and 2" stand pipe connection.

Fittings: Precision Plumbing Products No. WHA-500L Shock Arrestors. Steel braided hoses to connect washer.

3. P-12C Dishwasher Connection:

Provide shut-offs, water and waste for owner's appliance in outlet box.

Stainless Steel braided supply hoses to connect washer. PVC Airgap Fitting mounted at adjacent sink. 5/8" drain hose.

J. Eyewash:

1. P-13A Eyewash Station:

**NISQUALLY STATE PARK
NEW FULL SERVICE PARK – PHASE 2**

Acorn Model S0420 Wall-Mount eyewash station with ABS plastic 11-3/4” diameter bowl, ANSI-compliant identification sign, and ABS plastic Eye/Face wash heads supplied by a combined integral Flow Control, with integral flip Dust Covers, internal Flow Controls and Filters to remove debris from the water. Flow control to include integral mixing valve field set to 85 F and to include integral strainers and check valves.

K. Instantaneous Water Heaters:

1. Type: Electric, point-of-use instantaneous booster type heaters.
2. Construction: Stainless steel heating elements, Celcon or copper or stainless steel waterways, with plastic (or steel) enclosure. Unit shall be for use with electricity as scheduled on the plans. Unit shall be UL listed and meet all applicable codes.
3. Capacity: Shall be as indicated on the plans. Unit shall be for use with 120F outlet temperatures, flow rates from 1.0 to 3.0 gpm, and 25 psig inlet water pressure.

L. Water Heaters

1. Type: Hybrid electric tank, air-to-water heat pump
 - a. Construction: Integrated air-to-water heat pump unit, stainless steel backup heating elements, Celcon or copper or stainless steel water ways, with plastic or steel enclosure. Self-diagnostic electronic control featuring digital readout of water temperature set point. Front access cover to equipment shall be installed to be easily accessible.
 - b. Capacity: Shall be as indicated on the plans. Unit shall be for use with 95 – 150 F outlet temperatures.
 - c. Unit shall be for use with electricity as scheduled on the plans. Unit shall be UL listed and meet all applicable codes. Unit shall have a minimum 6-year warranty.

2.3 SPECIALTIES

A. Unless indicated otherwise, the following fittings and materials shall be used:

1. Fixture Traps: 17 gauge seamless chrome plated tubing, with 2 inch minimum seal, size as required by Uniform Plumbing Code and to suit construction.
2. Exposed piping and fittings in finished areas and in accessible cabinets: Chrome plated or sleeved with chromed sleeves; all chrome to have a bright polished finish. No exposed copper allowed (includes accessible cabinet areas).
3. Stops: 1/4 turn ball valve type. Stops shall be with loose key.
4. Escutcheons: Chrome plated, one piece.

B. Rims: Lavatories and sinks mounted in the counterwork shall be self rimming or equipped with deck stainless steel rims similar and equal to the Hudee Rim.

C. Vacuum Breakers: Anti siphon vacuum breaker, by same manufacturer as flush valve or faucet with which used.

D. Carriers: Provided for wall mounted fixtures, type to suit construction. J.R. Smith or equal.

**NISQUALLY STATE PARK
NEW FULL SERVICE PARK – PHASE 2**

- E. Sealant: Silicone type, General Electric type SCS1202 series or Dow Chemical equal, color to match fixture.

PART 3 - EXECUTION

3.1 INSTALLATION OF FIXTURES

- A. All fixtures shall be completely connected to piping as needed to make a complete and operable installation.
- B. All wall mounted water closets, urinals, lavatories, drinking fountains and sinks shall be installed with supporting carriers that transmit the load to the floor.
- C. All wall mounted fixtures that standard carriers are not manufactured for, shall be supported with bolts through the wall which attach to a 3/16" thick steel back plate for block walls and wood stud walls; or a 2" x 2" x 1/4" angle welded to at least four studs for metal stud walls.
- D. Where plumbing fixtures abut to walls and floors, seal all joints with a uniform fillet bead of silicone sealant.
- E. Mounting heights and locations of fixtures shall be as shown on the Architectural drawings; these locations shall be verified and coordinated with the various trades affected by the installation of these fixtures. When not indicated or shown, obtain mounting location and heights from the Architect/Engineer prior to installation.
- F. Protect fixtures against use and damage during construction; provide guards and/or boxing as required.
- G. Pipe all pressure relief valves to nearest floor drain.
- H. In toilet rooms where only one (1) urinal is shown, that urinal shall be ADA accessible.

3.2 INSTALLATION OF SPECIALTIES

- A. Escutcheons: Provide escutcheons at each point where an exposed pipe or other fitting passes through walls, floors, backs of cabinets or ceilings.
- B. Stops: Provide stops in all water connections to all lavatories and sinks.
- C. Vacuum Breakers: Provide vacuum breakers with all flush valves and service sink faucets and where indicated on the drawings.

3.3 ADJUSTMENT AND CLEANING

- A. After completion of installation remove all labels and thoroughly clean all fixtures, trim and fittings.

**NISQUALLY STATE PARK
NEW FULL SERVICE PARK – PHASE 2**

- B. Adjust all flush valves, fixture stops, valves, and associated plumbing items as necessary for the proper operation of all equipment.

END OF SECTION

**NISQUALLY STATE PARK
NEW FULL SERVICE PARK – PHASE 2**

SECTION 224010 – PUMPHOUSE PLUMBING

PART 1 - GENERAL

1.1 SUMMARY

- A. This Section includes the procurement and installation of pumphouse fixtures and appurtenances.

1.2 RELATED DOCUMENTS

- A. Drawings and general provisions of the Contract, including General Conditions and Division 01 Specification Sections apply to this Section.

1.3 STANDARD SPECIFICATIONS

- A. All work to be performed and materials to be used shall be in accordance with the current edition of the Standard Specifications for Road, Bridge, and Municipal Construction, and the current Standard Plans as published by the Washington State Department of Transportation (WSDOT), unless otherwise indicated herein.
- B. Contractor shall have one (1) copy of the current edition of the Standard Specifications and all amendments therein, and applicable WSDOT Standard Plans at job site.
- C. All work shall conform to the specifications listed in the following:
 - 1. WAC 176-160 (Minimum Standards for Construction and Maintenance of Wells)
 - 2. WAC 173-162 (Regulation and Licensing of Well Contractors and Operators)
 - 3. WAC 246-290 (regulations pertaining to Public Water Systems)
 - 4. The Washington State Department of Health (WSDOH) Water System Design Manual
 - 5. APWA Standard Specifications
 - 6. AWWA Standards
 - 7. UPC Standards
 - 8. All other applicable county rules, regulations, and ordinances.
- D. Execute and inspect all electrical work in accordance with Underwriters Laboratories (UL), and all local and state codes, rules and regulations applicable to the trade affected as a minimum, but if the plans and/or specifications call for requirements that exceed these rules and regulations, the more stringent requirement shall be followed. Follow application sections and requirements and testing procedures of NFPA, IEEE, NEMA, CBM, ANSI, NECA, ICEA, and NETA.

1.4 SUBMITTALS

- A. Product Data: Submit manufacturer's product data, standard drawings, and catalog cuts for all pumphouse plumbing fixtures including but not limited to the following:

**NISQUALLY STATE PARK
NEW FULL SERVICE PARK – PHASE 2**

1. PVC Pipe and Fittings
2. Joining Materials
3. Meter(s), Valves, and Appurtenances
4. Pressure Tank
5. Fire Pump
6. Fire Sprinkler Tank
7. All miscellaneous components and appurtenances

- B. Shop Drawings: Supplier shall submit shop drawings. Shop drawings shall include material descriptions, specifications, dimensional and assembly drawings, installation instructions, parts lists, and job specific drawings.

1.5 QUALITY ASSURANCE

- A. Contractor is responsible for all effort necessary to complete work in accordance with drawings and standards, until certified by the engineer and state and local agencies for correct installation and satisfactory operation of all equipment.

1.6 DELIVERY, STORAGE, AND HANDLING

- A. All equipment and materials shall be new and shall bear the manufacturers name and trade name.
- B. All material and equipment shall be protected against dirt, dust, water and chemical or mechanical injury, vandalism, and theft. Materials shall not be dropped, subjected to heavy impacts, bent, or subjected to abrasion. Any physical damage to the components shall be repaired or replaced by the contractor at the contractor's expense.

PART 2 - PRODUCTS

2.1 PVC PIPE AND FITTINGS

- A. PVC, Schedule 80 Pipe: ASTM D 1785.
1. PVC, Schedule 80 Socket Fittings: ASTM D 2467.
 2. PVC, Schedule 80 Threaded Fittings: ASTM D 2464.
- B. AWWA C900 PVC
1. To be used in fire flow applications.
 2. Joints shall be restrained.

2.2 JOINING MATERIALS

- A. Type and material recommended by piping system manufacturer, unless otherwise indicated. Must have pressure rating at least equal to piping being joined.

**NISQUALLY STATE PARK
NEW FULL SERVICE PARK – PHASE 2**

2.3 PIPING SPECIALTIES

- A. Transition Fittings: Manufactured fitting or coupling same size as piping to be joined, with pressure rating at least equal to and ends compatible with piping.

2.4 BALL VALVES

- A. Ball Valves (Above Grade Piping):
1. PVC Schedule 80 Ball Valve less than 4 inches:
 - a. True Union Type
 - b. CWP Rating: 200 psi minimum
 - c. Full Port Opening
 - d. NSF Approved

2.5 SPRINKLER TEMPORARY WATER TANK

- A. Basis of Design Product: Norwesco 5000 Gallon Vertical Storage Tank
1. Tank shall be supplied and installed meeting the requirements shown in the Plans.
 2. Tank shall be insulated meeting the following requirements:
 - a. Tank shall be wrapped with 2” fiberglass insulation, minimum R value 5. Secure to tank body with 3/4” stainless steel bands every 1-foot minimum.
 - b. Insulation shall be wrapped with EPDM rubber sheeting, approved for roofing applications. Rubber shall be 60-mil thickness minimum. Secure to tank body with 3/4” stainless steel bands every 2 feet minimum.
 - c. Seal joints with exterior-rated roofing seam tape.
 - d. Submit proposed insulation method to Engineer prior to construction.
 3. Tank shall be heated with 1500-watt sinking water deicer.
 - a. Deicer shall be Allied Precision Sinking Pond Deicer, or approved equivalent.
 - b. Deicer shall be provided with thermostat control, located inside pumphouse.
- B. Water tank Auto-Fill Float Control
1. Float control shall be potable-water rated, capable of triggering float-activated water tank fill valve.
- C. Float-Activated Water Tank Fill Valve
1. Valve shall be potable-rated stainless steel w/ 2” female NPT inlet and outlet.
 2. Valve shall be automatically operated based upon status of Water tank Auto-Fill Float Control.

2.6 HYDROPNEUMATIC TANKS

**NISQUALLY STATE PARK
NEW FULL SERVICE PARK – PHASE 2**

- A. Bladder Tanks:
1. Basis of Design Product: Elbi America WTL-300. Subject to compliance with requirements, provide the products indicated on Drawings or an engineer approved equivalent.
 - a. Pressure Rating: 150 psi minimum
 - b. Tank Volume: 80 gallons Total acceptance volume
 - c. Minimum Drawdown Volume: 17 gallons available between cut-in pressure of 60 psi and cut-out pressure of 40 psi.
- B. Tanks must comply with chapter 70.79 of the Revised Code of Washington (RCW) and the Department of Labor and Industries (L&I) regulation.
1. These regulations require all pressure tanks more than 5 cubic feet (37.5 gallons) to be constructed according to the latest edition of ASME specifications code (RCW 70.79.080)
 2. Must meet the construction requirements of chapter 296-104 WAC.

2.7 TEMPORARY FIRE PUMP

- A. Basis of Design Product: Grundfos CR 32-2-1 A-G-A-E-HQQE.
1. Capable of minimum 150 GPM at 115 feet total dynamic head.

2.8 FIRE PUMP AND WATER TANK CONTROL PANEL

- A. Fire Pump control panel shall be for simplex pump controls meeting the following criteria:
1. NEMA 4 enclosure
 2. 7.5 hp, 3ph, 208v, 60hz
 3. Main disconnect switch w/ door
 4. Motor protector IEC starters
 5. Control power transformer
 6. Transformer primary fuse protection
 7. HAND-OFF-AUTO selector switch
 8. Terminals for all field wiring connections
 9. Terminals for motor over-temperature cut-outs
 10. UL 508A label
- B. Water tank control shall include thermostat control for tank heater.

PART 3 - EXECUTION

3.1 PIPING APPLICATIONS

- A. General: Use pipe, fittings, and joining methods for piping systems according to the following applications.

**NISQUALLY STATE PARK
NEW FULL SERVICE PARK – PHASE 2**

- B. Transition couplings and special fittings with pressure ratings at least equal to piping pressure rating may be used, unless otherwise indicated.
- C. Do not use flanges or unions for underground piping.
- D. Flanges, unions, grooved-end-pipe couplings, and special fittings may be used on aboveground piping and piping in vaults.

3.2 PIPING INSTALLATION

- A. Drawing plans, schematics, and diagrams indicate general location and arrangement of piping systems. Indicated locations and arrangements were used to size pipe and calculate friction loss, expansion, pump sizing, and other design considerations. Install piping as indicated unless deviations to layout are approved on the Coordination Drawings.
- B. Install PVC, AWWA pipe according to ASTM F 645 and AWWA M23 and WSDOT Standard Specifications Section 7-09.3.
- C. Install sleeves for pipes passing through concrete and masonry walls and concrete floor and slabs.
 - 1. Cut sleeves to length for mounting flush with both surfaces.
 - a. Exception: Extend sleeves installed in floors of equipment areas or other wet areas 2 inches above finished floor level.
 - 2. Install sleeves in new walls and slabs as new walls and slabs are constructed. Sleeves shall be PVC Pipe.

3.3 FITTING AND JOINT CONSTRUCTION

- A. Make pipe joints according to the following:
 - 1. Fittings and joints shall be installed in accordance with the manufacturers printed specifications and instructions, and to the standards of AWWA for the type of pipe used.

3.4 ANCHORAGE INSTALLATION

- A. Securely anchor above ground piping to pump house floor or wall with manufacturer approved fittings.

3.5 VALVE INSTALLATION

- A. AWWA Gate Valves: Comply with AWWA C600 and AWWA M44.
- B. Ball Valves: Comply with manufacturer recommendations.
- C. Pressure Sustaining Valves: Comply with manufacturer recommendations.

**NISQUALLY STATE PARK
NEW FULL SERVICE PARK – PHASE 2**

- D. Relief Valves: Comply with AWWA C512. Install aboveground with shutoff valve on inlet.

3.6 CONNECTIONS

- A. Connect water-distribution piping to interior domestic water piping
- B. Install unions in above ground piping 3” and smaller, adjacent to each valve and at final connection to each piece of equipment.
- C. Connect pressure switches to pump motor controls per manufacturer’s requirements and applicable electrical code.
- D. Connect reservoir level controls to booster pump skid input.

3.7 HYDROPNEUMATIC TANKS

- A. Must meet the construction and installation requirements of chapter 296-104 WAC, but is exempt from routine L&I inspections and fees (RCW 70.79.090(6)).
 - 1. Maximum allowable working pressure shall be 150 psi.
- B. Pressure Relief Valve
 - 1. Tanks must be protected against over-pressurization with a properly sized and installed ASME-approved pressure relief valve (PRV) (WAC 29-104-316).
 - a. Must be installed as close as possible to the vessel without any valves between the PRV and the pressure tank.
 - b. The set pressure of the PRV must not exceed the design pressure of the vessel or the pressure vessel manufactures requirements.
- C. Must meet the installation requirements of chapter 296-104 WAC, but is exempt from routine L&I inspections and fees (RCW 70.79.090(6)).

3.8 CLEANING AND DISINFECTION

- A. Clean and disinfect water-distribution piping as required by WSDOT Standard Specification Section 7-09.3(24).

END OF SECTION

**NISQUALLY STATE PARK
NEW FULL SERVICE PARK – PHASE 2**

SECTION 230500 – GENERAL HVAC REQUIREMENTS

PART 1 - GENERAL

1.1 WORK INCLUDED

- A. General HVAC Requirements.
- B. HVAC Submittals.
- C. Motors.
- D. Equipment and Piping Identification.
- E. Commissioning

1.2 GENERAL

- A. Includes, but not limited to, furnishing labor, materials, and equipment for completion of work unless indicated or noted otherwise.
- B. All work included in Division 23 shall be the responsibility of a single HVAC Subcontractor. This Contractor shall obtain and pay for all permits required by State and local authorities governing the installation of the HVAC work. It is the Contractor's responsibility to contact all utility organizations serving the building, prior to bid, and to include all charges for inspections, installation of materials, equipment and connection of all required utilities.
- C. Furnish exact location of electrical connections and complete information on motor controls to Division 26.
- D. The drawings and specifications are complementary and what is called for in either is binding as if called for in both.
- E. The ductwork and accessibility to HVAC equipment shall take precedence over all other equipment in the ceiling interstitial spaces or other mechanical areas including, but not limited to, domestic water piping and electrical conduit.
- F. All HVAC equipment and devices furnished or installed under other Divisions of this specification which require connection to any mechanical systems (i.e., plumbing systems or duct systems, or controls) shall be connected under this division of the Specifications.
- G. The Contractor shall be responsible for checking field conditions and verifying all measurements and relationships indicated on the drawings before proceeding with the work.

1.3 ELECTRICAL

**NISQUALLY STATE PARK
NEW FULL SERVICE PARK – PHASE 2**

- A. All electrical work, conduit, boxes and devices in connection with control wiring as required to install the control equipment as specified herein or shown on the drawings shall be furnished and installed complete by the Division 23 Contractor.
- B. All electrical work performed under this section of the Specifications shall conform to all applicable portions of the Division 26 specifications and shall conform to all governing codes.
- C. All equipment shall be factory wired to a junction box for connection to electrical service.
- D. Where a piece of equipment specified includes an electric motor, the motor shall be furnished and mounted by this Contractor. Motor starter, disconnect switches and wiring from the electrical panel to the motor control devices and to the motor shall be provided by the Division 26 Contractor unless stated otherwise in the HVAC specification and on the HVAC equipment schedule.

1.4 SYSTEMS DESCRIPTION

- A. Site Inspection:
 - 1. Examine premises and understand the conditions which may affect performance of work of this Division before submitting proposals for this work.
 - 2. No subsequent allowance for time or money will be considered for any consequence related to failure to examine site conditions.
- B. Drawings:
 - 1. HVAC drawings show general arrangement of ductwork, equipment, etc. Follow as closely as actual building construction and work of other trades will permit.
 - 2. Consider electrical drawings part of this work insofar as these drawings furnish information relating to design and construction of building.
 - 3. Because of small scale of HVAC drawings, it is not possible to indicate all offsets, fittings, and accessories which may be required. Investigate structural and finish conditions affecting this work and arrange work accordingly, providing such fittings, valves, and accessories required to meet conditions.

1.5 SUBMITTALS

- A. All material used on the project shall be new and free of defects. The Engineer reserves the right to reject any material, the appearance of which has been damaged on the site or in shipment. The material shall be of approved equal quality to that which is specified. Should the make and type of material differ from that specified, the Contractor may be required to submit catalog and engineering data (samples if requested) necessary to make a comparison and determine its suitability. The Contractor shall also bear the cost of any changes to the electrical design made necessary by any approved substitutions.
- B. The Contractor shall submit to the Engineer, for approval, complete information on all equipment and materials to be provided on the project including six copies of the manufacturer's catalog and engineering data, shop drawings of shop fabricated equipment and instruction data for each item included under this section of the specifications. Submittals shall be presented to the Engineer

**NISQUALLY STATE PARK
NEW FULL SERVICE PARK – PHASE 2**

within 30 calendar days from the date of the contract signing in complete indexed and bound sets. The Contractor shall submit a typed, signed list including all items to be furnished on the project. The signature on the aforementioned list shall indicate that the contractor has examined the suitability of all material and equipment with respect to compliance with these specifications. The Contractor's approval shall also indicate that physical dimensions of the equipment have been verified with the installation requirements and were found to cause no interference therewith.

- C. Review of submittal data by the Engineer or Engineer does not relieve the Contractor of responsibility for quantities, measurements, and compliance with the intent of all contract documents.
- D. Furnish submittals on all items and equipment specified in Division 23 and all items indicated on HVAC drawings in a hard-back, three-ring binder.
- E. The Contractor shall submit the HVAC cost breakdown including all sub-contractors costs.

1.6 OPERATION AND MAINTENANCE MANUAL FOR HVAC SYSTEMS

- A. Bind Operation & Maintenance Manual for HVAC Systems in three-ring, hard-backed binder with clear plastic pocket on spine. Spine of each binder shall have following typewritten lettering inserted:

**OPERATION AND MAINTENANCE MANUAL
FOR HVAC SYSTEMS**

- A. Provide master index at beginning of Manual showing items included. Use plastic tab indexes for sections of Manual.
- B. First section shall consist of name, address, and phone number of Engineer, General Contractor, and Mechanical, Plumbing, Sheet Metal, Refrigeration, Temperature control, and Electrical subcontractors. Also include complete list of equipment installed with name, address, and phone number of each vendor.
- C. Provide section for each type of item of equipment.
- D. Submit copies of Operation & Maintenance Manual to Engineer for approval.
- E. Include descriptive literature (Manufacturer's catalog data) of each manufactured item. Literature shall show capacities and size of equipment used and be marked indicating each specific item with applicable data underlined.
- F. Operating Instructions shall include:
 - 1. General description of each HVAC system.
 - 2. Step-by-step procedure to follow in putting each piece of HVAC equipment into operation.
- G. Maintenance Instructions shall include:
 - 1. Manufacturer's maintenance instructions for each piece of HVAC equipment installed in Project. Instructions shall include name of vendor, installation instructions, parts numbers and lists operation instructions of equipment, and maintenance and lubrication instruction.

**NISQUALLY STATE PARK
NEW FULL SERVICE PARK – PHASE 2**

2. Summary list of HVAC equipment requiring lubrication showing name of equipment, location, and type and frequency of lubrication.
3. List of HVAC equipment used indicating name, model, serial number, and nameplate data of each item together with number and name associated with each system item.

1.7 QUALITY ASSURANCE

- A. Requirements of Regulatory Agencies:
 1. Perform work in accordance with applicable Codes.
 2. In case of differences between building codes, state laws, local ordinances, utility company regulations, and Contract Documents, the most stringent shall govern.
- B. Product Approvals: See paragraphs elsewhere in this specification.
- C. Manufacture: Use domestic made duct, duct fittings, and motors on Project.
- D. Identification: Motor and equipment name plates as well as applicable UL and AGA labels shall be in place when Project is turned over to Owner.

1.8 CODES AND STANDARDS

- A. Codes and agencies having jurisdictional authority over HVAC installation.
 1. Washington State Energy Code
 2. International Building Code -- Latest Approved Edition
 3. International Mechanical Code -- Latest Approved Edition
 4. International Fuel Gas Code – Latest Approved Edition
 5. State and County Department of Health
 6. Occupational Safety and Health Administration (OSHA)
 7. Washington Industrial Safety and Health Act (WISHA)

1.9 PRODUCT HANDLING AND PROTECTION

- A. Contractor is responsible for protection of all material, equipment and apparatus provided under this section from damage, water, corrosion, freezing and dust, both in storage and when installed, until final project acceptance.
- B. Provide temporary heated and sheltered storage facilities for material and equipment.
- C. Completely cover motors and other moving machinery to protect from dirt and water during construction.
- D. Handle and protect equipment and/or material in manner precluding unnecessary fire hazard.
- E. Equipment requiring rotation and/or lubrication during storage shall have records maintained and witnessed on a monthly basis and forwarded to the Engineer prior to acceptance.
- F. Material or equipment damaged because of improper storage or protection will be rejected.

**NISQUALLY STATE PARK
NEW FULL SERVICE PARK – PHASE 2**

- G. Equipment finish that is damaged by handling, storage, etc. shall be corrected by the Contractor at no additional cost to the Owner.

1.10 WARRANTIES

- A. In addition to guarantee specified in General Conditions, guarantee heating, cooling, and plumbing systems to be free from noise in operation that may develop from failure to construct system in accordance with Contract Documents.
- B. In order to be protected, secure proper guarantees from suppliers and subcontractors.
- C. Provide certificates of warranty for each piece of equipment. Clearly record "start-up" date of each piece of equipment on certificate. Include certificates as part of Operation & Maintenance Manual.

1.11 ABBREVIATIONS

1.	AFF	Above Finish Floor
2.	AMCA	Air Moving & Conditioning Association
3.	ANSI	American National Standards Institute
4.	APWA	American Public Works Association
5.	ARI	Air Conditioning and Refrigeration Institute
6.	ASHRAE	American Society of Heating, Refrigerating and Air Conditioning Engineers
7.	ASME	American Society of Mechanical Engineers
8.	ASTM	American Society of Testing & Materials
9.	AWWA	American Water Works Association
10.	BFF	Below Finish Floor
11.	BHP	Brake Horsepower
12.	BTU	British Thermal Unit
13.	CFC	Chloro – Fluorocarbon
14.	CFM	Cubic Feet per Minute
15.	DOT	US Department of Transportation
16.	EPA	Environmental Protection Agency
17.	fpm	feet per minute
18.	FS or Fed.	Spec. Federal Specifications
19.	HP	Horsepower
20.	IEEE	Institute of Electrical and Electronics Engineers
21.	KW	Kilowatt
22.	MBH	One Thousand British Thermal Units per Hour
23.	MS or Mil.Spec.	Military Specifications
24.	MSS	Manufacturers Standardization Society
25.	NEC	National Electrical Code
26.	NEMA	National Electrical Manufacturers Association
27.	per	in accordance with
28.	PVC	Polyvinyl Chloride
29.	SMACNA	Sheet Metal and Air Conditioning Contractors National Association
30.	SP	Static Pressure
31.	UL	Underwriter's Laboratories

**NISQUALLY STATE PARK
NEW FULL SERVICE PARK – PHASE 2**

- 32. w.g. Water Gauge (inches of water)
- 33. WQA Water Quality Association
- 34. Additional abbreviations are as listed on the drawings or elsewhere in these specifications.

1.12 DEFINITIONS

- A. Finished Spaces: Spaces used for habitation or occupancy where rough surfaces are plastered, paneled, or otherwise treated to provide a pleasing appearance.
- B. Unfinished Spaces: Spaces used for storage or work areas where appearance is not a factor.
- C. Concealed Spaces: Spaces out of sight. For example, above ceilings; below floors; between double walls; furred-in areas; pipe and duct shafts; and similar spaces.
- D. Exposed: Open to view. For example, duct running through a room and not covered by other construction.
- E. Outside: Open to view up to 5 feet beyond the exterior side of walls, above the roof, and unexcavated or crawl spaces.
- F. Conditioned Space: An area, room or space normally occupied and being heated or cooled for human habitation by any equipment.

PART 2 - PRODUCTS

2.1 ACCEPTABLE MANUFACTURERS

- A. Any reference to the specifications or on the drawings to any article, device, product, material, fixture, form or type of construction by manufacturer, name, make, or catalog number shall be interpreted as establishing a standard of quality and shall not be construed as limiting competition.
- B. The manufacturer listed as Acceptable Manufacturers are approved for the items indicated without obtaining prior approval. Other manufacturers require prior approval.
- C. The listing of a manufacturer as an Acceptable Manufacturer does not necessarily mean that the products of that manufacturer are equal to those specified. The listing is only an indication of those manufacturers which may be capable of manufacturing, or have in the past manufactured, items equal to those specified, and is intended to aid the Contractor in identifying manufacturers.
- D. Products provided by Acceptable Manufacturers shall be equal to or superior to the specified manufacturer's item in function, appearance, and quality, and shall fulfill all requirements of the plans and specifications. The Engineer shall be the final judge as to whether an item meets these requirements or not. If a manufacturer is not certain that his product meets these requirements or not, then the manufacturer shall submit data as required to obtain the Design Consultant's approval.

**NISQUALLY STATE PARK
NEW FULL SERVICE PARK – PHASE 2**

- E. The approval of a manufacturer applies to the manufacturer only and does not relieve the Contractor from the responsibility of meeting all applicable requirements of the plans and specifications.
- F. Contractor shall be responsible for all costs to other trades and all revisions required to accommodate any products which are different than those specified or shown.
- G. In reviewing a manufacturer for acceptance, factors considered include the following: engineering data showing item's performance, proper local representation of manufacturer, likelihood of future manufacturer's local support of product, service availability, previous installation, previous use by Owner/Engineer and record, product quality, availability/quality of maintenance and operation data, capacity/performance compared to specified items, acoustics, items geometry/access utility needs, and similar concerns.
- H. If approval is received to use other than specified items, responsibility for specified capacities and insuring that items to be furnished will fit space available lies with this Division.
- I. If non-specified equipment is used and it will not fit job site conditions, this Division assumes responsibility for replacement with items named in Specification.

2.2 ACCESS DOORS

- A. This contractor shall be responsible for furnishing and installing flush mounted access doors in walls, ceiling and floors and chases where the following equipment is concealed and is not accessible through same.
 - 1. Valves (shut off)
 - 2. Dampers (balancing)
 - 3. Electric Heater Control Panels
 - 4. Fire Smoke Dampers
 - 5. HVAC Controls and Actuators
- B. Doors shall be UL listed 16 ga. cold rolled steel with concealed hinge, screwdriver operated lock and prime coated. Furnish suitable for area mounted.
- C. Approved Manufacturers:
 - 1. Milcor
 - 2. Karp
 - 3. Greenheck

2.3 EQUIPMENT AND PIPING IDENTIFICATION

- A. General: All ducting, valves, and HVAC equipment shall be marked. All markings in concealed accessible spaces shall be reviewed and verified by Architect/Engineer prior to being concealed.
- B. Valves shall be marked as follows:

**NISQUALLY STATE PARK
NEW FULL SERVICE PARK – PHASE 2**

1. Identification tags made of brass or aluminum, stamped with valve number and abbreviation of system served (HTG, PLBG, CW, HW, GAS, AC). Tags shall be installed on all valves except stops at plumbing fixtures. Tags shall be not less than 1-1/2 inch in diameter, markings shall be stamped and black filled, and lettering shall be minimum 1/4-inch high with numbers minimum 1/2-inch high. Tags shall be wired to each valve with No. 6 polished nickel-steel jack chain.
- C. All HVAC equipment which was scheduled on the Contract Drawings shall be marked with the name of the item; i.e., Heating Ventilating Unit No. 1, Exhaust Fan No. 2, Boiler No. 1 etc. The identification shall be the same as shown on the Contract Drawings. The marking shall be located on two different sides of the equipment so as to be easily read, with at least one marking visible to a person standing at floor level near the unit (assuming any necessary access to a concealed unit has been made). Lettering shall be a minimum of 2" high. Marking shall be with engraved phenolic labels, white letters on black background. Equipment marking is not required for; air outlets and inlets, plumbing fixtures.
- D. All HVAC control equipment shall be marked with phenolic labels. Equipment shall be marked to match the tags used in the programming of the control equipment.

PART 3 - EXECUTION

3.1 WORKMANSHIP

- A. This Contractor shall provide completed systems with a neat and finished appearance. If, in the judgment of the Engineer, any portion of the work has not been performed in a workmanlike manner or is left in a rough, unfinished state, this Contractor will be required to remove, reinstall or replace same and patch and paint surrounding surfaces in a manner acceptable to the Engineer, without increase in cost to the Owner.

3.2 CLOSEOUT SUBMITTALS

- A. Requirements: Final approval of mechanical installation will be recommended upon completion of the following:
1. Completion of all punchlist items
 2. Operation instruction period to Owner's satisfaction
 3. Permit Submittal
 4. Valve list posted
 5. Reproducible As-Built drawings delivered to Engineer
 6. Asbestos Free Statement
 7. Guarantees
 8. Equipment Manufacturer of all HVAC compressor units shall provide start-up logs.

3.3 FINAL INSPECTION

- A. Final Inspection:

**NISQUALLY STATE PARK
NEW FULL SERVICE PARK – PHASE 2**

1. Prior to acceptance of the HVAC work, the Contractor shall put all HVAC systems into operation for a period of not less than 5 working days so that they may be inspected by the Engineer and the Owner's representatives.
2. The time of the final inspection shall be mutually agreed to by the Owner, Engineer, and Contractor.
3. The Contractor shall furnish adequate staff to operate the HVAC systems during inspection.

3.4 OPERATION AND MAINTENANCE TRAINING

A. Upon completion of the work, and after all tests and final inspection of the work by the Authority(s) having jurisdiction, the Contractor shall demonstrate and instruct the Owner's designated operation and maintenance personnel in the operation and maintenance of the various HVAC systems. The Contractor shall arrange scheduled instruction periods with the Owner. The Contractor's representatives shall be Superintendents or Foremen knowledgeable in each system and Supplier's Representative when so specified.

B. Scheduled instruction periods shall be:

HVAC System Controls:	4 Hours
HVAC Equipment Maintenance:	4 Hours
Control / Maintenance Refresh:	4 hours, 6 months after Substantial Completion

C. Costs for time involved by Contractor shall be included in the bid.

3.5 INSTALLATION

- A. Install HVAC equipment to permit easy access for normal maintenance, and so that parts requiring periodic replacement or maintenance, (e.g., coils, heat exchanger bundles, sheaves, filters, meters, bearings, etc.) can be removed. Relocate items which interfere with access.
- B. Provide access doors in equipment, ducts, and walls/ceilings as required to allow for inspection and proper maintenance.
- C. If circumstances at a particular location make the accessible installation of an item difficult or inconvenient, the situation shall be discussed with the Engineer before installing the item in a poor access location.
- D. Belts, pulleys, couplings, projecting set screws, keys and other rotating parts which may pose a danger to personnel, shall be fully enclosed or guarded in accordance with OSHA regulations.
- E. Dissimilar Metals: Provide separations between all dissimilar metals. Where not specified in another way, use 10 mil black plastic tape wrapped at point of contact or plastic centering inserts.
- F. Provide offsets around all electrical panels (and similar electrical equipment) to maintain space clear above and below panel to structure and clearance of 3 feet directly in front of panel, except where indicated otherwise or required by NEC to be more. Such offsets are typically not shown on the drawings, but are required per this paragraph.

**NISQUALLY STATE PARK
NEW FULL SERVICE PARK – PHASE 2**

- G. Safety Protection: All ductwork, piping and related items installed by this Contractor that present a safety hazard (i.e., items installed at/near head height, items projecting into maintenance access paths, etc.) shall be covered (at hazardous area) with 3/4" thick elastomeric insulation and 2" wide reflective red/white striped self-sticking safety tape.
- H. Equipment Access: Access to equipment is of utmost importance. Contractor shall apply extra attention to the laying out of duct routings, and in coordinating all work. Poor access to equipment will not be accepted. Dashed areas at HVAC units indicate equipment access areas. These (and all other) access areas shall be clear of obstructions. The Division 23 contractor is responsible to coordinate and insure that all trades stay clear of access areas for any Division 23 furnished equipment.
- I. Insure that items to be furnished fit space available. Make necessary field measurements to ascertain space requirements including those for connections and furnish and install equipment of size and shape so final installation shall suit true intent and meaning of Contract Documents.

3.6 ADJUSTMENT AND CLEANING

- A. Properly lubricate equipment before Owner's acceptance.
- B. Clean exposed ductwork, equipment, and fixtures, remove debris from site. Repair damaged finishes and leave everything in working order.
- C. All work areas shall be left broom clean and free of debris. Sweep HVAC rooms at completion of work, and dispose of waste. Dispose of all existing waste in HVAC rooms in addition to waste generated by this work.

3.7 COMMISSIONING

- A. The Contractor has specific responsibilities relating to demonstrating the equipment and systems provided have been installed and function per the contract specifications. These responsibilities include, but are not limited to the following:
 - 1. Complete all equipment and system start-up and checkout procedures, and to insure the complete readiness of equipment and systems, prior to the start of the functional performance testing phase of the commissioning process.
 - 2. Functional test all HVAC systems in accordance with the Washington State Energy Code. Demonstrate system performance to the Engineer.
 - 3. Provide to the Owner a written commissioning process and the results of the functional performance testing.
- B. Owner shall not accept equipment and systems, and shall not make final payment, until all equipment and systems have been successfully commissioned and all specified requirements have been satisfied.

END OF SECTION

**NISQUALLY STATE PARK
NEW FULL SERVICE PARK – PHASE 2**

SECTION 230529 – HVAC HANGERS AND SUPPORTS

PART 1 - GENERAL

1.1 WORK INCLUDED

- A. Duct Hangers
- B. Equipment Hangers

1.2 QUALITY ASSURANCE

- A. Duct Hanger Standards: (MSS) Manufacturers Standardization Society Standards SP-58-1975, SP-89-1978, and SP-69-1976.
- B. All methods, materials and workmanship shall conform to the International Building Code (IBC) and International Mechanical Code (IMC), as amended and adopted by the authority having jurisdiction.

1.3 SUBMITTALS

- A. Submittals shall comply with Section 230500 General HVAC Requirements.
- B. Submit product data. Indicate where such items are to be used.
- C. Shop drawings are required for all equipment supports and fabricated supports or assemblies.

PART 2 - PRODUCTS

2.1 ACCEPTABLE MANUFACTURERS

- A. Hangers and Supports: Elcen, Grinnell, B-Line Systems, Unistrut, Michigan, Tolco.
- B. Anchors: Rawplug, Phillips, Hilti, Michigan.

2.2 GENERAL HANGERS AND SUPPORTS

- A. Hanger Rods: Threaded hot rolled steel, electro-galvanized or cadmium plated. Hanger rods shall be sized so that the total load (including pipe or duct, insulation, hangers, and fluid) does not exceed the following:

Nominal Rod Diameter	Maximum Load
1/4 Inch	240 Pounds
5/16 Inch	440 Pounds
3/8 Inch	610 Pounds

**NISQUALLY STATE PARK
NEW FULL SERVICE PARK – PHASE 2**

1/2 Inch	1130 Pounds
----------	-------------

- B. Hanger Straps: Galvanized steel. Straps shall be sized so that the total load does not exceed the following:

Strap Size	Maximum Load
1" x 22 Gauge	230 Pounds
1" x 20 Gauge	290 Pounds
1" x 18 Gauge	380 Pounds
1" x 16 Gauge	630 Pounds

- C. Beam Attachments: Shall be of the following type:

MSS Type	Elcen Figure No.	Grinnell Figure No.
21	33, 34	131
22	67	66
23	29A	87
28	95	292, 228
30	95	229

- D. Steel: Structural steel per ASTM A36.

- E. Wood: Shall be fire treated.

2.3 DUCT HANGERS AND SUPPORTS

- A. Hangers: As shown in SMACNA HVAC Duct Construction Standards.
- B. Vertical Duct Supports at Wall: 1-1/2" x 1/8" (minimum) strap or 1-1/2" x 1-1/2" x 1/8" (minimum) angle bracket and as shown in SMACNA HVAC Duct Construction Standards Figure 4-7.
- C. Hanger Attachments to Structure: As shown in SMACNA HVAC Duct Construction Standard Figures 4-1, 4-2, 4-3 to suit building construction and as allowed on structural drawings. Where C-clamps are provided, retainer clips shall be used. Friction beam clamps shall not be used.
- D. Hanger Attachments to Ducts: As shown in SMACNA HVAC Duct Construction Standards Figure 4-4.
- E. Rooftop Supports: Polyethylene platform with galvanized steel strut. Foam bottom for contact with roof membrane. Load rated for a minimum of 1000 Lbs. Provide galvanized steel straps sized as hanger straps, Erico Caddy Pyramid ST or approved.

PART 3 - EXECUTION

3.1 INSTALLATION – GENERAL

- A. Provide all necessary bolts, nuts, washers, turnbuckles, rod connectors and any other miscellaneous accessories required for the support and anchoring of all ducts, and HVAC equipment.

**NISQUALLY STATE PARK
NEW FULL SERVICE PARK – PHASE 2**

- B. Install steel or wood backing in walls (anchored to studs) as required to provide support for items hung from walls. Backing shall be of the same material as the studs or structure they are attached to.
- C. All welded steel support assemblies shall have a power wire brush and primer paint finish.
- D. Attach to building structure as shown on drawings.
- E. Maximum spans between piping supports may be significantly less than the maximum spans allowed herein due to structural limitations of allowable loads on hangers. The most restrictive criteria governs. Reference structural drawings.

3.2 INSTALLATION OF DUCT HANGERS AND SUPPORTS

- A. Provide anchors and supports for all ductwork.
- B. Rectangular Duct: Supports and hangers shall be of size and spacing as shown in SMACNA HVAC Duct Construction Standards for the appropriate class of duct. (Hangers maximum allowable loads shall not be as shown in SMACNA Tables but shall be as specified in these specifications.)
- C. Round Duct: Supports and hangers shall be of size and spacing as shown in SMACNA HVAC Duct Construction Standards for the appropriate class of duct.
- D. Maximum Hanger Spacing (provided duct gauge and reinforcement comply with SMACNA Standards for such spacing):

Duct Area	Maximum Spacing
Up to 4 sq. ft. (27" dia)	8 Feet
4.1 to 10 sq. ft. (28" to 42" dia)	6 Feet
10.1 sq. ft. and up (43" dia and up)	4 Feet

- E. Provide supports at each change in direction of duct. Locate hangers at inside and outside corners of elbows, or at each end of fitting, on each side.
- F. Provide additional supports at each side concentrated loads (such as modulating dampers, duct heaters, sound attenuators, etc.)
- G. Provide supports for exterior ductwork per SMACNA HVAC Duct Construction Standards or as detailed on the drawings.

3.3 INSTALLATION OF HVAC EQUIPMENT ANCHORS AND SUPPORTS

- A. Provide anchoring and supports for all HVAC equipment.
- B. Heating, Ventilating and Air Conditioning equipment where suspended from structure shall be supported per SMACNA HVAC Duct Construction Standards or as shown on the drawings.
- C. Equipment shall be supported and anchored in such a way so that no equipment vibration is transmitted to the building structure.

**NISQUALLY STATE PARK
NEW FULL SERVICE PARK – PHASE 2**

D. Added supports and bracing shall be provided per Section 230548.

END OF SECTION

**NISQUALLY STATE PARK
NEW FULL SERVICE PARK – PHASE 2**

SECTION 230548 – HVAC VIBRATION AND SEISMIC CONTROL

PART 1 - GENERAL

1.1 WORK INCLUDED

- A. Vibration Isolators
- B. Seismic Restraints

PART 2 - PRODUCTS

2.1 NEOPRENE ISOLATORS

- A. Suspension Isolators: Shall be double deflection neoprene type, with isolator encased in open steel bracket and minimum 3/8-inch deflection. Hanger rod shall be isolated from steel bracket with neoprene grommets. Mason Series HD, Amber Booth "BRD" or approved.

2.2 SPRING ISOLATORS

- A. General: The load carried by each isolator shall be carefully calculated and isolators selected so that the static deflection will be the same and the supported equipment will remain level. Isolators shall be so designed that the ends of the springs will remain parallel during and after deflection to operating height. At operating height, springs shall have additional travel to complete (solid) compression equal to at least 50 percent of the operating deflection. Suspension isolator springs shall have a static deflection (as shown on drawings) not less than 1-1/2", except that for units with components rotating at 1000 rpm and less, the static deflection shall be not less than 2 inches. Floor isolator springs shall have deflection of not less than 1 inch. All isolators shall provide at least 96% isolation efficiency. Note: Deflections other than these may be used where circumstances warrant and more optimum isolation results can be achieved.
- B. Suspension Type Spring Isolators: Shall consist of a rigid steel frame, a stable steel spring in the bottom part of the frame, and double deflection neoprene isolating pad at the top of the frame. Where supporting rods pass through the frame, a clearance of not less than on half rod diameter shall be provided all around the rod. Mason Series DNHS, Amber Booth "BSSR" or approved.

2.3 SEISMIC RESTRAINTS

- A. Materials: Steel shall be per STM A36; hangers and other devices shall be as shown in SMACNA Seismic Restraint Manual Guidelines for Mechanical Systems latest edition. Sheet metal used for bracing shall be no less than 16 gauge. Cable bracing may be used provided that opposed acting cables are provided on the items being braced to provide bracing equal to that provided by rigid angle bracing.

PART 3 - EXECUTION

**NISQUALLY STATE PARK
NEW FULL SERVICE PARK – PHASE 2**

3.1 INSTALLATION

A. Vibration Isolation:

1. Motorized equipment shall be suspended from spring vibration isolators either integral or external to the equipment.
2. Unless otherwise indicated, resilient mounts for motorized equipment shall be of the type and size to provide maximum ten percent transmissibility. Use unhooded, free-standing stable steel springs which are preferred over hooded spring assemblies. The horizontal stiffness of the spring shall be approximately equal to its vertical stiffness. The Spring deflection shall be selected based on the equipment power range (HP), speed range (RPM), and static deflection of the supporting structural floor. For large equipment such as fans the steel spring static deflection of the supporting structural floor. It is a specific recommendation that whenever a steel spring is used, two pads of ribbed waffle-pattern neoprene be used in series with the spring.
3. The design of vibration dampening shall consider lateral load as well as vertical load and be suitably snubbed against earthquake forces.
4. A list of isolators accompanied by certified transmissibility ratings for the required duty shall be submitted for each item of equipment.
5. Unless noted otherwise, all vibration isolating equipment shall be of the same make and shall be submitted as one group.
6. Special equipment, such as compressors shall be selected on an individual basis.

3.2 SEISMIC CONTROL

- A. Provide earthquake snubbers for all equipment that is supported on spring isolators and weighing over 300 lbs. including base. Provide minimum of four snubbers for equipment weighing less than 2,000 lbs., and eight snubbers for heavier equipment.
- B. Ductwork: Longitudinal and transverse bracing shall be required for all round ducts 28 inches in diameter and larger, for rectangular ducts 6 square feet and larger, and on all duct systems used for life safety and smoke control installed in either the horizontal or vertical position. Bracing shall be applied as follows:
 1. Transverse bracing shall occur at maximum intervals of 30 feet, at each duct turn and at the end of a duct run.
 2. Longitudinal bracing shall occur at maximum intervals of 60 feet. Transverse bracing for one duct section may also act as longitudinal bracing for a duct section connected perpendicular to it, if bracing is installed within 4 feet of the intersection and sized and installed on the larger duct.
 3. Groups of ducts may be combined in a larger size frame using overall dimensions and maximum weight of ducts. At least two sides of each duct must be connected to the angles of the brace.
 4. Walls, including non-bearing fixed partitions which have ducts running through them, may replace a transverse brace.
 5. Bracing may be omitted when the top of the duct is suspended 12 inches or less from the supporting structural members and on roof top ductwork.

END OF SECTION

**NISQUALLY STATE PARK
NEW FULL SERVICE PARK – PHASE 2**

SECTION 230593 – AIR AND HYDRONIC BALANCING

PART 1 - GENERAL

1.1 WORK INCLUDED

- A. Air Balancing.
- B. Hydronic System Balancing
- C. Report.

1.2 REFERENCES

- A. Associated Air Balance Council: National Standards for Field Measurements and Instrumentation.
- B. ASHRAE: 2001 Handbook of Fundamentals.
- C. American Conference of Governmental Hygienists: Industrial Ventilation, A Manual of Recommended Practice, 20th Edition.

1.3 GENERAL REQUIREMENTS

- A. General: The air and hydronic balancing shall be done by a company which specializes in this type of work and is totally independent and separate from the company or contractor which has installed the systems to be balanced.
- B. Prior to beginning balancing, submit the name of the company the Contractor proposes to have do the balancing to the Architect/Engineer for approval.
- C. Engineer: The final report of this work shall be stamped by a licensed Mechanical Engineer and accompanied by a statement from this engineer that the work complies with the Associated Air Balance Council Standards and these project specifications.
- D. Notify the Architect in writing of all problems or discrepancies between actual conditions and what design documents show as work proceeds.
- E. The Balancer shall be directly responsible to the Engineer and shall perform this work as directed by the Engineer.

**NISQUALLY STATE PARK
NEW FULL SERVICE PARK – PHASE 2**

PART 2 - PRODUCTS

2.1 GENERAL INSTRUMENTATION

- A. Balancing equipment shall comply with Associated Air Balance Council recommendations for field measurement instrumentation.
- B. All measuring instruments shall be accurately calibrated and maintained in good working order. Calibration dates and certifications shall be available at Engineer's request.
- C. Instruments shall be capable of:
 - 1. Air velocity instruments, direct reading in feet per minute with 2% accuracy.
 - 2. Static pressure instruments, direct reading in inches water gauge with 2% accuracy.
 - 3. Tachometers, direct reading in revolutions per minute with 1/2% accuracy; or revolution counter accurate with 2 counts per 1,000.
 - 4. Thermometers, direct reading in degrees Fahrenheit with 1/10 of a degree accuracy.
 - 5. Pressure gauges, direct reading in feet of water or psig with 1/2% accuracy.
 - 6. Water flow instruments, direct reading in feet of water or psig with 1/2% accuracy suitable for readout of balancing valve provided.

PART 3 - EXECUTION

3.1 GENERAL

- A. All air systems shall be completely balanced and adjusted to provide the air and flow rates indicated, and to produce an even heating and cooling effect and control response.
- B. Consult and coordinate with the Section 230900 (HVAC Controls) Contractor for the adjustment of all control devices to allow for proper system operation.
- C. Make final adjustments for flow rates in order to optimize each space's comfort, including such considerations as temperature, drafts, noise, pressurization, and air changes. Where variances are made from design values, state reasons in report (e.g., "too much noise", etc.). All such variances are subject to approval by the Architect/Engineer.
- D. All measurements and adjustments shall be in accordance with the Associated Air Balance Council National Standards.

3.2 AIR BALANCING

- A. Pre-check of System: Prior to beginning balancing, perform, as a minimum, the following:
 - 1. Verify that clean filters have been installed, that system is free from debris, and that all inlets/outlets are not obstructed.
 - 2. Check all fans and equipment to verify that proper start-up and system preparation has been done by the installing contractor.

**NISQUALLY STATE PARK
NEW FULL SERVICE PARK – PHASE 2**

3. Check all door/window and similar building opening status to insure building is ready and proper pressurization can be obtained.
 4. Open all dampers to full flow position, check positions and operation of all motorized dampers to allow full system flows.
 5. Review controls and sequences of operation.
- B. Tolerances: All air flow rates (supply, return, and exhaust) shall be adjusted to within plus 5 percent and minus 5 percent of the values shown in the contract documents, except that relative space-to-space pressure relationships shall always be maintained (e.g., restrooms shall be negative relative to other areas, general offices shall be positive, etc.).
- C. All diffusers, grilles, and registers shall be adjusted to minimize drafts and to eliminate objectionable noise.
- D. Air balancing shall be done with new, clean air filters installed. Adjust air deliveries so that design quantities will be obtained when filters are half dirty. This condition shall be simulated by covering a portion of the filter area.
- E. Adjust fan speeds and fan drives as required to produce design air quantities.
- F. Measurements and adjustments of the air handling and distribution equipment shall be executed in a manner consistent with the manufacturer's recommendations.
- G. At completion of balancing, mark the final position of all balancing dampers and record all data.
- H. Air flow measurements in main ducts shall be made with a duct traverse using a pitot tube and micromanometer. Summation of air terminal outlets and inlets is not sufficient. Quantity of duct leakage shall be indicated.
- I. Duct traverses in rectangular duct shall measure the center of equal areas in the air flow stream, with centers not more than 6 inches apart. Round duct traverses shall measure at least 20 locations, with locations being the centers of equal annular area. Reference the ACGIH Industrial Ventilation Manual, Chapter 9, Testing of Ventilation Systems.
- J. Balance each branch run so that there is at least one wide open run; balance branches relative to one another so that at least one branch damper is wide open.
- K. Requirements for All Air Handling Systems: Data to be measured/recorded and provided in report:
1. Floor plans clearly showing and identifying all diffusers, grilles, O.A. louvers, ducts and all other items where air flow rates were measured.
 2. Identify manufacturer, model number, size, and type of all air inlets/outlets.
 3. Initial, trial, and final air flow measurements for all diffusers, grilles, O.A. louvers, ducts, and all other items where air flow rates were measured.
 4. Design air flow rates and percentage final air flow rates are of design values
 5. The connected voltage and corresponding nameplate full load amps, and the initial and final amperages of all fan motors.
 6. Initial and final RPMs of all fans.
 7. Static pressures on inlet and outlet of all units.
 8. Fan initial and final CFMs.

**NISQUALLY STATE PARK
NEW FULL SERVICE PARK – PHASE 2**

9. Outdoor air CFMs (record minimum and maximum values).
10. Data required for all equipment which are part of balanced systems:
 - a. Equipment name and number (as used on drawings).
 - b. Service.
 - c. Equipment manufacturer and model numbers.
 - d. Sheave and belt sizes (where applicable).
 - e. Filters sizes and quantities (where applicable).
 - f. Motor manufacturer and complete nameplate data.
 - g. Design operating conditions.
 - h. Actual operating conditions (flows, pressure drops, rpm, etc.).

3.3 HYDRONIC SYSTEM BALANCING

- A. Pre-check of System: Prior to beginning balancing, perform, as a minimum, the following:
 1. Verify that all strainers have been cleaned.
 2. Examine fluid in system to verify treatment and cleaning.
 3. Check for proper rotation and operation of all pumps.
 4. Verify that expansion tanks are not air bound and properly charged and that system is full of fluid.
 5. Verify that all air vents at high points in the fluid system are properly installed and are operating freely. Remove all air from the circulating system.
 6. Open all valves to full flow position, including coil and heater stop valves, close any bypass valves, and open fully balancing valves. Set temperature controls so that automatic valves are open to full flow.
 7. Check operation of automatic bypass valves and similar flow/pressure controls.
 8. Check and set operating temperature of equipment to design requirements when balancing by temperature drop.
 9. Check all equipment for proper start-up and system preparation by installing contractor.
 10. Review controls and sequences of operation.
- B. Tolerances: All water flow rates shall be adjusted to within plus 5 percent and minus 5 percent of the values shown in the contract documents.
- C. Adjust control valve bypass valves so that pressure drop is the same for full flow-through bypass valve as for full flow-through control valve and controlled equipment.
- D. Set all controls and valves as required to maintain design water and/or air temperatures as shown on the drawings.
- E. All adjustments and measurements shall be made in strict accordance with the manufacturer's instructions.
- F. Upon completion of flow readings and adjustments, mark all settings and record all data. Permanently mark balanced position of all balancing valves. Stamp indicator plate of balancing valves without memory stop.
- G. Requirements for All Hydronic Systems: Data to be measured/recorded and provided in report:

**NISQUALLY STATE PARK
NEW FULL SERVICE PARK – PHASE 2**

1. Floor plans or schematics showing and identifying all valves, coils, pumps and other items where temperatures, pressure drops, or water flow rates were measured.
2. Identify manufacturer, model number, size and type for all balancing devices.
3. Initial, trial, and final water flow measurements (pressure drops, temperatures, and GPMs) for all items where measurements were made.
4. Design water flow rates, and percentage final water flows are of design values.
5. The connected voltage and corresponding nameplate full load amps, and the initial and final amperages of all pump motors.
6. Pump operating suction and discharge pressures and final total developed head.
7. Pump initial and final GPMs.
8. Entering and leaving fluid temperatures at coils and major equipment.
9. GPM flow of each coil and major equipment.
10. Pressure drop across each coil and major equipment.
11. Pressure drop across bypass valve.
12. Final position of all valves (percent open or setting position on valve).
13. Data required for all equipment which are part of balanced systems:
 - a. Equipment name and number (as used on drawings).
 - b. Service.
 - c. Equipment manufacturers and model number.
 - d. Equipment capacities.
 - e. Motor manufacturer and complete nameplate data.
 - f. Design operating conditions.
 - g. Actual operating conditions (flows, pressure drops, etc.).

3.4 BALANCING REPORT

- A. General: A balancing report shall be submitted as specified herein, documenting all balancing procedures and measurements.
- B. Preliminary Report: Two preliminary review copies of the balancing report shall be submitted to the Architect/Engineer when the balancing work is 90% complete (or as near 90% complete as possible due to uncompleted work of other trades). In addition to containing all the information required of the final report, the preliminary report shall contain a list of all the work required of other trades in order to allow the balancing work to be completed. The Architect/Engineer will review the preliminary report and inform the Contractor of any additional items or revisions required for the final report. Preliminary reports may be omitted where the Architect/Engineer grants approval.
- C. Final Report: Shall be included in the Operation and Maintenance Manual. Submit reports to Contractor for inclusion in Manuals (or, when manuals have been already sent to Engineer, send report to Engineer who will insert report into Manual). Provide number of reports as required to match quantity of O&M Manuals, but in no case less than five (5).
- D. Report Organization: The report shall be divided into logical sections consistent with the building or system layout (i.e. by floors, building wings, air handling units, or other convenient way). Tabulate data separately for each system. Describe balancing method used for each system.
- E. Format: 8 1/2" x 11" size, neat, clean copies, drawings accordion folded. Report shall be typed, shall have a title page, table of contents, and divider sheets with identification tabs between

**NISQUALLY STATE PARK
NEW FULL SERVICE PARK – PHASE 2**

sections. Information shall be placed in a three-ring notebook, with the front cover labeled with the name of the Job, Owner, Architect/Engineer, Balancing Contractor, and Report Date.

- F. General Balancing Information Required:
1. At the beginning of the report, include a summary of problems encountered, deviations from design, remaining problems, recommendations, and comments.
 2. List of instruments used in making the measurements and instrument calibration data.
 3. Names of personnel performing measurements.
 4. Explanation of procedures used in making measurements and balancing each system.
 5. List of all correction factors used for all diffusers, grilles, valves, venturi meters, and any other correction factors used.
 6. Areas where difficulties were encountered in obtaining design flow rates, or where unstable operating conditions may exist.
 7. Note any parts of the system where objectionable drafts or noises may be present and efforts made to eliminate same and why they may still be present.
 8. Note where variances from design values occur; explain why.
- G. Air Balancing Information: All previously cited required measurement/recorded data, any additional recorded data, and observations.
- H. Hydronic Balancing Information: All previously cited required measurement/recorded data, any additional recorded data, and observations.

END OF SECTION

**NISQUALLY STATE PARK
NEW FULL SERVICE PARK – PHASE 2**

SECTION 230700 – HVAC INSULATION

PART 1 - GENERAL

1.1 WORK INCLUDED

- A. Duct Insulation.
- B. Equipment and Specialties Insulation.

1.2 DEFINITIONS

- A. "Run-out" means "piping not more than 12 feet long that runs to an individual fixture or unit."
- B. "Conditioned Areas" means "areas that are directly and intentionally supplied by heated or cooled air".

1.3 QUALITY ASSURANCE

- A. All insulation shall have a fire hazard rating not to exceed 25 for flame spread and 50 for smoke development, as tested by ASTM E 84, NFPA 255, and UL 723.

1.4 SUBMITTALS

- A. All submittals shall comply with Section 230500.
- B. Provide product data on all insulation materials to be used. Indicate thicknesses to be used.

1.5 GENERAL REQUIREMENTS

- A. Code Compliance: Contractor shall insulate all systems with the materials and thicknesses as specified herein, but in no case shall the insulation be less than that required by the Washington State Energy Code (latest edition and amendments) or Energy Code enforced by the authority having jurisdiction. Contractor shall, in addition to insulating those systems/items specified herein, provide insulation where required by Code.
- B. Insulation at Hangers: Insulation shall be continuous through hangers on all insulated systems (except ductwork.) Inserts at hangers are specified and are considered as part of the hanger and support system. Inserts are required to be installed at the time of pipe installation and are intended to be installed by the Contractor installing the pipe hangers/supports.

PART 2 - PRODUCTS

**NISQUALLY STATE PARK
NEW FULL SERVICE PARK – PHASE 2**

2.1 ACCEPTABLE MANUFACTURERS

- A. Products shall comply with Section 230500 General HVAC Requirements, Acceptable Manufacturers.
- B. Insulation: Manville, Armstrong, Owens Corning, CSG, Knauf, Rubatex, Pittsburgh Corning, Imcoa, Halstead.
- C. Accessories: Same as for insulation and Duro Dyne, Gustin Bacon, Childers, RPR, Tee Cee, J. P. Stevens, Buckaroos, Johnson.

2.2 DUCT INSULATION

- A. Fiberglass Insulation: 1.0 lb. per cubic foot minimum density; thermal conductivity no greater than 0.25 Btu-in/hr-sq. ft.-deg. F. at 75 degrees F with factory applied jacket as specified below.
- B. Fiberglass Insulation Jacket: Vapor proof jacket, consisting of aluminum foil cover with open mesh fiberglass, reinforcement, laminated to UL rated Kraft, vapor transmission rate shall not exceed 0.05 perms.
- C. Adhesive: Fire retardant, Duro Dyne type FPG or equal.
- D. Clips: Cement on or welded on pins impaled through glass fiber, with surface washers.
- E. Insulation Thickness:
 - 1. Supply Air Ductwork Within Building Space with Conditioned Air on Each Side of Space (e.g., mid-floor ceiling spaces, exposed duct): 1.0 inch thick.
 - 2. Supply Air Ductwork Within Building Space Without Conditioned Air on Each Side of Space (e.g., attic, crawl space, area between ceiling and roof): 2.0 inch thick.
 - 3. Supply Air Ductwork on Roof or Exterior of Building: Interior duct lining used--specified in Section 233100.
 - 4. Return Air Ductwork Within Building Space With Conditioned Air on Each Side of Space (e.g., mid-floor ceiling plenums): No insulation required.
 - 5. Return Air Ductwork Within Building Space Without Conditioned Air on Each Side of Space (e.g., attic, crawl space): 1.0 inch thick.
 - 6. Outdoor Air Intake Ductwork Within Building Space With Conditioned Air on Each Side of Space (e.g., ceiling plenums, exposed duct): 2.0 inch thick.
 - 7. Outdoor Air Intake Ductwork Within Building Space Without Conditioned Air on Each Side of Space (e.g., attic, crawl space): 1.0 inch thick.
 - 8. Exhaust Air Ductwork: 2.0 inch thick from point of exhaust airstream backdraft damper to outdoor termination.
 - 9. Alternative Insulation Thickness: Insulation thicknesses indicated are based on the thermal conductivities specified. Contractor at his option may use other insulation thicknesses for insulation with different thermal conductivities provided that the overall heat transfer coefficient is the same as if the specified insulation had been used. Submit calculations showing insulation equivalency for approval.

2.3 EQUIPMENT AND SPECIALTIES INSULATION

**NISQUALLY STATE PARK
NEW FULL SERVICE PARK – PHASE 2**

- A. Equipment: Insulation shall be same material as that specified for the HVAC system the equipment is installed in. Insulation thickness shall be 1.5 inches.
- B. Valves: All valves installed in insulated HVAC systems shall be insulated. Insulation material and thickness shall be same as that specified for the HVAC system the valve is installed in. Insulation shall be removable type on all control valves.
- C. Removable Insulation: Shall provide thermal insulating properties equivalent to that which is provided for HVAC system. Shall consist of 0.25-inch J. P. Stevens "Insulbatte" with glass cloth jacket, 4.0-inch Owens-Corning thermal insulating wool, Type II, fastened with No. 304 stainless steel hooks tied with 0.040-inch soft solid annealed copper wire. Where metal jacketing is required, provide with removable enclosures, of same material as metal jacketing, configured to suit items covered.

PART 3 - EXECUTION

3.1 GENERAL

- A. Equipment and Floor Protection: Cover existing equipment and finished floors to protect such items from insulation fiber and dust. Keep all such existing areas in a "broom clean" condition at the end of each day. Take precautions in these areas to prevent glass fiber and insulation dust from entering existing ventilating systems.
- B. Glass Fiber Insulation:
 - 1. Finish all insulation ends, no raw edges allowed.
 - 2. Joints: Tightly butt adjacent insulation sections together without any voids. Provide overlap of jacket material over all circumferential joints.
- C. Insulation Thickness: See "Part 2 - Products" for insulation thicknesses.
- D. Items To Be Insulated: Provide insulation on all ductwork, and all items installed in these duct systems, all energy conveying, all energy storage, and all energy consuming devices specified as part of Division 23, except where such insulation has been specifically excluded.
- E. Items Excluded From Being Insulated:
 - 1. Electric motors.
 - 2. Factory insulated or factory lined HVAC units.
 - 3. Fans.
 - 4. Internally lined ductwork.

3.2 DUCT INSULATION INSTALLATION

- A. Insulate all ducts with specified thickness.
- B. Insulation shall be firmly butted at all joints with a maximum allowable compression of 25%. All seams shall overlap a minimum of 2 inches and be finished with appropriate pressure sensitive

**NISQUALLY STATE PARK
NEW FULL SERVICE PARK – PHASE 2**

tape or glass fabric and vapor retardant mastic. Pressure sensitive tapes and glass cloth shall be a minimum 3 inches wide.

- C. For rectangular ducts over 18 inches wide, duct wrap shall be additionally secured to the bottom of the ductwork with mechanical fasteners on 18 inch centers to reduce sagging. Washers shall be applied without compressing the insulation. All seams, joints, penetrations, and damage to the facing shall be sealed with vapor retardant mastic.
- D. Inside duct lining shall be as specified in Section 233100 - Ductwork.
- E. All HVAC supply and outdoor air ducts shall be covered with glass fiber insulation. Where duct lining is used, the insulating properties of the lining may be credited toward meeting the R value specified for insulation.

3.3 EQUIPMENT AND SPECIALTIES INSTALLATION

- A. All equipment where access is required shall have insulation installed so that it can be easily removed and reinstalled without requiring new insulation. Items requiring such removable insulation include, but are not limited to, the following:
 - 1. Control Valves.
 - 2. Strainers.
 - 3. Balancing Devices.
 - 4. Pressure/Temperature/Flow Measuring Devices.
- B. Specialties Requiring Insulation: All items connected in an insulated HVAC system shall be insulated, except the following:
 - 1. Factory Insulated Items.
 - 2. Diffusers & Grilles.

END OF SECTION

**NISQUALLY STATE PARK
NEW FULL SERVICE PARK – PHASE 2**

SECTION 230900 – HVAC CONTROLS

PART 1 - GENERAL

1.1 WORK INCLUDED

- A. Control System Design.
- B. Complete system of automatic heating, ventilating, and air conditioning controls.
- C. Control devices, components, and wiring.
- D. Testing and adjustment.
- E. Operator Training.

1.2 DEFINITIONS

- A. "Conventional control components" means "control valves, dampers, actuators, wiring, air compressors, and other control devices that are not microprocessor based."

1.3 SUBMITTALS

- A. Shall comply with Section 230500 General HVAC Requirements.
- B. Submit a complete list of equipment to be furnished, including product information for each item on the material list. Submit samples of wall sensor and bypass switch.
- C. Submit a complete set of shop drawings prior to installation containing the following information: interconnect drawings showing all wiring and control connections, control panel locations, all control device locations, arrangement of devices in panels, sequence of operation for all equipment, ladder diagrams showing switching functions of system and programs, logical outline of intended programs, building floor plans with all proposed thermostatic and other control device locations shown.
- D. Submit list of proposed component labeling.
- E. Record Drawings: See Section 230500 General HVAC Requirements.
- F. Operation and Maintenance Manuals: See Section 230500 General HVAC Requirements. In addition to the information required by that Section, provide (for inclusion in mechanical O&M Manual) the following:
 - 1. A list of spare parts and prices recommended for purchase by the Owner.
 - 2. System description and complete sequence of operation.
 - 3. Reduced size (11" x 17") copies of record drawings.

**NISQUALLY STATE PARK
NEW FULL SERVICE PARK – PHASE 2**

4. Input/Output (I/O) summary forms for the system listing all connected analog and binary input and output functions and the number types of all points.
5. Description of unique devices/controls/programs specific to this system.

G. Programmers Manuals: Provide manufacturer's programming manuals to Owner.

1.4 GENERAL REQUIREMENTS

- A. The entire control system shall be installed by skilled electricians and mechanics, all of whom are properly trained and qualified for the work they perform.
- B. One single Contractor shall be responsible to design, furnish and install the complete building controls. Any subcontracted installation work shall be done by Contractors experienced and qualified in the work they perform subject to approval by the Engineer. Submit names(s) of proposed subcontractor(s) who will perform control work and extent of the work they will perform.

1.5 SPARE PARTS AND SPECIAL TOOLS

- A. Special Tools: Provide any special tools needed per Section 230500 General HVAC Requirements.
- B. Spare Parts: Provide one spare room temperature sensor of the type installed.

1.6 WARRANTY AND SERVICE

- A. Warranty: After completion of the installation of the control system and acceptance by the Owner, the system shall be warranted as free against defects in manufacturing, programming, workmanship and materials for a period of one year from date of acceptance. In addition, the system shall be warranted to provide the sequence of operation and basic features specified, with the accuracy and flexibility also specified. The system shall be repaired or replaced, including materials and labor, if in owner's reasonable opinion, system is other than as warranted. Preventive and emergency maintenance shall be included.
- B. End of Warranty Service: At the end of the warranty period, the Contractor shall provide a re-check of the entire system operation, including calibration testing of a sample number of components and providing any necessary control adjustments for proper system operation. Such work shall be for a minimum of 4 man-hours.

PART 2 - PRODUCTS

2.1 ACCEPTABLE MANUFACTURERS

- A. Products shall comply with Section 230500 General HVAC Requirements, Acceptable Manufacturers.
- B. Programmable Thermostats: Factory Supplied Thermostats.

**NISQUALLY STATE PARK
NEW FULL SERVICE PARK – PHASE 2**

C. Conventional Control Components and Accessories:

1. Products shall comply with Section 230500 General HVAC Requirements, Acceptable Manufacturers.
2. Control Components: Seibe, Honeywell, Johnson Controls.
3. Control Accessories: Idec, Hoffman, McDonnell, Tridelta, Edwards, Mamac, APC, Barksdale, Mark-Time, and manufacturers listed for Control Components.
4. Control Components factory supplied with equipment specified are acceptable if capable of meeting performance and operation requirements.

2.2 BASIC SYSTEM

- A. The system shall be programmable thermostats with added features for door switches, timeclock functions, occupancy sensors, and similar functions.

2.3 PROGRAMMABLE THERMOSTATS

- A. Thermostats shall be wall-mounted thermostats supplied by the equipment manufacturer. Thermostats have a programmable occupancy schedule, temperature display, and adjustable temperature setting.

2.4 ACTUATORS

- A. Actuators shall be heavy duty reversible type, with driving motor and gear train and sealed in die cast case. Proportional actuators shall have a built-in electro-mechanical system to provide for positive repeatability of position, regardless of changes in output load. Belimo only.
- B. Actuator shall be proportional or two position type, as required for application. Actuator power and torque shall be sufficient to match dampers or valves being controlled and allow proper damper and valve operation against system pressures liable to be encountered. Actuator shall be capable of driving dampers from full closed to full open in less than 15 seconds.
- C. Units shall be complete with all linkages, brackets, and hardware required for mounting and to allow for the proper control of the regulated damper or valve.
- D. Actuator shall spring return upon power interruption to allow controlled devices to "fail safe" in open or closed position as dictated by freeze, fire or temperature protection requirements.

2.5 ACCESSORIES

- A. Wiring and Conduit: Shall comply with Division 26 specifications. Wiring that performs code required life safety shutdown of equipment or fire alarm interface shall comply with NFPA and local codes for fire alarm system wiring.
- B. Control Cabinet: Wall mounted, NEMA Type 1 construction, UL listed minimum 14 gauge sheet metal, hinged front door with latch. Size as required to house controls. Controls/devices shall be logically assembled in cabinet, with all devices and cabinet labeled.

**NISQUALLY STATE PARK
NEW FULL SERVICE PARK – PHASE 2**

- C. Relays: See paragraph "Contactors".
- D. Contactors: Shall be the single coil electrically operated, mechanically held type. Positive locking shall be obtained without the use of hooks, latches, or semi-permanent magnets. Contacts shall be doubled break silver to silver type protected by arching contact where necessary. Number of contacts and rating shall be selected for the application intended. Operating and release times shall be 100 milliseconds or less. Contractors shall be equipped with coil transient suppression devices to limit transients to 150% of rated coil voltage.
- E. Miscellaneous Sensors/Transmitters/Switches/Transformers: Shall be manufacturer's standard, designed for application in commercial building HVAC control systems, compatible with other components so as to provide sequence of operation specified.

2.6 SWITCHES

- A. Air Flow Switches: General Purpose utilizing differential air pressure, SPDT snap-acting contacts, adjustable 0.1in. W.C. to 2.0 in. (minimum), neoprene diaphragm, all aluminum construction.
- B. Damper End Switches: Shall be momentary type limit switches for monitoring the motion of the damper at a prescribed arc of rotation. The switch shall be hermetically sealed mercury contacts that operate by way of a trip lever. The switch shall be mounted on the exterior of the duct so that the trip lever is aligned with the damper vane. Mechanical adjustments in the switch case shall permit the proper lever action for tripping the mercury switch contacts. The switch shall have a SPDT contact arrangement that exceeds the load requirements for both voltage and current.
- C. Pressure to Electric Switches (PE): Shall sense a gradual control air pressure change and provide a snap action SPDT contact output. The setpoint shall be adjustable from 3 to 25 PSIG with a fixed differential of 2 PSI. The PE switch shall be suitable for both line and low voltage control applications and be listed by UL for electrical safety.
- D. Bypass Switch: Shall be momentary contact type push button. Install in standard wall box with stainless steel cover.
- E. Wall On/Off Switch: Standard wall box type switch, single pole, with illuminated switch for when controlled item is on. Provide with stainless steel wall plate, labeled as to function. Leviton or approved.
- F. 3-Position Wall Switch: Standard wall box type switch, with center off position, pole and throw to suit application. Provide with >036 stainless steel wall plate engraved as to function and each switch position. Arrow-Hart No. 4356, 4357, 4361, 4371, or equal.
- G. Electronic Count Down Timer Switch: 120V SPST switch rated for ½ HP motor. Switch has choice of 5, 15, 30, 45, 60, or 120 minutes. Install in standard wall box with stainless steel cover. Marktime 42802 or approved.

PART 3 - EXECUTION

**NISQUALLY STATE PARK
NEW FULL SERVICE PARK – PHASE 2**

3.1 GENERAL

- A. Provide complete system with sequences of operation and Energy Code requirements as indicated on drawings.
- B. Time Control: Central time clock shall provide occupied/unoccupied mode switching for all items indicated as having time clock control.
- C. Warm-up Control: Central optimum-start controls shall provide warm-up switching for all items indicated as having a warm-up cycle.
- D. Provide all actuators and other devices for all equipment where such actuators or related devices are not specified as being furnished by the equipment manufacturer.
- E. Various thermostats are not shown on the drawings but are required per the sequence of operation specified. Coordinate with Engineer for location of all such thermostats prior to installing.
- F. Provide all motor rated relays and/or motor starters required to allow for automatic control as specified herein, where such devices have not been provided by others.

3.2 INSTALLATION

- A. Provide all computer software and hardware, operator input/output devices, sensors, relays, switches, dampers, actuators, conduit, tubing, wiring, motor starters and all other devices required to provide a complete integrated system with the sequence of operation and basic system features as specified.
- B. Room thermostats shall be mounted 48" above finished floor unless indicated otherwise. Thermostats shall connect to the HVAC or fan unit serving the space the thermostat is located in, unless indicated otherwise. Not all thermostats are shown on the drawings and those shown are preliminary only. Contractor shall indicate all final thermostat locations on submittal drawings. Contractor is responsible to coordinate locations to avoid chalkboards, tackboards, and other interferences.
- C. It shall be the responsibility of this Contractor to provide power for all damper motors, time clocks, and other control devices requiring power. Coordinate with the Division 26 Contractor to arrange for necessary power circuits. Circuits have been made available in various electrical panels for this purpose (see electrical drawings/panel schedules).
- D. Provide all electrical wiring and devices in accordance with applicable National, State and local codes and Division 26 requirements. All wiring shall be installed in conduit and in accordance with electrical section of these specifications, except that low voltage wiring within the ceiling plenum spaces and in mechanical platform area may be ran without conduit provided that plenum rated cable is used. Install all conduit and wiring parallel to building lines.
- E. Component Labeling: All control components, except regular room thermostats, shall be equipped with name plates to identify each control component. Components in finished rooms shall be labeled as to generic item controlled for better user understanding; other devices shall be labeled with the same designation which appears on the Control Diagrams. Contractor shall submit list of proposed labeling prior to installing.

**NISQUALLY STATE PARK
NEW FULL SERVICE PARK – PHASE 2**

- F. Thermostat setpoints (all adjustable) shall be as follows unless indicated otherwise:
1. Occupied Heating 72 degrees F
 2. Unoccupied Heating 70 degrees F
- G. Motor Starters: Control contractor shall provide all necessary motor starters and motor starting relays to allow proper control of the items listed herein where such starters/relays have not been specifically shown on the electrical drawings. Such starters/relays provided shall comply with the applicable Division 26 specifications, NEC, and governing code requirements. It is the general intent of the project documents that motor starting devices for motors 3/4 HP and smaller be provided by the Control Contractor, except where specifically shown.

END OF SECTION

**NISQUALLY STATE PARK
NEW FULL SERVICE PARK – PHASE 2**

SECTION 233100 – DUCTWORK

PART 1 - GENERAL

1.1 WORK INCLUDED

- A. Environmental Ductwork Systems.
- B. Acoustical Duct Lining.
- C. Duct Cleaning and Testing.
- D. Duct Shop Drawings.

1.2 DEFINITIONS

- A. Duct Sizes: All duct dimensions shown are inside clear dimensions. Where inside duct lining is specified or indicated, duct dimensions are to the inside face of lining.
- B. Low Pressure System: Velocities less than 2,000 fpm and static pressure in duct 2 inches w.g. or less.
- C. Gauges: Steel sheet and wire are U.S. Standard Gauge; aluminum sheet is Brown and Sharpe Gauge.

1.3 QUALITY ASSURANCE

- A. Fabricate and install ductwork in accordance with SMACNA duct construction publications and ASHRAE handbooks.
- B. Materials and installations shall comply with NFPA 90A, NFPA 90B, and the IMC.

1.4 SUBMITTALS

- A. Submittals shall comply with Section 230500 General HVAC Requirements.
- B. Submit shop drawings for all HVAC ductwork which is to be installed differently than as shown on the drawings.

1.5 DUCT PRESSURE CLASS

- A. All ductwork shall be constructed to the static pressure indicated by the fan which serves the ductwork, or to 1-inch (plus or minus as appropriate), whichever is higher.

**NISQUALLY STATE PARK
NEW FULL SERVICE PARK – PHASE 2**

1.6 REFERENCES

- A. SMACNA HVAC Duct Construction Standards, Current Edition.
- B. SMACNA Duct Liner Application Standard, Current Edition.
- C. NFPA 90A: Standard for the Installation of Air Conditioning and Ventilating Systems.
- D. NFPA 90B: Standard for the Installation of Warm Air Heating and Air Conditioning Systems.
- E. IMC: International Mechanical Code.

PART 2 - PRODUCTS

2.1 ACCEPTABLE MANUFACTURERS

- A. Products shall comply with Section 230500 General HVAC Requirements.
- B. Sheet Metal: All domestic manufacturers.
- C. Spin in Fittings: General Environment Corp., Clevepak Corp.
- D. Duct Sealant and Tape: Durkee Atwood, Hardcast, Duro Dyne, Benjamin Foster, Products Research, Chemical Corp, and Ductwork.

2.2 GENERAL MATERIALS

- A. Ducts: Construct of galvanized sheet steel, suitable for lock forming without flaking or cracking, conforming to ASTM A527, having a zinc coating of 1.25 ounces total per square foot for both sides of a sheet, corresponding to coating designation G90 per ASTM A525.
- B. Fasteners: Use rivets and bolts throughout; sheet metal screws are acceptable on low pressure ductwork only.
- C. Spin-in Fittings: Factory fabricated of galvanized steel, bell-shaped, with die-formed mounting groove and damper. Provide 45 degree extractor when the spin-in fitting is installed in a duct which has a width of 12 inches or more. General Environmental Model SM-1D or SM-1 DEL.
- D. Duct Sealant: Shall be fire resistant with a flame spread rating of 25 or less, and a smoke developed rating of 50 or less. Sealant shall also be water resistant and compatible with mating materials and types of joints or connections being sealed, specifically made for sealing ducts. Exterior duct sealant shall be specifically intended for outdoor use as a duct sealant.
- E. Duct Tape: Shall be fire resistant with a flame spread rating of 25 or less, and a smoke developed rating of 50 or less. Tape used shall be specifically compounded for maximum adhesion to galvanized steel, and shall be compatible with the duct sealant used.

**NISQUALLY STATE PARK
NEW FULL SERVICE PARK – PHASE 2**

2.3 LOW PRESSURE DUCT FABRICATION

- A. Duct Gauge and Reinforcement: Shall be as shown in SMACNA HVAC Duct Construction Standards according to the pressure classification of the system and the duct dimensions.
- B. Joints and Seams: Construct in accordance with SMACNA HVAC Duct Construction Standards. Leakage shall be less than 5% of total system airflow. Button punch or bolt connections in standing seams shall be spaced on centers not greater than 6" apart. Coordinate joint spacing with duct reinforcement requirements so that transverse joints having the required stiffness may be incorporated in the reinforcement spacing schedule.
- C. Elbows and Tees: Shall be long radius type with a center line radius not less than 1 1/2 times the width or diameter of the duct. Where space does not permit the use of long radius elbows, short radius or square elbows with turning vanes shall be used.
- D. Transitions: Increase duct sizes gradually. Transitions for diverging air flow shall be made with each side pitched out not more than 20 degrees. Transitions for converging air flow shall be made with each side pitched in not more than 30 degrees.
- E. Branch Connections: Duct take offs from rectangular ductwork to round ductwork shall be made using spin in fittings (unless a different fitting type is specifically shown). Duct take-offs from rectangular duct to rectangular duct shall be as shown on the drawings and in compliance with SMACNA Standards.
- F. Ductmate Systems: Transverse duct joints may be made with Ductmate System, or approved equal. System shall consist of companion flanges of 20 gauge galvanized steel with an integral polymer mastic seal; corner pieces of 12 gauge G90 galvanized steel; 20 gauge G90 galvanized cleats; closed cell, high density gasket type; and galvanized carriage bolts with hex nuts. The flanges shall be securely fastened to the duct walls using self-drilling screws, rivets or spot welding. Fastener spacing shall be as recommended by the manufacturer for the size of duct and the pressure class. The raw duct ends shall be properly seated in the integral mastic seal. A continuous strip of gasket tape, size 1/4" x 3/4", shall be installed between the mating flanges of the companion angles at each transverse joint; and the joint shall be made up using 3/8-inch diameter x 1-inch long plated bolts and nuts. Galvanized drive-on or snap-on cleats shall be used at spacings as recommended by the manufacturer.

2.4 DUCT LINING

- A. Material: Flexible, inorganic glass fiber material, maximum thermal conductivity of 0.26 Btu-inch/hr-sq. ft.-degree F at 75 degrees F, coated to prevent erosion, and conforming to SMACNA Duct Liner Application Standard. Lining shall be 1-inch thick on ductwork within the building and 2-inch thick on ductwork exterior of the building.
- B. Adhesives: Fire resistant, Type 1, conforming to the Standard for Adhesives for Duct Liner, ASC-A-7001C-1972, of the Adhesive and Sealant Council, as contained in the SMACNA Duct Liner Application Standard.
- C. Mechanical Fasteners: Shall conform to the Mechanical Fasteners Standard, MF-1-1975, as contained in the SMACNA Duct Liner Application Standard.

**NISQUALLY STATE PARK
NEW FULL SERVICE PARK – PHASE 2**

PART 3 - EXECUTION

3.1 SHOP DRAWINGS

- A. Shop drawings of all ductwork are required. Contractor shall field locate existing building features that may interfere with new ductwork. See Section 230500 General HVAC Requirements for drawing requirements.
- B. Contractor shall include in his bid a minimum of 2 hours per room for the creation of shop drawings.

3.2 DUCTWORK INSTALLATION

- A. Install all ductwork and plenums in sizes and locations as shown on the drawings, complete with all accessories and connections to provide complete and operable heating, ventilating, air conditioning, and exhaust systems.
- B. Ducts shall be installed level and in neat lines with the building construction.
- C. All ducts are to be installed concealed unless indicated otherwise.
- D. Apply a bead of duct sealant to all spin in fittings where fitting seals against sheet metal duct.
- E. Seal all joints in accordance with Seal Classification as shown in Table 1 2 of the SMACNA HVAC Duct Construction Standards. All "Ductmate" and similar systems shall be installed in strict accordance with manufacturer's instructions.
- F. In addition to applying sealant to joints in accordance with the SMACNA requirements, all joint corners and seams shall be sealed and all joints and seams shall be taped over with minimum 3-inch wide duct tape. Such tape is not required on exposed ducts, but all joint corners shall have adhesive applied. Exposed ducts shall be carefully sealed to maintain good appearance.
- G. Alternative Duct Sizes: The Contractor, at his option, may use duct sizes other than those shown on the drawings, provided that the Architect/Engineer gives prior approval, and the pressure drop per lineal foot of the proposed duct does not exceed that for the duct shown.

3.3 DUCT CLEANING AND TESTING

- A. All ducts shall be wiped or blown clean of all dust and debris prior to the installation of grilles or diffusers.
- B. All plenums shall be vacuum cleaned of all dust and debris prior to system operation.

END OF SECTION

**NISQUALLY STATE PARK
NEW FULL SERVICE PARK – PHASE 2**

SECTION 233300 – AIR DUCT ACCESSORIES

PART 1 - GENERAL

1.1 WORK INCLUDED

- A. Flexible Connections
- B. Manual Dampers
- C. Motorized Dampers

PART 2 - PRODUCTS

2.1 ACCEPTABLE MANUFACTURERS

- A. Products shall comply with Section 230500 General HVAC Requirements.

2.2 FLEXIBLE CONNECTIONS

- A. Provide flexible connections at all duct connections to fans, where ducts of dissimilar metals are connected, and where shown on the drawings.
- B. For round ducts, the flexible material shall be secured by zinc-coated, iron clinch type draw bands.
- C. For rectangular ducts, the flexible material shall be locked to metal collars which shall be connected to the duct using normal duct seam construction methods.
- D. Install flexible connections with sufficient slack to permit 2 inches of horizontal or vertical movement of ducts or equipment at flexible connection point without stretching the flexible material.
- E. Where installed exposed to outside weather, provide a galvanized "hat" channel protecting top and vertical stretches of flexible connector from sunlight and weather.

2.3 MANUAL DAMPERS

- A. Dampers shall be fabricated of galvanized steel, two gages heavier than duct in which installed.
- B. Maximum blade width is 12 inches; fabricate multi blade dampers with opposed blade pattern for ducts larger than 12" x 48".
- C. Damper regulator sets shall have quadrant dial regulator with locking nut, square end bearing one side, and spring round end bearing other side (small sizes) or open end square bearing (larger sizes), axis of blade the long dimension. Regulator sets shall be Duro Dyne Model numbers as

**NISQUALLY STATE PARK
NEW FULL SERVICE PARK – PHASE 2**

follows:

Max. Blade Dimension	Duro-Dyne Regulator Set	Shaft Size
10" and less	KS 145, 145L	1/4"
11" to 14"	KSR 195, 195L	3/8"
15" to 23"	SRS-388, SB-138, KP105	3/8"
24" and larger	SRS-128, SB-112, KP105	1/2"

- D. Multiple blade dampers shall have individual quadrants for each blade or one quadrant with interconnected blades.
- E. Flush mounted concealed type damper quadrants shall have prime paint finish, and shall be Ventfabrics No. 666 or Young Regulator Co. No. 301.

2.4 MOTORIZED DAMPERS

- A. Ruskin Model CD51 (or equal) low leakage control damper, with blade and jamb seals, Class II (or better) leakage rated, with factory installed actuators and related accessories to operate properly and in accordance with code and listing requirements. Where damper occurs immediately behind a wall inlet/outlet, damper shall be Ruskin Model CD51 (or approved equal), Class I leakage rated.
- B. Actuator shall be for use with 24 volt AC, 24 volt DC, or 120 volt AC power, and shall be the fail close type (close upon loss of power).
- C. Unit shall have a switch package to allow remote indication when the damper is in any position other than full open. Reference Section 230900 HVAC Controls for connections and remote indicating devices.

PART 3 - EXECUTION

3.1 INSTALLATION

- A. Install duct flexible connections at all duct connections to equipment. Installation shall not allow any "grounding" of vibrating machinery to ducts.
- B. Provide balancing dampers where shown and as required to perform balancing.

END OF SECTION

**NISQUALLY STATE PARK
NEW FULL SERVICE PARK – PHASE 2**

SECTION 233400 – FANS

PART 1 - GENERAL

1.1 WORK INCLUDED

- A. Ceiling Exhaust Fans.

1.2 QUALITY ASSURANCE

- A. Fans shall bear the AMCA certified seal unless indicated otherwise.

1.3 SUBMITTALS

- A. Submittals shall comply with Section 230500 General HVAC Requirements.
- B. Submit fan curves showing SP vs. CFM and BHP vs. CFM with system operating point clearly marked.
- C. Submit sound power level data showing sound power levels in decibels referenced to 10 watts for each of the eight octave bands (not required for fans under 1500 CFM). Submit sound power levels in sones for fans under 1500 CFM (or decibel values if available).

PART 2 - PRODUCTS

2.1 ACCEPTABLE MANUFACTURERS

- A. Products shall comply with Section 230500 General HVAC Requirements.
- B. Ceiling Exhaust Fans: Nutone, Cook, Greenheck, Acme, Penn.

2.2 GENERAL

- A. Motors: Shall be U.L. listed and as specified in Section 230500 General HVAC Requirements. Motors shall have adjustable supports for adjusting belt tension. Provide explosion proof motors in accordance with NEC Class 1 group D standards where indicated on the drawings.
- B. Capacity: Fan capacity shall not be less than the values listed in the Fan Schedule on the drawings.
- C. Outlets and Inlets: Equipment shall be furnished with attachment angles and/or flanges as required for attaching ductwork flexible connections as shown on the drawings.
- D. Fan Types: The type of each fan is indicated on the Fan Schedule, under the "Type" column, and corresponds to the types specified herein.

**NISQUALLY STATE PARK
NEW FULL SERVICE PARK – PHASE 2**

- E. Fan Performance Ratings: Shall be based on laboratory tests conducted in accordance with AMCA Test Codes.
- F. Fan Arrangement and Drive: Shall be as shown on the drawings.
- G. Electrical: Fan disconnects and motor starters shall comply with Division 26 specifications. Disconnects furnished with fan shall come factory wired to motor.
- H. Finish: All fans shall have factory applied enamel finish (manufacturer's standard color) over a rust inhibiting primer base coat.
- I. Backdraft Dampers: Provide all exhaust fans with backdraft dampers, constructed of aluminum or galvanized steel, having felt or neoprene lined edges. Shall be "butterfly" type where used on fans with round connections. Backdraft dampers shall be gravity type unless indicated to be motorized type.
- J. Weatherproof: Where installed exposed to weather, fans shall have weatherproof enclosure, preventing any wind driven water entry into unit or drive assembly.

2.3 CEILING EXHAUST FANS

- A. Type: Ceiling Exhaust fan. Nutone QTXEN or approved.
- B. Housing: Shall be constructed of galvanized steel, with inlet and outlet duct connection collars, spring-loaded discharge damper, adjustable mounting brackets for wall or ceiling mounting, and minimum 1/2" – 1-1/2" lb./cubic foot density fiberglass duct liner insulation. Fan shall have access panel allowing access to fan motor and scroll without disturbing fan housing, ductwork, or wiring.
- C. Fan Wheel(s): Unit shall have forward curved centrifugal type fan wheel(s). Wheel(s) shall be statically and dynamically balanced. Provide twin fan wheels when indicated on the Fan Schedule or where required to provide capacity indicated.
- D. Drive: Fan shall be direct drive, with drive assembly mounted on vibration isolators.
- E. Accessories: Provide the following accessories where indicated on the fan schedule or shown on the drawings:
 - 1. Speed Controls: Solid state speed controller allowing speed reduction down to 50% of maximum.
 - 2. Disconnect Switch: Factory mounted on side of cabinet or within unit but so as to be accessible when unit is installed. Disconnect shall consist of switch or receptacle and plug-in power cord assembly; no added field devices shall be needed.

2.4 CABINET EXHAUST FANS

- A. Type: In line, centrifugal cabinet fan. Greenheck model CSP or approved.

**NISQUALLY STATE PARK
NEW FULL SERVICE PARK – PHASE 2**

- B. Housing: Shall be constructed of galvanized steel, with inlet and outlet duct connection collars, spring loaded discharge backdraft damper, adjustable mounting brackets for wall or ceiling mounting, and minimum 1/2" 1-1/2 lb/cubic foot density fiberglass duct liner insulation. Fan shall have access panel allowing access to fan motor and scroll without disturbing fan housing, ductwork or wiring.
- C. Fan Wheel(s): Unit shall have forward curved centrifugal type fan wheels(s). Wheel(s) shall be statically and dynamically balanced. Provide twin fan wheels when indicated on the Fan Schedule or where required to provide capacity indicated.
- D. Drive: Fan shall be direct drive, with drive assembly mounted on vibration isolators.
- E. Accessories: Provide the following accessories where indicated on the Fan Schedule or shown on the drawings:
 - 1. Speed Controls: Solid state speed controller allowing speed reduction down to 50% of maximum.
 - 2. Disconnect: Factory mounted on side of cabinet or within unit but so as to be accessible when unit is installed. Disconnect shall consist of switch or receptacle and plug-in power cord assembly; no added field devices shall be needed.

PART 3 - EXECUTION

3.1 INSTALLATION

- A. Install fans at locations and as shown on the drawings.
- B. Install fans in accordance with Manufacturer's recommendations and instructions.
- C. Fans with solid state speed controllers shall have the speed controller mounted on the fan housing unless another location is indicated on the drawings (for use by Balancer).
- D. Provide flexible connections in ductwork connections to all fans.
- E. Install all fans with vibration isolators so that no sound or vibration is transmitted to the structure. See Section 230548 HVAC Vibration & Seismic Control for vibration isolation specifications.
- F. Prior to air balancing, check fans for correct rotation, tighten belts to proper tension, adjust fan rpm to value shown on drawings, and lubricate bearings per manufacturer's recommendations.

END OF SECTION

**NISQUALLY STATE PARK
NEW FULL SERVICE PARK – PHASE 2**

SECTION 233700 – AIR OUTLETS AND INLETS

PART 1 - GENERAL

1.1 WORK INCLUDED

- A. Supply Outlets.
- B. Return Inlets.
- C. Exhaust Inlets.
- D. Louvers.
- E. Wall Caps.

1.2 REFERENCES

- A. SMACNA HVAC Duct Construction Standards, Current Edition.

1.3 SUBMITTALS

- A. Shall comply with Section 230500 General HVAC Requirements.
- B. Submit product information on all items.

PART 2 - PRODUCTS

2.1 ACCEPTABLE MANUFACTURERS

- A. Products shall comply with Section 230500 General HVAC Requirements.
- B. Diffusers, Grilles, Registers, and Door Louvers: Carnes, Anemostat, Titus, Metal-Aire, Krueger, J & J Register, Price, Tuttle & Bailey.
- C. Outside Louvers: Ruskin, American Warming and Ventilating, Air Balance, Penn, Dowco, Wonder-Metals, Vent Products.
- D. Wall and Roof Caps: Greenheck, Penn, Nutone, Carnes.

**NISQUALLY STATE PARK
NEW FULL SERVICE PARK – PHASE 2**

2.2 GENERAL REQUIREMENTS

- A. Air outlets shall be of the size, type, and with number of throws as shown on the drawings; and shall match the appearance and performance of the manufacturers' models specified and scheduled on the drawings.
- B. Air outlet application shall be based on a noise level of NC 35 maximum.
- C. Furnish all necessary screws, clips, duct collars, and transitions required to allow for the air outlet installation and connection to ductwork.
- D. Finish: Factory enamel finish, color as selected by Architect/Engineer, except that LSG type and any other wall inlets/outlets used in the same room/area as the LSG shall have brushed aluminum finish.
- E. Frame Style: Provide air outlets and inlets with frame style to match ceiling or wall construction installed in. Where supply air outlets or inlets are installed in T-bar ceiling systems, they shall be factory installed in 2' x 2' or 2' x 4' metal panel to match ceiling layout. Where installed against gypsum board surface, brick or similar hard surface or, where exposed, provide with 1-1/4" wide outer border. Where space does not permit installing 2' x 2' metal panel, provide outlets or inlets with 1-1/4" wide outer border. Where air outlets are installed adjacent to surface mounted light fixtures, outlets shall have 4-inch deep drop frames. (See reflected ceiling plan and/or electrical lighting plan for ceiling type and allowable space).
- F. Contractor shall measure actual louver wall openings prior to ordering or fabricating louvers. Notify Architect/Engineer of any discrepancy between actual wall opening and specified opening.
- G. Ceiling transfer grilles (TG) shall be same as CEG's unless specifically shown otherwise; wall transfer grilles (WTG) shall be same as WEG unless specifically shown otherwise.

2.3 SUPPLY AIR OUTLETS

- A. Ceiling Diffuser (CD): Shall be of aluminum or steel construction, have louver face and square neck (integral round neck is acceptable provided that performance equal to specified diffuser is provided). Cores shall be easy snap-in/out core installation - with no tools required. Provide with air flow grid to allow uniform airflow. Grids shall be comprised of a single set of extruded aluminum vanes set on 2/3" centers and tapered to a semi-air-foil shape for greater performance efficiency. Titus TDC.
- B. Wall Supply Grill (WSG): Shall be of aluminum or steel construction, double deflection type, with horizontal face bars and vertical rear bars. Unit shall have outer frame borders 1-1/4" wide, gasket to prevent air leakage and minimize smudging. Deflecting bars shall be rigid extruded aluminum of semi-air-foil design, on 3/4" centers. Vertical and horizontal bars shall be adjustable. Titus 300RS.

**NISQUALLY STATE PARK
NEW FULL SERVICE PARK – PHASE 2**

2.4 RETURN AIR INLETS

- A. Ceiling Return Grille (CRG): Aluminum construction, "cube-core" or "egg-crate" type, with 0.025" thick X 1/2" deep strips mechanically joined to form 1/2" x 1/2" x 1/2" cubes, and opposed blade damper operable from face of register. Titus 50F.
- B. Ceiling Return Grille – Type A (CRG-A): Steel construction, with 5/16" diameter perforations on staggered 7/16" centers in faceplate. Titus SG-PR.

2.5 EXHAUST AIR INLETS

- A. Ceiling Exhaust Grille (CEG): Same as CRG.
- B. Ceiling Exhaust Grille – Type A (CEG-A): Same as CRG-A.

2.6 4-INCH DEEP LOUVERS – ALUMINUM BLADES

- A. Type: High performance, 4-inch deep, stationary, drainable louvers. Ruskin Model ELF375D or approved.
- B. Frame: 4-inch deep, constructed of a minimum 0.090-inch, 6063 extruded aluminum, with integral caulking slots and downspouts in jambs and mullions.
- C. Blades: Shall be constructed of minimum 0.081-inch, 6063 extruded aluminum, at 37.5 degree angle, on approximately 3-inch centers, with drain gutter.
- D. Bird Screen: Shall be constructed of 1/2-inch mesh, 0.051-inch aluminum.
- E. Performance: Nominal free area of 50% with pressure drop and water penetration equal to specified manufacturer's model.
- F. Wind Loading: Louver shall incorporate structural supports required to withstand a wind load of 30 pounds per square foot.
- G. Finish: Provide with standard mill finish.

2.7 WALL CAPS

- A. Masonry Walls:
 - 1. For Airflows of 500 cfm and Less: Anodized aluminum brick vent, with birdscreen. 16" wide x 8" high, Greenheck Model No. BV-16x8 or approved equal.
 - 2. For Airflows of 501 cfm up to 1000 cfm: Shall be 4" deep extruded louvers, drainable type, 24" wide x 18" high, Ruskin ELF811D-55 or approved.

**NISQUALLY STATE PARK
NEW FULL SERVICE PARK – PHASE 2**

B. Non-Masonry Walls:

1. For Airflows of 250 cfm and Less: Wall caps shall be constructed of anodized aluminum, with bird screen and built-in backdraft damper, 10" wide x 3" high, Greenheck Model No. WL-10x3.
2. For Airflow of 251 cfm up to 500 cfm: Wall caps shall be constructed of anodized aluminum, with bird screen and built-in backdraft damper, 16" wide x 8" high, Greenheck Model No. WL-18x6.
3. For Airflows of 501 cfm up to 1000 cfm: Shall be 4" deep extruded louvers, drainable type. 24" wide x 18" high, Ruskin ELF375DX or approved.

2.8 DRYER VENT CAPS

- A. Dryer Vent Caps: Shall be of aluminum construction with integral backdraft damper. Nutone No. 885-AL (wall) or 841-AL (roof) or custom fabricated type to suit application. Provide painted finish to match adjacent surface area color.

2.9 MISCELLANEOUS

- A. Screen: 1/2-inch mesh, constructed of either 0.051-inch aluminum wire or 19-gauge galvanized steel wire.

PART 3 - EXECUTION

3.1 INSTALLATION

- A. Install air outlets in locations shown on the drawings and so as to conform with architectural features and lighting arrangements.
- B. Paint ductwork which is visible behind air inlets and outlets flat black.
- C. All outlets and inlets exposed to the weather shall be adequately flashed and installed in a manner to assure complete weatherproofness.
- D. Sealing and caulking of all outlets and inlets exposed to the weather shall conform to Division 7 requirements.
- E. Provide screened openings (SO) on all duct openings where indicated and where openings do not have grilles or registers.
- F. Coordinate with the Division 9 Contractor for any necessary painting of air inlets/outlets/louvers/etc. prior to installation.

END OF SECTION

**NISQUALLY STATE PARK
NEW FULL SERVICE PARK – PHASE 2**

SECTION 237200 – HEAT RECOVERY UNITS

PART 1 - GENERAL

1.1 WORK INCLUDED

- A. Energy Recovery Units.
- B. Installation.
- C. Start up.

1.2 DEFINITIONS

- A. "ESP" is defined to mean external static pressure, measured external to the units' duct connection collars but including a pressure drop for the units' filters and any added heating or cooling coils.

1.3 QUALITY ASSURANCE

- A. Units shall be UL listed and labeled.
- B. Units shall be rated in accordance with ARI standards.

1.4 SUBMITTALS

- A. Shall comply with Section 013300 Submittal Procedures.
- B. Provide complete product information submittals on all units; include performance capacities as a function of indoor and outdoor coil db/wb temperatures and indoor coil air flow rates; supplementary heater capacity; fan performance (cfm vs. esp); and information on all filters and accessories.

PART 2 - PRODUCTS

2.1 ACCEPTABLE MANUFACTURERS

- A. Products shall comply with Section 23050 General HVAC Requirements.
- B. Energy Recovery Units—Static Plate Type: Mitsubishi, RenewAire, Panasonic, Fantech.

**NISQUALLY STATE PARK
NEW FULL SERVICE PARK – PHASE 2**

2.2 ENERGY RECOVERY UNTIS – STATIC PLATE TYPE

- A. Type: Energy recovery units using static plate heat exchanger. Mitsubishi Lossnay LGH series or approved.
- B. General: Unit shall provide equivalent performance and capacity to scheduled units and shall have equivalent or superior features (not all such features are specifically listed in this section). Unit shall be factory assembled, factory tested, self-contained package, ready for field connection of ductwork, plumbing and electrical services.
- C. Construction: External cabinet shall be 20 gauge, G90 galvanized steel, with inlet and outlet duct connection collars, spring-loaded discharge backdraft dampers, and adjustable mounting brackets. Housing shall be double wall insulated with 1-inch thick, 3 pound density fiberglass. Service/access doors shall be fully gasketed and insulated.
- D. Heat Exchange Module: Shall be cross-flow or counter flow static plate type. The heat exchanger module shall be tested to AHRI Standard 1060 for efficiency and pressure drop by an independent test lab. Copies of the test shall be part of the submittal data.
- E. Fan Wheel(s): Unit shall have forward curved centrifugal type fan wheel(s). Wheel(s) shall be statically and dynamically balanced. Provide twin fan wheels when indicated on the Fan Schedule or where required to provide capacity indicated.
- F. Drive: Fan(s) shall be direct drive, with drive assembly mounted on vibration isolators.
- G. Electrical: Unit shall have single point electrical power connection. Each unit shall be wired and tested at the factory before shipment. Wiring shall comply with NEC requirements and shall conform to all applicable UL standards. All wiring shall be number coded per the electrical wiring diagrams. All electrical components shall be labeled according to the electrical diagram and be UL recognized where applicable. The supply and return air fan circuits shall be individually fused. Thermal overload protection shall be furnished for each fan motor. The supply and return air fan motors shall have motor starter contactors and external overload protection. A terminal block shall be provided for the main power connection and a terminal board shall be provided for the low voltage control wiring. Knockouts shall be provided in the bottom of the main control panel for field wiring entrance. Unit shall have unfused disconnect to cut power to entire unit before control panel can be opened.
- H. Accessories: Provide the following accessories where indicated on the Schedule or shown on the drawings:
 - 1. Speed Controls: Solid state speed controller allowing speed reduction down to 50% of maximum.
 - 2. Disconnect: Factory mounted on side of cabinet or within unit but so as to be accessible when unit is installed. Disconnect shall consist of switch or receptacle and plug-in power cord assembly; no added field devices shall be needed.
 - 3. Motion (Occupancy) Sensor: Passive infrared sensor for ceiling mounting with adjustable time-off delay.

**NISQUALLY STATE PARK
NEW FULL SERVICE PARK – PHASE 2**

PART 3 - EXECUTION

3.1 INSTALLATION

- A. Install the heat recovery coil and heat recovery units as shown on the drawings and in accordance with manufacturer's instructions.
- B. Provide flexible connection at the duct connections to heat recovery coils in ducts, in accordance with the manufacturer's recommendations to allow for tilting of the coil.
- C. Provide flexible connections in ductwork connections to all units. Provide type complying with NFPA 96 on exhaust side of kitchen heat recovery units.
- D. All drains from plenums and drain pans shall be piped to the closest drain or as indicated on the drawings.
- E. The drawings show design configurations based on particular manufacturer's equipment. If contractor's selected manufacturer's equipment configured different from that which is shown, the Contractor shall provide all necessary modifications to ductwork, support systems, electrical requirements, and piping systems as required to accommodate furnished equipment at no additional cost to the Owner.
- F. Supplier shall include in bid, cost for changing sheaves on all fans to suit balancer and actual field requirements.

3.2 START UP

- A. Initial Checks: Prior to operating units, checks shall be made to insure that adequate voltage, plumbing connections (where applicable), duct connections, electrical connections, control connections, and other items as listed by the manufacturer are properly provided/connected and operating to insure safe and proper unit operation.
- B. Testing and Adjustment: Operate unit in various modes of operation to test for proper operation, including fan rotation, proper damper travel (where applicable), proper cooling/heating, correct interface to other controls (time clock, fans, etc.), coil temperature controls, etc. Tighten belts to proper tension, lubricate bearings, and make all other necessary adjustments, all per manufacturer's directions.
- C. Final Check: When the testing and adjustment is complete, a final check of each unit shall be done by the manufacturer's authorized service representative, or direct employee, to verify proper unit operation. Any defective items shall be repaired or replaced by the contractor until proper operation is confirmed by the manufacturer's authorized service representative.

**NISQUALLY STATE PARK
NEW FULL SERVICE PARK – PHASE 2**

- D. **Written Report:** When the final check has been completed, a written report from the manufacturer's authorized service representative shall be provided. This report shall list all units checked, items checked, check results, any items which may impair proper unit operation, and the name and phone number of the actual individual(s) doing the check. The report shall include a statement stating whether or not all units are operating as specified.

END OF SECTION

**NISQUALLY STATE PARK
NEW FULL SERVICE PARK – PHASE 2**

SECTION 238100 – AIR CONDITIONING EQUIPMENT

PART 1 - GENERAL

1.1 WORK INCLUDED

- A. Split System Heat Pump
- B. Refrigeration Piping
- C. Start-Up
- D. Owner Training and Instruction

1.2 SUBMITTALS

- A. Submittals shall comply with Section 230500.
- B. Submit product information on all products.
- C. Provide complete product information submittals on all units; include performance capacities as a function of indoor and outdoor coil db/wb temperatures and indoor coil air flow rates; fan performance (cfm vs. esp); and information on all filters and accessories. Provide information showing dimensions and location of all connections.

1.3 QUALITY ASSURANCE

- A. Unit shall be rated in accordance with ARI standard 590.
- B. Unit construction shall be designed to conform to ANSI/ASHRAE 15, NEC, Washington State Energy Code and applicable ASME codes.
- C. Unit shall be fully tested at the factory prior to shipment.

1.4 WARRANTY

- A. Entire air conditioning units shall be warranted by the manufacturer for 5 years after acceptance by the Owner.

PART 2 - PRODUCTS

2.1 ACCEPTABLE MANUFACTURERS

- A. Products shall comply with Section 230500, Paragraph 2.01, Acceptable Manufacturers.

**NISQUALLY STATE PARK
NEW FULL SERVICE PARK – PHASE 2**

- B. Split System Heat Pump: Mitsubishi, Daikin, LG.

2.2 SPLIT SYSTEM HEAT PUMP

- A. Type: Split system ductless heat pump.
- B. General: Units shall be fully factory assembled and shall be complete with casing, coils, fans, compressor(s), piping, wiring, controls, and all other accessories required to be ready for field connections and operation. Units shall be UL listed and labeled.
- C. Indoor Unit(s): Wall-mounted unit(s), with fan, adjustable discharge outlets, evaporator coil, refrigerant metering device, heavy gauge steel chassis, refrigerant piping controls, condensate pan and drain connection, and related accessories to operate properly with outdoor unit.
- D. Outdoor Unit: Outdoor condenser and compressor unit, with high efficiency rotary type compressor, condenser coil, condenser fan, accumulator, reversing valve, refrigerant piping, wind baffle accessory, heavy gauge steel chassis, baked enamel finish steel cabinet, controls, and related accessories to provide capacity indicated.
- E. Capacity: Units shall have minimum cooling and heating capacities as scheduled on the drawings at the conditions shown and with the indoor coil indicated; and shall be rated in accordance with ARI standards. Unit shall be capable of operating in the cooling mode from 14 to 115 degrees F ambient, and in the heating mode from 59 to -4 degrees F ambient. Unit shall be able to operate with refrigerant runs up to 100 feet long.
- F. Controls: Indoor and outdoor units shall be provided with all contactors, relays, terminals, safety controls, microprocessor devices, and accessories to allow for complete unit operation; requiring only connection of room controller and interconnection between indoor and outdoor units. Room controller shall be electronic type, with liquid crystal display. Controller shall have temperature sensor, on/off/auto functions, temperature setpoint, fan speed indicator, and self diagnostic display.
- G. Refrigerant: Units shall be for use with refrigerant R-410A.
- H. Warranty: One year warranty on all components; six year warranty on compressor (excluding installation labor).

2.3 REFRIGERATION PIPING

- A. ACR Type L copper tubing, with silver brazed joints and wrought copper fittings. Mechanical flared fittings may be used at connections to equipment.

PART 3 - EXECUTION

3.1 INSTALLATION

- A. Install all equipment at locations and as shown on the drawings.

**NISQUALLY STATE PARK
NEW FULL SERVICE PARK – PHASE 2**

- B. Install in strict accordance with manufacturer's instructions.
- C. Connect and install all items shipped loose with units.

3.2 LEAK TESTING AND EVACUATION

- A. Connect a vacuum pump to the piping system and evacuate the system to 500 microns, and let stand for a minimum of 12 hours. If the vacuum reading remains unchanged, the system may be charged with refrigerant.

3.3 REFRIGERATION SYSTEM

- A. Install all refrigeration system components as recommended by the air conditioner manufacturer. At a minimum these shall include a sight glass, service valves, expansion valves, and external filter/drier.

3.4 START-UP

- A. General: Start-up and subsequent system checks shall be done by the manufacturer's authorized service representative.
- B. Initial Checks: Prior to operating units, checks shall be made to insure that all equipment, piping, and controls are connected and operating properly. As a minimum, check for: proper voltage and phases, correct compressor oil level, valves open, correct electrical connections, complete control connections, overload heaters installed in compressor motor starter, hi and lo pressure cutouts properly set and connected, unit heaters operational, condenser fans rotating correctly, fans lubricated, coils clear of obstructions, and other items as listed by the manufacturer are properly provided/connected and operating to insure safe and proper unit operation.
- C. 72 Hour Checks: Provide checks in accordance with manufacturer's instructions; as a minimum review the following:
 - 1. Observe the compressor oil level. If low, operate the system for three to four hours, checking the oil level frequently. If it remains low, add oil.
 - 2. Check the refrigerant flow in the liquid line sight glass. The flow should be solid with no evidence of flash gas. If bubbles of flash gas appear, check the system for leaks; repair if necessary and add refrigerant.
 - 3. Check the temperature of the liquid line from the inlet of the filter-drier to the expansion valve. The temperature should be uniform. If a decided temperature difference exists across a valve or fitting, a restriction is evident. The restriction is causing a pressure drop which, in turn, is causing the refrigerant to flash. Such a pressure drop produces bubbles of flash gas which will appear in the sight glass. Remove and clean the restricted part.
 - 4. Measure the superheat of the suction gas. If necessary, readjust the superheat setting of the expansion valve.
 - 5. Observe the system operating pressures. If they appear normal, close the gauge valves.
- D. One Week Check: After the system has been in full operation for one week, provide these final checks and adjustments:

**NISQUALLY STATE PARK
NEW FULL SERVICE PARK – PHASE 2**

1. Replace the core of the compressor filter-drier. (Or if start-up has occurred in off season, provide extra cores to Owner).
2. Observe the general operation of the system: system pressures, compressor oil level, liquid line sight glass, condensing equipment, etc.
3. Written Report: When all of the above checks have been completed, a written report from the manufacturer's authorized service representative shall be provided. This report shall list all units checked, items checked, check results, any items which may impair proper unit operation, and the name and phone number of the actual individual(s) doing the check. The report shall include a statement stating whether or not all units are operating as specified. Separate data/record sheets shall be provided for each of the above units.

3.5 OWNER INSTRUCTION

- A. After all testing and adjustments have been satisfactorily completed, the Owner shall be provided with operator instructions (including start-up, shut-down, emergency, maintenance, and repair instructions) by the manufacturer's authorized service representative.
- B. Time Period: Instruction period shall be for a minimum of four (4) hours.
- C. Instruction and notification shall comply with Section 230500.

END OF SECTION

**NISQUALLY STATE PARK
NEW FULL SERVICE PARK – PHASE 2**

SECTION 238300 – ELECTRIC SPACE HEATING EQUIPMENT

PART 1 - GENERAL

1.1 WORK INCLUDED

- A. Radiant Electric Heaters.

1.2 QUALITY ASSURANCE

- A. Units shall be UL listed and labeled.

1.3 SUBMITTALS

- A. Submittals shall comply with Section 230500 General HVAC Requirements.
- B. Provide complete product information submittals on all units; include heater capacities; electrical requirements (voltage, amps); and information on all accessories.

PART 2 - PRODUCTS

2.1 ACCEPTABLE MANUFACTURERS

- A. Products shall comply with Section 230500 General HVAC Requirements.
- B. Radiant Electric Heaters—Frame-In Ceiling Type: TPI Corporation; Indeeco.
- C. Radiant Electric Heaters—‘T’-Bar/ACT Ceiling Type: TPI Corporation; Indeeco.
- D. Radiant Cove Heaters: King, Qmark.

2.2 GENERAL

- A. General: Unit shall provide equivalent performance and capacity to scheduled units and shall have equivalent or superior features (not all such features are specifically listed in this section). Unit shall be factory assembled, factory tested, self-contained package, ready for field connection of ductwork, plumbing, and electrical services.
- B. Capacity: Unit capacity shall not be less than the values listed in the Electric Heater Schedule on the drawings.
- C. Heater Types: The type of each unit is indicated on the Electric Heater Schedule, under the "Type" column, and corresponds to the types specified herein.

**NISQUALLY STATE PARK
NEW FULL SERVICE PARK – PHASE 2**

- D. Electrical: Unit disconnects shall comply with Division 26 specifications. Disconnects furnished with unit shall come factory wired to unit. Thermal overload protection shall be furnished for each unit. Unit shall be provided with knockouts for field wiring entrance or with factory-wired cabling for field connections.
- E. Finish: All units shall have factory applied enamel finish (manufacturer's standard color) over a rust inhibiting primer base coat.

2.3 SURFACE-MOUNT RADIANT CEILING PANEL

- A. Type: Radiant electric heater, for surface-mounted ceiling installation. TPI Corporation CP series or approved.
- B. Construction: Shall be constructed of minimum 22 gage steel, with factory mounting tabs and recessed-mount support frame. Rear of casing shall be rated for zero clearance to combustibles.
- C. Heating Elements: Shall consist of insulated electric resistance wire affixed to radiating surface of panel and covered by min 2” high-temperature-rated nonflammable insulation to reduce heat loss through rear of panel.
- D. Accessories: Provide the following accessories where indicated:
 - 1. Disconnect Switch: Factory mounted on rear or side of cabinet or within unit but so as to be accessible when unit is installed. Disconnect shall consist of switch or receptacle and plug-in power cord assembly; no added field devices shall be needed.
 - 2. Temperature Controls: SPDT line-voltage thermostat. Thermostat shall be for mounting in a standard wall box.
 - 3. Humidity Protection: Panel casing shall be factory sealed with silicone to prevent incursion of moisture.
 - 4. Surface Mounting Frame: Aluminum frame for surface-mount installation, painted to match panel finish.

2.4 T-BAR/ACT RADIANT CEILING PANEL

- A. Type: Radiant electric heater, for installation in suspended ‘T’-bar/ACT ceiling systems. TPI Corporation CP series or approved.
- B. Construction: Shall be constructed of minimum 22 gage steel, with factory mounting tabs and recessed-mount support frame. Rear of casing shall be rated for zero clearance to combustibles.
- C. Heating Elements: Shall consist of insulated electric resistance wire affixed to radiating surface of panel and covered by min 2” high-temperature-rated nonflammable insulation to reduce heat loss through rear of panel.
- D. Accessories: Provide the following accessories where indicated:
 - 1. Disconnect Switch: Factory mounted on rear or side of cabinet or within unit but so as to be accessible when unit is installed. Disconnect shall consist of switch or receptacle and plug-in power cord assembly; no added field devices shall be needed.

**NISQUALLY STATE PARK
NEW FULL SERVICE PARK – PHASE 2**

2. Temperature Controls: SPDT line-voltage thermostat. Thermostat shall be for mounting in a standard wall box.
3. Humidity Protection: Panel casing shall be factory sealed with silicone to prevent incursion of moisture.

2.5 RADIANT COVE HEATERS

- A. Type: Radiant electric cove heater. King KCV series or approved.
- B. Construction: Shall be constructed of extruded aluminum, with factory mounting tabs. Rear of casing shall be rated for zero clearance to combustibles.
- C. Heating Elements: Shall consist of insulated electric resistance wire affixed to radiating surface of panel.
- D. Accessories: Provide the following accessories where indicated:
 1. Disconnect Switch: Factory mounted on rear or side of cabinet or within unit but so as to be accessible when unit is installed. Disconnect shall consist of switch or receptacle and plug-in power cord assembly; no added field devices shall be needed.
 2. Temperature Controls: SPDT line-voltage thermostat. Thermostat shall be for mounting in a standard wall box.

PART 3 - EXECUTION

3.1 INSTALLATION

- A. Install heaters at locations and as shown on the drawings.
- B. Install heaters in accordance with Manufacturer's recommendations and instructions.

END OF SECTION

**NISQUALLY STATE PARK
NEW FULL SERVICE PARK - PHASE 2**

SECTION 260126 - MAINTENANCE TESTING FOR ELECTRICAL SYSTEMS

PART 1 - GENERAL

1.1 WORK INCLUDED

- A. Bidding documents including Division 1 General Conditions, Published Addenda and related work in other Divisions form an integral part of these Specifications and shall be binding on the Division 26 Contractor for all work performed under Division 26, Electrical.
- B. Perform tests of the electrical system to assure NEC, WAC, WSNREC code compliance and proper system operation according to the intent of the contract documents.
- C. Applicable Codes, Standards & References for Tests:
All inspections and tests shall be in accordance with the following applicable codes and standards except as provided otherwise herein.
 - 1. National Electrical Code - NEC
 - 2. National Electrical Manufacturer's Association - NEMA
 - 3. American Society for Testing and Materials - ASTM
 - 4. Institute of Electrical and Electronic Engineers - IEEE
 - 5. National Electrical Testing Association - NETA
 - 6. American National Standards Institute - ANSI
 - 7. Washington Administrative Code - WAC
 - 8. Insulated Cable Engineers Associate - ICEA
 - 9. Association of Edison Illuminating Companies – AEIC
 - 10. Washington State Non-Residential Energy Code - WSNREC

1.2 CIRCUIT TESTS

- A. Contractor shall perform routine insulation resistance, continuity and grounding tests for all distribution and utilization equipment prior to connection and energization. A standard megger-type instrument shall be used to demonstrate insulation values are acceptable, ground system is continuous and the neutral system is isolated from the grounding system except at the electrical systems' single ground point.
- B. System defects, indicated by the circuit tests, shall be corrected by the Contractor. Tests and corrections shall be repeated by the Contractor until satisfactory results are obtained.

1.3 GROUNDING TEST

- A. Measure the ohmic value of the Electrical Service Entrance "System Ground" with reference to "Earth Ground" using multiple terminal, fall of potential methods and suitable test instruments.

**NISQUALLY STATE PARK
NEW FULL SERVICE PARK - PHASE 2**

- B. Maximum resistance to ground shall be less than 10 ohms unless lower values are specified in the contract documents. Notify the Architect/Engineer if this resistance value is not obtained for the initially installed system. Contractor shall provide corrective measures required to reduce ground resistance to less than 10 ohms.

1.4 MOTOR AND EQUIPMENT TESTS

- A. Request and obtain approved mechanical shop drawing submittals prior to electrical rough in and notify Engineer of any discrepancies.
- B. Verify proper rotation of all motors before placing into service.
- C. Measure and record electrical data for each motor installed under this contract. Data shall include these items:
 - 1. Motor description
 - 2. Controller description
 - 3. Motor nameplate amperes
 - 4. Actual measured motor running amperes
 - 5. Overload heater manufacturer and catalog numbers
 - 6. Overload heater ampere range
 - 7. Voltage (measured) and phase
- D. Motor controller overload heaters shall be sized to the actual motor nameplate full load current; do not oversize overload heaters.

1.5 PHASE BALANCE TESTS

- A. Verify the balance of the electrical system's phase currents. Reassign load connections necessary to obtain a balance acceptable to the Electrical Inspector and Engineer.

1.6 WSNREC – Systems Commissioning – C408

- A. Perform and document WSNREC systems commissioning requirements for lights, lighting controls and switched receptacles.

PART 2 - PRODUCTS

2.1 MATERIALS AND INSTRUMENTATION

- A. The contractor and/or testing agency shall supply all apparatus and materials required for indicated tests.

**NISQUALLY STATE PARK
NEW FULL SERVICE PARK - PHASE 2**

- B. Contractor shall include all costs associated with testing in bid proposal.

2.2 TEST REPORT(S)

- A. Furnish electronic PDF copy of test reports and documentation for inclusion into the project operation and maintenance manuals. Each test report shall include the following items:
 - 1. Name, address and telephone number of the testing agency.
 - 2. Name(s) of personnel conducting the tests
 - 3. Type of test
 - 4. Description of test procedure
 - 5. List of items tested
 - 6. List of actual test equipment including make, model(s), serial number(s) and calibration date(s) as applicable.
 - 7. Test results
 - 8. Conclusion and recommendations
 - 9. Appendix, including appropriate test forms
- B. Provide test reports for all tests listed above in paragraphs 1.3, 1.4, 1.5 and 1.6.

PART 3 - EXECUTION

3.1 TESTING PROCEDURE

- A. All tests shall be conducted according to applicable industry standards.

3.2 SCHEDULING

- A. Notify Architect/Engineer and Owner at least five (5) working days prior to performance of any recorded test.

END OF SECTION

**NISQUALLY STATE PARK
NEW FULL SERVICE PARK - PHASE 2**

SECTION 260500 - COMMON WORK RESULTS FOR ELECTRICAL SYSTEMS

PART 1 - GENERAL

1.1 GENERAL CONDITIONS

- A. Bidding documents including Division 00 General Conditions, Published Addenda and related work in other Divisions form an integral part of these Specifications and shall be binding on the Division 26 Contractor for all work performed under Division 26, Electrical.
- B. General requirements for materials and installation methods.

1.2 DEFINITIONS

- A. The term "provide" shall mean furnish, install and connect equipment and materials complete in operating condition.
- B. The term "approved" as used herein shall mean the written approval of the Engineer.
- C. The term "Contractor" as used herein shall mean the organization responsible for accomplishing all work within the contract documents. The plural term "contractors" as used herein shall include all of the trade organizations that comprise the project workforce.
- D. The term "drawings" as used herein shall mean all contract drawings for all divisions of work.
- E. The term "code" as used herein shall mean all applicable National, State and local codes.

1.3 SCOPE OF WORK

- A. The Electrical work consists of furnishing, installing, testing and placing in satisfactory operation all equipment, materials, devices and appurtenances, necessary to provide complete systems according to the intent of the Drawings and Specifications. In general this includes all labor, materials, equipment, tools, etc. to complete the electrical work.
- B. Electrical work requirements and products are not limited to electrical drawings and specifications. There is additional electrical work required to be included in the bid, indicated on the architectural, landscape, civil and mechanical drawings and respective specification sections. Contractor shall review all civil, landscape, architectural, structural, mechanical drawings and specifications for additional electrical information prior to bid and include the necessary costs to complete the electrical work in the electrical bid.
- C. Contractor shall coordinate with OHOP Mutual and Rainier Connect. Provide for their services (power/communications) to the site and project in the electrical bid.

**NISQUALLY STATE PARK
NEW FULL SERVICE PARK - PHASE 2**

1.4 INTENT OF DRAWINGS

- A. The Electrical drawings are intended to serve as working drawings for general layout. Equipment, receptacles, tele/data, fire alarm, switches, panels, lights, lighting controls, disconnects and raceways are partially diagrammatic and do not necessarily indicate actual routings or all appurtenances required for a complete installation. Do not scale electrical drawings. Take all measurements from field measurements.
- B. The drawings and specifications are complementary. What is called for in either is binding as if called for in both. In case of conflict within the drawings, specifications or between drawings and specifications the Architect/Engineer will select the method to be taken. Contractor shall have assumed prior to bid most expensive method is to be used and included in the bid.
- C. Take all working dimensions, device heights, door swings and the like from architectural drawings and check them against device locations or heights shown on the electrical drawings. In the event of conflict, report discrepancies to the Architect/Engineer for resolution before proceeding with the rough in work. Do not scale electrical drawings.
- D. Minor changes in the locations of raceways, devices and the like, from those shown on the plans, shall be made without extra charge if so directed by the Architect/ Engineer before installation.
- E. Motor horsepower and apparatus wattages indicated on the plans are estimated requirements of equipment furnished under other Divisions of this contract. Contractor shall review all approved equipment shop drawings prior to rough in. Advise the Architect/Engineer in writing of any deviations in actual equipment supplied affecting the electrical installation.

1.5 MANUFACTURERS' RECOMMENDATIONS

- A. Make all installations in strict accordance with manufacturers' published recommendations, approved shop drawings and details. All equipment and materials recommended by manufacturer shall be considered as part of this contract.

1.6 WORK RELATED TO OTHER DIVISIONS

A. TEMPORARY CONSTRUCTION POWER & LIGHTING

- 1. Arrange with the serving Utility (OHOP Mutual (253) 847-4363) for 120/240 Volt or 208Y/120 Volt service adjacent to construction site.
- 2. Contractor is responsible for all costs associated with setup and removal of the temporary construction equipment.
- 3. Provide, maintain and remove, when no longer required, temporary electrical construction wiring from the construction service meter to and within the building for the number of lights and receptacles required. Wiring to construction sheds, outdoor construction machinery, and temporary exterior work areas shall be the responsibility of individual contractors.

**NISQUALLY STATE PARK
NEW FULL SERVICE PARK - PHASE 2**

4. Provide construction lighting with portable wiring and temporary energization of the permanent building wiring, complete with lamps. Suitable construction lighting shall be provided in each room where lighting is required for any of the contractors on the job. See NEC ARTICLE 590. Temporary wiring.
5. Provide adequate feeders, circuit breakers and duplex 15-ampere 120-volt receptacles at locations as required. Note: 120 volt construction receptacles shall provide Ground Fault circuit protection in accordance with applicable WISHA safety standards.
6. Portable power cords from the outlets specified herein shall be the responsibility of individual contractors using the cords.
7. Responsibilities outlined in the Paragraph Temporary Construction Power and Lighting are delineated herein to avoid conflicts between the various contractors. Assume all responsibility for safety, Electrical and Safety Code compliance, performance and adequacy of the construction power and lighting installation. The Architect and Engineer assumes no responsibility for the performance or safety and will not inspect nor design this temporary installation as it is not part of the completed structure.

B. MECHANICAL CONTROL WIRING

1. See Division 23.

C. EQUIPMENT FURNISHED BY OTHERS

1. All electrical equipment furnished for this project shall be coordinated with the drawings to insure correctness of Voltage, Phase and Ampacity. Equipment served by single circuit or feeder shall be provided with appropriate internal wiring including fusing of multiple circuits.
2. Contractors supplying equipment incompatible with the designed electrical service voltage or phase shall be responsible for arranging and providing necessary changes in their supply wiring to suit the equipment.
3. Contractor prior to equipment rough-in shall verify (request approved shop drawings) dimensions of equipment to be furnished by others to insure correct clearances, connections and UL labeling.
4. Control Voltages shall not exceed 120 volts. Contractor supplying equipment shall provide control transformers for higher line voltages for connection by electrical contractor or equipment manufacturer. Control transformers shall be connected from phase to neutral.

1.7 SUPERVISION AND COORDINATION

- A. Coordinate work with local power (OHOP Mutual 253-847-4363), telephone, cable and data (Rainier Connect 253-683-4100) utilities to ensure compliance with their specific requirements. Before starting work, contact both power and communications utilities and make arrangement for their services to this project.
- B. Contact Washington State Labor and Industries Electrical Inspection. Obtain and pay for permit before starting work.
- C. Maintain adequate supervision of the Division 26 work and have a responsible person in charge at the site any time work is in progress or when necessary for coordination with other trades.

**NISQUALLY STATE PARK
NEW FULL SERVICE PARK - PHASE 2**

- D. Schedule work to best serve the interests of the Owner. Do not scale electrical drawings. Lay out work by referring to Civil, Landscape, Architectural, Structural, Mechanical and other Contractors to anticipate their movements. Cooperate with the other contractors on the job and coordinate work to avoid interference with them.
- E. Determine a satisfactory space allocation arrangement where electrical material is installed in proximity to work of other trades. No extra payments will be allowed to relocate work that interferes with that of other trades. Corrections shall be made at no cost to Owner.

1.8 CODES AND REGULATIONS

- A. All work shall conform to current applicable National, State and local Codes; these shall be regarded as the minimum standard of quality for material and workmanship. Contractor shall provide all Labor and Material required for compliance with Code Requirements or Code Interpretations, although not specifically detailed on the Drawings or in the Specifications. Contractor shall become familiar with all the following codes prior to bidding.

ASTM	American Society for Testing and Materials
NBFU	National Board of Fire Underwriters
NEC	National Electrical Code
WSNREC	Washington State Non-Residential Energy Code
NESC	National Electrical Safety Code
NEMA	National Electric Manufacturers Association
NFPA	National Fire Protection Association
UL	Underwriters Laboratories, Inc.
ICEA	Insulated Cable Engineers Associations
CBM	Certified Ballast Manufacturers
IBC	International Building Code
IFC	International Fire Code
ETL	Electrical Testing Laboratories
WAC	Washington State Administrative Code
---	Service Policies of the Serving Electrical Utility (OHOP Mutual) and Communications Company (Rainier Connect)

- B. Nothing in these Drawings and Specifications shall be construed as permitting work not conforming with governing codes.
- C. The Contractor shall not be relieved from complying with any requirements of these contract documents which may exceed, but not conflict with, requirements of the governing codes.
- D. Contractor shall include in bid all costs to have a Department of Labor & Industries approved firm to evaluate the installation safety, and compliance with code as required per WAC 296-40-100 for any equipment specified or furnished that is not UL labeled.
- E. For equipment furnished by others not UL labeled the electrical contractor shall not connect the equipment to the electrical system until receiving written approval by the electrical authority having jurisdiction.

**NISQUALLY STATE PARK
NEW FULL SERVICE PARK - PHASE 2**

1.9 PERMITS & FEES

- A. Obtain and pay all fees for licenses, permits and inspections required by laws, ordinances and rules governing work specified herein. Arrange for inspection of work and provide inspectors with all necessary assistance.
- B. New service connection fees for OHOP Mutual and Rainier Connect have been paid directly by Owner. Trenching, conduit, vaults, handholes indicated on the drawings and work associated with these systems are the responsibility of the Contractor and shall be included in the bid. Coordinate and schedule medium voltage cable, padmount transformer, meter installation and connections with OHOP Mutual.

1.10 WORKMANSHIP

- A. All work shall be done by competent craftsmen skilled in the specific work to be done. Equipment shall be installed in a neat and workmanlike manner following the best practice of the trade.

1.11 COST BREAKDOWN

- A. Furnish cost breakdown for electrical in the Schedule of Values.

1.12 OPERATING INSTRUCTIONS

- A. Fully instruct the Owner's designated representatives in the operation and maintenance of all components of the electrical system upon completion of the work and after all tests and final inspection(s) by the Authority(s) Having Jurisdiction.
- B. Provide scheduled instruction as follows:
 - 1. Lighting Control & Distribution System 1 hour
 - 2. Security Cameras 1 hour

All costs for contractor's instruction are to be included in the bid proposal. These costs are in addition to contractors' costs for commissioning required by the Washington State Non-Residential Energy Code for compliance.

- C. Instructors shall be contractor's superintendents or foreman knowledgeable in each system and equipment suppliers' representatives for special systems.

**NISQUALLY STATE PARK
NEW FULL SERVICE PARK - PHASE 2**

1.13 AS-BUILTS DRAWINGS

- A. Continuously maintain a set of as-built drawings to indicate all significant deviations from the original design and the actual placement of equipment and underground conduits. (Location of conduit stubouts shall be dimensioned from accepted reference lines). Changes shall be shown with red colored pencil while work is in progress. This "Record" set shall be clearly marked: "AS-BUILT DRAWINGS - Do Not Remove From Office."
- B. Final "CORRECTED AS-BUILT" electronic PDF (AutoCAD) shall be prepared by a competent drafter and provided electronically to the Engineer for review. Date, firm name, and drafter's name shall be included with title "AS-BUILT DRAWINGS" on each drawing. If there are no changes, drawing shall be marked "NO CHANGES, INSTALLATION PER PLAN."
- C. "AS-BUILT DRAWING" (Field Set) and "CORRECTED AS-BUILT DRAWINGS" (electronic PDF) via electronic transfer to the Engineer for transmittal to the Owner.

1.14 ELECTRICAL EQUIPMENT OPERATION AND MAINTENANCE (O&M) MANUALS

- A. Prepare electronic PDF copy of O & M manuals that contain operating and maintenance information, replacement parts list, shop drawings, wiring diagrams and equipment test data for all equipment and systems installed under this contract. Manuals shall be organized as follows:
 - 1. All information contained in the manuals shall be grouped by specification section categories. Manual shall be provided with a typewritten index identifying divider tabs to facilitate future references.
 - 2. Maintenance Information shall pertain to the exact equipment installed, not to the complete "line" of a manufacturer. Actual installed equipment shall be neatly and clearly identified on catalog sheets. All equipment in the O & M manuals shall be identified in exactly the same manner as installed and used in the contract documents.
 - 3. Parts list shall give original manufacturers ordering information. Parts information relabeled or renumbered by the equipment supplier will not be acceptable. The following information shall be provided as a minimum for each item:
 - a. Manufacturer's name, address and phone number.
 - b. Local supplier's name, address and phone number.
 - c. Complete parts lists including quantities and manufacturers part numbers.
 - d. Installation instructions.
 - e. Maintenance recommendations including maintenance procedure and recommended maintenance intervals listed in hours of operation, calendar units or similar time units.
 - 4. Shop drawings and wiring diagrams shall be complete for the specific system installed under the contract. "Typical" drawings and diagrams will not be acceptable unless properly marked to indicate the exact field installation. Equipment control diagrams shall be accompanied by written descriptions to familiarize maintenance personnel with proper equipment operation. Diagnostic "trouble-shooting" information shall be included where applicable.

**NISQUALLY STATE PARK
NEW FULL SERVICE PARK - PHASE 2**

5. Provide electrical equipment test data, as applicable, and for all motors according to Section 26 01 26 - "Maintenance Testing of Electrical Systems." Tabulation shall be in columnar format; equipment designations shall correspond to those used on installed identification nameplates.
6. Each O & M manual shall be assembled in a single electronic PDF file.
 - a. The cover shall have a typewritten label with the name of the Project, Owner, Electrical Engineer, Division 26 Contractor and year of completion.
7. Submit a preliminary electronic PDF copy, complete, for review and comments 20 days prior to completion of the project.
 - a. Deliver complete electronic PDF approved O & M manuals to the Engineer for transmittal to Owner at least 10 days prior to the specified scheduled instruction periods.

1.15 FINAL INSPECTION

- A. The electrical foreman or superintendent shall accompany the Engineer on the Final Inspection, and on any necessary Post-Final Inspections, to confirm all work has been satisfactorily completed.
- B. Defects and deficiencies found during this Final Inspection shall be corrected within 15 days of Contractor's receipt of Engineer's final punch list.

1.16 FINAL ACCEPTANCE

- A. These items are a prerequisite for final acceptance and payment:
 1. Electronic PDF of Electrical Equipment operation and Maintenance Manuals which will also include the items listed below.
 2. Certificates of Final Inspection
 - a) Electrical Inspector permit sign off
 - b) Fire Department permit sign off
 - c) Written statement the WSNREC lighting and controls commissioning requirements were complied with.
 3. Guarantee to Owner
 4. Motor and other test data
 5. Record drawings including "field" and "clean" sets.
- B. Satisfactory Final Inspection and Transmittal of these items to the Engineer will indicate the Contractor has fulfilled all the requirements of the project documents.

**NISQUALLY STATE PARK
NEW FULL SERVICE PARK - PHASE 2**

1.17 GUARANTEE

- A. The Division 26 Contractor shall provide written guarantee to repair or replace (without additional expense) any defective materials or workmanship which become evident within a period of one (1) year after final acceptance or for such longer period as elsewhere specified. All warranty work shall be to the satisfaction of the Owner.
- B. Any material guaranteed by a specific manufacturer for a period in excess of one year shall be specifically noted on the Owner's written guarantee. LED light fixtures shall be minimum 5 years including removal and installation labor.
- C. The Division 26 Contractor will not be expected to perform normal equipment maintenance, 60 days beyond date of Beneficial Occupancy by Owner or Final Acceptance, whichever date is earlier.

PART 2 - PRODUCTS

2.1 GENERAL

- A. All materials shall be new, free from defects, of the quality specified herein and on the drawings. Materials shall be designed to ensure satisfactory operation and rated life in the prevailing environmental conditions where installed. Materials shall be listed by Underwriter's Laboratories or a recognized testing laboratory for use under these conditions.
- B. Each type of material shall be of the same make and quality throughout the job. The materials furnished shall be the latest standard design products of manufacturers regularly engaged in their production.

2.2 TECHNICAL DATA

- A. Technical information contained herein relies entirely on tests and ratings provided by manufacturers who are solely responsible for their accuracy. The Engineer, by use of this information in no way implies the results of published manufacturer's information has been verified.

2.3 AS SPECIFIED EQUIPMENT

- A. This specification generally lists only one make and model number for each item of equipment or material required for the project. This is not intended to be restrictive but is intended to indicate the standard of quality, design and features required. In addition, the listed product is the basis of the design regarding physical size, electrical power requirements and performance. The product so identified is designated "as specified."

**NISQUALLY STATE PARK
NEW FULL SERVICE PARK - PHASE 2**

2.4 SUBSTITUTION OF MATERIALS

- A. Listing of approved materials is not intended to prevent acceptance of other materials provided the substitute products are submitted for approval and have been approved in accordance with the Substitution of Materials requirements.
- B. Substitute Equipment Requests prior to bid opening will not be considered.
- C. Approval Prior to Installation
 - 1. All substitution requests shall be made on the substitution request form.
 - 2. The Contractor shall be responsible for a substitute item suiting the space limitations shown and for any additional installation costs incurred by the substitution.
 - 3. Approval of substitute materials shall not be construed as authorizing any deviation from the contract drawings and specifications except where such deviation is clearly described in writing by the Contractor on the substitution request form and is approved in writing by the Engineer.
 - 4. Requests shall clearly define and describe the proposed substitute product. Such requests shall be accompanied by samples, record of performance, certified test reports and such additional information as the Engineer may require to satisfactorily evaluate the substitute product(s).
- D. Approval After Contract Award: Substitute products will be considered after contract award only under these conditions:
 - 1. Non-Availability of Specified Materials: The Contractor shall have placed orders for specified materials within ten days after notice to proceed and received written confirmation of non-availability from the supplier(s). The reason of non-availability shall be beyond the contractor's control such as: discontinuation of manufacture, strikes and acts of God.
 - 2. Contract Price Adjustments: The Contractor may submit substitution requests for Owner cost savings. All substitute request forms submitted after award of contract shall clearly indicate the proposed contract price change or the request will not be considered.
 - 3. Where Permitted in the Specifications: For items identified as "or equal". It shall be the contractors' responsibility to show that a substitute item is equal or superior in performance and quality to the specified item.
- E. No Substitute:
 - 1. It is the intent of this specification to require specific materials to be compatible with the existing installation. Certain materials and systems, consequently, are indicated "No Substitute" and shall be provided as specified.

**NISQUALLY STATE PARK
NEW FULL SERVICE PARK - PHASE 2**

2.5 COMPLETE SYSTEMS

- A. All systems specified herein and shown on the drawings shall be complete and operational in every detail. Mention of certain materials in bidding documents shall not be construed as releasing the Contractor from furnishing such additional materials and performing all labor required to provide a complete and operable system.

2.6 SUBMITTALS

A. Purpose of Submittals

1. Submittals processed by the Engineer are not change orders. The Contractor, by the submittal process, demonstrates an understanding of the design concept by indicating equipment and materials intended to be provided and fabrication/installation methods intended to be utilized to meet all requirements of the contract documents.
2. The Engineer's review is for general conformance with the design concept and the contract documents. Markings or comments shall not be construed as relieving the Contractor from compliance with the contract documents.

B. General Requirements: The Contractor shall provide electronic PDF submittal as follows:

1. Material Lists and Catalog Data: Submit, within 10 days after contract award, complete lists of materials, marked catalog sheets, dimensions and other information necessary to properly identify each item. Submittals shall include the most significant materials for each section of these Division 26 specifications.
2. Shop Drawings: Submit, within 20 days after contract award, shop drawings for equipment and materials unique to this installation.

C. Submittal items: Submittals shall include, but not be limited to the following items:

Raceways	Disconnects
Switchboards	Fused Disconnects
Panels	Fire alarm
Fuses	Nameplates
Wires and Cables	Time Switch
Wiring Devices	Data Cat 6 Cabling
Lighting Fixtures	Data Fiber Optic Cabling
Lighting Standards & Poles	Security Cameras
Lighting Control	3 Cell Inner Duct
Pre-cast Concrete Vaults/Covers	Items Requested by Engineer
Pre-cast Concrete Handholes/Covers	

D. Submittal Format

1. A transmittal letter with reference identification (i.e., Electrical Submittal No. 1, material lists and catalog data, etc.) shall accompany all submittals.

**NISQUALLY STATE PARK
NEW FULL SERVICE PARK - PHASE 2**

2. Submittal brochures shall be separately combined in electronic PDF format. Provide typewritten identification labels on each cover that include Project Name, Electrical Submittal Reference and Contractor's Name.
 3. All information contained in the submittal shall be grouped by specification sections. Provide a typewritten index and identifying sections for all project submittal items to facilitate future reference.
- E. Submittal Completeness
1. The Contractor shall make every effort to ensure the completeness of the initial submittal. Availability of certain shop drawings and catalog materials, however, may prevent this. Submittal shall not be delayed past specified time periods to await delivery of the missing items. The Contractor, instead, shall identify missing items on the transmittal letter and provide index listings and divider tabs for later insertion of these materials into the completed submittal brochure.
 2. Contractor shall state as part of the submittal, the contractor has responded to all vendor questions and contractor has reviewed each item of equipment for compliance with contract drawings and specifications.
- F. Engineer's Selection of Materials for Installation: The Engineer may select specified items that the Contractor shall provide, without change in contract price or time of completeness, under these circumstances:
1. Late and/or Unqualified Partial Submittals: Submittals must be made within the specified time periods; all partial submittals shall indicate manufacturer(s) catalog numbers, pertinent technical information and status of missing items.
 2. Failure to follow Re-submittal Procedures: Contractor, within 14 days after the Engineer rejects any items, shall re-submit new materials for approval.
 3. Materials have been submitted and rejected twice by the Engineer.
- G. Contractor's Responsibilities: The Contractor is responsible for all submittal details, accuracy of quantities and dimensions, selection of fabrication processes and techniques of assembly.
1. The Contractor shall furnish equipment/material suppliers with all Drawings and Specifications pertinent to their work.
 2. The Contractor shall review and sign all submittals and shop drawings, prior to submitting shop drawings to the Engineer for review. Contractor shall correct shop drawings and catalog data to ensure compliance with the specifications and drawings prior to initial submittal to Engineer for review. Obtain Engineer's written approval before ordering equipment or manufacture is started on any special equipment.
 3. Deviation from Shop Drawings in fabrication and/or installation of equipment is not permitted unless proposed changes are clearly noted in writing by the Contractor and approved in writing by the Architect/Engineer at the time of submittal.
 4. Maintain at least one complete approved submittal brochure on the jobsite for reference during construction.

**NISQUALLY STATE PARK
NEW FULL SERVICE PARK - PHASE 2**

2.7 ELECTRICAL EQUIPMENT IDENTIFICATION

A. General: These items shall be provided with nameplates:

1. All motors, motor starters, pushbutton stations, control panels and time switches.
2. Disconnect switches, switchboards, panelboards, time clocks, low voltage control panels and circuit breakers, contactors, and relays in separate enclosures.
3. Wall switches controlling receptacles, lighting fixtures or equipment where the receptacles are not located within sight of the controlling switch.
4. Special systems shall be properly identified at outlets, junction and pull boxes, terminal cabinets and equipment racks.

B. Nameplate Inscription

1. All nameplates shall adequately describe the function or operation of the identified equipment as required.
2. Panelboard and Switchgear nameplates shall include equipment designation, voltage and phase of supply, i.e., Panel A, 208/120V, 3 phase, 4 wire. Switchgear nameplate shall include Contractor, Engineer, date and AIC rating of switchboard.
3. Nameplate designations shall be consistent for all components of a particular piece of equipment, such as starter, disconnect switch, Push Button control station(s) and the like.
4. Contractor shall submit a complete list of nameplates for approval.

C. Nameplate Construction

1. Nameplates shall be laminated phenolic plastic with minimum 3/16" high black engraved characters on white background (alternate background colors shall be provided as noted in the specifications or drawings for special applications).
2. Nameplates shall be securely fastened to the equipment with No. 4 round-head phillips, cadmium plated steel, self-tapping screws. Contact cement adhesive only is not acceptable.
3. Motor nameplates may be non-ferrous die-stamped metal, minimum 0.03 inch thick, in lieu of separate phenolic nameplate. Device plates may be identified by engraving directly on the plate. All engraved or stamped lettering shall be filled with contrasting enamel.

PART 3 - EXECUTION

3.1 PROTECTION OF WORK

- A. Protect all work, wire, cable, materials and equipment installed under this division against damage by other trades, weather conditions or any other causes. Equipment found damaged or in other than new condition will be rejected as defective.

**NISQUALLY STATE PARK
NEW FULL SERVICE PARK - PHASE 2**

- B. Switchgear, panels, light fixtures, conduits, vaults, handholes and electrical equipment shall be kept covered or enclosed to exclude moisture, dust, dirt, plaster, cement, or paint and shall be free of all such contamination before acceptance. Enclosures and trims shall be in new condition, free of rust, scratches or other finish defects. Properly refinish in a manner acceptable to the Engineer if damaged.
- C. Keep conduit and raceways closed with suitable manufactured plugs or caps during construction to prevent entrance of dirt, moisture, concrete or foreign objects. Raceways shall be clean and dry before installation of wire and at the time of acceptance. Proof all raceways with a properly sized mandrel prior to installation of wire.
- D. Make up and insulate wiring promptly after installation of conductors. Wire shall not be pulled-in until raceways are complete, all bushings are installed, and raceway terminations are completed. Wire shall not be pulled into conduit embedded in concrete until after the concrete is placed and forms are removed.

3.2 EXISTING CONDITIONS

- A. Examine the structure, building, and conditions under which Division 26 work is to be installed for conditions detrimental to proper and timely completion of the work. Do not proceed with work until deficiencies encountered in installation have been corrected. Report any delay or difficulties encountered in installation of Division 26 work which might be unsuitable to connect with work by other Divisions in this specification. Failure to report conditions shall constitute acceptance of other work as being fit and proper for the installation of Division 26 work.

3.3 CUTTING AND PATCHING

- A. Obtain permission from the Architect/Engineer prior to cutting. Locate cuttings to not weaken structural components. Cut carefully and only the minimum amount necessary. Cut concrete with diamond core drills or saws except where space limitations prevent the use of such equipment.
- B. Penetrations of fire rated elements shall be carefully made to main fire that rating after the installation is complete.
- C. All construction materials damaged or cut into during the installation of Division 26 work must be repaired or replaced with materials of like kind and quality as original materials by skilled labor experienced in that particular building trade.

3.4 EXCAVATIONS

- A. The contractor shall be fully responsible for the location and protection of all existing utilities. The contractor shall verify all utility locations prior to construction by calling the underground locate line at 1-800-424-5555 a minimum of 48 hours prior to any excavation. The contractor will also be responsible for maintaining all locate marks once the utilities have been located.

**NISQUALLY STATE PARK
NEW FULL SERVICE PARK - PHASE 2**

- B. All excavations are to be so conducted that no walls or footings shall be disturbed or injured in any way.
- C. Remove all surplus earth not needed for backfilling and dispose of same as appropriate at a licensed disposal facility.

3.5 PAINTING

- A. Painting in general will be covered under another Division of this specification. Items furnished under this Division scratched or marred in shipment or installation are to be refinished by the Contractor to the satisfaction of the Engineer.

3.6 CLEAN UP

- A. Contractor shall continually remove debris, cuttings, crates, cartons, etc., created by work. Such clean up shall be done at sufficient frequency to minimize hazard to the public, other workmen, the building and the Owner's employees. Before acceptance of the installation, Contractor shall carefully clean switchboard, panels, vaults, handholes, wiring devices, coverplates, etc., to remove dirt, cuttings, paint, plaster, mortar, concrete, etc. Blemishes to finished surfaces or apparatus shall be removed and new finish equal to the original applies.

3.7 LABELING

- A. Clearly and properly label the complete electrical system, as specified herein, to indicate the loads served or the function of each item of equipment connected under this contract.
- B. Control circuits shall utilize combinations of colors with each conductor identified throughout using wrap around numbers or letters. Identification shall be consistent with the contract drawing requirements and operation and maintenance shop drawings.

3.8 MECHANICAL EQUIPMENT CONNECTIONS

- A. Provide complete electrical connections for all items of equipment, including incidental wiring, materials, devices and labor necessary for a finished working installation.

**NISQUALLY STATE PARK
NEW FULL SERVICE PARK - PHASE 2**

B. Mechanical/Electrical equipment connection coordination shall be as follows:

ITEM	FURNISHED BY	INSTALLED BY	POWER WIRING BY	CONTROL WIRING BY
Mechanical Equipment Motors	MC	MC	EC	--
Fused & Unfused Disconnect Switches, Thermal Overload & Heaters	EC	EC	EC	--
Motor Starter & Overload Heaters	MC	EC	EC	MC
Manual Operating & Speed Switches	MC	EC	EC	EC
Control Relays & Control Transformers	MC	MC	EC	MC
Low Voltage Thermostats	MC	MC	EC	MC
Line Voltage Thermostats Specified In Division 26	EC	EC	EC	EC
Temperature Control Panels	MC	MC	EC	MC
DDC Panels	MC	MC	EC	MC
Motor & Solenoid Valves, Damper Motors, PE & EP Switches	MC	MC	--	MC
Fire/Smoke Dampers (Actuators)	MC	MC	EC	MC/EC*
Duct-Mounted Smoke Detectors	EC/MC**	MC	--	MC/EC*

MC = Division 23

EC = Division 26

* Motor interlock by MC, Fire Alarm System Interconnection by EC.

** When there is no building fire alarm system present in the project.

**NISQUALLY STATE PARK
NEW FULL SERVICE PARK - PHASE 2**

3.9 SUPPORT AND ALIGNMENT

- A. Each fastening device and support for electrical equipment, fixtures, panels, outlets and cabinets shall be capable of supporting not less than four times the ultimate weight of the objects fastened to or suspended from the building structure.
- B. Install panels, cabinets and equipment level, plumb, and parallel with structural building lines. Switchgear, panels and all electrical enclosures shall fit neatly without gaps, openings or distortion. Properly and neatly close all unused openings with approved devices. Switchgear shall be seismically braced to building structure.
- C. Fit surface panels, devices and receptacles with neat, appropriate trims, plates or covers, (without over-hanging edges, protruding corners or raw edges) to leave a finished appearance.
- D. All junction boxes, pull boxes or other conduit terminating housings located above a suspended ceiling shall be securely suspended from structure or ceiling grid system to prevent sagging or swaying.

3.10 NOISE CONTROL

- A. Back-to-back or straight-through installation of wall or partition boxes is not permitted to minimize noise transmission between occupied spaces.
- B. Contactors, transformers, starters and similar noise producing devices shall not be placed on walls which are common to occupied spaces. Where such devices must be mounted on walls common to occupied spaces, they shall be shock mounted or isolated in such a manner as to effectively prevent the transmission of their inherent noise to the occupied space.
- C. Ballasts, contactors, starters, transformers and like equipment which are found to be noticeably noisier than other similar equipment on the project will be deemed defective and shall be replaced.

END OF SECTION

**NISQUALLY STATE PARK
NEW FULL SERVICE PARK - PHASE 2**

SECTION 260519 - LOW VOLTAGE ELECTRICAL POWER CONDUCTORS AND CABLES

PART 1 - GENERAL

1.1 WORK INCLUDED

- A. Bidding documents including Division 00 General Conditions, Published Addenda and related work in other Divisions form an integral part of these Specifications and shall be binding on the Division 26 Contractor for all work performed under Division 26, Electrical
- B. Provide all wire, cable and terminations for a complete installation.

PART 2 - PRODUCTS

2.1 PACKAGING

- A. Conductors shall be delivered to the job site in approved original cartons, or on reels as recommended by the manufacturer, and shall bear the Underwriter's Label. Reels shall be provided with suitable protection to prevent fork-lift damage to conductors during shipment or storage prior to use.

2.2 SPECIALIZED CONDUCTORS

- A. Conductors for specialized systems shall be as recommended by the equipment manufacturer.

2.3 CONDUCTORS - 600 VOLTS

- A. Stranded copper, insulated for 600 volts.
- B. Insulation types THW, THHN, THWN, XHHW, RHH, RHW, or as required to suit installation conditions.
- C. Aluminum: Stranded electrical grade, insulated for 600 volts. See installation section for permitted use.

2.4 CONNECTORS - 600 Volts

- A. Branch circuit conductor splices:
Pre-insulated "twist-on" type or "crimped-on" type as approved (Scotch-lok, Ideal or equal).
- B. Cable Splices:
Split-bolt or tool applied sleeves with pre-formed insulated cover, heat shrinkable tubing or approved plastic insulating tape.

**NISQUALLY STATE PARK
NEW FULL SERVICE PARK - PHASE 2**

- C. Terminator lugs of No. 12 wire and smaller:
Spade, insulated type to be tool applied.
- D. Terminator lugs for No. 10 wire or larger:
Two bolt (or approved positive restraint), tool applied compression type (Burndy or equal).

2.5 INSULATING MATERIALS

- A. Insulating tape or heat shrink tubing shall have the equivalent rating of the applicable conductor insulation (Scotch 3M, RAYCHEM or equal).

2.6 PLASTIC CABLE TIES

- A. Nylon, or equivalent, locking type (T&B or equal).

PART 3 - EXECUTION

3.1 GENERAL

- A. Install all wiring in raceway.

3.2 MINIMUM WIRE SIZE

Lighting and Power System No. 12 AWG
Fire Alarm Line Voltage Wiring No. 14 AWG
Low Voltage Wiring As recommended by Mfg

3.3 CONDUCTOR TYPES, REFERENCED ON PLAN

- A. Conductors shall be copper.
- B. Aluminum may be substituted for copper conductors size #0 and larger unless specifically noted as copper only on the drawings. All ground conductors shall be copper. Comply with 3.04 below.

3.4 ALUMINUM CONDUCTORS

When applicable or called for on drawings are subject to the following requirements:

- A. Increase wire size for same current capacity as copper. Increased conduit size as necessary for code compliance.
- B. Minimum size of aluminum conductors where use of aluminum is allowed shall be #1/0 AWG.

**NISQUALLY STATE PARK
NEW FULL SERVICE PARK - PHASE 2**

- C. Insulation requirements are the same as for copper conductor wires and cables.

3.5 CONDUCTOR COLORING CODE

Conductor color coding shall be as follows:

- A. 208/120 volt system
 - A Phase - Black
 - B Phase - Red
 - C Phase - Blue
 - Neutral – White
 - Grounding – Green
 - Switched wires – Other colors
- B. Conductors shall have colored insulation except wires larger than #8 may be black with colored tape identification at all terminations and splices.
- C. Additional colors may be used where such colors will help in identifying wires and different systems.

3.6 CONDUCTOR INSTALLATION

- A. Raceways shall be complete, clean and free of burrs before pulling conductors.
- B. U.L. approved pulling compounds may be used with the residue cleaned from the conductors and raceway entrances after the pull is made.
- C. Contractor shall obtain the manufacturer's published recommendations for the handling, pulling and terminating of the cable. Contractor shall perform work in accord with manufacturer's recommendations and accept all responsibility for work not in accord with manufacturer's recommendations.
- D. Pulleys or blocks shall be used for alignment of the conductors when pulling. Pulling shall be in accordance with manufacturer's specifications regarding pulling tensions, bending radius of the cable and compounds. No mechanical pulling means shall be used for wires No. 8 AWG and smaller. Cables shall be pulled by the conductor, not by the insulation or shielding.

3.7 MOISTURE PROTECTION

- A. Cable ends shall be protected at all times from moisture. Provide approved heat-shrink end caps or equivalent for all unterminated cable ends.

3.8 CONDUCTORS IN PANELS AND SWITCHBOARDS

- A. Conductors in panels, switchboards and terminal cabinets shall be neatly grouped and formed in a manner to "fan" into terminals with regular spacing.

**NISQUALLY STATE PARK
NEW FULL SERVICE PARK - PHASE 2**

3.9 CABLE SUPPORTS

- A. Provide conductor support devices as required by code in vertical cable runs.

3.10 INSULATION REMOVAL

- A. Insulation shall be removed with approved wire stripping tools. Conductors that are nicked or ringed are unacceptable and shall be cut off and re-stripped.

3.11 INSULATION OF ENERGIZED TERMINATIONS

- A. Insulate all exposed energized connections and splices with approved tape or heat shrink tubing. Tape, if used, shall be half-lapped in two directions.

3.12 TERMINATIONS - COPPER CONDUCTORS 600 VOLTS

- A. Control and special systems wires shall be terminated with a crimped on lug when terminating at a screw connection.
- B. All screw and bolt type connectors shall be made up tight and retightened after an eight hour period. Tighten all bolted connections with a ratcheting type torque wrench per manufacturer's standards.
- C. All tool applied crimped connectors shall be applied per manufacturer's recommendations and physically checked for tightness.

3.13 TERMINATION - ALUMINUM CONDUCTORS 600 VOLTS

- A. Aluminum conductors shall be terminated or spliced using hydraulic crimped aluminum lugs filled with a contact aid compound (Penetrox A or equal). They shall not be terminated or spliced with bolted pressure fittings. Where a device is available with bolted lugs only, a short length of copper conductor may be spliced to the aluminum conductor and the copper connected to the bolted pressure lug. A special type crimped aluminum lug with aluminum or copper "finger" manufactured for this purpose may be used.
- B. Hydraulic crimped fittings shall be sized for the conductor used and shall be made with a tool which assures a preset deformation before release.
- C. Aluminum lugs shall be plated.
- D. Provide Belleville washer system where bolting to aluminum lugs or bus unless specifically permitted otherwise. (Belleville washer bearing on a chrome plated or stainless steel washer.)

**NISQUALLY STATE PARK
NEW FULL SERVICE PARK - PHASE 2**

- E. Because aluminum oxidizes rapidly, and aluminum oxide is an insulator, contractor shall prepare aluminum wire for terminations by cleaning it with a wire brush immediately before inserting it into aluminum lugs.

END OF SECTION

**NISQUALLY STATE PARK
NEW FULL SERVICE PARK - PHASE 2**

SECTION 260526 - GROUNDING AND BONDING OF ELECTRICAL SYSTEMS

PART 1 - GENERAL

1.1 WORK INCLUDED

- A. Bidding documents including Division 1 General Conditions, Published Addenda and related work in other Divisions form an integral part of these Specifications and shall be binding on the Division 26 Contractor for all work performed under Division 26, Electrical.
- B. Provide a complete grounding system that complies with the current edition of the National Electrical Code (NEC), and all applicable regulatory codes.

PART 2 - PRODUCTS

2.1 GROUND RODS

- A. Minimum size: 3/4" diameter by 10'-0" long, copper clad steel rods.

2.2 GROUND CONDUCTORS

- A. Grounding conductors shall be soft drawn, bare, stranded copper unless otherwise noted. Size as shown on the plans and per the National Electrical Code (NEC) Article 250.
 - 1. GROUNDING ELECTRODE CONDUCTORS FOR A.C. SYSTEMS: See NEC table 250.66.
 - 2. EQUIPMENT GROUNDING CONDUCTORS:
See NEC table 250.122.
Equipment grounding conductors may be insulated; provide green insulation and/or approved permanent identification for conductors larger than No. 6 AWG.

2.3 GROUND ELECTRODE CONNECTORS

- A. Connectors for grounding electrode conductor to ground rod shall be of the thermal fusion type; conductor-to-conductor connections may be either thermal fusion or approved hydraulically applied compression type.

2.4 GROUNDING BUSHINGS

- A. Grounding bushings shall be matched to the ampacity of the grounding conductor and shall have approved set-screw type grounding lug connectors.

**NISQUALLY STATE PARK
NEW FULL SERVICE PARK - PHASE 2**

2.5 GROUNDING CONNECTORS

- A. Shall meet the requirements of ground bushings, cast, set-screw or bolted type.

2.6 GROUNDING CLAMPS

- A. Clamps shall be matched to the ampacity of the grounding conductor. Provide approved raceway hub where grounding conductor is shown protected by conduit or armored cable. Clamps shall be U-bolt type for connection to waterpipes.

PART 3 - EXECUTION

3.1 GROUND CONTINUITY

- A. Maintain ground continuity throughout the entire electrical system.
- B. Permanently connect the electrical system neutral to the water service. The system shall be grounded only at transformer secondaries and at the main distribution board. Branch panel neutrals must be isolated from additional points of grounding.
- C. Provide approved grounding bushings or locknuts on all conduits terminating in panelboards, pullboxes or other enclosures to ensure continuity of conduit grounding connections.
- D. Securely ground lighting fixtures via the conduit system or by a separate suitable grounding conductor where flexible conduit is used.
- E. Provide a separate grounding conductor in all non-metallic conduits and in all flexible metallic conduit runs. Connect to the grounding system in an approved manner.
- F. All plug-in receptacles shall be bonded to the box and raceway ground system.
- G. Provide a ground conductor in all drop cords and properly connect to grounding type wiring devices or equipment

3.2 GROUNDING CONNECTIONS

- A. All grounding connections shall be carefully made to insure low system impedance. Locate grounding connections to allow future servicing and expansion.

3.3 PREPARATION

- A. Prior to making mechanical or thermal connections, all conductors shall be clean, dry and bright with the bonding surface thoroughly cleaned of any oxides, mill, scale or other foreign matter.

**NISQUALLY STATE PARK
NEW FULL SERVICE PARK - PHASE 2**

3.4 PROTECTION

- A. Ground conductors shall be protected from mechanical injury during construction. Provide protective coverings or rigid non-ferrous conduit.

3.5 GROUND RODS

- A. Ground rods shall be driven into undisturbed soil to full depth. Provide additional rods, ionic salt solutions and the like where special low-resistant grounds are specified.

3.6 CONCEALED GROUND ELECTRODE SYSTEM

- A. Concealed ground electrode systems shall be installed, inspected, tested and certified for low resistance connections and low resistance to earth ground prior to being covered.

3.7 THROUGH-SLAB GROUND PENETRATIONS

- A. Ground conductors extending through the slab shall be protected by a rigid conduit sleeve; the void portion of the sleeve shall be packed with a non-hardening type duct seal.

3.8 TESTING

- A. Shall conform to Section 26 01 26 Maintenance Testing for Electrical Systems.

END OF SECTION

**NISQUALLY STATE PARK
NEW FULL SERVICE PARK - PHASE 2**

SECTION 260533 - RACEWAY AND BOXES FOR ELECTRICAL SYSTEMS

PART 1 - GENERAL

1.1 WORK INCLUDED

- A. Bidding documents including Division 00 General Conditions, Published Addenda and related work in other Divisions form an integral part of these Specifications and shall be binding on the Division 26 Contractor for all work performed under Division 26, Electrical.
- B. Provide all raceways for a complete electrical system. Include all fittings, hangers and appurtenances required for a complete installation.
- C. Provide outlet and pull boxes required to enclose devices, permit pulling conductors, for wire splices and branching.

PART 2 - PRODUCTS

2.1 GENERAL

- A. Provide boxes suitable for the location. Boxes shall meet NEMA Standards for various types.

2.2 CONDUITS

- A. Galvanized Rigid Steel, thick wall (GRS)
- B. Intermediate Metal Conduit (IMC)
- C. Electrical Metallic Tubing (EMT)
- D. Flexible Aluminum Metal Clad (MC) Armored Cable with ground wire with and without polyvinyl chloride jacket
- E. Non-metallic, polyvinyl chloride (PVC), schedule 40. Use schedule 80 under roadways.

2.3 FITTINGS

- A. GRS and IMC couplings and connectors shall have threaded connections. Galvanized malleable iron or non-corrosive alloy compatible with galvanized conduit. Running thread or set screw type fittings are not permitted.
- B. EMT - Couplings and connectors shall be rain tight, steel or malleable iron, utilizing a split corrugated compression ring and tightening nut or stainless-steel locking disk. Set screw fittings are permitted in dry locations. Set screw fittings are not permitted in wet locations or in concrete. Zinc, pot metal, die cast fittings and indenter fittings are not acceptable.

**NISQUALLY STATE PARK
NEW FULL SERVICE PARK - PHASE 2**

- C. Flexible Metal Conduit
 - 1. Dry Locations: malleable iron or steel, Thomas & Betts "Squeeze" type or equal.
 - 2. Damp or Wet Locations: Thomas & Betts "Super Liquid-Tight" with external ground lug.
- D. PVC Fittings shall be solvent welded types.
- E. Sealoff fittings shall be with filler fiber, poured compound and removable cover.
- F. Expansion Couplings shall be O.Z. type EX with ground jumper.

2.4 INTERIOR WIRING, NEMA 1

- A. Flush and concealed outlet boxes shall be galvanized stamped steel with screw ears, knock-out plugs, mounting holes, and fixture stud.
- B. Surface outlet boxes shall be galvanized stamped steel same as above for use on ceilings and in accessible locations. Contractor shall provide cast iron galvanized for use on walls below 8 feet.
- C. Boxes exceeding 4-11/16 inches square shall be welded steel construction with screw cover and factory painted.
- D. Surface Metal Raceway boxes shall be of same manufacture to match raceway. Boxes shall accommodate standard devices and device plates.
- E. Boxes for casting in concrete or mounting in masonry walls shall be galvanized steel (not aluminum or zinc die castings), specifically designed and listed for that purpose.

2.5 SPECIAL LOCATIONS

- A. For outdoor equipment where a drain is appropriate provide NEMA 3R boxes.
- B. For outdoor locations requiring dust and water protection provide NEMA 4 or 4X boxes.
- C. For hazardous locations, provide boxes rated for the class and division, as defined in the National Electrical Code.

2.6 BELOW GRADE

- A. Where exposed to earth, boxes (handholes or vaults) shall be constructed of precast concrete with hinged and locking cover. Structural loading shall be minimum H25 traffic rating. Provide stamped or welded bead labels (ID same as drawings) on lid and lid frame.

**NISQUALLY STATE PARK
NEW FULL SERVICE PARK - PHASE 2**

PART 3 - EXECUTION

3.1 GENERAL

- A. Install raceways concealed in construction of finished spaces.
- B. Cut conduit ends square, ream smooth and extend maximum distance into all couplings and connectors.
- C. Provide and install manufactured end caps on all conduit ends during construction to prevent the entrance of water or dirt. Tape, as a cover, is not acceptable.
- D. Pull a properly sized mandrel through each conduit prior to installation of conductors or pull-lines to remove any materials trapped within the conduit run.
- E. All PVC elbows shall be factory made.
- F. Field made elbows are acceptable for steel conduits when made with approved bending tools. Bends that show conduit flattened or deformation are unacceptable and shall be replaced.
- G. Conduits shall maintain a minimum 12" clearance from any high temperature surface.
- H. The conduit layout shall be carefully planned by the contractor to ensure neat and workmanlike installation. Conduit runs shall be parallel and perpendicular to building structure.
- I. Any work showing inadequate planning may be ordered removed by the Architect/Engineer and shall be replaced in a neat and proper manner at no additional cost to the owner.

3.2 CONDUIT SIZING

- A. Conduits shall be sized per code for conductors with type THW insulation, although thinner insulation types are permitted in some cases. Conduit size shall not be reduced if large size is specified on the drawing. Minimum interior conduit size shall be ¾" trade diameter. Interior conduit ½" trade diameter may be used for dead end receptacles and switch runs.
- B. Minimum exterior conduit size shall be 1" trade diameter.

3.3 GRS AND IMC

- A. Install GRS or IMC for all conduits in wet locations, concrete, underground, exposed to weather, hazardous locations, where subject to physical damage and as noted on drawings.
- B. Connections shall be watertight in damp locations.

**NISQUALLY STATE PARK
NEW FULL SERVICE PARK - PHASE 2**

3.4 EMT

- A. EMT may be installed for wiring in masonry block, frame construction, furred ceilings, above suspended ceilings and exposed dry location unfinished spaces not subject to physical damage. EMT shall not be installed underground, under concrete slabs-on-grade, in concrete slabs-on-grade, exposed to weather, on exterior of buildings or on roofs.
- B. Contractor shall coordinate assembly and installation of EMT in masonry block construction to avoid construction delays. Avoid surface cut masonry units wherever such masonry units are to remain unplastered or exposed.

3.5 FLEXIBLE CONDUIT AND METAL CLAD (MC) CABLE

- A. Provide flexible conduit connection to motors and equipment subject to vibration with at least a 60 degree loop to allow for isolation and flexibility. Use liquid-tight for pumps, equipment which is regularly washed down, and for equipment in damp locations. Provide bonding jumper as required by N.E.C.
- B. Metal clad cable with ground wire may be used for branch conduit wiring. Do not use for home runs to panels.

3.6 PVC CONDUIT

- A. PVC conduit may be used underground when permitted by code and where designated as an acceptable substitute for GRS or IMC on the drawings. Field bends, less than 45 degrees, when necessary, shall be formed with factory recommended heater. PVC bends 45 degrees or greater shall be factory made.

3.7 SURFACE METAL RACEWAY

- A. Install only in unfinished areas where conduits cannot be concealed in finished spaces. Install raceways parallel to a building surface, (i.e. wall, ceiling, floor) and fasten to the surface as recommended by the manufacturer. Mount exposed raceway in the least obvious location.

3.8 UNDERGROUND RACEWAYS

- A. Burial depth of underground raceways shall be not less than NEC minimums and shall be deeper where so noted herein or required to avoid conflicts.
- B. Arrange and slope conduits entering buildings to drain away from the point of entry.
- C. Conduits passing through the exterior walls below grade and/or bridging areas of naturally unstable soil conditions or previously filled areas shall be placed in a manner to avoid crushing from ground settlement. Backfill under conduit shall be thoroughly compacted. Provide approved 360 degree deflection fittings on conduits passing through seismic joint areas design to accept movement.

**NISQUALLY STATE PARK
NEW FULL SERVICE PARK - PHASE 2**

3.9 CONDUITS IN FOUNDATION AREA

- A. Conduits in foundation areas shall be installed so as not to undermine the footings. Check structural drawings for any specific instructions. Backfill over conduits under footings and concrete slabs shall conform to the requirements of the Architect/Structural Engineer.
- B. Conduits passing through conduit footings require approval by Structural Engineer.

3.10 STUBUPS THROUGH CONCRETE SLABS

- A. Conduits through concrete slabs shall be steel. Install at such depth so the exposed conduit is vertical and curved section of the elbow is below the concrete slab.

3.11 INSERTS AND SLEEVES

- A. Furnish and install all inserts and sleeves necessary for Division 26 installation prior to pouring of concrete slabs and walls.
- B. In existing concrete slabs and walls utilize drilled-in threaded inserts, installed as recommended by the manufacturer, where additional supports are required. Neatly core drill openings where additional sleeves are required.

3.12 SEALING RACEWAY PENETRATIONS

- A. Exterior Wall Surface Above Grade
For concrete construction above grade, cast raceway or sleeve in wall or core drill wall and hard pack with a mixture of equal parts of sand and cement. Seal around all penetrations, with caulking approved by Architect/ Engineer.
- B. Exterior Surface Below Grade
Cast raceway into wall/floor or use manufactured seal assembly cast in place. OZ type "FSK" or equal. Change from PVC to steel conduit (couplings or bushings) where necessary to obtain a watertight seal in poured concrete wall or floors.
- C. Roof
Conduits passing through building roof shall be flashed using a 4 lb. per square foot lead plumbing vent flashing extending not less than 10" from the conduit under the roofing, and not less than 10" above the roof around the conduit. Flashing shall be attached by an approved galvanized or stainless-steel clamping band.
- D. Fire Rated Construction
 - 1. All seals and products must meet with the approval of the local Fire Marshal.
 - 2. Concrete or Masonry
 - a. Seal around raceway with an approved firestop compound that passes UL test 1479 (ASTM E814) DOW CORNING 3-6548, T & B FLAME SAFE, 3M Fire Barrier Caulk, 3M #Fire Barrier Putty, or equal.

**NISQUALLY STATE PARK
NEW FULL SERVICE PARK - PHASE 2**

3. Plaster or Gypsum Wallboard
 - a. Seal around raceway penetration with plaster and approved fire tape.

E. Acoustical Sealing

1. Provide Acoustical Sealing of all wiring and raceway openings in ceilings, walls and floors which are critical barriers for noise transfer. Acoustical sealing shall consist of resilient caulking to seal all openings around wiring and electrical raceways.

3.13 SEALING CONDUITS

- A. Seal interior of all conduits which enter the building through floor, roof or outside walls and may carry water into the building. Seal on the end inside the building, using duct sealing mastic, non-hardening compound type, specifically designed for such service. Pack around wires in the conduit.
- B. For exterior wall penetrations below grade, install OZ type "CSB" sealing bushing at interior end of penetrating conduit. Threaded fittings-only are permitted in entering conduits ahead of the sealing bushing.
- C. Provide for water drainage away from building so no electrical problems will result if seals leak.

3.14 CONDUIT HANGERS

A. General

1. Provide for supporting all conduits from the building structure. Space supports per NEC. Contractor shall provide supports adequate for the loads and resistant to earthquake forces.
2. Contractor is responsible to calculate lbs/sq ft of proposed main conduit runs and verify with project structural engineer if acceptable or additional structural bracing is required. Contractor shall alter conduit route or provide additional bracing acceptable to the structural engineer.
3. Conduits shall be fastened with approved pipe straps or separate suspension hangers to ceiling metal inserts and/or structural members.

B. Hangers for Direct Mounted Conduits

1. Hangers attached directly to building surface shall be two hole sheet steel or one hole malleable iron, all galvanized, pipe clamps. (Thomas & Betts or approved equal).
2. Hangers for ground cable and PVC conduit supporting ground cable shall not encircle the cable or conduit in metal but shall be 2-hole plastic or 1-hole metal clamps.

C. Hangers for Single Suspended Conduit

1. Hangers suspended below ceilings shall utilize steel rods and malleable iron pipe rings sized for the application (Grinnell No. 97 or approved equal). Provide concrete hanger

**NISQUALLY STATE PARK
NEW FULL SERVICE PARK - PHASE 2**

inserts as required.

D. Trapeze Type Suspended Supports

1. Trapeze type supports shall be used where two or more conduits use the same routing. Such hangers shall utilize steel rods, structural steel channels, and clamps of Kindorf, Unistrut or approved equal, sized for the application.

E. Support of Conduit in Steel Stud Walls

1. Attach conduits to studs with approved straps or 18 gauge steel wire secured to steel bars.

3.15 CONTINUITY OF CONDUIT SYSTEM

- A. Conduits shall be assembled continuous and secured to boxes, panels, etc., with appropriate fittings to maintain electric continuity.

3.16 PULL-LINES

- A. Provide 150 pound plastic pull-lines in conduit-only systems and spare conduits to facilitate future conductor installation.

3.17 ANCHORING

- A. All interior boxes shall be firmly anchored directly or with concealed bracing to building studs or joints. Boxes must be so attached not "rock" or "shift" when devices are operated.
- B. Exterior boxes shall be fastened to approved hot dipped galvanized mounting supports and racking appropriate for size of enclosure.

3.18 FLUSH MOUNTING

- A. All boxes shall have front edge (box or plaster ring) even with the finished surface of the wall or ceiling. Use of long screws with spacers or shims will not be acceptable.

3.19 RECEPTACLES, SWITCHES, VOICE/DATA OUTLETS

- A. Coordinate the work of this Section with the work of other Sections and trades. Study all drawings that form a part of this contract and confer with the various trades involved to eliminate conflicts between the work of this Section and the work of other trades. Check and verify locations with respect to door swings, installation details, cabinet work, and suspended ceilings indicated on contract drawings. Review and coordinate locations of all plumbing, heating, and ventilating equipment and other equipment indicated on the contract drawings of all trades.
- B. Centered on Built-In Work: In the case of doors and cabinets, where devices are centered between two such features, rough-in these device locations exact. Relocate any devices which are located off center at no additional cost to the owner.

**NISQUALLY STATE PARK
MAINTENANCE BUILDING PHASE 1**

- C. Where more than one device is shown or specified to be at the same elevation or one above the other, align them exactly on centerlines horizontally or vertically. Relocate as directed all such devices including light switch receptacles, voice/data, signal and thermostat devices which are not so installed, at no additional cost to Owner.
- D. Device Outlet Height: Measure from the finished floor to the centerline, unless otherwise noted on electrical or architectural drawings, or required to serve specific equipment.

Switches	42 inches, set vertically
Receptacles	18 inches set vertically. 30 inches in shop and exterior to building
Voice/Data	18 inches, set vertically
Other	As shown on the plans or as directed by the Architect/Engineer

3.20 LIGHTING FIXTURES

- A. Locate in accordance with approved architectural ceiling layout plans. Notify Architect/Engineer of any conflicts between plans prior to rough-in. Contractor shall relocate light fixtures at no additional charge if field coordination is not done prior to installation.

3.21 ELECTRICAL WORK IN COUNTERBACKS, MILLWORK AND CASEWORK

- A. Provide templates, where required, to other trades for drilling and cutting to insure accurate location of electrical devices as field verified prior to rough-in with the Architect.

3.22 CONNECTION TO EQUIPMENT

- A. Provide device back boxes of size and at locations necessary to serve equipment furnished under this or other Divisions of the specifications or by others. A device box is required if equipment has pigtail wires for external connection, does not have space to accommodate circuit wiring or requires wire different from circuit wiring used. Study equipment details to assure proper coordination.

3.23 BLANK COVERS

- A. Provide blank cover or plate over all boxes.

END OF SECTION

**NISQUALLY STATE PARK
NEW FULL SERVICE PARK - PHASE 2**

SECTION 262413 - SWITCHBOARDS

PART 1 - GENERAL

1.1 WORK INCLUDED

- A. Bidding documents including Division 00 General Conditions, Published Addenda and related work in other Divisions form an integral part of these Specifications and shall be binding on the Division 26 Contractor for all work performed under Division 26, Electrical.
- B. Provide service entrance, main distribution switchboard non walk-in, fully gasketed Nema 3R equipment complete with accessories and continuous full load ampacities as indicated. Transient voltage surge suppression equipment shall be provided by the manufacturer integral to the switchboard.
- C. Provide metering compartment compatible with OHOP Mutual (serving utility) standards and requirements. Verify with OHOP Mutual as part of shop drawing approval.

PART 2 - PRODUCTS

2.1 ACCEPTABLE MANUFACTURERS

- A. General Electric
- B. Square D
- C. Cutler Hammer
- D. Siemens

2.2 ENCLOSURES

- A. General Description
 - 1. Switchgear shall be freestanding and utilize sectionalized construction to allow localized access without disturbing adjacent sections. Equipment shall be dead front type, Nema 3R, gasketed with non-walk-in doors.
- B. Enclosure Construction
 - 1. Enclosure shall be fabricated of code gauge steel; minimum 12 gauge, except front panels and doors may be 14-gauge minimum.
 - 2. Steel angle and/or channel framework shall be designed to provide the strength and rigidity required for the particular installation and shall be suitable for lifting support.

**NISQUALLY STATE PARK
NEW FULL SERVICE PARK - PHASE 2**

3. A removable lifting angle shall be provided at the top and bottom of each shipping section.
4. Enclosure shall be front access only.
5. Enclosure types shall generally be Nema 3R, gasketed for exterior applications with hinged and locking doors.
6. Finish: The paint finish shall be factory applied, standard gray color for all exterior and interior painted surfaces. Other colors may be considered.

2.3 SWITCHBOARD DIMENSIONS

- A. Overall height of switchboard shall not exceed 90 inches (not including base channels). Length and depth shall not exceed dimensions as scaled or noted in contract documents. Manufacturers whose equipment dimensions exceed those indicated shall notify the Contractor in writing prior to the bid date. The contractor's bid shall be based only on equipment which fully complies with the contract documents. The cost of building modifications, switchboard relocations (if permitted) and other additional work required to accommodate larger switchboard(s) than shown on the drawings shall be borne totally by the Contractor.

2.4 SWITCHBOARD BUSBARS

- A. Aluminum or copper at manufacturer's option, factory fabricated, carried to terminals for connection to service cables or busway. Brace switchboard components for symmetrical fault current shown plus asymmetrical offset (100,000 amp bracing minimum). Aluminum bus shall be tin plated over its full length.
- B. Busbar Joints and Connections:
 1. Busbar-to-busbar connections shall be lapped, bolted and silver or tin plates, to produce low contact resistance and low temperature rise joints. Aluminum bus joints shall utilize Grade 5 bolts with belleville washers.
 2. Overcurrent devices shall be bolted to busbars using Grade 5 bolts and belleville washers.
 3. Conductor connectors shall be bolted to busbars using Grade 5 bolts and belleville washers.
- C. System of Bussing shall be three phase, 4 wire, with full size neutral.
- D. Ground Bus shall be full-length ground bus bonded to frame. Minimum size shall conform to UL 891 for grounding neutral conductor.

2.5 SWITCHBOARD COMPONENTS

- A. Service entrance rated switchboard shall include (but not be limited to) the following:
 1. Shall conform to UL 869 and have a Service Entrance Type UL label.
 2. Shall be full fault current rated and properly coordinated with service overcurrent device.
 3. Shall contain Owner current transformers and instrumentation.

**NISQUALLY STATE PARK
NEW FULL SERVICE PARK - PHASE 2**

4. Shall have Transient Voltage Surge Suppressor (TVSS) equipment provided by switchgear manufacturer, mounted integral to the switchboard.1.
5. Provisions for utility company metering (OHOP Mutual.
6. Circuit breakers, size and quantity as shown.
7. Space provisions for future breakers as shown, including complete bussing and hardware for mounting devices.
8. Cleats for securing all conductors within the switchboard.
9. Miscellaneous appurtenances as required for a complete installation.

2.6 NAMEPLATES

- A. Provide engraved phenolic nameplates per Section 26 05 00, Common Work Results for Electrical Systems, for each switchboard, instrument, protective device and disconnect device for the entire switchboard lineup.
- B. Each protective device and disconnect nameplate shall include load designation (and fuse size and type when applicable). Furnish complete list with submittal.
 1. Provide one job nameplate on the main switchboard with the following information:
 - a. Project Name
 - b. Electrical Consultant (Cross Engineers)
 - c. Electrical Contractor
 - d. Year of Manufacture
 - e. UL Short Circuit Rating

2.7 RISER DIAGRAM

- A. Provide a complete electrical system riser diagram (as-built) that shows service entrance equipment, panelboards, raceway/feeder sizes and the like. Diagram shall utilize non-fading ink and paper and be mounted to the exterior of the main switchboard in a clear plastic front frame. Submit preliminary draft to project engineer for approval prior to final fabrication.

2.8 SHOP DRAWINGS

- A. Prepare and submit for review prior to manufacture. Include front view, dimensions, device sizes and layout, list of nameplates and all other information required to demonstrate conformance with contract documents.
- B. Fault current and Arc Flash study and labeling requirements.

**NISQUALLY STATE PARK
NEW FULL SERVICE PARK - PHASE 2**

PART 3 - EXECUTION

3.1 MOUNTING

- A. All switchboards shall be provided with 3,000 PSI, concrete housekeeping pad that is 3-1/2 " high and 4" larger (length and width) than the "footprint" of the equipment.
- B. Secure switchboard vertically and horizontally, to prevent overturning from earthquakes, with 1/2" x 8" minimum black mild steel foundation anchor J-bolts. Bolts shall be set in the sub-base decking and extend through the housekeeping pad with sufficient threads to attach the equipment. Provide horizontal stainless steel structural support to building structure. This project is seismic zone 3.

3.2 WIRING

- A. Shall conform to applicable sections of these specifications.
- B. Shall be secured to switchboard enclosure with cleats. Maximum spacing shall not exceed 24 inches.

3.3 SPACE

- A. Verify space available with equipment sizes and code required working clearances prior to submittal of shop drawings.

3.4 GROUNDING

- A. Provide per Section 26 05 26 Grounding and Bonding for Electrical Systems.

END OF SECTION

**NISQUALLY STATE PARK
NEW FULL SERVICE PARK - PHASE 2**

SECTION 262416 - PANELBOARDS

PART 1 - GENERAL

1.1 WORK INCLUDED

- A. Bidding documents including Division 00 General Conditions, Published Addenda and related work in other Divisions form an integral part of these Specifications and shall be binding on the Division 26 Contractor for all work performed under Division 26, Electrical.
- B. Provide all panelboard equipment complete. All equipment shall be dead front type construction and shall bear the U.L. label. Load centers will not be acceptable.
- C. All panels provided for service entrance locations as defined by the NEC shall be provided with a UL label as Suitable for Use as Service Entrance Equipment (SUSE).

1.2 SHOP DRAWINGS

- A. Prepare and submit for review prior to manufacture. Include front view, dimensions, device sizes and layout, list of nameplates and all other information required to demonstrate conformance with contract documents.
- B. Dimensions of panelboards shall not exceed those noted on or scaled from the contract documents.

PART 2 - PRODUCTS

2.1 ACCEPTABLE MANUFACTURERS

- A. Siemens
- B. General Electric
- C. Square D
- D. Cutler Hammer

2.2 PANELBOARD DESCRIPTION

- A. Voltage, arrangement, and capacity of bus and overcurrent protective devices shall be as shown on the drawings. Bus shall extend behind all spaces ready for future overcurrent protective devices.

**NISQUALLY STATE PARK
NEW FULL SERVICE PARK - PHASE 2**

- B. Buss bars shall be plated aluminum or copper with ampere density not-to-exceed 1200/1000 amperes per square inch. Bussing will generally be 3 phase, 4 wire, 100 percent neutral, braced to match the interrupting rating of the breakers.
- C. Provide multiple lugs where parallel or "feed-through" connections are shown on drawings.
- D. Provide separate neutral and ground buses at the bottom of each panelboard.

2.3 OVERCURRENT PROTECTIVE DEVICES

- A. Provide thermal-magnetic type circuit breakers.
- B. The AIC rating of the panel shall be as specified on the drawings.
- C. Mount breakers in all panelboards so breaker handles operate in a horizontal plane. Provide common trip on all multiple pole breakers.
- D. 120/208 volt circuit breakers shall be either plug-in or bolt-in type.
- E. Circuit Breakers rated 15A through 30A shall be U.L. rated for 60/75 degree centigrade wire. Breakers 35A and larger shall be rated for 75 degree centigrade.
- F. Circuit breakers intended for switching 120 volt loads shall be switching duty rated (SWD).

2.4 ENCLOSURE GENERAL CONSTRUCTION

- A. Provide cabinets of sufficient dimensions to allow future expansion and addition of overcurrent devices within the panelboards. All panelboards shall be provided with door-in-door construction. Provide increased enclosure width required for installation of conduits.
- B. Provide factory primer coat for cabinets located in finished areas. Where cabinets are located in unfinished areas, standard lacquer or enamel finish, gray or blue-gray color, shall be substituted for factory primer coat.
- C. All electrical distribution equipment locks shall be keyed identically.
- D. Fasten panelboard front with machine screws with oval counter-sunk heads, finish hardware quality, with escutcheons or approved trim clamps. Clamps accessible only when dead front door is open are acceptable.
- E. Surface mounted panelboards with fronts greater than 48 inches vertical dimension shall be hinged at right side in addition to hinged door over dead front. Provide three point latching mechanism with one T-handle operator.
- F. Provide matching trim of same height for adjacent panels or control devices in finished areas.
- G. Special remote control switches, contactors, current transformers, transducers or TVSS equipment where shown integral to a panelboard, shall be mounted on the same frame as the

**NISQUALLY STATE PARK
NEW FULL SERVICE PARK - PHASE 2**

panelboard interior. Provide screw retained access door in the dead front shield. A common enclosure door shall cover both special integral device(s) and panelboard overcurrent protective devices.

PART 3 - EXECUTION

3.1 GENERAL INSTALLATION

- A. Secure panelboards in place with top of cabinet at 6'-0", above finished grade unless otherwise noted. Top of cabinet and trim shall be level; trim and door shall fit neatly without gaps, openings or distortion.
- B. Top edges of adjacent panels shall be even.
- C. Securely anchor panelboards to structural framing or walls with approved fasteners and concealed bracing as required. Provide steel channel support framing where panelboard is free standing. Submit support rack shop drawings for approval prior to fabrication.
- D. Install panelboard interiors only after the building structure is completely enclosed.

3.2 CIRCUIT INDEX

- A. Each panelboard shall be provided with a typewritten index listing each circuit in the panel by number, with its proper designation. Listing shall match circuit breaker arrangements, typically with odd numbers on the left and even numbers on the right. Room numbers shall be the final room numbers used in the building as verified with the Owner. Mount index with a transparent protective cover inside the cabinet door.

3.3 PANELBOARD NAMEPLATE

- A. Provide phenolic engraved nameplate for each panelboard. See Section 26500 Common Work Results for Electrical Systems

3.4 SPACE

- A. Verify space available with equipment sizes and code required working clearances prior to submittal of shop drawings.

END OF SECTION

**NISQUALLY STATE PARK
NEW FULL SERVICE PARK – PHASE 2**

SECTION 265000 - LIGHTING

PART 1 - GENERAL

1.1 SUMMARY

- A. Bidding documents including Division 00 General Conditions, Published Addenda and related work in other Divisions form an integral part of these Specifications and shall be binding on the Division 26 Contractor for all work performed under Division 26, Electrical.
- B. This Section includes interior lighting fixtures, lighting fixtures mounted on exterior building surfaces, pole mounted lights, LED module, drivers, emergency lighting units, and accessories.
- C. Provide the lighting system complete and operational. All light fixtures shall be provided complete with LED module, mounting hardware and accessories required for operation.
- D. Provide lighting fixtures of types, sizes and finish as listed on the drawings. Light Fixtures shall be complete assemblies constructed to ensure full life of components and minimize amplification and transmission of component generated noise.
- E. Contractor shall include in the bid all costs and documentation for lighting control commissioning required by the Washington State Non-Residential Energy Code (WSNREC). Contractor shall provide the owner a complete report of test procedures and results indicating all lighting controls have been tested, adjusted and operate in accordance with approved plans and specifications per the authority having jurisdiction.
- F. Light fixture schedule series numbers are a design series reference and do not necessarily represent the exact catalog number, size, voltage, wattage, type of LED, driver, finish trim, ceiling type, mounting hardware, ceiling trim or special requirements as specified hereinafter or as required by the particular installation(s). Provide complete light fixtures and drivers to correspond with the number of LED's, wattage, switching and/or size specified. Refer to light fixture schedule, Architectural drawings, and schedules for additional requirements.
- G. Light fixture voltage shall match voltage of circuit serving the light fixture. Contractor as part of the submittal process shall verify ceiling type compatibility of each light fixture and notify engineer in writing of any conflicts.

1.2 REFERENCES

- A. Shall be as follows:
 - National Electrical Manufacturer's Association (NEMA):
LE 5-1993 Procedure for determining luminaire efficiency ratings.

1.3 QUALITY ASSURANCE

**NISQUALLY STATE PARK
NEW FULL SERVICE PARK – PHASE 2**

- A. Listing and Labeling: Provide light fixtures, emergency lighting units, and accessories Listed and Labeled as defined in NFPA 70, Article 100 and marked for intended use for the location and environment in which installed.
- B. Comply with NFPA 70, as adopted and administered by the Authority Having Jurisdiction.
- C. NFPA 101 Compliance: Comply with visibility and luminance requirements for exit signs.

1.4 SUBMITTALS

- A. Submittals shall be neatly and clearly marked to indicate the light fixture(s), LED module and drivers fully comply with contract documents. When substitute light fixtures are submitted (if permitted) the data shall clearly cross reference (written and highlighted) the substitute light fixture complies with every detail of the specified light fixture. Light fixtures not fully complying with contract documents are not permitted.
- B. Submittals shall have light fixture types and project name clearly indicated and shall be prepared by the authorized manufacturer's representative serving the project area. A list of manufacturer representatives (including address, telephone and fax numbers) identifying which light fixture types they represent shall be included with submittals. Submittals or requests for approval not meeting these requirements will be rejected.
- C. For light fixtures mounted in continuous rows, submit scaled drawings prepared by the light fixture manufacturer showing all details of construction, lengths of runs, weight pendant and power feed locations, accessory pieces, finishes method of field assembly and list of materials.

Contractor to provide manufacturer with accurate field dimensions where required.

- D. Product Data: For each type of lighting fixture indicated on the lighting fixture schedule, arranged in order of light fixture designation. Include data on features, accessories, and the following:
 - 1. Dimensions of light fixtures.
 - 2. Certified results of independent laboratory tests for light fixtures and LED module for electrical ratings and photometric data.
 - 3. Emergency lighting unit battery and charger.
 - 4. Types of LED's, color temperatures and (LPW) lumens per watt.
- E. Wiring Diagrams: Detail wiring for light fixtures that clearly differentiates between manufacturer-installed and field-installed wiring.
- F. Product Certificates: Signed by manufacturer(s) or their designated representatives stating lighting fixtures certifying that products comply with drawing and specification requirements.
- G. Dimming Driver Compatibility Certificates: Signed by manufacturer of driver certifying drivers are compatible with dimming systems and equipment with which dimming drivers are to be used.

1.5 SUBSTITUTIONS

**NISQUALLY STATE PARK
NEW FULL SERVICE PARK – PHASE 2**

- A. Lighting fixtures designated for this project are based on the light fixture types and manufacturers specified. If substitution of light fixtures other than those specified is proposed, Contractor shall submit highlighted product information for approval.
- B. Substitution requests shall include all information required under 1.04 SUBMITTALS of this section.

1.6 COORDINATION

- A. Lighting Fixtures, Mounting Hardware, and Trim: Coordinate layout and installation of lighting fixtures with ceiling system and other construction.

1.7 WARRANTY

- A. General Warranty: Special warranty specified in this section shall not deprive Owner of other rights Owner may have under other provisions of the Contract Documents and shall be in addition to and run concurrent with other warranties under requirements of the Contract Documents.
- B. Special Warranty Period for Batteries: Manufacturer's standard, but not less than 10 years from date of Substantial Completion. Full warranty shall apply for first year and prorated warranty for last nine years. Warranty shall include removal/installation labor and legal disposal by manufacturer.
- C. Special Warranties for LED Drivers: Written warranty, executed by manufacturer agreeing to replace LED drivers, including removal/installation labor for driver failure in materials or workmanship within specified warranty period.
- D. Light Fixtures Utilizing LED Lamp Technology: Provide manufacturer's warranty for a period of not less than 5 years including parts and labor for full replacement of defective product.

1.8 EXTRA MATERIALS

- A. Furnish extra materials described below to match product installed and packaged with protective covering for storage and identified with labels describing contents.
 - 1. Drivers: Provide 10% (minimum 1) of each type LED light fixture driver. Label each driver with fixture type as identified in O & M manual and on record drawings. Turn over to Owner at completion of project and obtain signed receipt.

PART 2 - PRODUCTS

2.1 LIGHTING FIXTURES AND LIGHTING FIXTURE COMPONENTS, GENERAL

- A. Metal Parts: Free from burrs, sharp corners, and edges.

**NISQUALLY STATE PARK
NEW FULL SERVICE PARK – PHASE 2**

- B. Sheet Metal Components: Steel, unless otherwise indicated. Form and support to prevent warping and sagging.
- C. Doors, Frames, and Other Internal Access: Smooth operating, free from light leakage under operating conditions, and arranged to permit re-lamping without use of tools. Arrange doors, frames, lenses, diffusers, and other pieces to prevent accidental falling during re-lamping and when secured in operating position.
- D. Reflecting Surfaces: Minimum reflectance as follows, unless otherwise indicated:
 - 1. White Surfaces: 85 percent.
 - 2. Specular Surfaces: 83 percent.
 - 3. Diffusing Specular Surfaces: 75 percent.
 - 4. Laminated Silver Metallized Film: 90 percent.
- E. Lenses, Diffusers, Covers, and Globes: 100 percent virgin acrylic plastic or annealed crystal glass, unless otherwise indicated.
 - 1. Plastic: High resistance to yellowing and other changes due to aging, exposure to heat, and ultraviolet radiation.
 - 2. Lens Thickness: 0.125 inch (3 mm) minimum, unless greater thickness is indicated.

2.2 LED MODULES AND LED DRIVERS

- A. General:
 - 1. LED light fixtures shall be in accordance with IES, NFPA, UL, as shown on the drawings, and as specified.
 - 2. LED light fixtures shall be Reduction of Hazardous Substances (RoHS)-compliant.
 - 3. LED drivers shall include the following features unless otherwise indicated:
 - a. Minimum efficiency: 85% at full load.
 - b. Minimum Operating Ambient Temperature: -20° C. (-4° F.)
 - c. Input Voltage: 120 - 277V (±10%) at 60 Hz.
 - d. Integral short circuit, open circuit, and overload protection.
 - e. Power Factor: ≥ 0.95 .
 - f. Total Harmonic Distortion: $\leq 20\%$.
 - g. Comply with FCC 47 CFR Part 15.
 - 4. LED modules shall include the following features unless otherwise indicated:
 - a. Comply with IES LM-79 and LM-80 requirements.
 - b. Minimum CRI 80 and color temperature 3500° K unless otherwise specified in LIGHTING FIXTURE SCHEDULE.
 - c. Minimum Rated Life: 50,000 hours per IES L70.
 - d. Light output lumens as indicated in specified fixture literature.
- B. LED Fixtures:
 - 1. Housing, LED driver, and LED module shall be products of the same manufacturer.

**NISQUALLY STATE PARK
NEW FULL SERVICE PARK – PHASE 2**

2. LED drivers, modules, and reflector shall be accessible, serviceable, and replaceable from below the ceiling.

2.3 EXIT SIGNS

- A. General Requirements: Comply with UL 924 and the following:
 1. Sign Colors and Lettering Size: Comply with Authorities Having Jurisdiction.
- B. Internally Lighted Signs: As follows:
 1. Lamps for AC Operation: Light-emitting diodes, 70,000 hours minimum rated lamp life.
- C. Self-Powered Exit Signs (Battery Type): Integral automatic charger in a self-contained power pack.
 1. Battery: Sealed, maintenance-free, nickel-cadmium type with special warranty.
 2. Charger: Fully automatic, solid-state type with sealed transfer relay.
 3. Operation: Relay automatically energizes lamp from unit when circuit voltage drops to 80 percent of nominal or below. When normal voltage is restored, relay disconnects lamps, and battery is automatically recharged and floated on charger.
 4. Self-diagnostic type with test switches and indicator lights.

2.4 EMERGENCY LIGHTING UNITS

- A. General Requirements: Self-contained units. Comply with UL 924. Units include the following features:
 1. Battery: Sealed, maintenance-free, lead-acid type with minimum 10-year nominal life and special warranty.
 2. Charger: Fully automatic, solid-state type with sealed transfer relay.
 3. Operation: Relay automatically turns lamp on when supply circuit voltage drops to 80 percent of nominal voltage or below. LED module automatically disconnects from battery when voltage approaches deep-discharge level. When normal voltage is restored, relay disconnects lamps, and battery is automatically recharged and floated on charger.
 4. Integral Time-Delay Relay: Arranged to hold unit on for fixed interval after restoring power after an outage. Provides adequate time delay to permit high-intensity-discharge lamps to restrike and develop adequate output.
 5. Self-diagnostic type with test switches and indicator lights.

2.5 LIGHTING FIXTURE SUPPORT COMPONENTS

- A. Contractor shall provide “Seismic Controls for Electrical Work” such as channel- and angle-iron supports and nonmetallic channel and angle supports.
- B. Single-Stem Hangers: 1/2-inch steel tubing with swivel ball fitting and ceiling canopy. Finish same as light fixture.

**NISQUALLY STATE PARK
NEW FULL SERVICE PARK – PHASE 2**

- C. Twin-Stem Hangers: Two, 1/2-inch steel tubes with single canopy arranged to mount a single light fixture. Finish same as light fixture.
- D. Rod Hangers: 3/16-inch minimum diameter, cadmium-plated, threaded steel rod.
- E. Hook Hangers: Integrated assembly matched to light fixture and line voltage and equipped with threaded attachment, cord, and locking-type plug.
- F. Aircraft Cable Support: Use cable, anchorages, and intermediate supports recommended by light fixture manufacturer.

2.6 FINISHES

- A. Fixtures: Manufacturer's standard, unless otherwise indicated.
 - 1. Paint Finish: Applied over corrosion-resistant treatment or primer, free of defects.
 - 2. Metallic Finish: Corrosion resistant.

PART 3 - EXECUTION

3.1 INSTALLATION

- A. Fixtures: Set level, plumb, and square with ceiling and walls, and secure according to manufacturer's written instructions and approved submittal materials. Install lamps in each light fixture.
- B. Verify mounting provisions prior to the ordering of fixtures. Fixtures shall be UL listed for the location, and application in which they are installed.
- C. Install lighting fixture diffusers only after construction work, painting and clean up are completed. Prior to final acceptance, remove all, reflectors and diffusers, wash, rinse and reinstall.

3.2 SUPPORT OF LED FIXTURES

- A. Recessed Downlight Type: Mount in frames suitable for the ceiling, with the recessed portion of the light fixture securely supported from the ceiling framing. For light fixtures supported by a ceiling suspension system, provide as a minimum or as required by ARJ, two safety chains secured to structural members above suspended ceiling.
- B. Surface and Pendant Mounted Type:
 - 1. Where mounted on accessible ceilings, hang from structural members by means of hanger rods through ceiling or as approved.
 - 2. Continuous Runs of Light Fixtures: Straight when sighting from end to end, regardless of irregularities in the ceiling. Where light fixtures are so installed, omit ornamental ends between sections. For surface pendant mounted fixtures of three or more provide a unistrut channel for mounting fixtures. Provide 3/8 inch thread rod secured to structural members for support of unistrut channel.

**NISQUALLY STATE PARK
NEW FULL SERVICE PARK – PHASE 2**

3. Provide surface mounted fluorescent light fixtures with UL approval for direct mounting on the various ceilings used. Spacers will not be approved where mounted on lay-in ceilings, support light fixtures by at least two positive devices which surround the ceiling runner, and which are supported from the structure above by a No. 12 gauge wire. Spring clips or clamps that connect only to the runner are not acceptable.

3.3 CONNECTIONS

A. Ground equipment

1. Tighten electrical connectors and terminals according to manufacturer's published torque-tightening values. If manufacturer's torque values are not indicated, use those specified in UL 486A and UL 486B.

3.4 FIELD QUALITY CONTROL

- A. Inspect each installed light fixture for damage. Replace damaged light fixtures and components. Verify color temperature.
- B. Advance Notice: Give dates and times for field tests.
- C. Provide instruments to make and record test results.
- D. Test as follows:
 1. Verify proper operation, switching and phasing of each light fixture after installation.
 2. Emergency Lighting: Interrupt electrical supply to demonstrate proper operation. Verify normal transfer to battery source and retransfer to normal.
 3. Report results in writing.
- E. Malfunctioning Light Fixtures and Components: Replace or repair, then retest. Repeat procedure until units operate properly.

3.5 CLEANING AND ADJUSTING

- A. Clean light fixtures internally and externally after installation. Use methods and materials recommended by manufacturer.

3.6 FIRE-RATED ENCLOSURES

- A. The contractor shall provide 5/8" plasterboard minimum, taped box enclosures for all recessed light fixtures in 1 or 2-hour fire-rated ceilings, as required by local building or fire codes. Enclosure to provide minimum 3" air space around light fixture Contractor prior to bid shall verify Architectural drawings and specifications for areas where this provision is applicable.

3.7 CEILING TYPES

**NISQUALLY STATE PARK
NEW FULL SERVICE PARK – PHASE 2**

- A. Refer to Architecture drawings. Provide flange trim where light fixtures are installed in GWB ceilings.
- B. The Contractor prior to submitting shop drawings to the Engineer for review shall review the Architectural drawings to verify and coordinate the ceiling systems and lighting fixture frame requirements as well as proper ballast voltage. Contractor shall provide a written statement with the shop drawing submittal stating this has been completed.

3.8 CONCRETE FOUNDATIONS

- A. Install at locations shown taking care to provide soil compaction the same as required under paving to avoid settling and tilting of pole. Provide for all steel, concrete or aluminum poles shown. Concrete foundations shall have a minimum raceway sweep(s) of 90 degrees and anchor bolts shall be accurately set in foundations using a template supplied by the pole manufacturer. When concrete work has cured, base plates shall be leveled and grouted in place. Pole anchor bases shall then be set on base plates, leveled plumb on foundations, and secured with holding nuts.

END OF SECTION

**NISQUALLY STATE PARK
NEW FULL SERVICE PARK - PHASE 2**

SECTION 271000 - TELECOMMUNICATIONS CABLING

PART 1 - GENERAL

1.1 WORK INCLUDED

- A. Bidding documents including Division 00 General Conditions, Published Addenda and related work in other Divisions form an integral part of these Specifications and shall be binding on the Division 26 Contractor for all work performed under Division 26, Electrical.

1.2 DESCRIPTION

A. Definition

- 1. "Telecommunications Cabling" as used in this Section refer to a unified cable plant primarily designed for carrying signals associated with telephone, telecommunications common carrier, data, and communications within the building or between buildings. At places, interfaces occur between the telecommunications cabling system and other signal cable systems, and telecommunications systems may share tray and rack spaces with other systems. However, for construction purposes the "Telecommunications Cabling" system is separate and may have different specification provisions from other systems.

B. Station Cable

- 1. Provide a complete cable system tested for continuity and performance to each outlet, including:
 - a. Category 6 station cables for voice/data interconnections
 - b. Multi-Mode and single mode fiber connections for multi use applications
 - c. Multi-purpose outlet plates
 - d. RJ-45 jacks and terminations
 - e. Rack mounted RJ-45 patch panels
 - f. Rack mounted fiber patch panels
 - g. Equipment Racks
 - h. 110 blocks and terminations

- C. Copper Backbone Cable: Provide a backbone cable system tested for continuity and performance, consisting of category 3 UTP telephone riser cable.

- D. Fiber Optic Backbone Cable: Provide a complete tested, and documented backbone data cabling system consisting of multimode and single mode fiber outside plant optic cable, including termination shelves, connector termination and testing.

- E. Telecommunications Rooms: Provide telecommunications room equipment racks, overhead ladder rack, wire management, and terminating hardware as specified.

**NISQUALLY STATE PARK
NEW FULL SERVICE PARK - PHASE 2**

- F. Identification and Labeling: Labeling is to be functional and permanent, in strict compliance with Owner/Engineer direction.
- G. Detailed Documentation:
 - 1. Provide detailed documentation of as-built conditions required for this section to complete shop drawings for telephone and data cabling system administration. Labeled cables connected at each outlet location must be those shown in “as-built” documentation.
- H. Work Furnished By Others:
 - 1. Telephone switching equipment, telephone instruments, computing equipment, and data switches will be furnished by others.
 - 2. ANY connections to active equipment in a telecommunications room will be performed by Owner IT staff only.

1.3 PRE-CONSTRUCTION CONFERENCE

- A. Early in the construction time line, and before any shop drawings are provided, a representative of the low voltage communications installer, who shall serve as supervisor to the installation crew throughout construction, shall attend a pre-construction meeting with General Contractor, Electrical Contractor, owner, Architect and Electrical Engineer where installation details, including labeling and wire management will be discussed.

1.4 SYSTEM DESIGN OBJECTIVES

All recommended revision, Value Engineering suggestions, or installer options during the construction phase should consider the following design objectives:

- A. System Description: The cabling system is designed to support a universal cabling system for both voice and data. Most information outlets will consist of outlet boxes with uniform Category 6 jacks for voice and data. The size of outlet boxes and conduit at each location are indicated on the electrical drawings and in the electrical specifications.
- B. Telecommunication Room Support Fixtures:
 - 1. The telecommunications room(s) shall be equipped with equipment racks, ladder rack, patch panels, termination panels, power outlets, power strips, and other furnishings required to facilitate an installation that is neat, functional, flexible, and earthquake resistant to local code.
 - 2. All telecommunications room fixtures must be installed as shown in the drawings, or alternate plans must be expressed in approved shop drawings before materials are ordered or work begins. The contractor shall be responsible for any work or re-work required due to improper approval and/or acceptance of work performed which differs from the construction documents at no cost to the Owner.

**NISQUALLY STATE PARK
NEW FULL SERVICE PARK - PHASE 2**

1.5 REGULATORY REQUIREMENTS

- A. All work shall be performed in accordance with the latest revisions of the Washington Department of Labor and Industries and the following industry standards and codes:

FCC Part 68	Connection of terminal Equipment to Telephone Network.
Uniform Building Code	International Conference of Building Officials (ICBO; Regional Office: 12605 Bellevue-Redmond Road, Bellevue, WA 98005
WAC-296-46	Laws, Rules, and Regulations for installing Electric Wires & Equipment
NFPA 70 (NEC)	1999 National Electrical Code
NFPA 75	Protection of Electronic Computer and Data Processing Equipment
NFPA 78	Lightning Protection Code
NFPA 101	Life Safety Code
OSHA 29 CFR Part 1910	Occupational Safety and Health Standards
FCC Part 76.611	CFR Title 47 Radiation Leakage Standards

- B. Other References:

ANSI/TIA/EIA-526-14A	Optical Power Loss Measurements of Installed Multimode Fiber Cable Plant
ANSI/TIA/EIA-569-A	Commercial Building Standard for Telecommunication Pathways and Spaces
ANSI/TIA/EIA-568-B	Commercial Building Telecommunications Cabling Standard (Includes B.1, B.2 & B.3 including addenda)
ANSI/TIA/EIA-606-A	The Administration Standard for the Telecommunication Infrastructure of Commercial Buildings
ANSI/TIA/EIA-607	Commercial Building Grounding and Bonding Requirements for Telecommunications
ANSI/TIA/EIA-758-A	Customer-Owned Outside Plant Telecommunications Standard

- C. Governing codes and Conflicts: If the requirements of this section of the project drawings exceed those of the governing codes and regulations, then the requirements of this section and the Drawings shall govern. However, nothing in this section or the drawings shall be construed to permit work not conforming to all governing codes and regulations.

**NISQUALLY STATE PARK
NEW FULL SERVICE PARK - PHASE 2**

1.6 COORDINATION

- A. The necessity to coordinate this work with the Serving Utility (Rainier Connect), Owner (Washington State Parks) and the other on site Contractors is emphasized. The Contractor shall be responsible for any omissions, delays and additional cost due to lack of coordination or approval from the same.
- B. Coordinate work with other contractors and trades. The layout and installation of the systems shown on the drawings and specified herein shall be coordinated such that all special requirements for the telecommunications systems shall be provided and incorporated into the project. The systems to be coordinated shall include (but are not limited to) electrical raceway, grounding, fire rated assembly, lighting, power distribution, control and labeling of cables, termination, outlets, jacks, etc. Report all conflicts to the Architect/Engineer.

1.7 INSTALLER QUALIFICATIONS AND QUALITY ASSURANCE

- A. The Low Voltage cable system installer shall at a minimum be firm normally employed in the low voltage cabling industry with reference list of at least (5) five projects with contact names to confirm the successful completion of Category 6 UTP and fiber optic cable plant projects within the last (12) twelve months prior to the bid opening date of this project. In addition, the Contractor must submit proof of category 6 UTP and fiber optic cable test equipment training and certification for the technicians that will be testing the installation. The Contractor shall discuss Category 6 testing procedures with the Owner and Engineer prior to beginning testing.
- B. Documentation demonstrating that the Contractor employs a minimum of one registered communications distribution designer (RCDD) certified by and in current good standing with BICSI. The RCDD shall be a direct full time employee of the Contractor (i.e. an RCDD consultant/sub-contractor to the contractor is not acceptable. The document shall also declare that the Contractor will continue to employ a minimum of one RCDD throughout the duration of project.
 - 1. During the course of construction, the Contractor's RCDD shall periodically (once per two-week period) review (on-site) the construction in progress for conformance to ANSI/TIA/EIA and BICSI installation standards. The written report to the Owner/Engineer on company letterhead, which details the work, reviewed and states the work conforms to ANSI/TIA/EIA and BICSI installation standards.
 - 2. After substantial completion and prior to Owner acceptance, the contractor's RCDD shall certify in writing on company letterhead the completed installation meets or exceeds ANSI/TIA/EIA and BICSI installation standards. The written certification shall be complete with RCDD's stamp and certification number and shall bear the RCDD's signature across the face of the stamp.
- C. The Owner/Architect/Engineer reserves the right to exercise it's discretion to require the Contractor to remove from the project any such employee of the Contractor deemed by the Owner to be incompetent, careless, or insubordinate.

**NISQUALLY STATE PARK
NEW FULL SERVICE PARK - PHASE 2**

- D. Personnel whom the Contractor intends to use as supervisors or testers, and at least (50%) half of the installation technicians at large, must have been employed by the Contractor for at least (6) six months as of the date of the bid opening. Proof of AMP and AMP/Mohawk certification for each technician is required showing they have been trained and are familiar with the products they will be installing. Technicians shall have been trained on the Contractor's company policies with respect to personnel safety, telecommunications industry cabling quality and neatness standards, and use of CSI-standard specifications and drawings.
- E. A (25) twenty-five year AMP or Mohawk performance and installation warranty shall be provided by the selected Low Voltage installer. The contractor must be certified by AMP and Mohawk if Mohawk cable is used at the time of bid. This warranty shall include defects in workmanship and/or material. The warranty period shall begin at the date of the Owner's acceptance of the work. Quality and workmanship evaluation shall be made solely by the Engineer.
- F. The selected Low voltage installer must be licensed, bonded, and insured in the State of Washington.

1.8 UNIT PRICES

- A. In the Schedule of Values unit prices must be submitted for addition or deletion of telecommunications wiring devices during the period of this contract. The pricing shall include all costs associated for addition and the credit for deletion of outlets and locations. In addition, unit pricing shall be submitted for addition or deletion of patch panels, wire managers, racks, cable, etc.

1.9 SUBMITTALS

- A. The Contractor shall finish the following in a single consolidated submittal with an approval copy to the Owner:
 - 1. Contractor's license number and proof of qualifications required in paragraph 1.6 above.
 - 2. Contractor's certification certificate from AMP.
 - 3. The name of the person who will act as the Contractor's official contact with the Contractor/Owner/Engineer.
 - 4. The name of every certified Category 6 and fiber optic cable installation technician who may be used in the conduct of the project, and evidence of certification of each.
 - 5. To qualify, under the preceding paragraph, courses attended must include hands-on access to cable and terminating tools and materials, and test equipment required to perform the installation functions required in the work of this contract.
 - 6. Complete manufacturer's product literature for all products to be used in the installation except for the Owner furnished materials. In addition, whenever Owner/Engineer pre-approved substitutions are recommended products are made, samples (when requested by the Owner/Engineer) and the manufacturer's supporting documentation demonstrating compatibility with related products shall be included. Product submittals must be keyed to the specification or drawing references.

**NISQUALLY STATE PARK
NEW FULL SERVICE PARK - PHASE 2**

7. Shop Drawings.
 - a. Proposed cable routing shall be submitted and approved prior to installation of any cables.
 - b. The contractor shall submit scaled drawings of all proposed changes in communications room installation detail.
 8. Proposed Contractor category 6 UTP and fiber optic cable test result forms. Backbone UTP cables shall be tested as provided herein. Contractor shall provide test documentation and forms.
 9. Examples of the cable labeling materials and proposed arrangement. Submittal must include actual samples of each type of proposed connecting fixture, with realistic labels attached.
- B. A time-scaled Construction Schedule indicating general project deadlines and specific dates relating to the installation of the cable distribution systems described for this project. At a minimum, this Construction schedule shall include the following milestones:
1. start and completion of Comm room installation
 2. start and completion of backbone cable installation
 3. phasing of station cable installation
 4. testing dates
 5. cable label documentation delivery
 6. final inspection
- C. Project Completion

As a condition for project acceptance, the contractor shall submit to the Owner/Engineer the following for review and approval:

1. Complete manufacturer's product literature and samples (if requested) for all approved substitutions to the recommended products made during the course of the project.
2. An Exceptions List of deviations (in materials, construction, and workmanship) from the specified in this section and shown on the Project Drawings. The Owner will review this list and declare each item as either an approved exception, or as one the Contractor must correct.
3. Filed Drawings. Through out the course of the project, details concerning the exact physical layout or arrangement of the backboards as shown on the Construction Drawings and details shall be marked on the field set 9with dimensions and inches) reserved for this purpose. The field drawings shall be available through out the project for inspection and shall be submitted to the Consultant/Engineer at Project Completion with changes "as-builts" in CADD format and submitted on CD. The Field Drawings shall be clear and accurate so the original Construction drawings can be brought up-to-date by the Contractor.
4. Inspection and test Reports: During the course of the Project the Contractor shall maintain the adequate inspection system and shall perform such inspections to insure that the materials supplied and the work performed conform to Contract requirements. The Contractor shall provide written documentation, which indicates that all cable termination testing was completed and all irregularities were corrected prior to job completion.

**NISQUALLY STATE PARK
NEW FULL SERVICE PARK - PHASE 2**

1.10 PROJECT OBSERVATION AND FINAL ACCEPTANCE

- A. The Contractor shall request interim observations by the Owner/Engineer throughout the course of the project to avoiding costly corrections at the end of the project.
- B. The Contractor shall incorporate in the construction schedule a minimum 2-week period for the final review and project observation process. During this period, the Owner/Engineer will review the project completion submittals and conduct on-site observation.
- C. The Field Drawings will be checked for completion and accuracy to be compared to engineer provided construction documented and details from the start of the project.
- D. The Owner/Engineer will generate a list of materials and workmanship that are not acceptable (in a project observation report/punchlist). Any part of the system, materials or workmanship, not meeting the requirements of this section, and not otherwise accepted by the Owner/Engineers, shall be corrected by the Contractor at no additional cost to the Owner prior to final acceptance.
- E. A follow-up observation shall be made after the Contractor has made all corrections necessitated by earlier project observation reports. This review and observation process will be repeated as required until final acceptance is granted.
- F. If completed test results for copper and fiber cables are questionable in regard to failures, an independent spot test on cables with problems may be done by a different independent contractor, with the cost of such spot-checks to be retained from Contractor's payments.

1.11 CABLE LABELING AND PLACEMENT

- A. Cable terminations shall be labeled according to Owner/Engineer instructions onsite.
- B. Cables will be assigned specific termination locations. Such assignment may be made or changed by the Owner/Engineer at any time prior to the installation phase at no additional cost to the owner or contract.

PART 2 - PRODUCTS

2.1 GENERAL

- A. All material required for a complete installation shall be furnished by the Contractor.
- B. All materials must be new, free from defects and not less than the quality herein specified. They shall be designed to insure satisfactory operation and operation life in the environmental conditions which will prevail where they are being installed.

**NISQUALLY STATE PARK
NEW FULL SERVICE PARK - PHASE 2**

- C. Each type of materials bid and furnished shall be of the same make and shall be of the standard products or manufacturers regularly engaged in the production of such materials and shall be the manufacturer's latest standard design.
- D. Materials shall be as listed or shall be equivalent products of other manufacturers meeting the intent and quality level of the specifications. Any approved equivalent products will be published by addendum prior to bid.
- E. Security: Contractor shall furnish and maintain suitable lockable storage locations for on-site secure storage of materials. Any lost, stolen, damaged, or cut materials shall be replaced by the Contractor.
- F. No custom items shall be used except as specified on the Construction Drawings or as reviewed and approved by both the Owner and Engineer as required to meet unusual physical requirements *of* the installation site.

2.2 WIRE PLANT MATERIALS

- A. Materials shall be as listed or shall be equivalent products *of* other manufacturers meeting the intent and quality level *of* the EIA/fIA-568-B specifications. All approved equivalent products will be published by addendum prior to bid.
- B. All products shall be new and brought to the job site in original manufacturer's packaging. Electrical components (including innerduct) shall bear the Underwriter's Laboratories label and/or the CSA equivalent. All communications cable shall bear flammability testing ratings as follows:

CM Communications Cable
CMP Plenum Rated Communications Cable
CMR Riser-rated Communications Cable
All voice and data station cables specified herein shall be CMP plenum as required by code.
- C. Initial Cable inspection: The Contractor shall inspect all cable prior to installation to verify that it is identified properly on the reel identification label, that it is *of* proper gauge, containing correct number of pairs, etc. Note any buckling *of* the jacket which would indicate possible problems. Damaged cable or any other components failing to meet specifications shall not be used in the installation.

2.3 SUBSTITUTION OF MATERIALS

- A. Listing of materials is not intended to prevent listing *of* other material.
 - 1. No requests for variance prior to bid will be approved unless it is stated a pre-approved product may be submitted for review and listing.
 - 2. After Award of Contract, only as follows:
The reason for the unavailability is beyond the Contractor's control, i.e., due to strikes, bankruptcy, discontinuance of manufacture, etc. Requests for substitutions shall be made in writing and shall be accompanied by complete description *of* the substitute material or equipment.

**NISQUALLY STATE PARK
NEW FULL SERVICE PARK - PHASE 2**

- B. In all cases, should a substituted material result in requiring system or building modifications, or additional labor on the part of the installation contractor(s), the Contractor shall be liable for all costs to provide these modifications including all costs to the Engineer for redesign time required to accommodate the required modifications. Liquidated damages provisions of the Contract may also apply.

2.4 BACKBONE CABLES

- A. Telephone Multi-conductor Riser Cables: The multi-conductor telephone cables shall be 24 AWG with electrical specifications as follows:

1. Typical Parameters:

- a. EWTIA Specification Category 3
- b. Mutual Capacitance: 20 pF/ft, 66 pF/m
- c. Char. Impedance: 100 +/- 20
- d. Attenuation:
 - 1) 7.7 dB/1000 ft, 2.5 dB/100m @ 1 MHz
 - 2) 18 dB/1000 ft, 5.9 dB/100m @ 4 MHz
 - 3) 30 dB/1000 ft, 9.8 dB/100m @ 10 MHz
 - 4) 38 dB/1000 ft, 12 dB/100m @ 16 MHz

Acceptable Products: (See Below)

Campus Connection: Essex 300 pair PE-39, or pre-approved equal

Voice Extensions: Mohawk# M56126 (50 pair Cat 3)

- B. Optical Fiber Cable:

1. Outside Plant

- a. 50/125 urn -12 strand Multi-Mode and 48 strand Single Mode optical fiber cables for backbone.
Single Mode Acceptable Products:
AMP# 048SCSILAFERJA Mohawk #M93814
Multi-mode Acceptable Products:
AMP# 012MBSILABNRJB Mohawk #M9 A811

2. Inside Plant

- a. 50/125 urn -12 strand Multi-Mode and 12 strand Single Mode optical fiber cable for backbone.
Single Mode Acceptable Products:
AMP# 012SEHNTATJPNY Mohawk #M93048

Multi-mode Acceptable Products:
AMP# 012MBHNTATJPNN Mohawk #M9A048
Contractor shall supply required length for planned route plus 25 foot maintenance service loops at each end.

**NISQUALLY STATE PARK
NEW FULL SERVICE PARK - PHASE 2**

2.5 STATION CABLING

- A. Voice/Data Station Cable: Provide Category 6 cable (as identified by TIA/EIA-568-B) for all voice/data station cables: Each cable reel shall be tested for Category 6 performance at the factory. All cable shall be plenum rated.

Acceptable Products:

AMP# 219667-X (White for Campus Network) 219567-X (Violet for CIT)

Mohawk# M56905 (White for Campus Network) M57201 (Violet for CIT)

NOTE: Floor box locations to have 10' of cable coiled under floor so that floor box locations have the ability to be relocated within a 10' radius.

2.6 STATION HARDWARE

- A. Jacks: Flush mount voice and data jacks shall be high quality tested Category 6 8-pin (RJ45) modular jacks with IDC style terminations. All jacks shall use the T568B pin configuration. Jacks shall exceed the TIA/EIA-568-B recommendations for Category 6 connecting hardware. Confirm campus network wall and floor box outlet colors with Owner/engineer.

Acceptable Products: (See Below)

Wall and Floor Box Locations:

AMP # 1375055-X

AMP# 1-1375055-0 (Violet for CIT)

- B. Icons and Labels: Icons shall have voice or data symbols as appropriate

Acceptable Products: AMP icons

- C. Faceplates: Faceplate color shall be determined by the Owner/Engineer.

Acceptable Products:

AMP Faceplate# 1139118-X

AMP Module# 1116409-X AMP Blank# 1116410-X

Floor Box Faceplate: Spider Mfg AMP Faceplates

- D. Consolidation Points/MUTOAS: Consolidation points are to be installed under the floor with transition cables routed to furniture and installed in standard faceplates

Acceptable Product:

AMP # 406771-1

Cat 6 6-Pack Inserts: 1375367-1

Transition Cables: 219599-1

- E. Cable labels.

1. All cables shall be labeled at the TR termination and at the user terminal connection with the same identifying code.
2. TR-end labels shall be mechanically printed on strips designed for use with the prescribed terminating hardware.
3. Jack-end labels must be mechanically created, have letters that are at least 3/16 inches high, and have a high contrast with the label background.

**NISQUALLY STATE PARK
NEW FULL SERVICE PARK - PHASE 2**

4. Label adhesive must be shown to be permanent and not removable without use of heat or solvents, when applied to each of the types of outlet cover plates to be used in the project.

2.7 VOICE/DATA TERMINATION HARDWARE

- A. Backbone Voice Hardware.

Acceptable 110 Products (for walls):

AMP 300 pair blocks without legs

Mounting Frame: Homaco Part# 110D-1800W

Acceptable Voice patch Panels

AMP 48-Port Cat 6 #1375015-1

Category 3 50-pair cable will terminate from voice patch panels to wall mounted 110 blocks. One pair to each port on the patch panels - pins 4 and 5. Cross-connects will be preformed at the 110 wall field by the *Owner* IT Staff.

- B. Termination clips: Equip termination frames with C4 and C5 type clips for riser cabling.
- C. Termination Block Label Strips: Standard colored designation label strips that match the colors indicated for voice and data icons shall be affixed to each row of the 110-type wiring termination. For PBX-feed cables, labels shall be white.
- D. Horizontal Voice/Data Cabling Patch Panels. 1. 48 port Category 6 patch panel.
Acceptable products: AMP Part# 1375015-1
- E. Horizontal Wire Managers. There shall be horizontal wire managers between each patch panel as shown in drawings.

Acceptable product: AMP Part# 1375159-1
- F. Equipment Racks. Provide 7'x19" racks per Telecommunications Room details. Equipment racks must be base mounted, grounded with a #6 ground wire and secured to structure and overhead tray.

Acceptable product: Ortronics part# OR-60400169 with OR-60400433 wire mangers between racks and at the end of the rows

4-PostRacks: SWDP: SWE310BLK

2.8 FILLER OPTIC CABLE TERMINATIONS

- A. The contractor is to provide complete enclosures. The enclosures used in the Communications Rooms for the optical fiber risers shall be of sufficient size and capacity to terminate all of the combined fiber count of the vertical riser fiber optic cables. The contractor shall provide complete fiber optic patch panels and all required materials, i.e. coupler panels, blank panels and connectors, as shown on plans for multi- mode fiber termination panels with SC connectors for single mode and MTRJ connectors for multi-mode.

Acceptable Products: (See Below)

Campus Fiber Enclosure: AMP# 559552-2

MDF/Server Room Enclosures: AMP# 559542-2

**NISQUALLY STATE PARK
NEW FULL SERVICE PARK - PHASE 2**

Single Mode Adapter Plate: AMP# 559558-2
Multi-mode Adapter Plate: AMP# 1278328-3
Blank Plates: AMP# 559523-1
Single Mode Connectors: AMP# 504655-4 (SC)
Multi-mode Connectors: AMP# 1588880-1 (MTRJ)

2.9 MDF/SERVER ROOM CABLE TRAY

- A. Size: 12 inch wide x 4 inch deep as shown on the drawings with all necessary support hardware and seismic bracing. Provide all accessories required for a complete installation as required.
- B. Cable tray shall be continuous, rigid, welded steel wire mesh cable management system. Material shall be stainless steel wire, AISI 316L, 2B, finished cold drawn wire.
- C. Cable tray sections shall be mechanically and electrically continuous at all splices, changes in elevation, etc. Connections between sections shall attach using hardware and accessories of the same manufacture as the cable tray and shall be installed per manufacturer's recommendations. Connections shall be listed by a Nationally Recognized Testing Laboratory as electrically continuous for purposes of grounding continuity, or supplemental bonding jumpers shall be provided at connections.
- D. Support system shall be Cablofil FAS system. Provide brackets as required for ceiling or wall installation as indicated on drawings. Install per manufacturer's recommendations.
- E. Provide Cablofil FAS Rollers for cable pulling at all angles, bends, and level changes in the tray.
- F. Compression-type, copper alloy connector lugs shall be provided for bonding and grounding conductor connections to cable tray. Grounding and bonding connection hardware shall be of the same manufacture as the cable tray.
- G. Provide manufacturer's cable drop out accessory where cables exit tray. Part #DROPOUT.
- H. Acceptable Product: Cablofil EZ Tray, part # CF 105/300 EZ or pre-approved equal

2.10 BUILDING ENTRANCE TERMINALS AND PROTECTORS

- A. Building entrance terminals with connector blocks consisting of flame-retardant molded plastic fastened to a metal mounting bar shall be provided to terminate the outside plant cable as shown. The connector blocks shall be of 100-pair block size and equipped with protection modules as shown on drawings. The connector blocks shall be 110 in and 110 out. All terminals are to be provided with a ground lug and grounded.
Acceptable Product: Circa# 1880ECAI-I00G
- B. The protector modules shall be 5 pin solid state type modules with PTC's to protect against "sneak currents." Acceptable Product: Circa# C4BIS (PTC).

**NISQUALLY STATE PARK
NEW FULL SERVICE PARK - PHASE 2**

2.11 SEISMIC BRACING

- A. Ladder racks and free-standing equipment racks shall be seismically braced in accordance with requirements for seismic Zone 4. Seismic bracing shall consist of rigid supports. Cables, wires, chains or other non-rigid materials shall not be used for seismic support. Provide approved fixed equipment anchorage assemblies as published by the manufacturer. In lieu of manufacturer's published seismic bracing assemblies, the Contractor shall provide seismic installations approved by a licensed structural engineer.
- B. Approved drawings of seismic assemblies shall be made available for review by the Contracting Agency or the inspecting Authority Having Jurisdiction upon request.

2.12 MDF/SERVERROOMS

- A. Termination Backboards
 - 1. Material: Type CDX plywood. Label fire treated. Do not paint.
 - 2. Size: 3/4 inch thick x 8 feet high to cover walls as shown on drawings.
 - 3. Finish: White flat latex paint. Paint plywood on all sides and edges prior to mounting on walls.
- B. Grounding
 - 1. Per ANSI/TIA/EIA 607 - Commercial Building Grounding and Bonding Requirements for Telecommunications, and National Electrical Code, provide and install in MDF and Server Room copper ground bars which are connected to building ground system via minimum #6 A WG green insulated copper grounding conductor.
 - 2. Copper ground bars shall be CPI #10622

PART 3 - EXECUTION

3.1 FIRE STOPPING

- A. Any penetration through fire rated walls, and both ends of all vertical conduit chases (including those in sleeves) will be sealed with specified fire stopping sealant.
- B. Contractor shall also seal all floor, ceiling, and wall penetrations in fire or smoke barriers and in the telecommunications rooms.

3.2 CABLE HANDLING

- A. All cable, especially Category 6, is subject to subtle damage that may degrade future performance, if abused during installation. In all cable installation, set reels and use sufficient pulleys and manpower so that cables are not pulled around blunt corners or against material that might cause chafing. For the purpose of this paragraph, any edge with a radius of less than 5 inches is considered "blunt". Any non-rotational surface that has sufficient friction to cause shavings or particles to be pulled off of cable jackets is unacceptable.

**NISQUALLY STATE PARK
NEW FULL SERVICE PARK - PHASE 2**

OBSERVATION OF IMPROPER CABLING HANDLING TECHNIQUES ON THE JOB MAY CAUSE THE CONSULTANT/ENGINEER AND/OR OWNER TO REQUIRE THE CONTRACTOR TO DISCARD OBSERVED CABLES, INCLUDING ANY OTHERS ALREADY INSTALLED BY THE PERSONNEL FOUND USING IMPROPER TECHNIQUES.

- B. Allowable Cable Bend Radius and Pull Tension: In general, communications cable cannot tolerate sharp bends or excessive pull tension during installation. The following tables provide typical minimum pulling bend radii and maximum pull tensions for twisted-pair and fiber optic cables in conduit.

Refer to manufacturer's recommendations for the limitations on the installed cables.

**MINIMUM PULLING BEND RADIUS and MAXIMUM PULL TENSION FOR
TWISTED-PAIR CABLE in CONDUIT**

PAIRS	MINIMUM PULLING BEND RADIUS	MAXIMUM PULL TENSION
4	5 inches	25 lbs.
100	17 inches	500 lbs.
200	22 inches	1000 lbs.
900	44 inches	5000 lbs.

**MINIMUM PULLING BEND RADIUS and MAXIMUM PULL TENSION
FOR OPTICAL FIBER CABLE in CONDUIT**

PAIRS	MINIMUM PULLING BEND RADIUS	MAXIMUM PULL TENSION
Riser	5 inches	275 lbs.

Cable Lubricants: Lubricants specifically designed for installing communications cable may be used to reduce pulling tension as necessary when pulling cable into conduit. After installation, exposed cable and other surfaces must be cleaned free of lubricant residue.

Recommended Products:

Twisted-pair Cable: Dyna-Blue, American Polywater Optical Fiber Cable: Optic-Lube, Ideal

- C. Pull Cords: Provide pull cords in all sections of conduit. Tapes shall be marked in feet and secured at each end of the conduit.

Recommended Product: Greenlee

- D. Replace or rework cables showing evidence of improper handling including stretches, kinks, short radius bends, over tightened bindings, loosely twisted and over twisted pairs at terminals,

**NISQUALLY STATE PARK
NEW FULL SERVICE PARK - PHASE 2**

and re-terminate cables with sheath removed over 2 inches

3.3 FIBER OPTIC BACKBONE CABLE INSTALLATION

- A. Install multimode optical fiber in innerduct between telecommunications rooms as shown on prints. Provide 10-foot service loops at both ends coiled neatly above, but not on, the rack.
- B. Terminations shall be performed by a manufacturer certified technician for SC and MTRJ connections.
- C. Terminations shall be made in a controlled environment. The Contractor may choose to have the cable assembled off-site, although testing must be completed with the cable in its final installed condition.

3.4 LABELS

- A. The Contractor will label all outlets and cables using permanent, legible typed or machine engraved labels pre-approved by the Owner. Submit proposed labels to Engineer/Consultant for approval.
- B. Terminals in the telecommunications rooms shall be labeled by the Contractor using designation strips designed for the patch panels or terminal hardware.

3.5 STATION CABLING INSTALLATION

- A. Certified Installers: The Contractor shall supervise the installation of all communications cable. All Category 6 cable shall be installed by individuals trained and certified in low voltage data cable system installation. All Category 6 cable must be handled with care during installation so as not to change performance specifications. The Contractor shall not over tighten wraps or over bend cables.
- B. Station cables shall be typically installed in under floor spaces. Any cable placed in ceiling areas shall be supported with Erico J-hooks attached appropriately to walls or support wires and spaced a maximum of four feet apart. Cables shall not come in contact with HV AC or mechanical system components or run within (8) eight inches of any electrical component. Provide straight routes, parallel with floors and corridor walls, between the outlet box locations and the telecommunications room.
- C. Coordination: All cabling and associated hardware shall be placed so as to make efficient use of available space in coordination with other uses. All cable and associated hardware shall be placed so as to not impair the use or capacity of other building systems, equipment or hardware placed by others (or existing). All cable, associated support structures and hardware shall be placed so as to not impair the Owner's efficient use of their full capacity.
- D. Installation: Pull all cables carefully, adhering to standards of care and manufacturer's recommendations for installation of cabling. Where cables emerge from raceways or drop out of cable racks, maintain a supported bundle with at least a (5) five-inch bend radius. Use special care not to pull cables around comers unless a large-radius pulley or careful manual handling is employed. Assure that when cables are left on the floor, signs or other procedures are used to

**NISQUALLY STATE PARK
NEW FULL SERVICE PARK - PHASE 2**

assure that no one steps on the cables. (In the event an observing Owner's representative, Consultant/Engineer, or Architect observes installation practices in which cables are subject to crushing or tight-bend abuse, the Contractor may be required to remove and discard from the site all cables which may have been subjected to the observed abusive action. No additional charges will be allowed in the event of such replacement action.)

NOTE: Cabling installation shall not precede floor installation

3.6 TELECOMMUNICATION ROOM DETAILS

- A. Mount termination equipment per drawing details. Leave clear routes for riser and station cable bundles as indicated.
- B. Support ladder racks on walls using manufacturer supplied triangular support brackets and wall angles. Attach ladder rack to equipment rack where ladder rack passes over equipment rack. Support free spans greater than (6) six feet using a trapeze style support consisting of (2) two sections of all-thread and a section of C-channel supporting the ladder rack.
- C. Mount power strips on the back side of the vertical wire management using manufacturer supplied offset brackets.
- D. Install 110 termination blocks for copper backbone cable.
- E. Install fiber optic termination shelf for fiber optic backbone cable.
- F. Coordinate with other work of Division 26 to assure installation of power outlets, sleeves, ground bus bar, and backboard in each location shown on the drawings. Keep telecommunications cabling clear of spaces designed for power outlets. Telecommunications cable jackets shall not come in contact with electrical outlet boxes or conduit at any point in the system.

3.7 STATION HARDWARE

- A. UTP cables shall be terminated in high-quality Category 6 RJ-45 jacks meeting EIA/TIA-568-B specifications, using wiring format T568B (TIA), which is both 100baseT and ISDN compatible.

3.8 BACKBOARD CABLING/EQUIPMENT RACK CONFIGURATION

- A. Cabling shall be routed to avoid interference with any other service or system, operation, or maintenance purposes such as access boxes, ventilation mixing boxes, network equipment, mounting access hatches to air filters, switches or electrical outlets, electrical panels, and lighting fixtures. Avoid crossing areas horizontally just above or below any conduit opening. Lay and dress cables to allow other cables to enter the conduit/riser without difficulty at a later time by maintaining a working distance from these openings.
- B. Cable shall be routed as close as possible and parallel to the ceiling, floor, or corners to insure that adequate wall or backboard space is available for current and future equipment and for

**NISQUALLY STATE PARK
NEW FULL SERVICE PARK - PHASE 2**

cable terminations. Cables shall not come in contact with, electrical conduit or other equipment.

- C. Cable bundles passing from a wall to a rack or other free-standing object shall not bridge a gap of greater than (4) four inches without the use of a uni-strut or other bridging structural piece. All cables to a rack shall be cabled out to the top. On backboards, lay cables via the shortest route directly to the nearest edge of the backboard from the mounted equipment or block.
- D. Lace or bundle all similarly routed cables together, and attach by means of D-rings screwed to the outside edge(s) of the backboard vertically and/or horizontally, then route via "square" comers over a path that will offer minimum obstruction to future installations of equipment, backboards, or other cables.
- E. Do not allow binding on cable. Do not use tie-wraps. Velcro-style straps are recommended for cable bundling, where required. Observe Category 6 cable bend radius standards for all cables.

3.9 COPPER CABLE INSTALLATION TESTING

- A. The Owner/Engineer shall be notified one week prior to any testing so that the initial testing may be witnessed. Contractor shall not replace or correct any cable deficiencies found through testing prior to the notified date. (The initial test results are an effective indication of the overall quality of an installation. "Rehearsal" tests by the Contractor deprive the test observer of the opportunity to detect general quality conditions that may be detected at the time of the first test performed.)
- B. Before requesting a final inspection, the Contractor shall perform a series of end-to-end installation performance tests. The Contractor shall submit for approval a proposal describing the test procedures, test result forms, and timetable for all copper plant wiring.
- C. Acceptance of the simple test procedures discussed below is predicated on the Contractor's use of the recommended products (including but not limited to twisted-pair cable, cross-connect blocks, and outlet devices specified in the Products paragraph), and adherence to the inspection requirements and practices set forth. Acceptance of the completed installation will be evaluated in the context of each of these factors.
- D. At a minimum, the Contractor shall test:
 - 1. All copper backbone cable pairs for continuity from source to destination.
 - 2. All station drop cable pairs from telecommunications rooms to outlet device RJ45 jacks.
- E. Each Category 6 wire/pair shall be tested per TWEIA-568-B, including addenda, at a minimum for the following:
 - 1. Wire map
 - 2. Length
 - 3. Insertion loss
 - 4. Near-end crosstalk (NEXT) loss
 - 5. Power sum near-end crosstalk (PSNEXT) loss
 - 6. Equal-level far-end crosstalk (ELFEXT)
 - 7. Power sum equal-level far-end crosstalk (pSELFEXT)
 - 8. Return loss

**NISQUALLY STATE PARK
NEW FULL SERVICE PARK - PHASE 2**

9. Propagation delay 10. Delay skew
- F. These test procedures shall be based on EIA/TIA-568-B utilizing a commercial Level III UTP cable tester that will test at or above the Category 6 parameters. Acceptable test equipment includes Fluke DSP-4XXX, Aglient Scope 350 or other approved tester. Testers shall have the latest software update. Testers shall be set for Category 6 cable tests. Each tester shall be certified as calibrated within (3) three months of testing.
- G. UTP Category 6 cables shall be tested from the telecommunications room to RJ45 outlets in small groups. After a small group of station cables are installed, they must be tested. Test groups shall consist of no more than (40) forty cables.
- H. The Category 6 testing will show numerous problems which go undetected with lower frequency testing including the following:
1. Stretched cables.
 2. Kinked cables.
 3. Short bend radius.
 4. Tight bindings.
 5. Loose twists and tight twists at terminals.
 6. Cable sheath removed too far.
- I. When errors are found, the source of each error shall be determined, corrected, and the cable re-tested. All defective components shall be replaced and retested. Defective components not corrected shall be reported to the Owner/Engineer with explanations of the corrective actions attempted.
- J. Test records shall be maintained using the test equipment manufacturer's electronic form. The form shall record cable identification number, outcome of test, indication of errors found, cable length, re-test results after problem resolution, and signature of the technician completing the tests. Test results shall be submitted in electronic spreadsheet format (Excel or Word compatible) on disk with a printed copy. Test results for each test group shall be submitted within two days of tests for immediate review.
- 3.10 FIBER OPTIC Cable INSTALLATION TESTING
- A. All testing shall be performed by trained, certified personnel.
- B. A calibrated OTDR is required to test all the bare fiber optic cables on the reels prior to installation. This includes testing on the 850 nm and 1300 nm range for multi-mode and 1310 nm and 1550 nm range for single mode fiber optic cable. Recorded printouts are to be submitted.
- C. Installed fiber must be tested in accordance with TIA/EIA-568-B, including addenda and ANSI/TIA/EIA-526-14A, Method Band ANSI/TIA/EIA-526- 7, Method A.1 in both directions.
- D. Fiber optic cable and connector loss shall not exceed 0.5 dB max. The Contractor is responsible for obtaining minimum loss in fiber connections and polishing per manufacturer' specifications.

**NISQUALLY STATE PARK
NEW FULL SERVICE PARK - PHASE 2**

3.11 GROUNDING

- A. Grounding shall conform to ANSI/TIA/EIA-607, National Electrical Code and manufacturer's grounding requirements at a minimum.
- B. Ground equipment racks, housing, and raceways individually.

END OF SECTION

NISQUALLY STATE PARK
NEW FULL SERVICE PARK – PHASE 2

SECTION 311100 – CLEARING AND GRUBBING

PART 1 - GENERAL

1.1 DESCRIPTION

- A. This Section includes the following but is not limited to the following: protection of existing trees, shrubs and other vegetation identified to be saved, removal of trees and other vegetation as specified, Selective Clearing, stripping topsoil, clearing and grubbing, removing above-grade improvements, removing below-grade improvements, salvaging boulders, wood chipping, and protection of all other existing improvements to remain. Work shall be in compliance with WSDOTSS 2-01 Clearing, Grubbing, and Roadside Cleanup unless otherwise modified in the section.
- B. "Type 1 Clearing" means removing and disposing of all organic material from the surface such as trees, brush, downed timber, or other organic materials. This definition applies to Bid Schedules A, B, and to C Bid Items except for the Bid Item "Roadway Improvements".
- C. "Type 2 Clearing" means cutting and disposing of trees within the Type 2 Clearing Zone in the Roadway Improvements Work corridor. This definition applies only to the Bid Item "Roadway Improvements" in Schedule B.
- D. "Type 3 Clearing" means cutting and disposing of trees and shrub trunk, branching, limbs and leaves/needles within the Type 3 Clearing Zone in the Disposal Area only. This definition applies only to the Bid Item "Roadway Improvements" in Schedule B.
- E. "Type 1 Grubbing" means removing and disposing of all vegetative matter from the existing surface and underground such as soils containing organics, sod, stumps, roots, buried logs or other organic debris. This definition applies to Bid Schedules A, B, and C Bid Items except for the Bid Item "Roadway Improvements".
- F. "Type 2 Grubbing" means removing and disposing of all organic material from the existing Roadway surface intended to receive Crushed Surfacing. This definition applies only to the Bid Item "Roadway Improvements" in Schedule B.
- G. Salvage conifer trees for use as "Landscape Logs".
- H. Cut, salvage, and delimb all Western Red Cedar trees that have a six-inch (6") or larger caliper into twelve-foot (12') lengths. Store the 6" caliper and larger Western Red Cedar 12' cut logs in neat, safe, and secure stacks in the Bus Parking area. The Contractor shall provide sufficient maneuvering space for the Owner's self-loading logging truck to access and load the Cedar logs onto the Owner's logging truck. Contractor will notify the Owner when the Cedar logs will be ready for pick-up whereupon Owner will provide Contractor 72 hours of notice of Owner's removal of Cedar logs. Owner will have 5 working days from Owner's notification to remove Cedar logs from site.
- I. "Debris" means all organic material produced by clearing and grubbing.

NISQUALLY STATE PARK
NEW FULL SERVICE PARK – PHASE 2

- J. “Selective Clearing” means the cutting of trees by the Contractor as selected by Owner.
- K. “Chipped” means trees shall be chipped in compliance with WSDOTSS 2-01.2(3).

1.2 RELATED WORK

- A. Coordinate related work specified in other parts of the Project Specifications, including, but not limited to the following:
 - 1. Section 015713 – Temporary Erosion and Sedimentation Control
 - 2. Section 312000 – Earth Moving
 - 3. Section 329113 – Mulch & Wood Chips
 - 4. Geotechnical Report

1.3 PROJECT CONDITIONS

- A. Traffic: Conduct site clearing operations to ensure minimum interference with roads, streets, walks, and other adjacent occupied or used facilities. Do not close or obstruct streets, walks or other occupied or used facilities without permission from authorities having jurisdiction.
- B. Removal of Improvements: Remove existing above grade and below grade improvements as indicated in the Contract Documents and those necessary to facilitate new construction.
- C. Protection of Existing Improvements: Provide protections necessary to prevent damage to existing improvements indicated to remain in place.
- D. Protect improvements on adjoining properties and on Owner's property.
- E. Restore damaged improvements to their original condition, as acceptable to property owners.
- F. Protection of Existing Trees and Vegetation: Protect existing trees and other vegetation indicated to remain in place against unnecessary cutting, breaking or skinning of roots, skinning or bruising of bark, smothering of trees by stockpiling construction materials or excavated materials within drip line, excess foot or vehicular traffic, or parking of vehicles by implementing the tree protection plan.
- G. Provide additional protection measures throughout the life of the Contract as follows:
 - 1. Water trees and other vegetation to remain within limits of contract work as required to maintain their health during course of construction operations.
 - 2. Vegetation Damage Control:
 - a. Protect all existing trees and vegetation to remain from foliage, trunk, and root damage.
 - b. Provide tree protection fencing and maintain existing conditions around trees, shrubs or other vegetation, and where shown on Plans to protect such areas from damage of any nature caused by construction operations.
 - c. Prior to beginning work, submit a tree protection plan prepared by a certified arborist for the existing trees to remain on site.

NISQUALLY STATE PARK
NEW FULL SERVICE PARK – PHASE 2

- H. Contractor can anticipate encountering a large quantity of cobbles and boulders through-out the work zone. Contractor can observe cobbles and boulders removed from the Phase 1 Maintenance Building sitework north and west of the existing Maintenance Building as an example of the type and size of cobbles and boulders that may be encountered.

1.4 SUBMITTALS

- A. Prior to beginning work the Contractor shall submit a tree protection plan indicating work areas, haul routes, and the existing trees and vegetation designated on Plans to remain on site.

PART 2 - PRODUCTS – PRODUCTS (NOT USED)

PART 3 - EXECUTION

3.1 TYPE 1 CLEARING

- A. Type 1 Clearing applies to all work except the work in the Schedule B Bid Item “Roadway Improvements”.
- B. General: Remove trees, shrubs, grass and other organic material, or obstructions as required to permit installation of new construction. Remove similar items elsewhere on site or premises as specifically indicated. Remove as specified herein and on Plans.
- C. Fell trees only within the area to be cleared and verify all trees to be cleared with Owner’s Representative.
- D. Leave standing any trees or native growth indicated by the Owner’s Representative.
- E. Salvage conifer trees of sufficient caliper (diameter) and length to meet the requirements of “Landscape Logs” as defined in the Plans. Salvage conifer tree trunks and cut into 20 foot lengths; quantity: 20 trunks sections., All conifer trees in excess of the “Landscape Log” requirements shall be Chipped.
- F. Protect by fencing where indicated on Plans and where directed by the Owner’s Representative, all trees or native growth from any damage caused by construction operations.
- G. Sawcut minor roots and branches of trees within ½” of rootwad/trunk indicated to remain where such roots and branches obstruct installation of new construction.
- H. All trees and branches resulting from Type 1 Clearing shall be Chipped and stored for used as “Wood Chips” in the Project.

3.2 TYPE 2 CLEARING

- A. Type 2 Clearing applies to all work in the Schedule B Bid Item “Roadway Improvements”.

NISQUALLY STATE PARK
NEW FULL SERVICE PARK – PHASE 2

- B. The intent of Type 2 Clearing is to remove trees within the Type 2 Clearing Zone except trees identified by Owner to be saved in place. These trees to remain will be identified prior to the Bidding period and Post Notice-to-Proceed period by a Blue spray paint dot 5’-7’ above the existing grade. All other trees not identified by these Blue dots and within the Type 2 Clearing Zone shall be cleanly and safely cut at the top of the root flare or one foot above the existing grade whichever is lower. Splintered cut trees are not acceptable.
- C. All trees and branches resulting from Type 2 Clearing shall be Chipped and stored for used as “Wood Chips” in the Project.

3.3 TYPE 3 CLEARING

- A. All trees and branches resulting from Type 3 Clearing shall be Chipped and stored for use as Wood Chips in the Project. It is the responsibility of the Contractor to provide sufficient quantities of “Wood Chip” from on-site Clearing operations or imported Wood Chips to fulfill plan requirements.

3.4 SELECTIVE CLEARING

- A. This work includes the trees to be selectively cleared that are located outside of the Work Area/Clearing Limits. These trees identified by Owner to be selectively cleared will be marked with Orange spray paint prior to the Bidding period and Post Notice-to-Proceed on the tree trunk approximately 5 to 7 feet above the existing grade. These Trees are not shown on the Plans but shall be assessed by the Contractor. Tree size, condition, species, quantities, orientation, and all Tree characteristics shall be assessed by the Contractor in the field prior to Bid Submission.

Trees identified by Owner to be selectively cleared shall be safely cut at the top of the root flare or one foot above the existing grade whichever is lower. Trees shall be fell in a direction that does not impact existing and contract improvements. Trees to be selectively cleared shall be fell in a position so the fallen Tree is in full contact with the existing grade and not in a hazardous position as determined by the Owner. Selectively cleared trees that have been felled in a hazardous position shall be further cut in place into tree segments so the felled tree is no longer hazardous as determined by the Owner. Selectively cleared trees are not required to be removed from the site. No part of a fallen tree shall be located within the project work zone.

3.5 TYPE 1 GRUBBING

- A. Type 1 Grubbing applies to all work except work in the Schedule B Bid Item “Roadway Improvements”.
- B. Grub to a depth of twelve inches (12”) below the existing grade per Geotechnical Report to remove all sod, grass, organic soils/material and all stumps, root wads, large roots (larger than 1” diameter), buried logs and other organic material under proposed aggregates, paving, and structures. Root wads shall be Chipped and stored on site to be used as Wood Chips in the Project. All organic soils from Type 1 Grubbing operations shall be placed in the Owner provided Disposal Area per Plans.

NISQUALLY STATE PARK
NEW FULL SERVICE PARK – PHASE 2

- C. Grub deep enough to remove all stumps, root wads, large roots (larger than 1” diameter), buried logs, organic soils, and other organic material in landscape areas.
- D. Grub all areas prior to performing excavation operations:
 - 1. As shown on Plans and where indicated by the Owner’s Representative.
 - 2. Where unsuitable material is removed, or structures built.
 - 3. Upon which embankments will be placed.

3.6 TYPE 2 GRUBBING

- A. Type 2 Grubbing applies to all Grubbing work in the Schedule B Bid Item “Roadway Improvements”.
- B. The intent of Type 2 Grubbing is to remove grass, leaves, branches, and all organic matter within the Type 2 Grubbing Zone resulting in exposure of the mineral soil in the Travel Lane and Shoulder. Surface and subsurface roots within the Type 2 Grubbing Zone are not required to be removed/grubbed.
- C. The anticipated depth of grubbing for Type 2 Grubbing is between 1”-3”.

3.7 CHIPPING OF CLEARING AND GRUBBING MATERIALS

- A. Contractor shall take possession of all cleared and grubbed organic material and process this organic material into Wood Chips meeting WSDOT section 2-01.2(3) Disposal Method No. 3 - Chipping. Wood Chips shall be Hog Fuel as processed by Tub Grinder or similar on-site processing equipment and range in size from 6 inches to ½ inch with a thickness no greater than ½”.
- B. Contractor shall coordinate the timing and location of the Chipping operation with Owner as well as the storage location of Wood Chips.

END OF SECTION

**NISQUALLY STATE PARK
NEW FULL SERVICE PARK – PHASE 2**

SECTION 312000 – EARTH MOVING

PART 1 - GENERAL

1.1 DESCRIPTION

- A. The work for this Section includes, but is not necessarily limited to the following:
Excavating, cutting, filling, backfilling, rough and finish grading, and compaction required to attain indicated grades.
- B. Excavation and removal of existing topsoil and subgrade soils to lines and grades as shown on the Plans and as directed by Owner.
- C. Compaction of subgrade soils for structures, asphalt, concrete, and crushed rock paved areas.
- D. Backfill and compaction of boulder voids and grubbed tree rootballs.
- E. Remove all materials from the site which are in excess of that required.
- F. Import all materials required to complete the work.
- G. Coordinate earthwork operations with other work of the project.
- H. Owner is furnishing the source of Common Borrow A from the Borrow Pit and Contractor is responsible for all Common Borrow A loading, transportation, installation, and compaction necessary to install Common Borrow A as defined in the Contract Documents.
- I. Process Boulders as defined herein.
- J. Develop and grade Disposal Site & Borrow Pit as defined in the Contract Documents.

1.2 RELATED WORK

- A. Coordinate related work specified in other parts of the Project Specifications, including, but not limited to the following:
 - 1. Section 015713 – Temporary Erosion and Sedimentation Control
 - 2. Section 220510 - Excavation & Backfill
 - 3. Section 311100 – Clearing and Grubbing
 - 4. Section 312100 – Borrow Pit
 - 5. Section 323253 – Landscape Boulders
 - 6. Section 331300 – Water Distribution
 - 7. Section 333300 – Sanitary Sewers
 - 8. Section 334000 - Stormwater Utilities
 - 9. Geotechnical Report

**NISQUALLY STATE PARK
NEW FULL SERVICE PARK – PHASE 2**

1.3 REFERENCES

- A. AASHTO T180 - Moisture-Density Relations of Soils Using a 10 lb. (4.54 kg) Rammer and an 18-in. (457 mm) Drop.
- B. ASTM C136 - Method for Sieve Analysis of Fine and Coarse Aggregates.
- C. ASTM D698 - Test Methods for Moisture-Density Relations of Soils and Soil-Aggregate Mixtures, Using 5.5 lb. (2.49 Kg) Rammer and 12-inch (304.8 mm) Drop.
- D. ASTM D1556 - Test Method for Density of Soil in Place by the Sand-Cone Method.
- E. ASTM D1557 - Test Methods for Moisture-Density Relations of Soils and Soil-Aggregate Mixtures Using 10 lb. (4.54 Kg) Rammer and 18-inch (457 mm) Drop.
- F. ASTM D2167 - Test Method for Density and Unit Weight of Soil in Place by the Rubber Balloon Method.
- G. ASTM D2419 - Test Method for Sand Equivalent Value of Soils and Fine Aggregate.
- H. ASTM D2434 - Test Method for Permeability of Granular Soils (Constant Head).
- I. ASTM D2922 - Test Methods for Density of Soil and Soil-Aggregate in Place by Nuclear Methods (Shallow Depth).
- J. ASTM D3017 - Test Methods for Moisture Content of Soil and Soil-Aggregate Mixtures.
- K. All Work shall comply with Washington State Department of Transportation Standard Specifications (WSDOTSS), most recent published edition at time of Bid applies.

1.4 QUALITY ASSURANCE

- A. Site Examination:
 - 1. Visit site prior to bidding to determine nature of existing site materials and other conditions affecting work.
- B. Geotechnical Report:
 - 1. Review the Geotechnical Report and determine the nature of existing soil and subsurface conditions of the work.
- C. Tolerances:
 - 1. Contractor is required to measure all subgrades and finish grades to laser level or GPS accuracy and shall provide a laser level or GPS unit on site for the Owner to use to check grades. Conduct Field Meeting with Owner prior to verify subgrade compliance prior to backfilling any subgrades.
 - 2. Subgrades: plus or minus 0.05 foot of Design elevations.
 - 3. Surfaced paving; plus or minus 0.05 foot of elevation shown on the Plans. No deviation of .05 in twenty (20) lineal feet will be accepted.

**NISQUALLY STATE PARK
NEW FULL SERVICE PARK – PHASE 2**

4. Common Borrow A subgrade; plus or minus 0.05.
5. Crushed Surfacing; plus or minus 0.05 foot.
6. Non-paved and non-crushed surfacing subgrades; plus or minus 0.10 foot.

D. Compaction:

Compact fills, exposed subgrades, and all imported aggregates to the following percentages of maximum dry density (MDD) as determined by ASTM: D 1557 or as otherwise noted:

1. Backfills beneath all buildings and structures shall be compacted to 95% of maximum density.
2. Backfills beneath crushed surfacing, concrete surfaces, and asphalt paving, is specified shall be compacted to 95% of maximum density.
3. Crushed Surfacing Top Course provided for Roadway Improvements shall be compacted to 95% of maximum density.
4. Embankments and Fill Slopes: 95% (unless otherwise noted).
5. Boulder Walls: Machine compact to 85% of maximum density.
6. Landscape areas: 85% of maximum density.

E. Compaction Tests:

1. The Owner will pay for compaction tests by an independent testing laboratory.
2. Compaction tests will be performed on the subgrade of structural fills beneath structures, crushed surfacing, and paved areas as directed by Owner.
3. All test results must indicate conformance to this specification before proceeding with related work. If, in the opinion of the Owner, subgrade or fills which have been placed are below specified density, the Contractor shall provide additional compaction and testing at his expense. The Contractor shall provide three (3) days advance notice to the Owner when tests are required to be performed.

1.5 SUBMITTALS

- A. Contractor shall provide testing and certification from a testing agency that Products described in Part 2, Products, comply with WSDOTSS and/or submit Qualified Products List per WSDOTSS 1-06.1(1) to the Owner. Submit 5-gallon sample of all Products required herein to Owner to remain on site as examples of the approved materials.

1.6 PROJECT CONDITIONS

- A. Site Information: Data in the Geotechnical Report was used for the basis of the design and are included in the Appendix. Conditions are not intended as representations or warranties of accuracy or continuity between soil explorations. The Owner will not be responsible for interpretations or conclusions drawn from this data by Contractor.
- B. Additional geotechnical test exploratory and other exploratory operations may be performed at the Contractor's option; however, no change in the Contract Sum will be authorized for such additional exploration.

**NISQUALLY STATE PARK
NEW FULL SERVICE PARK – PHASE 2**

- C. Carefully maintain benchmarks, monuments and other reference points. If disturbed or destroyed, replace as directed at the Contractor's expense.
- D. In subgrade cut situations where soil is encountered that cannot be proof rolled to a firm and unyielding condition, the Contractor shall inform the Owner immediately. Contractor shall take no further action until directed by Owner in writing.
- E. The Contractor is advised that underground utilities exist in the construction area. The general locations of these are shown on the Plans. Prior to beginning construction, the Contractor shall check and verify the location and elevation of all known lines. Any damage to existing utilities as a result of construction operation shall be promptly repaired by the Contractor at no expense to the Owner.
- F. Coordinate all traffic control with the Owner to maintain vehicular and pedestrian traffic along the frontage of Mashel Prairie Road, during construction operations. Use flagmen, barricades, warning signs, and other approved devices to maintain safety and cause the least disruption to traffic.
- G. Provide excavation plan and list of proposed equipment and methods at Pre-Construction Conference, including a schedule of earthwork activities and phasing of earthwork. The Contractor shall prepare a simple diagrammatic plan showing the proposed distribution of fill material subject to Owner approval.
- H. The Contractor may encounter a large quantity of Boulders during the earth moving work on the Phase 2 Project. The Boulders encountered during the one-acre sitework of Phase 1 have been placed to the north and west of the existing Maintenance Building (along the trail) and along the edge of the Borrow Pit. The Owner will select Boulders to be installed in the Administration Building Plaza from the existing Boulders north and west of the existing Maintenance Building (along the trail) and the Boulders from the Phase 2 earthwork. The Contractor is required to relocate the Phase 1 Boulders not used in the Administration Building Plaza from Boulder storage area along the north and west of the existing Maintenance Building (along the trail) to the Borrow Pit. The Phase 1 Boulders at the Borrow Pit will remain where is. Boulders encountered during the Phase 2 sitework are anticipated to be of similar character and quantity as encountered in Phase 1 sitework. Boulders that are encountered and not selected to be used for installation in the Administration Building Plaza shall be removed, hauled, and placed at the Owner Furnished Borrow Pit in a location determined by the Owner. The cost of excavating, loading, and hauling of all Boulders shall be considered to be incidental work to execute the earth moving. Boulders placed at the Borrow Pit area shall be placed in a manner resulting in zero movement and pose no hazards to the public as determined solely by the Owner. The location of Boulders storage area at the Borrow Pit shall be determined by the Owner.

1.7 **BARRIERS, SAFETY GUARDS AND WARNING LIGHTS**

- A. Provide for public, visitors', workers' protection, as required by the Washington State Department of Labor and Industries.

**NISQUALLY STATE PARK
NEW FULL SERVICE PARK – PHASE 2**

PART 2 - PRODUCTS

2.1 CRUSHED SURFACING BASE AND TOP COURSE

- A. Crushed Surfacing Base Course and Top Course per WSDOTSS 9-03.9(3). Mineral aggregate shall be composed of clean, uniform particulate size groups essentially free from wood waste and other deleterious materials obtained from approved material extraction quarries.

2.2 CRUSHED SURFACING TYPE A

- A. Crushed Surfacing Type A shall be 4X Dust Crushed Gravel and comply with WSDOTSS 9-03.9(3) Crushed Surfacing except it shall meet the following sieve requirements. Potential source: CalPortland, Dupont, WA, 800.750.0123.

Sieve Size	Percent Passing
3/4"	100
3/8"	80-100
No. 4	46-66
No. 40	8-24
No. 200	10.0 max.
% Fracture	75 Min.
Sand Equivalent	40 Min.

2.3 QUARRY SPALLS

- A. Shall be fractured quarry rock. Spalls shall be hard, sound, and unweathered, and shall comply with WSDOTSS 9-13.

2.4 GEOTEXTILE FABRIC

- A. Geotextile Fabric shall comply with WSDOTSS 9-33.2(1) Table 3, nonwoven Geotextile for Separation.

2.5 OWNER FURNISHED COMMON BORROW A SOURCE

- A. The source of Common Borrow A will be furnished by Owner from the Borrow Pit located within Nisqually State Park. Contractor shall excavate Common Borrow A only from the area shown on the Plans.

**NISQUALLY STATE PARK
NEW FULL SERVICE PARK – PHASE 2**

2.6 SALVAGED BOULDERS

- A. Salvaged Boulders shall range in size from One Man to Four Man Rock sizes as defined in WSDOTSS 9-13.7(1) and shall be salvaged and stockpiled for use as shown in the Plans. Boulders in excess of the Boulders required in the Plans shall be hauled and placed in the Borrow Pit in a location and safe manner as determined by the Owner.

2.7 NATIVE MATERIAL FOR TRENCH BACKFILL

- A. Native Backfill for Trench Backfill may be native material that has been processed through a 6 inch screen or Common Borrow A that has been processed through a 6 inch screen.

PART 3 - EXECUTION

3.1 GENERAL

- A. Prior to all Work in this Section, the Contractor shall become thoroughly familiar with the site conditions. Prior to site grading, any site surface water and groundwater shall be collected and routed away to a proper drainage away from the work areas in order to facilitate work and subgrade construction. Control drainage during construction to avoid getting materials excessively wet and prevent areas which hold water. Eliminate areas that hold water as required, within 48 hours of notification from the Owner.
- B. The Contractor shall be aware that on-site soils may be moisture sensitive and weather dependent. Contractor is fully responsible for scheduling and controlling earthwork operations. Perform work in such a manner as to prevent overworking and over-saturation of on-site soils. This shall include any/all precautions necessary throughout the entire work area (including access drives/haul roads/staging areas) to control surface and groundwater, to protect soils and subgrades from heavy vehicle loads, and to achieve soil moisture levels capable of achieving specified compaction. No extra compensation will be paid to the Contractor due to work performed at non-optimum times or under non-optimum conditions resulting in unsatisfactory soil conditions. The Contractor shall correct unsatisfactory conditions at no additional cost to the Owner. Contractor is responsible for managing the soil moisture conditions to maintain the constructability of soil in order to meet the construction contract schedule. No extra compensation will be paid to the Contractor for watering or aerating the subgrade, excavated areas, or fills to achieve specified compaction.
- C. Delays may occur due to inclement weather. It shall be the Contractor's responsibility to immediately notify the Owner and request an extension of completion time for justified reasons.
- D. Do not allow or cause any of the Work performed or installed to be covered up or enclosed prior to all of the required reviews, tests and approvals.
- E. Should any of the Work be so enclosed or covered up before it has been approved, the Contractor shall uncover all such Work, at no additional cost to the Owner.

**NISQUALLY STATE PARK
NEW FULL SERVICE PARK – PHASE 2**

- F. After the Work has been completely tested, inspected and approved, make all repairs and replacements necessary to restore the Work to the condition in which it was found at the time of uncovering, all at no additional cost to the Owner.

3.2 STABILIZED CONSTRUCTION ENTRANCE ACCESS

- A. The Contractor shall clear vegetation down to existing grade prior to placement of Geotextile Fabric and Quarry Spalls to construct the Stabilized Construction Entrance. Comply with Pierce County and jurisdictional agencies' requirements.

3.3 FINISH ELEVATIONS AND LINES

- A. Grades shown on the Plans are finish grades. Contractor shall derive subgrade elevations founded on Plans' finished grades; Contractor shall consult with Owner on any and all subgrade elevations unclear to Contractor.

3.4 EXCAVATION

- A. Excavate, as necessary, for Work shown on the Plans or specified herein. Remove roots, rocks, boulders, concrete and other obstructions. Allow a minimum of twelve inches of clear space between any obstruction and formwork. Leave bearing surfaces undisturbed, level and true. Obtain Owner's acceptance of subgrade prior to commencing of the next phase of work.
- B. Post Grubbing Boulders. Subsequent to grubbing operations, subsurface Boulders may be exposed in a manner unacceptable to the Owner. Owner will identify those Post Grubbing Boulders to be removed in their entirety by the Contractor. Remnant void edges will be graded smooth and the voids will be backfilled with adjacent soils.
- C. Where depressions result from, or have resulted from, the removal of surface or subsurface obstructions, open the depression to equipment working width and remove all debris and soft material, as directed by the Owner.
- D. Provide trench boxes, temporary shoring and supports appropriate to the specific conditions at all trenches, cuts, and excavations. Remove prior to backfilling and in such a manner as not to endanger structures. Design system for loading required and to prevent seepage of fines from cut slope. When excavating near footings, pavement, catch basins, utility poles or structures, provide lateral support to said features.
- E. All Excavation is unclassified and includes excavation to subgrade elevations indicated on the Plans, or as required to construct the work, regardless of character or materials and obstructions encountered, except as allowed in the provisions for Unsuitable Material; see subsection 3.06 herein.
- F. Grade top perimeter of excavation and all work areas to prevent surface water from draining into excavation. All work required to maintain positive drainage is incidental to the work.

**NISQUALLY STATE PARK
NEW FULL SERVICE PARK – PHASE 2**

- G. Notify Owner immediately of subsurface conditions that are not as noted in the Geotechnical Report and discontinue affected work in area until notified to resume work in writing by the Owner.
- H. Unauthorized excavations consist of removal of materials beyond indicated subgrade elevations or dimensions without specific written direction from the Owner. Backfill areas where unauthorized over-excavation has taken place with material specified by the Owner, and compact to specified density per subsection 1.03.D. Unauthorized excavation, as well as remedial work required, shall be at Contractor expense.

3.5 PREPARATION OF SUBGRADE – GENERAL

- A. Remove all ruts, hummocks, and other uneven surfaces by surface grading prior to placement of fill.
- B. Provide berms or channels to prevent flooding of subgrade. Promptly remove all water collecting in depressions.
- C. Where soil has been softened or eroded by flooding or placement during unfavorable weather, remove all damaged areas and re-compact per 1.03.D herein per Owner’s written direction.
- D. Final subgrades shall be crowned/sloped to establish positive drainage and shall conform to all design grades and details.

3.6 PREPARATION OF SUBGRADE - UNSUITABLE MATERIAL

- A. In subgrade situations where soil is encountered that cannot be proof rolled to a firm and unyielding condition as determined by the Owner, the unsuitable material shall be removed to depths determined by the Owner and disposed off-site. Contractor shall backfill unsuitable material void with Common Borrow A and compact to specified density per subsection 1.03.C to attain subgrade elevations.
- B. Should the subgrade soil be rendered unsuitable material as a result of the Contractor's negligence as determined by Owner, the Contractor will be required to excavate the unsuitable material to depths determined by Owner and disposed off-site. Contractor shall backfill unsuitable material void with Common Borrow A, and compact to specified density per referenced section 1.3.D at no cost to the Owner.
- C. “Contractor negligence” is defined as Contractor failing to deploy measures to protect the site from weather conditions, overworking of moisture sensitive soils, and directing drainage to moisture sensitive soils.

3.7 DEWATERING

- A. Provide and maintain at all times during construction, ample means and devices which promptly remove and dispose of all water from every source entering the excavations or other parts of the Work.

**NISQUALLY STATE PARK
NEW FULL SERVICE PARK – PHASE 2**

- B. Dewater by means which will ensure dry excavations and the preservation of the final lines and grades of bottoms of excavations.

3.8 FILL AND COMPACTION – GENERAL

- A. After subgrade compaction has been approved, spread approved fill material in loose lifts not exceeding ten (10) inches in thickness. Each lift shall be conditioned to the optimum moisture content and compacted to the specified minimum density prior to placing the next lift. Earthwork shall be performed under the observation of the Owner to ensure contract compliance.
- B. Water or aerate the fill material as necessary, and thoroughly mix to obtain a moisture content which will permit proper compaction. No extra compensation will be paid to the Contractor for watering or aerating the fill material to achieve specified compaction.
- C. Do not place, spread or compact any fill material during unfavorable weather conditions. Do not resume operations until moisture content and fill density will conform to specification requirements.
- D. Compact each soil layer to at least the minimum density specified. Repeat compaction process until plan grade and specified compaction density is attained.
- E. Compact areas not accessible to rollers or compactors with pneumatic hand tampers or other approved means. Use hand vibrators within 5'-0" of foundations and walls. No heavy compaction equipment shall be allowed adjacent to walls and foundations.
- F. During Warranty period, replace work damaged by settlement and replace slabs and pavement which develop settlement cracks, all at no additional cost to the Owner.
- G. In fill areas where grade slopes more steeply than 5H: IV (horizontal: vertical) the base of any embankment shall be tied to the firm stable subsoil by appropriate keying and benching.

3.9 BUILDINGS, PAVEMENTS, AND STRUCTURAL FOUNDATIONS:

- A. General:
 - 1. Includes all building and structural foundations, hot-mixed asphalt, cement concrete pavements, and trail surfaces.
- B. Cut:
 - 1. Contractor shall excavate an additional 6 inches from design subgrades in Cut areas and dispose of in the Disposal Area. Backfill this 6 inches with Common Borrow A and compact.

**NISQUALLY STATE PARK
NEW FULL SERVICE PARK – PHASE 2**

C. Fill:

1. Place Owner furnished Common Borrow A over compacted subgrade in loose lifts no greater than ten (10) inches in loose thickness and compact each lift to the minimum density specified herein.
2. Compact the Crushed Surfacing beneath the pavement sections and structures to the minimum density specified herein.
3. Place clean Crushed Aggregate beneath building slabs and compact to the minimum density specified herein.
4. Place Crushed Surfacing Top Course on the Roadway Improvements in one lift and compact to 95% MDD. Grade to uniform cross slope; do not crown Travel Lane.

3.10 GRADING

- A. Except as otherwise directed by the Owner, perform all rough and finish grading required to attain the elevations shown on the Plans. Provide the subgrade grading to an elevation to allow for finish materials and to achieve a smooth transition to undisturbed grades at project perimeter.

3.11 ROADWAY IMPROVEMENTS

- A. Prior to the placement of Crushed Surfacing Top Course, Owner and Contractor shall inspect the entire length of the Roadway to assure organic/vegetative matter has been removed and mineral soil is fully exposed the full width where the Crushed Surfacing Top Course will be placed in the Roadway. Contractor shall remove vegetative/organic matter noted by Owner.
- B. Contractor shall provide four inches (4”) minimum of Crushed Surfacing Top Course on the Travel Lane and Shoulders. The 4” depth shall not be an “average”, rather the minimum as measured from the highest cross section elevation of each linear foot of Roadway Improvements.
- C. Grade Shoulder edge uniformly at 4:1 slope maximum and compact.

3.12 TREATMENT AFTER COMPLETION OF GRADING

- A. Protect all areas from oversaturation and excessive vehicle loads. Perform work in such a manner as to minimize vehicle crossings.
- B. Use all means necessary to prevent erosion of freshly graded areas during construction and until such time as permanent drainage and erosion control measures have been installed.
- C. Repair at Contractor's expense, all damage and unsatisfactory conditions including wheel ruts and vehicle/equipment tracks, humps, low spots/depressions, footprints, rills, erosion, washes, debris drift piles, which may develop for any reason between the time finish grading is accepted and permanent stabilization measures have been completed.

3.13 SALVAGED BOULDERS

**NISQUALLY STATE PARK
NEW FULL SERVICE PARK – PHASE 2**

- A. Boulders meeting the definitions in Part 2 herein shall be salvaged and stored for use as indicated in the Drawings. Boulders that do not meet the size limits and are in excess of the Salvaged Boulders to be used in the Plans as defined herein shall be hauled and placed at the Borrow Pit.

3.14 WET WEATHER PROVISIONS

- A. The subsurface conditions may vary throughout the site; refer to the Geotechnical Report.
- B. Existing soils on site are likely to be susceptible to changes in water content and tend to become muddy, unstable and difficult to proof roll and compact if moisture content significantly exceeds the optimum.
- C. Performing earthwork during dry weather would reduce these problems associated with rainwater, trafficability, and handling of wet soils. Wet and potentially muddy conditions should be anticipated during subsurface excavations.

3.15 DISPOSAL OF UNACCEPTABLE MATERIALS

- A. Unacceptable excavated material including, but not limited to trash, rebar, asphalt, and concrete, and miscellaneous construction debris shall be hauled off-site and disposed of in a legal manner.

END OF SECTION

**NISQUALLY STATE PARK
NEW FULL SERVICE PARK – PHASE 2**

SECTION 312100 – BORROW PIT

PART 1 - GENERAL

1.1 SECTION INCLUDES

- A. This Section includes the work necessary to excavate and grade Common Borrow A for Phase 2 Improvements from the Owner furnished Borrow Pit.
- B. Testing for Metals and cPAHs during the Common Borrow A excavation process by Owner.

1.2 RELATED SECTIONS

- A. General Conditions
- B. Section 311100 – Clearing and Grubbing
- C. Section 312000 – Earth Moving

1.3 QUALITY ASSURANCE

- A. Owner may conduct Gradation testing of the Borrow Pit's Working Face at Owner's discretion and may direct Contractor to modify excavation operations to a different Working Face within the Borrow Pit.

PART 2 - PRODUCTS (NOT USED)

PART 3 - EXECUTION

3.1 EXAMINATION

- A. Contractor is responsible for assessing Haul Road and Borrow Pit site conditions prior to bidding.

3.2 PREPARATION

- A. Type 1 Clearing and Type 1 Grubbing shall be implemented for the Borrow Pit. Rootwads shall be processed into Wood Chips and not remain on the surface and/or buried in the Borrow Pit. Any Boulders encountered shall be safely and securely stored in the Borrow Pit in a location defined by the Owner. "Securely stored" means the Boulders shall be placed in a manner where all the Boulders shall exhibit zero movement under human pressure.

**NISQUALLY STATE PARK
NEW FULL SERVICE PARK – PHASE 2**

3.3 EXCAVATION & GRADING

- A. Contractor shall excavate the Borrow Pit's Working Face in the area shown on the Plans only unless notified otherwise by the Owner.
- B. Contractor shall take professional care to monitor the consistency of Common Borrow A. Contractor shall visually assure the material excavated meets Gravel with sand (GP) gradation (Common Borrow A). Notify Owner should Working Face material change consistency.
- C. At the end of every working day and at Final Completion, Contractor shall grade the Working Face so all slopes are at the angle of response and are safe as determined solely by the Owner.

3.4 METALS AND CARCINOGENIC AROMATIC HYDROCARBONS (cPAHs) TESTING BY OWNER

- A. The Owner has found the Borrow Pit contains various levels of lead (historical recreational shooting w/clay pigeons) and has conducted a preliminary testing assessment which can be found in the Appendix. Owner will conduct lead testing per Environmental Protection Agency Method 6020B and carcinogenic aromatic hydrocarbons (cPAHs) per Environmental Protection Agency Method 8270 in the frequency shown in the table below. Owner will take a minimum of two four-ounce samples to the testing lab for each testing occurrence. Lead and cPAHs samples selected for testing shall be taken from the processed Common Borrow A material and submitted under chain of custody to an accredited laboratory for analysis. Testing/analytical results shall be copied from the selected laboratory to Contractor and Owner simultaneously. Detected Lead Concentrations range shall be categorized as follows: <50 mg/kg (suitable for commercial fill above water table); >50-220 mg/kg (suitable for reuse as paving base material and road construction); and >220 (not suitable for reuse within the Park). The detected cPAHs concentrations range shall be categorized as follows: 0.05 - 0.1 mg/kg (suitable for commercial fill above water table); >0.1 - 2 (suitable for reuse as paving base material and road construction); and >2 (not suitable for reuse as fill within the Park). Use/reuse of the pit material should be based on parameters detailed in Table 12.1 and 12.2 Washington State Department of Ecology Pub. No. 10-09-057, Guidance for the Remediation of Petroleum Contaminated Sites, revised June 2016.

Cubic Yards of Soil	Number of Samples
0-3000	6
3001-6000	5
6001+	2

- B. Owner may conduct additional testing for copper, vanadium and zinc at the same frequency to verify that lead results can be used as a proxy indicator for these additional metals contaminants. Samples selected for testing will be taken from the processed Common Borrow A material and submitted under chain of custody to an accredited laboratory for analysis. Testing/analytical results shall be copied from the selected laboratory to Contractor and Owner simultaneously.

**NISQUALLY STATE PARK
NEW FULL SERVICE PARK – PHASE 2**

- C. Should any of the test results exceed the 220 mg/kg lead level then the Owner will immediately notify the Contractor who shall cease operations. The Owner and Contractor will immediately develop a strategy to continue operations.

3.5 SECURITY AND PROTECTION

- A. Contractor is responsible for providing Temporary Security fencing/barriers at the Mashel Prairie Road and Borrow Pit Haul Route intersection. Temporary Security Fencing shall span the opening of the Haul Route to assure unauthorized access to the Borrow Pit Haul Route.
- B. Contractor shall monitor the condition of the Borrow Pit Haul Route throughout the performance period. Contractor shall place the minimum amount of Common Borrow A to provide Haul Route in a safe, drivable, and workable condition.

END OF SECTION

**NISQUALLY STATE PARK
NEW FULL SERVICE PARK – PHASE 2**

SECTION 316216 – STEEL PILES

PART 1 - GENERAL

1.1 SUMMARY

- A. The extent and location of the driven pile work is indicated on the Drawings. The work includes the requirements for furnishing, coating, transporting, handling, and installing steel pipe piles to support Overlooks 2 and 3.
- B. Work also includes the requirements for pile tolerances, record keeping, cut-offs, inspections, pile driving analyzer (PDA) dynamic testing, PDA re-strikes, un-instrumented restrikes, and wave equation analysis of pile (WEAP) analyses.

1.2 SUBMITTALS

- A. Submit in accordance with Division 1 Section “Submittal Procedures”
- B. Product Data including:
 - 1. Material specification
 - 2. Material strength
 - 3. Member splice design

1.3 RELATED WORK

- A. Coordinate related work specified in other parts of the Project Specifications, including, but not limited to the following:
 - 1. Section 133700 – Boardwalk
 - 2. Geotechnical Report

PART 2 - PRODUCTS

2.1 PRODUCTS

- A. All steel piling shall be new, of the size and minimum length noted on the Drawings. If the Contractor elects to procure pile lengths beyond the lengths noted on the Drawings including the overdrive allowance, the additional length selected by the Contractor shall be subtracted from the pile cut-off over 10-foot quantity when calculated.
- B. Steel pipe piles shall be hot-dip galvanized for the top 15 – feet.
- C. At the Contractor’s discretion the steel pile material shall conform to one of the following

**NISQUALLY STATE PARK
NEW FULL SERVICE PARK – PHASE 2**

1. ASTM A500 Grade 46
2. ASTM A501 Grade B

2.2 PRODUCT HANDLING

- A. Piling delivered to the site shall be new and undamaged and shall be accompanied by certified test reports. The manufacturer's logo and mill identification mark shall be provided on the pipe piling as required by the referenced specifications. In addition, mark each length of the steel pipe pile as follows:
 1. Name and location of the piling manufacturer
 2. Heat number
 3. Welding process
 4. Outer diameter, nominal wall thickness, minimum wall thickness, and length
 5. Year piling was produced
- B. Before handling or transporting, inspect and verify that all piles are undamaged and free of defects. Provide specific details to the Engineer if any pile does not meet those criteria and obtain subsequent direction from the Engineer before transporting to the project site.
- C. Delivery, Handling, and Replacements
 1. Transportation, site handling, and erection shall be performed with industry standard equipment and methods, and by qualified personnel.
 2. Handle steel pipe piling by the use of bridles, strong backs, or other rigging which will prevent permanent deformations and coating damage.
 3. Piling shall be stored and handled in a manner recommended by the manufacturer to prevent permanent deflection, distortion, or damage to the piles or coating. Storage shall also be such that it facilitates inspection by the Owner.
 4. Do not damage piling during any handling and delivery operations. Handling methods shall not overstress, damage, yield, or produce impact on the units. Repair or replace all damaged piles at no cost to the Owner. Repair methods shall be approved by the Engineer prior to additional handling or driving. Piles damaged beyond repair shall be removed and replaced at no additional cost to the Owner.
- D. Storage
 1. Place stored piles so that identification marks are discernible. Separate stacked members by battens across full width of each bearing area.
 2. Store all piling on timber blocking so that the axis of each pile is maintained in a straight line and that bending stresses, misalignments, and yielding are not produced. Locate the blocking of successive tiers exactly above the blocking of the lower tiers.

END OF SECTION

**NISQUALLY STATE PARK
NEW FULL SERVICE PARK – PHASE 2**

SECTION 321216 - ASPHALT PAVING

PART 1 - GENERAL

1.1 DESCRIPTION

- A. Paving and Surfacing for this work includes:
1. Hot Mix Asphalt (HMA) Surfacing for driveway and parking paving.

1.2 RELATED WORK

- A. Coordinate related work specified in other parts of the Project Specifications, including, but not limited to the following:
1. 312000 Earth Moving
 2. Geotechnical Report
 3. 323116 Security Cantilevered Slide Gate

1.3 QUALITY ASSURANCE

- A. Submittals:
1. Submit certificates from mixing plants stating that all materials supplied conform to requirements set forth by these specifications.
 2. Truck load tickets for asphalt concrete at the time of delivery.
 3. Technical data of asphalt for tack coat.
 4. A 5-gallon sample of asphalt concrete aggregates.
 5. Soil Sterilant
- B. Samples:
- Where test samples have been taken from the asphalt concrete, new material shall be placed and compacted to conform with the surrounding area at no additional expense to the Owner.
- C. Protection:
- Provide adequate protection from damage for all paved areas including graffiti, staining and spillage, until final project acceptance. Replace all damaged work.
- D. Qualifications of Asphalt Concrete Supplier per WSDOTSS 5-04.
- E. Construction shall conform to the details, cross sections dimensions, and grades specified. All elevations and grades stakes shall be established to provide a smooth and even surface in compliance with WSDOTSS 5-04.3(13). The Contractor shall immediately notify Owner of any discrepancy of line and level.

**NISQUALLY STATE PARK
NEW FULL SERVICE PARK – PHASE 2**

1.4 WARRANTY

- A. Any settlement in asphalt paved areas which occur within the one (1) year Warranty period shall be considered to be caused by improper compaction methods and shall be corrected within thirty (30) days of notice at no cost to the Owner. Repair damage caused by settlement at no cost to the Owner.

1.5 BARRIERS, SAFETY GUARDS AND WARNING LIGHTS

- A. Provide for public, visitors', workers' protection, as required by the Washington State Department of Labor and Industries.

PART 2 - PRODUCTS

2.1 CRUSHED SURFACING

- A. Base and Top Course, Crushed Surfacing shall conform to WSDOTSS 9.03.9(3). See Section 31 20 00 Earth Moving.
- B. HMA Surfacing Type A and B
 - 1. HMA Concrete with Aggregate Grading Requirements of 1/2", as per Section 9-03.8(6) of the WSDOTSS for Roadway and Parking. Asphalt PG58-22 shall conform to Section 9-02.1(4) of the WSDOTSS. Asphalt percentage of total mixture shall be 5.0 to 7.5 percent.

2.2 TACK COAT & BLENDING SAND

- A. Tack coat shall conform to the requirements of Section 5-02.3(3) of the WSDOTSS. Blending Sand shall comply with WSDOTSS 9-03.8(4).

2.3 SOIL STERILANT

- A. Soil Sterilant shall be a non-organic water soluble herbicide "Polyborchlorate by U. S. Borax Company, Caseron, or approved equal.

2.4 HOT POURED SEALANT

- A. Hot poured sealant for bituminous pavement shall conform to WSDOTSS Section 9-04.2(1)A2 Hot Poured Sealant for Bituminous Pavement and the most recent amendments to Section 9-04.

**NISQUALLY STATE PARK
NEW FULL SERVICE PARK – PHASE 2**

PART 3 - EXECUTION

3.1 PREPARATION

- A. Subgrades: Establish subgrades to a neat, smooth surface of uniform slope per Section 31 20 00 Earth Moving and appropriate details. Subgrades shall be inspected and approved as specified prior to any paving or surfacing. Compact the subgrade to a depth of six (6) inches and three (3) feet beyond all areas to receive asphalt concrete paving.
- B. Provide Crushed Surfacing to compacted depths as shown in Plans and Section 312000 Earth Moving.
- C. Coordinate the installation of the Slide Gate Safety Loops to be installed before the asphalt paving. Saw cutting of the asphalt pavement is not permitted for the installation of the slide gate safety loops.

3.2 ASPHALT PAVING (HMA SURFACING TYPE A & B)

- A. Asphalt concrete shall be constructed in conformance with Section 5-04.3 of the WSDOTSS, except as modified herein.
- B. Install with crowning or pitched surfaces as indicated on the Plans, to provide positive drainage. The final result to be an unyielding course, free from irregularities, with a smooth, firm, tight, even surface, true to grade, line and cross section indicated. Maximum variation in the surface of the surface course 1/8" in 8' in any direction. Provide for compacted depth as indicated on the Plans.
- C. Compaction: As per paragraph 5-04.3(10) of the WSDOTSS.
- D. Maintenance: Maintain surface until final acceptance. If ruts, soft spots, or other damage occurs, repair surface at no additional cost to the Owner.
- E. Defective Work: Remove, replace defective surfaces and those which do not drain properly.
- F. Outside edges shall straight with a uniform horizontal and vertical alignment and shall be hand tooled tamped firm at a 45-degree angle.
- G. Manual paving shall be of uniform grade, slope and appearance with a smooth transition to machine laid paving.
- H. When meeting and matching with existing asphalt paving, Contractor shall sawcut the existing pavement in a straight line and remove asphalt and apply tack coat and dry Blending Sand.
- I. Adjustment of all castings, such as manhole frames and covers, catch basin frame and covers of various types of gate valves, etc. and concrete footings, slabs/curbs shall conform to the exact finished grade of new asphalt concrete pavement. After such castings have been set to final grade, they shall not be disturbed by the rolling operations. The course shall be compacted thoroughly around the perimeter of the castings and concrete by rolling with sufficient number of crisscross

**NISQUALLY STATE PARK
NEW FULL SERVICE PARK – PHASE 2**

passes around the castings and concrete with the wheel just touching the casting and concrete but not shaving or rolling over the casting and concrete.

- J. All manhole covers, inlet covers, other similar cast iron items, and concrete located in the paved area shall be left clean of all asphalt material.
- K. Ensure that each roller pass overlaps previous passes to ensure a smooth surface free of roller marks.

3.3 DEFECTIVE WORK

- A. All cost involved with correcting repairing defective work shall be borne by Contractor with no extension in the Contract period.
- B. The Contractor shall be responsible for maintaining all asphalt concrete paving until Final Acceptance of the project.

3.4 PROTECTION

- A. Execute all paving in an orderly and careful manner with due consideration for any existing and new improvements. Barricade and cover as necessary to protect pedestrian, workman, and adjacent properties.

3.5 CLEAN UP

- A. Clean up entire area of all excess materials, debris, etc., and leave project in a neat, orderly condition.

END OF SECTION

**NISQUALLY STATE PARK
NEW FULL SERVICE PARK – PHASE 2**

SECTION 321500 – CRUSHED ROCK SURFACING

PART 1 - GENERAL

1.1 RELATED DOCUMENTS

- A. Drawings and general provisions of the Contract, including General Conditions and Division 1 Specification Sections, apply to this Section.

1.2 SUMMARY

- A. This Section includes providing Crushed Rock Surfacing A for trails and pads, Gravel Backfill for Drains for pipe outlets and landscaping, and Crushed Surfacing Top Course (CSTC) For Treatment B, C & D of the Nisqually Ohop Access Road.

1.3 RELATED WORK

- A. Coordinate related work and requirements specified in other parts of the Contract Documents, including but not limited to the following:
 - 1. Section 311100 – Clearing and Grubbing
 - 2. Section 312000 – Earth Moving

1.4 REFERENCE STANDARDS

- A. Standard Specifications: All construction shall be in accordance with the "Latest Standard Specification for Road, Bridge, and Municipal Construction," prepared by the Washington State Department of Transportation (WSDOT) and the American Public Works Association, Washington State Chapter, most recent published edition at time of Bid.

1.5 SUBMITTALS

- A. Submit sieve analysis from a certified testing laboratory showing conformance to the sieve sizes listed and sample of crushed rock material (1 gallon).
- B. Submit composite data sheets on sterilant.

**NISQUALLY STATE PARK
NEW FULL SERVICE PARK – PHASE 2**

PART 2 - PRODUCTS

2.1 CRUSHED SURFACING BASE COURSE (CSBC)

- A. Crushed Surfacing Base Course: One and one-quarter inch (1 ¼”) minus base course shall meet the requirements as outlined in Section 9.03.9(3) Crushed Surfacing, of the Standard Specifications.
- B. Compacted Depth: As shown in Drawings.

2.2 CRUSHED SURFACING TOP COURSE (CSTC)

- A. Crushed Surfacing Top Course: Three quarter inch (¾”) minus top course shall meet the requirements as outlined in Section 9.03.9(3) Crushed Surfacing, of the Standard Specifications.

2.3 CRUSHED ROCK SURFACING A

- A. Crushed Rock Surfacing A: Three eighths inch (3/8”) minus crushed rock mix shall meet the requirements as outlined in Section 9.03.9(3) Crushed Surfacing, of the Standard Specifications, but shall meet the following gradation:

Sieve Size	% Passing
3/8”	100
1/4”	90-100
#10	45-50
#40	15-25
#200	8-12

- B. Compacted depth: As shown in Drawings.

2.4 GEOTEXTILE

- A. Geotextile Fabric shall comply with WSDOTSS 9-33.2(1) Table 3, nonwoven Geotextile for Separation.

**NISQUALLY STATE PARK
NEW FULL SERVICE PARK – PHASE 2**

PART 3 - EXECUTION

3.1 PREPARATION

- A. Prepare subgrade in conformance with Sections in Division 31 – Earthwork and in accordance with Section 2-06.3(1) Subgrade for Surfacing, of the Standard Specifications. Verify that the subgrade is completed to correct line and grade before installation of materials.
- B. Install Geotextile as shown on Plans. Staples to be installed as specified by manufacturer. Overlapping of Geotextile material shall be as specified by manufacturer.
- C. Install CSBC to the required depths as shown on Plans measured after compaction, in accordance with Section 4-04 of the Standard Specifications.
- D. Install CSTC to the required depths as shown on Plans measured after compaction, in accordance with Section 4-04 of the Standard Specifications.
- E. Install Crushed Rock Surfacing A to depth as described on Plans measured after compaction in accordance with Section 4-04. Compact to a firm, smooth finish.

3.2 CRUSHED ROCK SURFACING A

- A. Mark the proposed trail edge alignment with survey marking paint. New alignment shall be deep enough into adjacent landscape that all bare gravel spots will be incorporated into the area of new trail surfacing. Marked alignment shall be smooth and uniform with no noticeable irregularities, jogs or angle points. Owner shall approve marked edge alignment prior to edge cutting and sub-grade preparation.
- B. Install Crushed Rock Surfacing A to the required depths as shown on Plans measured after compaction, in accordance with Section 4-04 of the Standard Specifications.
- C. The final surface shall be an unyielding course, free from surface irregularities, with a smooth, tight, even surface, true to grade, line, and cross section shown on the Drawings and approved in field. Depth shown on Drawings is as measured after compaction. Maximum variation in any direction in the finish surface shall be a maximum of one half (1/2) inch in ten (10) feet.

END OF SECTION

**NISQUALLY STATE PARK
NEW FULL SERVICE PARK – PHASE 2**

SECTION 321600 - CURBS AND GUTTERS

PART 1 - GENERAL

1.1 SUMMARY

- A. This Section includes:
 - 1. Cement Concrete Rolled Curb
- B. Related Sections:
 - 1. Section 033010 – Cement Concrete Paving

1.2 REFERENCES

- A. Reference the following standards:
 - 1. The current WSDOT Standard Specifications for Road, Bridge, and Municipal Construction (WSDOT).
 - 2. American Society for Testing Materials (ASTM).
 - 3. American Association of State Highway and Transportation Officials (AASHTO).

1.3 QUALITY ASSURANCE

- A. A pre-installation meeting shall be held with the Owner prior to work related to this section.
- B. Concrete Standards: Comply with provisions following standards except where requirements that are more stringent as indicated:
 - 1. Section 8-04 of the WSDOT Standard Specifications.
 - 2. Concrete Manufacturer Qualifications: Manufacturer of ready-mixed concrete products complying with ASTM C94 requirements for production facilities and equipment.

1.4 SUBMITTALS

- A. General: Submit the following according to the General Provisions and Division 1 Specifications Sections of the Contract.
 - 1. Design mixes for the concrete. Include revised mix proportions when characteristics of materials, project conditions, weather, test results, or other circumstances warrant adjustments.
 - 2. Material certificates may be submitted in lieu of material laboratory test reports when permitted by the Owner. Material certificates shall be signed by the manufacturer and the Contractor certifying that each material item complies with or exceeds requirements.

**NISQUALLY STATE PARK
NEW FULL SERVICE PARK – PHASE 2**

1.5 WARRANTY

- A. Replace cracked, unsatisfactory finish work, or irregularities immediately upon notification.

PART 2 - PRODUCTS

2.1 GENERAL

- A. Cement concrete rolled curbs and sidewalks shall be air entrained concrete Class 4000 concrete conforming to Section 6-02 of WSDOT Standard Specifications.
- B. Concrete Mix: Comply with requirements of Section 5-05.3(5) of the WSDOT Standard Specification.

2.2 FORMS

- A. Forms shall be metal or wood and comply with Section 8-14.3(2) of the WSDOT Standard Specification.

2.3 CONCRETE MATERIAL

- A. Portland Cement: shall be in accordance with Section 9-01.2(1) Type 1 of the WSDOT Standard Specification. Use one brand of cement throughout project unless otherwise acceptable by Owner
- B. Fine Aggregate: shall be in accordance with Section 9-03.1(2) of WSDOT Standard Specification. Provide aggregates from a single source.
- C. Coarse Aggregate: shall be in accordance with Section 9-03.1(4) of WSDOT Standard Specification. Provide aggregates from a single source.
- D. Water: shall be in accordance with Section 9-25.1 of WSDOT Standard Specification.
- E. Admixtures: shall be in accordance with Section 9-23.6 of WSDOT Standard Specification.
- F. Curing: shall be in accordance with Section 8-14.3(4) WSDOT Standard Specification.
- G. Concrete Mixing: Comply with requirements of Section 5-05.3(5) of the WSDOT Standard Specification.
- H. Concrete shall be Class 4000.

**NISQUALLY STATE PARK
NEW FULL SERVICE PARK – PHASE 2**

PART 3 - EXECUTION

3.1 SURFACE PREPARATION

- A. Proof-roll prepared base surface to check for unstable areas and verify need for additional compaction. Do not begin work until such conditions have been corrected and are ready to receive paving.
- B. Remove loose material from compacted base surface immediately before placing concrete.

3.2 PLACING AND FINISHING

- A. Comply with the requirements of Section 8-14.3(3) of WSDOT Standard Specification.

3.3 CURING

- A. Comply with the requirements of Section 8-14.3(4) of WSDOT Standard Specification.

3.4 CONCRETE CURBS

- A. Forming: Form straight sides against wood or metal. Form tapered sides with a metal mule constructed to required section profile. Check completed formwork and screeds for grade and alignment to following tolerances:
 - 1. Top of Forms: Not more than 1/8 inch in 10 feet
 - 2. Vertical Face on Longitudinal Axis: Not more than 1/4 inch in 10 feet
- B. Mixing and Placing Concrete: Conform to the requirements for mixing and placing 4,000 psi 28-day concrete. Concrete to be placed per Section 8-04 of WSDOT Standard Specification.
- C. Joints: Expansion joints to be placed at 30 feet on center. Install so that expansion joint material is 1/4 inch below the surface of the concrete.
- D. Finish – Broom finish. Round all edges including edges formed by expansion joints.

3.5 REPAIRS AND PROTECTION

- A. Remove and replace concrete curb that is broken, damaged, or defective, or does not meet the requirements of this section.

END OF SECTION

**NISQUALLY STATE PARK
NEW FULL SERVICE PARK – PHASE 2**

SECTION 321713 – WHEEL STOPS

PART 1 - GENERAL

1.1 SECTION INCLUDES

- A. Wheel Stops for parking areas.

1.2 RELATED SECTIONS

- A. Earth Moving 312000

1.3 SUBMITTALS

- A. Submit under provisions of Section 013300 – Submittal Procedures.
- B. Product Data: Manufacturer's data sheets on each product to be used, including:
 - 1. Preparation instructions and recommendations.
 - 2. Storage and handling requirements and recommendations.
 - 3. Installation methods.

1.4 QUALITY ASSURANCE

- A. Installer Qualifications: Company with a minimum of two years documented experience in the installation of similar Work.
- B. Mock-Up: Provide a mock-up for evaluation of surface preparation techniques and application workmanship.
 - 1. Finish areas designated by Owner.
 - 2. Do not proceed with remaining work until workmanship is approved by Owner.
 - 3. Refinish mock-up area as required to produce acceptable work.

1.5 DELIVERY, STORAGE, AND HANDLING

- A. Store products in manufacturer's unopened packaging until ready for installation.

1.6 PROJECT CONDITIONS

- A. Maintain environmental conditions (temperature, humidity, and ventilation) within limits recommended by manufacturer for optimum results. Do not install products under environmental conditions outside manufacturer's recommended limits.

**NISQUALLY STATE PARK
NEW FULL SERVICE PARK – PHASE 2**

PART 2 - PRODUCTS

2.1 MANUFACTURER

A. Acceptable manufacturer:

1. Shope Concrete, which is located in: 1618 E. Main Ave, Puyallup, WA 98372-3142; Phone: (253) 848-1551 (800) 422-7560; Website: www.shopeconcrete.com
2. Puget Sound Precast, which is located in: 2206 121st St, East Tacoma, WA 984455; Phone: (253) 531-2656; Website: www.psprecast.com

2.2 MATERIALS

A. Wheel Stops shall be precast concrete, conforming to the following:

1. Nominal Size: 5 inches high, 9 inches wide, 6 feet long

B. Cement

1. ASTM C150, Portland Type I, normal, white color

C. Concrete Materials

1. ASTM C33 aggregate, water, and sand

D. Reinforcing Steel

1. ASTM A615/A615M, deformed steel bars, unfinished finish, strength and size commensurate with precast unit design

E. Air Entrainment Admixture

1. ASTM C260

F. Concrete mix

1. Minimum 5,000 psi, 28-day strength, air entrained to 5 percent to 7 percent.

G. Use rigid molds, constructed to maintain precast units uniform in shape, size, and finish. Maintain consistent quality during manufacture.

H. Embed reinforcing steel, and drill or sleeve for 2 dowels.

I. Cure units to develop concrete quality, and to minimize appearance blemishes such as non-uniformity, staining, or surface cracking.

J. Minor patching in plant is acceptable, providing appearance of units is not impaired.

K. Dowels shall be hot dip galvanized 5/8 inch bolts with mushroom heads, 18 inches long.

**NISQUALLY STATE PARK
NEW FULL SERVICE PARK – PHASE 2**

PART 3 - EXECUTION

3.1 EXAMINATION

- A. Do not begin installation until substrates have been properly prepared.
- B. If substrate preparation is the responsibility of another installer, notify Owner of unsatisfactory preparation before proceeding.

3.2 PREPARATION

- A. Clean surfaces thoroughly prior to installation.

Prepare surfaces using the methods recommended by the manufacturer for achieving the best result for the substrate under the project conditions.

3.3 INSTALLATION, GENERAL

- A. Install units without damage to shape or finish. Replace or repair damaged units.
- B. Install units in alignment with adjacent work.
- C. Fasten units in place with 2 dowels per unit.

3.4 PROTECTION

- A. Protect installed products until completion of project.
- B. Touch-up, repair or replace damaged products before Substantial Completion.

END OF SECTION

**NISQUALLY STATE PARK
NEW FULL SERVICE PARK – PHASE 2**

SECTION 321723 – PAVEMENT MARKINGS

PART 1 - GENERAL

1.1 DESCRIPTION

- A. The work includes constructing pavement markings for asphalt roadway and parking surfaces, Electric Vehicle (EV) and ADA striping in accordance with the Plans, WSDOT Standard Plans, and MUTCD.

1.2 RELATED SECTIONS

- A. Section 321216 – Asphalt Paving

1.3 STANDARD SPECIFICATIONS

- A. All work to be performed and materials to be used shall be in accordance with the current edition of the Standard Specifications for Road, Bridge, and Municipal Construction, and the current edition of the Standard Plans as published by the Washington State Department of Transportation (WSDOT), unless otherwise indicated herein.
- B. Contractor shall have one (1) copy of the Standard Specifications and all amendments therein, and applicable WSDOT Standard Plans at job site.

1.4 SUBMITTALS

- A. Contractor shall submit manufacturer's material data sheets to the Engineer, at least one (1) week prior to anticipated use.
- B. Product Data: Submit manufacturer's product data, installation instructions, standard drawings, and catalog cuts for the following:
 - 1. Painted Pavement Marking Products.
 - 2. Signage Products

PART 2 - PRODUCTS

2.1 PAINT

- A. Paint for pavement markings shall comply with WSDOTSS 9-34.1 General and 9-34.2 Paint. The paint shall be factory mixed, quick drying and non-bleeding.
- B. PAINT COLOR

**NISQUALLY STATE PARK
NEW FULL SERVICE PARK – PHASE 2**

1. All pavement marking colors shall be as indicated on the plans. In general, pavement markings shall be white except:
 - a. ADA Parking Stall symbols shall be standard blue and white per WSDOT Standard Plan M-24.60-04.
2. EV stall pavement marking colors shall be in accordance with WAC 172-100-150 Electric Vehicle Charging Stations. Colors as indicated in Drawings.

PART 3 - EXECUTION

3.1 PRELIMINARY SPOTTING

- A. Paint Pavement markings installation shall conform with Section 8-22.3 of the WSDOTSS, except that the Contractor shall be responsible for all layout and control points, striping shall not deviate more than 1/4-inch in 10 feet from a straight line and striping shall not be more than 1-inch from the specified locations.
- B. Paint striping shall only be applied after the pavement has been allowed to cure 14 days minimum, when the pavement is clean and dry and when the temperature is above 50 degrees F. Paint thickness measured above pavement shall be 15 mils. Protect from any traffic for 48 hours.

3.2 SURFACE PREPARATION

- A. All surfaces shall be prepared in accordance with WSDOT Section 8-22.3(2) PREPARATION OF ROADWAY SURFACES prior to application of pavement marking.

3.3 TOLERANCES FOR LINES

- A. Allowable tolerances for lines are as follows:
 1. Length of Line – The longitudinal accumulative error within a 40-foot length of broken line shall not exceed plus or minus 1 inch. The broken line segment shall not be less than 10 feet.
 2. Width of Line – The width of the line shall not be less than the specified line width or greater than the specified line width plus ¼ inch.
 3. Lane Width – The lane width, which is defined as the lateral width from the edge of pavement to the center of the lane line or between the centers of successive lane lines, shall not vary from the widths shown in the Contract by more than plus or minus 4 inches.
 4. Thickness – A thickness tolerance not exceeding plus 10 percent will be allowed for thickness or yield in paint and plastic material application.
 5. Parallel Lines – The gap tolerance between parallel lines is plus or minus ½ inch.
- B. Two applications of paint will be required to complete all painted pavement markings. The second application of paint shall be squarely on top of the first pass. The time period between paint applications shall meet the requirements of WSDOT Section 8-22.3(3)E.

**NISQUALLY STATE PARK
NEW FULL SERVICE PARK – PHASE 2**

C. APPLICATION THICKNESS

1. Pavement markings shall be applied to thicknesses meeting the requirements of WSDOT Section 8-22.3(3)F APPLICATION THICKNESS.

3.4 STRIPING

- A. Paint striping for parking stalls shall be four inches wide (4”), color; white.

3.5 STOP BARS

- A. Pavement marking for Stop Bars shall be white paint, 12” wide and full lane width as measured from pavement edge to center of road. Verify location with Owner.

3.6 ACCESSIBLE PARKING SYMBOL

- A. Accessible Parking Symbol shall be paint, color: blue. Symbol shall be centered on stall and oriented with the bottom of symbol in line with the end of parking stall stripe. Symbol shall conform to WSDOT M-24.60-04 Standard Plan. Contractor is required to submit paint template for Owner Approval.
- B. Handicap Parking striping shall be 4 inches wide: blue.

3.7 ELECTRIC VEHICAL CHARGING SYMBOL

- A. E-Charge Symbol shall be in accordance with WAC 172-100-150 and MUTCD federal specifications. Transpo Color-Safe Marking Paint, Bike Lane Green background or equivalent, symbol shall be white.

3.8 TRAFFIC ARROW

- A. Traffic arrows shall be paint color: white. Symbols shall be centered in the lane of travel as indicated in the plan. Symbol shall conform to WSDOT M-24.40-02

END OF SECTION

**NISQUALLY STATE PARK
NEW FULL SERVICE PARK – PHASE 2**

SECTION 321726 – DETECTABLE WARNING SURFACE

PART 1 - GENERAL

1.1 SECTION INCLUDES:

- A. Detectable Warning Surface

1.2 RELATED WORK

- A. Coordinate related work specified in other parts of the Project Specifications, including, but not limited to the following:

- 1. Section 033000 Cast-in-Place Concrete
- 2. Section 033010 Cement Concrete Paving
- 3. Section 312000 Earth Moving
- 4. Section 321216 Asphalt Paving

- B. REFERENCES

- 1. Washington State Department of Transportation Standard Specifications (WSDOTSS).
- 2. Americans with Disabilities Act (ADA) Public Right-of-Way Accessibility Guidelines
- 3. FHA Memo (5-06-02) titled Truncated Domes.

- C. SUBMITTALS

- 1. Submit under provisions of Section 013300 Submittal Procedures.
- 2. Product Data: For each type of product, submit manufacturer's literature describing products.
- 3. Shop Drawings:
 - a. Submit standard manufacturer shop drawings showing all pertinent characteristics including profile, sound on cane contact application feature, and installation method.

1.3 SAMPLES FOR VERIFICATION:

- 1. Submit two (2) tactile warning surface samples minimum 8 inch x 8 inch (203 mm x 203 mm) proposed for use.

1.4 QUALITY ASSURANCE

- A. Manufacturer: Company operating in the United States having U.S. manufacturing facility/facilities specializing in manufacturing detectable warning surface tile products with at least 5 years of experience.

**NISQUALLY STATE PARK
NEW FULL SERVICE PARK – PHASE 2**

- B. Installer Qualifications: Experienced installer with demonstrated successful experience installing detectable warning tiles on similar projects and have at least 5 years of experience.

1.5 SITE CONDITIONS

- A. Cold-Weather Placement: Comply with ACI 306.1 and as follows:
 - 1. Protect concrete work from physical damage or reduced strength that could be caused by frost, freezing actions, or low temperatures.
 - 2. When average high and low temperature is expected to fall below 40 deg F for 3 successive days, maintain delivered concrete mixture temperature within temperature range required by ACI 301.
 - 3. Do not use frozen materials or materials containing ice or snow.
 - 4. Do not place concrete on frozen subgrade or on subgrade containing frozen materials.
 - 5. Do not use calcium chloride, salt, or other materials containing antifreeze agents or chemical accelerators unless otherwise specified and approved in mixture designs.
- B. Hot-Weather Placement: Comply with ACI 301 and ACI 305.1 and as follows:
 - 1. Cool ingredients before mixing to maintain concrete temperature below 90 deg F at time of placement. Chilled mixing water or chopped ice may be used to control temperature, provided water equivalent of ice is calculated to total amount of mixing water.
 - a. Contractor's Option: Use of liquid nitrogen to cool concrete.
 - 2. Fog-spray forms, steel reinforcement, and subgrade just before placing concrete. Keep subgrade uniformly moist without standing water, soft spots, or dry areas.
- C. Grade Control: Establish and maintain required lines, grades and elevations.

1.6 WARRANTY

- A. Manufacturer agrees to repair or replace components of tactile warning surfaces that fail in materials within specified warranty period.
 - 1. Warranty includes: manufacturing defects, breakage, and deformation.
 - 2. Warranty Period: Five years from date of Substantial Completion.

PART 2 - PRODUCTS

2.1 DETECTABLE WARNING SURFACE

- A. Accessible truncated-dome detectable warning surface
 - 1. Detectable warning surface shall comply with WSDOT Standard Plan F-45.10-03.
 - 2. Cast-in-Place: configured for setting flush in new concrete walkway surfaces with slip-resistant surface treatment on domes and field of tile. Cast-in-Place tiles have a 1/4 inch

**NISQUALLY STATE PARK
NEW FULL SERVICE PARK – PHASE 2**

nominal thickness and feature embedment ribs 3 inches on center through entire length of tile.

3. Detectable warning surface shall be homogeneous, colorfast, and UV stable.
4. Color: Federal Yellow (Y) per Federal Standard 595B Table IV, Color No. 33538
5. Mounting: Permanently embedded detectable warning tile wet-set into freshly poured concrete.

B. ACCESSORIES

1. Fasteners and Anchors: Manufacturer's standard as required for secure anchorage of tactile warning surfaces, noncorrosive and compatible with each material joined, and complying with the following:
 - a. Furnish color appropriate nylon sleeve, stainless-steel fasteners for exterior use.
 - b. Fastener Heads: For nonstructural connections, use flathead or oval countersunk screws and bolts with tamper-resistant heads, colored to match tile.
2. Sealant: As recommended by manufacturer for sealing perimeter of tactile warning surfacing unit.

PART 3 - EXECUTION

3.1 GENERAL

- A. Subgrades: Establish subgrades to a neat, smooth surface of uniform slope per Section 31 20 00 Earth Moving and appropriate details. Subgrades shall be inspected and approved as specified prior to any paving or surfacing. Compact the subgrade to a depth of six (6) inches and three (3) feet beyond all areas to receive asphalt concrete paving.
- B. Place detectable warning surfacing units in dimensions and orientation indicated in Plan.

3.2 DETECTABLE WARNING SURFACE

- A. Concrete installation: comply with the installation requirements in specifications for "Concrete Sidewalks." Mix, place, and finish concrete to conditions complying with detectable warning tile manufacturer's written requirements for satisfactory embedment of tile.
- B. Tile Installation in new concrete: Follow manufacturers detailed installation guidelines.
- C. To the maximum extent possible, the Cast-in-Place Tiles shall be oriented such that the rows of in-line truncated domes are parallel with the direction of the ramp. When multiple cast-in-place tiles, regardless of size, are used the truncated domes shall be aligned between the tactile warning surface tiles and throughout the entire tactile warning surface installation.
- D. Cast-in-place tiles shall be tamped or vibrated into the fresh concrete to ensure that there are no voids or air pockets and the field level of the cast-in-place tile is flush to the adjacent concrete surface or as the drawings indicate to permit proper water drainage and eliminate tripping hazards between adjacent finishes.

**NISQUALLY STATE PARK
NEW FULL SERVICE PARK – PHASE 2**

- E. Tiles shall be cut into size and configuration indication on the drawings. Minimize any cantilever effect (to the maximum extent practicable) when cutting between successive embedment ribs as concrete will tend to flow up and over the cast-in-place tiles. The top of the body of the cast-in-place tiles shall be fully seated and flush with the adjacent concrete substrate. For specific instructions for cutting and setting refer to the manufacturer's written instructions.
- F. Clean tiles using methods recommended in writing by manufacturer.

3.3 DEFECTIVE WORK

- A. All cost involved with correcting repairing defective work shall be borne by Contractor with no extension in the Contract period.
- B. The Contractor shall be responsible for maintaining all asphalt concrete paving until Final Acceptance of the project.

3.4 CLEAN UP AND PROTECTION

- A. Protect detectable warning tiles against damage during construction period to comply with tile manufacturer's specifications.
- B. During and after the detectable warning tiles installation and the concrete curing stage, it is imperative that there are no walking, leaning, or external forces placed on the tile to rock the tile, causing a void between the underside of the tile and the concrete substrate.
- C. Remove protective plastic sheeting from detectable warning tiles within 24 hours of installation.
- D. Clean tiles not more than four days prior to date schedule for inspection intended to establish date of substantial completion in each area of the project.
- E. Clean up entire area of all excess materials, debris, etc., and leave project in a neat, orderly condition.

END OF SECTION

**NISQUALLY STATE PARK
NEW FULL SERVICE PARK – PHASE 2**

SECTION 323100 – LANDSCAPE LOGS

PART 1 - GENERAL

1.1 SECTION INCLUDES

- A. Landscape Logs

1.2 RELATED SECTIONS

- A. Section 311100 – Clearing and Grubbing
- B. Section 312000 Earth Moving
- C. Section 321500 Crushed Rock Surfacing
- D. Section 329113 Mulch & Wood Chip
- E. Section 329119 Topsoil Placement & Grading
- F. Section 329300 Plants

1.3 QUALITY ASSURANCE

- A. Installer Qualifications: All products listed in this section are to be installed by a single installer with a minimum of five years demonstrated experience in installing products of the same type and scope as specified.
- B. Mock-Up: Provide a mock-up for evaluation of surface preparation techniques and application workmanship.
 - 1. Locate mock-up in location as directed by the Engineer.
 - 2. Do not proceed with remaining work until workmanship are approved by Engineer.
 - 3. Mock-up area may become part of finished work.

1.4 STORAGE, AND HANDLING

- A. Store products under cover and in a dry location and protect from contamination, dampness, freezing or overheating.

1.5 PROTECTION

- A. Protect all work installed under this section from any cause whatsoever, including subsequent construction activities and vandalism until final acceptance.

**NISQUALLY STATE PARK
NEW FULL SERVICE PARK – PHASE 2**

PART 2 - PRODUCTS

2.1 LANDSCAPE LOGS

- A. Landscape Logs to be used shall be salvaged from site clearing as shown on Plans.
- B. Landscape Logs shall be Douglas Fir or Western Red Cedar trees only.

PART 3 - EXECUTION

3.1 LANDSCAPE LOGS

- A. Install landscape logs so that logs are firmly stable and do not rock or move when someone sits, stands, jumps, or walks on the log.
- B. Landscape logs are to have all branches and snags cut off even with surface of the bark as indicated in drawing. Branches and snags cut are to be disposed of in the one site disposal area.
- C. Landscape logs are to be installed in locations as shown on the drawing. The side of the log with the least blemish and damage will be face up, the side with the most damage will be facing down.
- D. Landscape Logs are to be buried a minimum of 1/4 of the logs diameter the full length of the log.
- E. Create a berm on both ends of log that will cover 1/2 the diameter of both ends as indicated in drawing. The berm shall smoothly feather into the landscape with no harsh or unnatural transitions.

3.2 CLEANING

- A. Clean any deleterious material from the logs.
- B. Clean up and remove all debris from the entire work area prior to final completion.

END OF SECTION

**NISQUALLY STATE PARK
NEW FULL SERVICE PARK – PHASE 2**

SECTION 323113 – CHAIN LINK FENCING

PART 1 - GENERAL

1.1 SUMMARY

A. Section Includes:

1. Scope of work. This Section includes providing new galvanized chain link Framing fencing, barbed wire, and accessories.

1.2 RELATED WORK

A. Coordinate related work specified in other parts of the Project Specifications, including, but not limited to the following:

1. Section 312000 – Earth Moving
2. Section 329113 – Mulch & Wood Chip
3. Section 329119 – Topsoil Placement & Grading

1.3 SUBMITTALS

- A. Shop Plans: Layout of fences with dimensions, details, and finishes of components, accessories, and post foundations.
- B. Product data: Manufacturer’s catalog cuts indicating material compliance and specified options.

1.4 REFERENCE STANDARDS

- A. ASTM F 567-07 Standard Practice for Installation of Chain Link Fence
- B. ASTM F 626-06 Standard Specification for Fence Fittings
- C. ASTM F 1043-08 Standard Specification for Strength and Protective Coatings on Steel Industrial Chain Link Fence Framework
- D. ASTM F 1553-06 Standard Guide for Specifying Chain Link Fence
- E. ASTM A653 / A653M - 08 Standard Specification for Steel Sheet, Zinc-Coated (Galvanized) or Zinc-Iron Alloy-Coated (Galvannealed) by the Hot-Dip Process
- F. ASTM A924 / A924M - 08a Standard Specification for General Requirements for Steel Sheet, Metallic-Coated by the Hot-Dip Process
- G. ASTM F 1083-04 Standard Specification for Pipe, Steel, Hot Dipped Zinc-Coated (Galvanized) Welded, for Fence Structures

**NISQUALLY STATE PARK
NEW FULL SERVICE PARK – PHASE 2**

- H. CLFMI SFR 2445 Security Fence Recommendations
- I. CLFMI CLF TPO211 Tested and Proven Performance of Security Grade Chain Link Fence Systems
- J. CLFMI WLG2445 Chain Link Fence Wind Load Guide for the Selection of Line Post and Line Post Spacing

1.5 QUALITY ASSURANCE

- A. Manufacturer: Company operating in the United States having U.S. manufacturing facility/facilities specializing in manufacturing chain link fence products with at least 5 years of experience.
- B. Fence contractor: Company with demonstrated successful experience installing similar projects and products in accordance with ASTM F567 and have at least 5 years of experience.
- C. Tolerances: Current published edition of ASTM specifications tolerances apply. ASTM specification tolerances supersede any conflicting tolerance.

PART 2 - PRODUCTS

2.1 MANUFACTURER

- A. Obtain chain link fences including accessories, fittings, and fastenings from a single source.
- B. Approved Manufacturer: Master Halco or approved equal.

2.2 CHAIN LINK FENCE FABRIC

- A. Steel Chain link Fabric: Provide fabric fabricated in one-piece widths. Comply with Chain Link Fence Manufacturers Institute "Product Manual" and with requirements indicated below:
 - 1. Mesh and Wire Size: 2-inch mesh, 9 gauge (0.148-inch diameter) where specified on Plans.
 - 2. Galvanized with 2.0 oz. per square foot on wire.
 - 3. Knuckled selvage top and bottom.

2.3 STEEL FENCE FRAMING

- A. All Steel Framing shall comply with Table 3, Group IC of ASTM F 1043-08
- B. FABRIC BANDS: Fasten fabric to line post, top rail, mid rail, and bottom rail at 15” intervals.
- C. POST TOPS: All posts shall be equipped with heavy malleable, cast iron or pressed steel, galvanized and designed as to exclude moisture from post. Post tops shall be rounded with no

**NISQUALLY STATE PARK
NEW FULL SERVICE PARK – PHASE 2**

sharp protrusions. Install tops on line posts which permit passage of top rail. End Post tops shall have a cut and fitted round plate of corresponding thickness of pipe welded flat.

- D. END, CORNER AND TERMINAL POSTS: Terminal posts shall be 2.875-in OD, Group IC Pipe per ASTM F 1043-08 or Schedule 40 pipe galvanized in accordance with A.S.T.M. Designation A-120. Corner posts shall be placed when the line of fence changes direction 20 or more degrees.
- E. TERMINAL POST AT TEMPORARY FENCE: Terminal posts shall be 4-in. OD, Group IC Pipe per ASTM F 1043-08 or Schedule 40 pipe galvanized in accordance with A.S.T.M. Designation A-120. Located per Plan.
- F. PULL POSTS: Pull posts shall be placed not over 1500' apart in each line of fence or when a grade change of more than 20 degrees occurs.
- G. INTERMEDIATE (Line) POSTS: Line posts shall be 2.375 in. OD, Group IC Pipe per ASTM F 1043-08 or Schedule 40 pipe galvanized in accordance with A.S.T.M. Designation A-120.
- H. TOP AND BOTTOM RAIL: Shall be 1.66" O.D., Group IC Pipe per ASTM F 1043-08 or Schedule 40 pipe galvanized in accordance with A.S.T.M. Designation A-120. Top rail shall form a continuous brace from terminal post to terminal post in each line of fence and shall be securely held in place at the terminals, with bands and cups or a positive receptacle pocket.
- I. TERMINAL POST BRACING: Terminal post brace sections shall adjustable steel truss rods. Brace is to be installed between the top rail and the grade line and is to extend from the terminal post to the first adjacent line post. Braces shall be securely attached to the terminal and line posts with bands and cups or at the terminal with a positive receptacle pocket and at the line post with a tamper-proof staple attachment.

2.4 ACCESSORIES

- A. Chain link fence accessories per ASTM F 626: Provide items required to complete fence system. Galvanize each ferrous metal item and finish to match framing.
- B. Top Rail and Brace Rail Ends: Pressed steel per ASTM F626, for connection of rail and brace to terminal posts.
- C. Top Rail Sleeves: 7" (178 mm) expansion sleeve with spring, allowing for expansion and contraction of top rail.
- D. Wire Ties: 9 gauge [0.148" (3.76 mm)] galvanized steel wire for attachment of fabric to line posts. Double wrap 13 gauge [0.092" (2.324 mm)] for rails and braces. Hog ring ties of 11 gauge for attachment of fabric to tension wire.
- E. Brace and Tension (stretcher bar) Bands: Pressed steel.
- F. Tension Bars: One-piece lengths equal to 2 inches (50 mm) less than full height of fabric with a minimum cross-section of 3/16" x 3/4" (4.76 mm x 19 mm) or equivalent fiber glass rod. Provide tension (stretcher) bars where chain link fabric meets terminal posts.

**NISQUALLY STATE PARK
NEW FULL SERVICE PARK – PHASE 2**

- G. Tension Wire: Galvanized coated steel wire, 7 gauge, [0.177"(4.5 mm)] diameter wire with tensile strength of 75,000 psi (517 MPa).
- H. Truss Rods & Tightener: Steel rods with minimum diameter of 5/16" (7.9 mm). Capable of withstanding a tension of minimum 2,000 lbs.
- I. Nuts and bolts are galvanized.

2.5 COATING

- A. Chain Link Fencing Fabric: Hot dipped galvanized.
- B. Steel Fence Framing: Standard weight schedule 40; minimum yield strength of 30,000 psi (205 MPa); sizes as indicated. Hot-dipped galvanized with minimum average 1.8 oz/ft² (550 g/m²) of coated surface area (0.30 mil).
- C. Fencing Accessories: Provide items required to complete fence system. Galvanize each ferrous metal item and finish to match framing.

2.6 SETTING MATERIALS

- A. Concrete: Minimum 28-day compressive strength of 4500 psi (20 MPa).
- B. Hand mixing of concrete will be permitted on batches under one (1) cubic yard. All batches exceeding this volume shall be machine mixed.

PART 3 - EXECUTION

3.1 EXAMINATION

- A. Verify areas to receive fencing are completed to final grades and elevations.

3.2 CHAIN LINK FENCE FRAMING INSTALLATION

- A. Install chain link fence in accordance with ASTM F 567 and manufacturer's instructions.
- B. Locate terminal post at each fence termination and change in horizontal or vertical direction of 30° or more.
- C. Locate Terminal Post at Temporary Fence at the transition to temporary security fencing, locate per plan.
- D. Check each post for vertical and top alignment and maintain in position during placement and finishing operations.

**NISQUALLY STATE PARK
NEW FULL SERVICE PARK – PHASE 2**

- E. Tension Wire: Provide a continuous tension wire at the mid-point of fencing where shown on Plans. Install tension wire before stretching fabric and attach to each post with ties. Secure tension wire to fabric with 11 gauge [0.0985” hog rings 24” (610 mm) on center.
- F. Bottom Rail: Install 1.66 in. OD bottom rails continuous, where shown on Plans. Set bottom edge of rail at 2 in. clear of finish grade.
- G. Post Spacing: Posts shall be evenly spaced in the line of fence on a maximum of 9-foot center unless otherwise noted.
- H. Concrete: Concrete for post foundations shall be Class 4500 (4500 psi) concrete mixture.
- I. Locate fence posts and install fence fabric in a manner so that the clearance between the twisted selvage and the finish grade of the mulch is not greater than one inch (1”).

3.3 CHAIN LINK FABRIC INSTALLATION

- A. Fabric Install fabric on the side indicated on Plans. Attach so that fabric remains in tension after pulling force is released. Bottom of fabric selvage shall be one inch (1”) from finish grade. Attach fabric with wire ties to line posts at 15” on center and to rails and braces. Attach fabric with Hog Rings to tension wire at 24” (600 mm) on center.
- B. Tension (stretcher) bars: Pull fabric taut; thread tension bar through fabric and attach to terminal posts with bands or clips spaced maximum of 15” (381 mm) on center.

3.4 ACCESSORIES

- A. Tie wires: Bend ends of wire minimum two times around fabric. Single folding of tie ends is not acceptable under any circumstances. Assure clipped ends do not protrude beyond the fence fabric and face away from the fabric side of fence to minimize hazard to persons and clothing.
- B. Fasteners: Install nuts on side of fence opposite fabric side for added security.

3.5 NUTS AND BOLTS

- A. Carriage bolts for fitting shall be installed with the nut on the secure side of the fence. All bolts shall be peened secure.

3.6 CLEANING

- A. Clean up debris and unused material. Completely remove all concrete, mud, and dirt from posts, fabric, and fittings. Police all wire ties, clipped metals, and fencing related debris and remove from the site.
- B. All excess concrete shall be disposed of off-site.

END OF SECTION

**NISQUALLY STATE PARK
NEW FULL SERVICE PARK – PHASE 2**

SECTION 323116 - SECURITY CANTILEVERED SLIDE GATES

PART 1 - GENERAL

1.1 DESCRIPTION

- A. The work in this section shall include furnishing all labor, materials, equipment, and appliances necessary to complete construction of all Security Cantilevered Slide Gates and Slide Gate Operators (also known as Hydraulic Gate Operators) required for this project in strict accordance with this specification section and drawings.
- B. References used below, and in other instances in this Section, are generally accepted industry standards. The edition of the criteria cited shall be the most recent published edition, including amendments, at the time of bid.

1.2 REFERENCES

- A. Underwriters Laboratory Gate Operator Requirements (UL 325).
 - 1. Operators shall be built to UL325 standards and be listed by a testing laboratory. Complete all electrical work according to local codes and National Electrical code. All fieldwork shall be performed in a neat and professional manner, completed to journeyman standards.
 - 2. Current safety standards require the use of multiple external sensors to be capable of reversing the gate in either direction upon sensing an obstruction. Also see 2.02 D.
 - 3. Vehicle gates should never be used by pedestrians. Separate pedestrian gates must always be provided when foot traffic is present.
 - 4. Current safety standards require gate operators to be designed and labeled for specific usage classes. Hydraulic Operator 222 E ST gate operators are to be used on Classes I, II, III and IV installations.
- B. ASTM F 2200 - Standard Specification for Automated Vehicular Gate Construction.
- C. ASTM F 1184 - Standard Specification for Industrial and Commercial Horizontal Slide Gates, Type II, Class 2.
- D. American Welding Society AWS D1.2 Structural Welding Code.

1.3 SUBMITTAL

- A. Product Data:
 - 1. Provide manufacturer's catalog cuts with printed specifications and installation instructions.
 - 2. Deliver two (2) copies of operation and maintenance data covering the installed products, including name, address and telephone number of the nearest fully equipped service center.

**NISQUALLY STATE PARK
NEW FULL SERVICE PARK – PHASE 2**

3. Each operator shall bear a label indicating that the operator mechanism has been tested for full power and pressure of all hydraulic components, full stress tests of all mechanical components and electrical tests of all overload devices.
- B. Shop drawings:
1. Supply shop drawings showing the relationship of operating systems with gate components, including details of all major components.
 2. Include complete details of gate construction, gate height and post spacing dimensions.
- C. Certification of Performance Criteria:
1. Manufacturer of gate system shall provide certification stating the gate system includes the following material components that provide superior performance and longevity. Alternate designs built to minimum standards that do not include these additional structural features shall not be accepted.
 - a. Gate track system shall be keyed to interlock into gate frame member (providing 200% additional strength when compared to weld only keyless systems). When interlocked with and welded to the "keyed" frame top member, gate track forms a composite structure.
 - b. Gate shall have a minimum counterbalance length of 50% opening width which provides a 36% increase in lateral resistance (when compared to ASTM minimum of 40% counterbalance). If gate is ever to be automated, counterbalance section shall be filled with fabric or other specified material.
 - c. To provide superior structural integrity, intermediate vertical members shall be used - with spacing between verticals to be less than 50% of the gate frame height.
 - d. Entire gate frame (including counterbalance section) shall include 2 adjustable stainless or galvanized steel cables (minimum 3/16") per bay to allow complete gate frame adjustment (maintaining strongest structural square and level orientation).
 - e. Gate truck assemblies shall be tested for continuous duty and shall have precision ground and hardened components. Bearings shall be pre-lubricated and contain shock resistant outer races and captured seals.
 - f. Gate truck assemblies shall be supported by a minimum 5/8" plated steel bolt with self aligning capability, rated to support a 2,000 # reaction load.
 - g. Hanger brackets shall be hot dipped galvanized steel with a minimum 3/8" thickness that is also gusseted for additional strength.
 - h. Gate top track and supporting hangar bracket assemblies shall be certified by a licensed professional engineer to withstand a 2,000 lb. vertical reaction load without exceeding allowable stresses.
 - i. Gate is to be designed to meet specified ASCE-7 wind load requirements with the gate in the closed and latched condition only. Typical gate design is expected to operate satisfactorily in winds up to 30 MPH. Depending on gate panel infill, winds higher than 30 MPH may cause gate operational problems (if automated, operator entrapment may trigger; gate panel may not engage receiver). For sites with higher operational, non-typical, or specified wind loadings, manufacturer should be advised of the site conditions and a specifically engineered design will be offered.
- D. Certifications:
1. The Structural Cantilever Slide Gate must be cycle-tested and certified per section 2.04 B.

**NISQUALLY STATE PARK
NEW FULL SERVICE PARK – PHASE 2**

2. The aluminum welders and welding process for gate manufacture must be certified per section 2.04 C.
3. Operator Manufacturer: A company specializing in the manufacture of hydraulic gate operators of the type specified, with a minimum of ten years' experience.
4. Manufacturer shall supply gate design performance certification as per section 1.03 C.

PART 2 - PRODUCTS

2.1 SLIDE GATE OPERATOR (HYDRAULIC GATE OPERATOR)

- A. Slide Gate Operator (Hydraulic Gate Operator) shall be SlideDriver 40 (222 E ST) with Smart Touch Controller as manufactured by HySecurity (Phone: 800-321-9947) or approved equal.
- B. Operation shall be by means of a metal rail passing between a pair of reinforced composite wheels with polyurethane treads. Operator motors shall be hydraulic, geroller type, and system shall not include belts, gears, pulleys, roller chains or sprockets to transfer power from operator to gate panel. The operator shall generate a minimum horizontal pull of 300 lb (136 kg) without the drive wheels slipping and without distortion of supporting arms. Operator shall be capable of handling gates weighing up to 4,000 lb (1,814 kg). Gate panel velocity shall not be less than 1 ft/s (304 mm/s) and shall be stopped gradually to prevent shock loads to the gate and operator assembly. The "soft-stop" feature of the gate operator shall be controlled by two adjustable hydraulic brake valves (one for each direction).
- C. Standard mechanical components shall include as a minimum:
 1. Supporting arms: Cast aluminum channel. Arms shall incorporate a fully bushed, 1 1/2" (38 mm) bronze bearing surface, acting on arm pivot pins. (item 2 below)
 2. Arm pivot pins: 3/4" (19 mm) diameter, stainless steel, with integral tabs for ease of removal.
 3. Tension spring: 2 1/2" (63 mm) heavy duty, 800 lb (363 kg) capacity.
 4. Tension adjustment: Finger tightened nut, not requiring the use of tools.
 5. Drive release: Must instantly release tension on both drive wheels and disengage them from contact with drive rail in a single motion, for manual operation.
 6. Limit switches: Fully adjustable, toggle types, with plug connection to control panel.
 7. Chassis: 1/4" (6 mm) steel base plate, and 12 Ga. (3 mm) sides and back welded and ground smooth.
 8. Cover: 16 Ga. (1 mm) zinc plated steel with textured TGIC polyester powder coat finish. All joints welded, filled and ground smooth. Finished corners square and true with no visible joints.
 9. Finish: Zinc plated steel with textured TGIC polyester powder coat finish, proven to withstand 1,000 hour salt spray test.
 10. Drive wheels: Two 6" diam (152 mm) AdvanceDrive wheels. High-strength composite hub with polyurethane over mold.
 11. Drive rail: Shall be extruded 6061 T6, not less than 1/8" (3 mm) thick. Drive rail shall incorporate alignment pins for ease of replacement or splicing. Pins shall enable a perfect butt splice.
 12. Hydraulic hose: Shall be 1/4" (6 mm) synthetic, rated to 3,000 psi (20.6 MPa).
 13. Hydraulic valves: Shall be individually replaceable cartridge type, in an integrated hydraulic manifold.

**NISQUALLY STATE PARK
NEW FULL SERVICE PARK – PHASE 2**

14. Hose fittings: At manifold shall be quick-disconnect type, others shall be swivel type.
15. Hydraulic fluid: High performance type with a viscosity index greater than 375 and temperature range -40° F to 158° F (-40° C to 70° C).
16. A zero to 2,000 psi (13.7 MPa) pressure gauge, mounted on the manifold for diagnostics, shall be a standard component.
17. The hydraulic fluid reservoir shall be formed from a single piece of metal, non-welded, and shall be powder painted on the inside and the outside, to prevent fluid contamination.

D. Minimum standard electrical components:

1. Pump motor: 1 hp, 3450 RPM, 56C, TEFC. Standard voltages available in single or three phase.
2. All components shall have overload protection.
3. Electrical enclosure: Type 1, metal, with hinged lid gasketed for protection from intrusion of foreign objects.
4. Controls: Smart Touch Controller Board containing:
 - a. inherent entrapment sensor;
 - b. built in audible “warn before operate” system;
 - c. built in timer to close;
 - d. 32 character OLED display for reporting of functions and codes;
 - e. multiple programmable output relay options;
 - f. anti-tailgate mode;
 - g. built-in power surge/lightning strike protection;
 - h. menu configuration, event logging and system diagnostics easily accessible with a PC and HySecurity’s free Smart Touch Analyze and Retrieve Tool;
 - i. RS-232 port for connection to laptop or other computer peripheral and RS-485 connection for network interface.
 - j. Dual gate communication connection for bi-parting, sally port, or sequenced gates.
 - k. Electromechanical and solid state relays.
 - l. Radio option outputs.
 - m. 21 inputs for site specific configurations.
5. Transformer: 75 VA, non-jumpered taps, for all common voltages.
6. Control circuit: 24VDC.
7. Power: 208 VAC single phase

E. Obstruction Sensing Systems:

1. The inherent motor current sensors are part of the gate operator system and may not be removed or bypassed.
2. Required external sensors: See 1.02 B2. EMX IRM-MON Photo Eyes and ASO Edge Sensor, or approved equals, to be installed such that the gate will reverse in either direction upon sensing an obstruction. All safety devices conform to the UL 325 approved safety devices for HySecurity operators.

F. Additional control devices:

1. Radio control: Inti Transmitters (Model: INTI2/A) and OXI/A Receiver or approved equal. Provide one (1) OXI/A Receiver per slide gate ophydraulic gate operator and (3) Inti

**NISQUALLY STATE PARK
NEW FULL SERVICE PARK – PHASE 2**

Transmitters per hydraulic gate operator. Intii transmitters shall be color-coded by gate. Submit product cutsheet to Owner for color selection during shop drawing process.

2. Fire Box with Knox Keyswitch: Security Bran 15-013 Fire box with Knox keyswitch or approved equal, emergency vehicle open device to be installed as dictated by local code.
3. Key operated cable manual release (secure side of gate).
4. Detection Loops: HY5B automatic loop detector assembly or approved equal.
5. Card Readers: Card reader per Drawings.

2.2 FACTORY TESTING

- A. Fully assemble and test, at the factory, each gate operator to assure smooth operation, sequencing, and electrical connection integrity. Apply physical loads to the operator to simulate field conditions. Tests shall simulate physical and electrical loads equal to the fully rated capacity of the operator components.
- B. Check all operator mechanical connections for tightness and alignment. Check all welds for completeness and continuity. Check welded corners and edges to assure they are square and straight.
- C. Inspect operator painted finish for completeness and gloss. Touch up imperfections prior to shipment.
- D. Check all hydraulic hoses and electrical wires to assure that chafing cannot occur during shipping or operation.

2.3 SECURITY CANTILEVER SLIDE GATE MANUFACTURERS

- A. The cantilever sliding gate shall be manufactured by Tymetal Corp., 678 Wilbur Avenue, Greenwich, NY 12834 (Phone: 800-328-4283), or approved equal.
- B. Cantilever Slide Gate manufacturer shall submit test results upon request stating that the gate panel has been tested in an operated system for 200,000 cycles.
- C. Gate manufacturer shall provide independent certification as to the use of a documented Welding Procedure Specification and Procedure Qualification Record to insure conformance to the AWS D1.2 welding code. Upon request, Individual Certificates of Welder Qualification documenting successful completion of the requirements of the AWS D1.2 code shall also be provided.

2.4 SECURITY CANTILEVER SLIDE GATE

- A. Security Cantilever Slide Gate System dimensions shall be as shown on the detail drawings.
- B. Structural Gate Frame:
 1. The gate frame shall be fabricated from 6063-T6 aluminum alloy extrusions. The top member shall be a 3" x 5" aluminum structural channel/tube extrusion weighing not less than 3.0 lb/lf (4.4kg/m). To maintain structural integrity this frame member shall be "keyed" to interlock with the "keyed" track member. If fabricated as a single horizontal

**NISQUALLY STATE PARK
NEW FULL SERVICE PARK – PHASE 2**

piece, the bottom member shall be a 2" x 5" aluminum structural tube weighing not less than 2.0 lb/lf. If fabricated in two horizontal pieces, the bottom member shall be a 5" aluminum structural channel weighing not less than 2.65 lb/lf, and the two horizontal pieces or sections shall be spliced in the field (the gate frame shall be fabricated in one or multiple sections depending on size requirements or project constraints).

2. Vertical Members:

- a. The vertical members at the ends of the opening portion of the frame shall be "P" shaped in cross section with a nominal base dimension of no less than 2" x 2" (51mm x 51mm) and weighing not less than 1.6 lb/lf (2.3kg/m). The intermediate vertical members shall alternate between 2" x 2" (51mm x 51mm) and 1" x 2" (25mm x 51mm) in cross section weighing not less than 1.1 lb/lf (1.6kg/m) and 0.82 lb/lf (1.2kg/m) respectively.
- b. Intermediate 1" x 2" (25mm x 51mm) vertical members weighing not less than .82 lb/lf shall alternate between 2" x 2" major members.

C. Splicing:

1. A 1/4" x 5" x 24" galvanized steel splice plate shall be used to secure the two bottom channel members together utilizing eight (8) plated carriage bolts with lock nuts. The top members will be spliced together using a 1/4" x 2" x 24" aluminum splice plate secured with six (6) drive rivets on one side and welded to the top member on the other side. The track is overlapped onto the opposing section in an alternating fashion, interlocking with the top primary member.

D. Gate Track:

1. The gate shall have a separate semi-enclosed "keyed" track, extruded from 6005A-T61 or 6105 T5 aluminum alloy, weighing not less than 2.9 lb/lf. Track members are to be located on each side of the top member. When interlocked and welded to the "keyed" top member, it forms a composite structure with the top of the gate frame. Welds are to be placed alternately along the top and side of the track at 9" centers with welds being a minimum of 2" long.

E. All welds on the gate frame shall conform to Welding Procedure Specification and Procedure Qualification Record to insure conformance to the AWS D1.2 Structural Welding Code. All individual welders shall be certified to AWS D1.2 welding code. See 1.02 D.

F. Gate Mounting:

1. The gate frame is to be supported from the track by four (4) swivel type, self-aligning, 4 wheeled, sealed lubricant, ball-bearing truck assemblies.
2. The bottom of each support post shall have a bracket equipped with a pair of 3" (76mm) UHMW guide wheels. Wheel cover protectors shall be included with bottom guides to comply with UL325.
3. Gap protectors shall be provided and installed, compliant with ASTM F 2200.

G. Diagonal Bracing:

1. Diagonal "X" bracing of 3/16" or 1/4" diameter stainless or galvanized steel cable shall be installed throughout the entire gate frame.

**NISQUALLY STATE PARK
NEW FULL SERVICE PARK – PHASE 2**

H. Gate Panels:

1. Gate Panels shall be provided by the Owner and installed by the Contractor.

I. Posts:

1. Double sets of support posts shall be minimum 4" O.D. (102mm) round SS40 or 4" x 4" x 3/16" wall square steel tubing, grade 500. Gate posts shall be galvanized or coated and supported in concrete footings as specified by the design team.

J. Finish:

1. Gate to be mill finish aluminum.

K. Gate Lock:

1. Gate system shall be furnished with a secure gate catcher. The catcher shall prevent the gate panel from being pried open while the gate is in the closed and locked position.

PART 3 - EXECUTION

3.1 SITE INSPECTION

- A. Final grades and installation conditions shall be examined. Installation shall not begin until all unsatisfactory conditions are corrected.
- B. Locate concrete mounting pad in accordance with approved shop drawings.
- C. Make sure that gate is level and operating smoothly under manual conditions before installation of gate operators. Do not proceed until gate panel is aligned and operates without binding.

3.2 INSTALLATION

- A. Equipment in this section shall be installed in strict accordance with the manufacturer's printed instructions, current at the time of installation (unless otherwise shown on the contract drawings).
- B. Coordinate locations of operators with contract drawings, other trades and shop drawings.
- C. Installer shall insure that the electric service to the operator is at least 20 AMPS. Operator wattage is 1500.
- D. The gate and installation shall conform to:
 1. ASTM F 1184 standards for aluminum cantilever slide gates, Type II, Class 2.
 2. ASTM F 2200 standard specification for automated vehicular gate construction.
 3. UL325 standards.
- E. The installing contractor shall be responsible to ensure that appropriate external primary entrapment safety devices be installed for the specific site conditions to protect against all

**NISQUALLY STATE PARK
NEW FULL SERVICE PARK – PHASE 2**

potential entrapment zones. Proper operation of these safety devices shall be verified and training as to the operation and maintenance of these devices for the users and owners shall be documented.

3.3 SYSTEM VALIDATION

- A. The complete system shall be adjusted to assure it is performing properly. Test gate operator through a minimum of ten full cycles and adjust to ensure operation without binding, scraping or uneven motion. Test limit switches for proper "at rest" gate position.
- B. Gate lock shall be aligned properly to lock and unlock without binding. Test gate lock through a minimum of ten full cycles and verify secure locking.
- C. All anchor bolts shall be fully concealed in the finished installation.
- D. Test and Explain Safety Features:
 - 1. Each system feature and device is a separate component of the gate system.
 - 2. Read and follow all instructions for each component.
 - 3. Ensure that all instructions for mechanical components, safety devices and the gate operator are available for everyone who will be using the gate system.
 - 4. The warning signs shipped with the gate operator must be installed in a prominent position on both sides of the gate.

3.4 OWNER TRAINING AND DOCUMENTATION

- A. Train Owner's personnel on how to safely shut of electrical power, release, and manually operate the gate. Additionally, demonstrate the general maintenance of the gate operator and accessories and provide one copy of "Programming and Operations Manual" for the Owner's use. Manuals will identify parts of the equipment for future procurement. Direct maintenance personnel to the technical support sections on HySecurity's website at www.hysecurity.com (or technical support website of approved equal manufacturer, if selected).

END OF SECTION

**NISQUALLY STATE PARK
NEW FULL SERVICE PARK – PHASE 2**

SECTION 323119 – PRIVACY FENCE

PART 1 - GENERAL

1.1 SUMMARY

A. Section Includes:

1. Scope of work. This Section includes a privacy fence at the staff residence.

1.2 RELATED WORK

A. Coordinate related work specified in other parts of the Project Specifications, including, but not limited to the following:

1. 033000 – Cast-in-Place Concrete

1.3 SUBMITTALS

A. Shop Plans: Layout of fences with dimensions, details, and finishes of components, accessories, and post foundations.

B. Product data: Manufacturer's catalog cuts indicating material compliance and specified options

1.4 REFERENCE STANDARDS

A. Reference standards cited in this specification refer to the current reference standard published at the time of the latest revision date logged at the end of this specification, unless a date is specifically cited.

B. American Society for Testing and Materials (ASTM):

1. A 123, Standard Specification for Zinc (Hot-Dip Galvanized) Coatings on Iron and Steel Products
2. A 500, Standard Specification for Cold-Formed Welded and Seamless Carbon Steel Structural Tubing in Rounds and Shapes
3. F 1043, Standard Specification for Strength and Protective Coatings on Steel Industrial Chain Link Fence Framework
4. F 1083, Standard Specification for Pipe, Steel, Hot-Dipped Zinc-Coated (Galvanized) Welded, for Fence Structures

**NISQUALLY STATE PARK
NEW FULL SERVICE PARK – PHASE 2**

1.5 QUALITY ASSURANCE

- A. Manufacturer: Company operating in the United States having U.S. manufacturing facility/facilities specializing in manufacturing chain link fence products with at least 5 years of experience.
- B. Fence contractor: Company with demonstrated successful experience installing similar projects and products in accordance with ASTM F567 and have at least 5 years of experience.
- C. Tolerances: Current published edition of ASTM specifications tolerances apply. ASTM specification tolerances supersede any conflicting tolerance.

PART 2 - PRODUCTS

2.1 WOOD TREATMENT

- A. All hem/fir wood treatment used in construction of the Privacy Fence shall be treated per Section 060573 Wood Treatment.

2.2 GENERAL

- A. Gate hinges and post caps shall be of steel, malleable iron, ductile iron or equal.
- B. Post tops may be of aluminum.
- C. All lumber used in work is nominal and refers to stock dimensional products.

2.3 PRIVACY FENCE

- A. Slats: #2 cedar free from all major decay or defects which would weaken or otherwise cause them to be unsuitable for fence slats.
- B. Bottom and Top Rail: shall be No. 1 & Better hem/fir and shall be S4S, and shall be treated with Preserve CA-C (Copper Azole) for above ground use category UC3B.

2.4 ACCESSORIES

- A. All bolts connecting hardware to timbers shall be galvanized steel hex bolts of the size noted on Drawings. All bolts shall have nuts and washers of similar grade/size as noted.
- B. Wood Screws to secure 1x6 fence slats to 2x4 top and bottom rail shall be #8 1-1/2" Phillip screw with electro zinc plated finish in a tan or similar color.

**NISQUALLY STATE PARK
NEW FULL SERVICE PARK – PHASE 2**

PART 3 - EXECUTION

3.1 EXAMINATION

- A. Verify areas to receive fencing are completed to final grades and elevations.

3.2 PREPARATION

- A. Prior to installing Footings, Contractor's Surveyor shall survey in the horizontal locations and vertical elevation the center point of each of the Round Steel Plate and footings.
- B. Contractor shall compact excavation backfills to 95% MDD.

3.3 PRIVACY FENCE FRAMING INSTALLATION

- A. Locate terminal post at each fence termination and change in horizontal or vertical direction of 30° or more.
- B. Check each post for vertical and top alignment and maintain in position during placement and finishing operations.
- C. Bottom Rail: Install bottom rails continuous, where shown on Plans. Set bottom edge of rail at 9 in. clear of finish grade.
- D. Post Spacing: Posts shall be evenly spaced in the line of fence on a maximum of 8-foot center unless otherwise noted.
- E. Concrete: Concrete for post foundations shall be Class 4500 (4500 psi) concrete mixture.
- F. Locate fence posts and install fence slats in a manner so that the clearance between the fence slats and the finish grade of the mulch is not greater than one inch (1").
- G. Take precautions to prevent any marring and gouging of wood members and fence slat surfaces during construction. Repair all damaged surfaces after completing construction.

3.4 FASTENING

- A. Washers of the size and type specified shall be used under all bolt nuts which would otherwise come in contact with wood. Check all bolts by burring the threads after the nuts have finally tightened. Vertical bolts shall have nuts on the lower end. In all cases where bolts are used to fasten timber to steel, bolt members tightly together when they are installed and retighten immediately prior to final acceptance of the work. All bolts shall have sufficient additional threading to provide at least 3/8-inch per foot thickness of timber for future retightening.
- B. Secure 1x6 fence slat to the 2x4 top and bottom rail with 2 wood screws centered on the fence slat. Screw Heads shall be on the fence slat side and equally spaced. All fence slat wood screws shall be in the same location/pattern for all fence panels.

**NISQUALLY STATE PARK
NEW FULL SERVICE PARK – PHASE 2**

3.5 NUTS AND BOLTS

- A. Bolts for footings shall be installed with the nut on the secure side of the fence.

3.6 CLEANING

- A. Clean up debris and unused or excess material and remove from the site. Completely remove all concrete, mud, and dirt from Privacy Fence.
- B. All excess concrete shall be disposed of off-site.

END OF SECTION

**NISQUALLY STATE PARK
NEW FULL SERVICE PARK – PHASE 2**

SECTION 323123 – POST AND RAIL FENCE

PART 1 - GENERAL

1.1 SUMMARY

A. Section Includes:

1. Scope of work. This Section includes post and rail (also known as buck and rail) fence at the Nisqually/Ohop Trail.

1.2 RELATED WORK

A. Coordinate related work specified in other parts of the Project Specifications, including, but not limited to the following:

1. 061000 Rough Carpentry

1.3 SUBMITTALS

A. Shop Plans: Layout of fences with dimensions, details, and finishes of components, and accessories.

B. Product data: Manufacturer's catalog cuts indicating material compliance and specified options.

1.4 REFERENCE STANDARDS

A. Reference standards cited in this specification refer to the current reference standard published at the time of the latest revision date logged at the end of this specification unless a date is specifically cited.

1. American Society for Testing and Materials (ASTM)
2. State Environmental Policy Act (SEPA)

1.5 SUBMITTALS

A. Submit under provisions of Section 01 30 00 - Administrative Requirements.

B. Product Data:

1. Manufacturer's data sheets on each product to be used.
2. Preparation instructions and recommendations.
3. Storage and handling requirements and recommendations.
4. Typical installation methods.

**NISQUALLY STATE PARK
NEW FULL SERVICE PARK – PHASE 2**

- C. Verification Samples: Two representative units of each type, size, pattern, and color.
- D. Shop Drawings: Include details of materials, construction, and finish. Include relationship with adjacent construction.

1.6 QUALITY ASSURANCE

- A. Manufacturer: Company operating in the United States having U.S. manufacturing facility/facilities specializing in manufacturing products specified in this section with a minimum of five years documented experience.
- B. Installer Qualifications: Company specializing in performing work of this section with a minimum of five years documented experience with projects of similar scope and complexity.
- C. Source Limitations: Provide each type of product from a single manufacturing source to ensure uniformity.
- D. Tolerances: Current published edition of ASTM specifications tolerances apply. ASTM specification tolerances supersede any conflicting tolerance.
- E. Mock-Up: Construct a mock-up with actual materials in sufficient time for Engineer's review and to not delay construction progress. Locate mock-up as acceptable to Engineer and provide temporary foundations and support.
 - 1. Intent of mock-up is to demonstrate quality of workmanship and visual appearance.
 - 2. If mock-up is not acceptable, rebuild mock-up until satisfactory results are achieved.
 - 3. Retain mock-up during construction as a standard for comparison with completed work.
 - 4. Do not alter or remove mock-up until work is completed or removal is authorized.
- F. DELIVERY, STORAGE, AND HANDLING
 - 1. Store and handle in strict compliance with manufacturer's written instructions and recommendations.
 - 2. Protect from damage due to weather, excessive temperature, and construction operations.
- G. PROJECT CONDITIONS
 - 1. Maintain environmental conditions (temperature, humidity, and ventilation) within limits recommended by manufacturer for optimum results. Do not install products under environmental conditions outside manufacturer's recommended limits.
- H. WARRANTY
 - 1. Manufacturer's standard limited warranty unless indicated otherwise.

**NISQUALLY STATE PARK
NEW FULL SERVICE PARK – PHASE 2**

PART 2 - PRODUCTS

2.1 MANUFACTURER

- A. Acceptable manufacturer: Parma Post & Pole, Inc. which is located at 26920 Highway 95, Parma, Idaho 83660 (1/2 mile east of Parma) Phone: 208.722.6837 Website: www.parmapostandpole.com; or approved equal.
- B. Requests for substitutions will be considered in accordance with provisions of section 016000 Product Requirements.

2.2 POST AND RAIL FENCE

- A. The posts and rails are to be untreated and unpeeled lodgepole pines, size as indicated in drawings.
- B. Posts shall be pre-cut to the specified length in the drawings, and pre-notched.

2.3 FASTENERS

- A. 60D 6” galvanized nails shall be used to nail the rails onto the fence.
- B. 70D 7” galvanized spike shall be used to nail posts for A-frames together.

PART 3 - EXECUTION

3.1 EXAMINATION

- A. Do not begin installation until substrates have been properly constructed and prepared.
- B. If substrate preparation is the responsibility of another installer, notify Engineer in writing of unsatisfactory preparation before proceeding.

3.2 PREPARATION

- A. Clean surfaces thoroughly prior to installation.
- B. Prepare surfaces using the methods recommended by the manufacturer for achieving the best results for the substrate under the project conditions.

3.3 POST AND RAIL INSTALLATION

- A. Install in accordance with manufacturer’s instructions, approved submittals, and in proper relationship with adjacent construction.

**NISQUALLY STATE PARK
NEW FULL SERVICE PARK – PHASE 2**

- B. A-Frame: A-frame shall be composed of 2 posts that are notched at the top intersection point. The posts shall be laid at a 60-degree angle one post on top of the other and lock the notches to fit snugly together. Drive a single 7” galvanized spike through the center of the intersection point.
- C. A-Frame Spacing: A-frames shall be evenly spaced in the line of fence on a maximum of 8-foot center unless otherwise noted.
- D. Posts shall be buried in 3 inches of wood chips.
- E. Rail: The top rail and bottom rail shall overhang the A-frame by 10-12 inches. Nail the rails into the posts using 60D 6” galvanized nails.
- F. Cross Rail: The cross rail shall be installed at a diagonal every 6 fence sections and shall connect one A-frame to the adjacent A-frame. Nail the cross rail with 60D 6” galvanized nails.
- G. Take precautions to prevent any marring and gouging of wood members during construction. Repair all damaged surfaces after completing construction.
- H. Post and rail fence shall not come undone by any force of manpower.

3.4 CLEANING

- A. Clean up debris and unused or excess material and remove from the site. Completely remove all concrete, mud, dirt and other substances from posts, fabric, and fittings.
- B. All excess concrete shall be disposed of off-site.
- C. Touch-up, repair or replace damaged products before Substantial Completion.

END OF SECTION

**NISQUALLY STATE PARK
NEW FULL SERVICE PARK – PHASE 2**

SECTION 323253 – LANDSCAPE BOULDERS

PART 1 - GENERAL

1.1 SCOPE OF WORK

- A. Surface and Subsurface Landscape Boulders provided by the site shall be installed as shown on plans. Contractor shall coordinate final boulder placement with Engineer.

1.2 RELATED WORK

- A. Coordinate related work specified in other parts of the Project Specifications, including, but not limited to the following:
 - 1. Section 015713 – Temporary Erosion and Sedimentation Control
 - 2. Section 311100 – Clearing and Grubbing
 - 3. Section 312000 – Earth Moving

1.3 SITE CONDITIONS

- A. Environmental Protection:
 - 1. Soil Moisture Content: Do not work when soil moisture content is so great that excessive compaction will occur, nor when it is so dry that dust will form in air or that clods will not break readily.

1.4 SUBMITTALS

- A. Contractor shall submit photographs of stockpiled Boulders. Location of stockpiled boulders to be determined by owner's representative.

PART 2 - PRODUCTS

2.1 MATERIALS

- A. Landscape Boulders:

Boulders shall be salvaged by the Contractor and stored in an Owner determined location on site until installation operations occur. Approval of Boulders used shall be at the sole discretion of Landscape Architect.

**NISQUALLY STATE PARK
NEW FULL SERVICE PARK – PHASE 2**

PART 3 - EXECUTION

3.1 EXAMINATION

A. Subgrade:

1. **Verification:** Verify that the subgrades have been graded to within one tenth of a foot (minus the topsoil depth) of the grades shown on the grading Plan.
2. **Notification of Discrepancies:** Notify the Owner in writing of any discrepancies.

3.2 SURVEY REQUIREMENTS

- A. Lines and Levels:** Establish lines and levels locate and lay out by instrumentation and similar appropriate means for all finish grades and landscape boulders.

3.3 EQUIPMENT

- A. Excavator with Hydraulic Rotating Grapple attachment shall be used to pick up and place boulders in locations as shown on plans.**

3.4 PREPARATION

A. Protection of Existing Conditions:

General: Use every possible precaution to prevent damage to existing conditions to remain such as structures, utilities, irrigation systems, plant materials and paving on or adjacent to the site of the Work.

B. Surface Preparation:

Removal: Perform all Work when necessary to remove the deleterious materials before and after subgrade preparation.

C. Rock Material Storage:

Verify Storage Area with Owner.

3.5 BOULDER PLACEMENT

- A. Contractor shall coordinate a Pre-Installation Conference with Landscape Architect prior to the placement of Boulders.**
- B. Contractor shall retain the services of a Landscape Professional skilled in Boulder Placement with the appropriate equipment, such as rotating grapple, to place and orientate each Boulder at the discretion of mutual agreement of Landscape Architect and Landscape Boulder Professional.**

**NISQUALLY STATE PARK
NEW FULL SERVICE PARK – PHASE 2**

- C. Boulders shall be buried one third of the rock's depth with the widest side down. Boulders shall be examined and oriented with the most aesthetic side towards the paved areas.
- D. Boulders shall be secured with zero movement under human power.
- E. Before completion of boulder placement, Contractor will meet with Landscape Architect onsite for final adjustments. Landscape Architect shall be the sole discretion of final Boulder placement.

3.6 CLEANUP

- A. Daily: Keep all areas of Work clean, neat, and orderly at all times.
- B. Final: Clean up and remove all deleterious materials and debris from the entire Work area prior to Final Completion.

END OF SECTION

**NISQUALLY STATE PARK
NEW FULL SERVICE PARK – PHASE 2**

SECTION 323300 – SITE FURNISHINGS

PART 1 - GENERAL

1.1 SECTION INCLUDES

- A. Bike Loop
- B. Ecology Block Enclosure
- C. ADA Bench – Owner Furnished and Contractor Installed

1.2 DESCRIPTION

- A. Furnish and install all site furnishings and miscellaneous site construction items; assemble and install with all hardware, as described in the Contract Documents. Install Owner Furnished ADA Benches.

1.3 RELATED SECTIONS

- A. Section 033000 Cast-in-Place Concrete
- B. Section 033010 Cement Concrete Paving
- C. Section 055200 Pipe Railings
- D. Section 312000 Earth Moving
- E. Section 321500 Crushed Rock Surfacing A

1.4 SUBMITTALS

- A. Product Data: Manufacturer's data sheets on each product to be used, including:
 - 1. Preparation instructions and recommendations.
 - 2. Storage and handling requirements and recommendations.
 - 3. Installation methods.
- B. Shop Drawing, Metal Fabrication and Assemblies: Indicate materials, dimensions, layout, perimeter conditions, junctions with dissimilar materials, accessories, and setting details.
- C. Provide shop drawings for all furnishings for approval prior to fabrication.
- D. Submit manufacturers' catalogue cuts and manufacturers' recommended installation instructions of items for all miscellaneous Site Furnishings.

**NISQUALLY STATE PARK
NEW FULL SERVICE PARK – PHASE 2**

- E. Verification Samples: For each finish product specified, two samples, minimum size 6 inches (150 mm) square, representing actual product, color, and patterns.
- F. Manufacturer's Certificates: Certify products meet or exceed specified requirements.
- G. Closeout Submittals: Provide manufacturer's maintenance instructions that include recommendations for periodic cleaning and maintenance of all components.

1.5 QUALITY ASSURANCE

- A. Manufacturer Qualifications: Minimum five years experience in producing site furnishings of the type specified.
- B. Installer Qualifications: All products listed in this section are to be installed by a single installer with a minimum of five years demonstrated experience in installing products of the same type and scope as specified.
- C. Single Source Responsibility:
 - 1. Obtain each type and color of stone from a single source.
 - 2. Obtain each type and color of mortar, adhesive and grout from the same source.
- D. Mock-Up: Provide a mock-up for evaluation of surface preparation techniques and application workmanship.
 - 1. Locate mock-up in location as directed by the Engineer.
 - 2. Do not proceed with remaining work until workmanship, color, and sheen are approved by Engineer.
 - 3. Mock-up area may become part of finished work.

1.6 DELIVERY, STORAGE, AND HANDLING

- A. Deliver and store products in manufacturer's unopened packaging until ready for installation.
- B. Store products under cover and in a dry location and protect from contamination, dampness, freezing or overheating.

1.7 PROTECTION

- A. Protect all work installed under this section from any cause whatsoever, including subsequent construction activities and vandalism until final acceptance.

PART 2 - PRODUCTS

2.1 MANUFACTURERS

- A. Approved Manufacturer:

**NISQUALLY STATE PARK
NEW FULL SERVICE PARK – PHASE 2**

1. CycleSafe, Inc., Address: 5211 Cascade Rd. SE, Suite 210 Grand Rapids, Michigan 49546, Phone: (616) 954-9977 Website: www.cyclesafe.com
2. Miles Sand & Gravel, Address: 400 Valley Ave. N.E. Puyallup, WA 98372, Phone: (253) 833-3705 Website: www.miles.rocks
3. Stanwood Redi-Mix, Address: 2431 Larson Rd, Stanwood, WA 98292, Phone: 360-652-7777, Website: www.stanwoodredi-mix.com

2.2 HARDWARE

- A. Wedge Anchors shall be Wedge-Bolt 410 stainless steel complying with ASTM E488 and AC 106 with a Class 4 Sealcoat as manufactured by Powers Fasteners or approved equal. Wedge Bolts diameter shall be sized as required by site furnishing manufacturers and embedment length shall be as recommended by Wedge-Bolt manufacturer. Wedge-Bolt shall have the bolt diameter and length clearly stamped on the hex head.
- B. All bolts shall be galvanized steel hex bolts with black finish of the size noted on Drawings. All bolts shall have nuts and washers of similar grade/size as noted.

2.3 BIKE LOOPS

- A. Approved Manufacturer: CycleSafe, Inc. or approved equal
- B. Model: Classic Bike U Rack, U/2 Rack
- C. Finish: Powder Coat Traffic Black, RAL 9017
- D. Mount: Surface

2.4 ECOLOGY BLOCK ENLCOSURE

- A. Approved Manufacturer: Miles Sand & Gravel or Stanwood Redi-Mix or approved equal
- B. Finish: Plain
- C. Size per plan.

2.5 ADA BENCH

- A. ADA Bench shall be Owner Furnished and Contractor installed.

PART 3 - EXECUTION

3.1 GENERAL

- A. Stake alignment and location for Owner approval prior to installation.

**NISQUALLY STATE PARK
NEW FULL SERVICE PARK – PHASE 2**

- B. Install rigid, plumb and true to lines and levels shown. Verify that all elements called for in this Section “fit” according to the drawings and existing site features.
- C. Contractor shall use carbide tipped hammer drill bits made in accordance with ANSI B212.15 to drill holes for Wedge-Bolts. Install per manufacturer’s requirements.
- D. Assemble and install all equipment specified by name/manufacture as per approved manufacture’s printed instructions/recommendations. Provide Owner with all printed instructions/recommendations.
- E. Provide painting where specified.

3.2 CAST-IN-PLACE CONCRETE FOOTINGS

- A. Construct footings for all furnishings in accordance with Section 033000 Cast- In-Place Concrete.

3.3 BIKE LOOP

- A. Assemble tight and secure and install per manufacturer’s instructions. Install Wedge Anchors per detail.
- B. Install plumb and level with zero lateral or vertical movement.
- C. Install equipment as shown on Drawings.

3.4 ECOLOGY BLOCK ENCLOSURE

- A. Ecology block enclosure shall be level and plumb with zero lateral or vertical movement. Assemble per plan.

3.5 ADA BENCH

- A. Locate and install ADA benches per Plan and Drawings and Owner’s direction.
- B. Install fasteners per Drawings.
- C. Install plumb and level with zero lateral or vertical movement.

3.6 CLEANING

- A. Clean up debris and unused material.
- B. Power wash and clean all Site Furnishings.

**NISQUALLY STATE PARK
NEW FULL SERVICE PARK – PHASE 2**

- C. Paint all scratches, marks, and minor gouges less than 1/16 in. deep/wide to match the color of the surrounding material. Any scratches, marks, and minor gouges greater than 1/16 in. deep/wide requires the replacement of the damaged furnishing.

END OF SECTION

**NISQUALLY STATE PARK
NEW FULL SERVICE PARK – PHASE 2**

SECTION 323303 – KEYPAD ISLAND

PART 1 - GENERAL

1.1 SECTION INCLUDES

- A. Provide Smart Keypad and Card Reader, Fire Box with Knox Lock Cutout, and Side-by-Side Pad Mount Pedestal for the keypad island where shown on the Plans.

1.2 RELATED WORK

- A. Coordinate related work specified in other parts of the Project Specifications, including, but not limited to the following:
 - 1. Section 033000 Cast-in-Place Concrete
 - 2. Section 055000 Metal Fabrications
 - 3. Division 26 – Electrical
 - 4. Division 27 - Telecommunications
 - 5. Section 312000 Earth Moving

1.3 REFERENCES

- A. ASTM A36 - Structural Steel.
- B. Steel Plates, Shapes, and Bars: ASTM A 36/A 36M.
- C. ASTM A123 - Zinc (Hot-Dip Galvanized) Coatings on Iron and Steel Products.
- D. ASTM A153 - Zinc Coating (Hot-Dip) on Iron and Steel Hardware.

1.4 SUBMITTALS

- A. Submit under provisions of Section 013300 – Submittal Procedures.
- B. Product Data: Manufacturer's data sheets on each product to be used, including:
 - 1. Preparation instructions and recommendations.
 - 2. Storage and handling requirements and recommendations.
 - 3. Installation methods.
- C. Shop Drawings: Indicate materials, dimensions, layout, perimeter conditions, junctions with dissimilar materials, accessories, and setting details.
- D. Verification Samples: For each finish product specified, two samples, minimum size 6 inches (150 mm) square, representing actual product, color, and patterns.

**NISQUALLY STATE PARK
NEW FULL SERVICE PARK – PHASE 2**

- E. Manufacturer's Certificates: Certify products meet or exceed specified requirements.
- F. Closeout Submittals: Provide manufacturer's maintenance instructions that include recommendations for periodic cleaning and maintenance of all components.

1.5 QUALITY ASSURANCE

- A. Manufacturer Qualifications: Minimum five years' experience in producing site furnishings of the type specified.
- B. Installer Qualifications: All products listed in this section are to be installed by a single installer with a minimum of five years' demonstrated experience in installing products of the same type and scope as specified.
- C. Single Source Responsibility:
 - 1. Obtain each type and color of stone from a single source.
 - 2. Obtain each type and color of mortar, adhesive and grout from the same source.
- D. Mock-Up: Provide a mock-up for evaluation of surface preparation techniques and application workmanship.
 - 1. Locate mock-up in location as directed by the Engineer.
 - 2. Do not proceed with remaining work until workmanship, color, and sheen are approved by Engineer.
 - 3. Mock-up area may become part of finished work.

1.6 DELIVERY, STORAGE, AND HANDLING

- A. Deliver and store products in manufacturer's unopened packaging until ready for installation.
- B. Store products under cover and in a dry location and protect from contamination, dampness, freezing or overheating.

1.7 PROTECTION

- A. Protect all work installed under this section from any cause whatsoever, including subsequent construction activities and vandalism until final acceptance.

PART 2 - PRODUCTS

2.1 MANUFACTURERS

- A. Approved Manufacturers:
 - 1. Security Brands Inc., Address: 2210 Executive Dr Garland, TX 75041, Phone: (972)474-6422, Website: www.securitybrandsinc.com; or approved equal

**NISQUALLY STATE PARK
NEW FULL SERVICE PARK – PHASE 2**

2. Goose Neck Stands (Part of the DF Supply, Inc. family), Address: DF Supply, Inc. 8500 Hadden Road Twinsburg, Ohio 44087, Phone: (888) 378-1045 Website: www.gooseneckstands.com; or approved equal

- B. Requests for substitutions will be considered in accordance with provisions of Section 016000 Product Requirements.

2.2 MATERIALS

- A. Smart Keypad and Card Reader

1. Manufacturer: Security Brands Inc.
2. Model: 27-230SK

- B. Fire Box with Knox Key Switch:

1. Manufacturer: Security Brands Inc.
2. Model: Fire Access Box with Knox Lock Cutout 15-013

- C. Side-by-Side Pad Mount Pedestal:

1. Manufacturer: Goose Neck Stands (Part of the DF Supply, Inc. family)
2. Model: 42" Ht. Black Steel Side-by-Side Mount Gooseneck Pedestal (Pad Mount) 42-TT
3. Finish: Black wrinkle powder coat for outdoor use

PART 3 - EXECUTION

3.1 KEYPAD ISLAND INSTALLATION

- A. Install at all locations shown as detailed, per manufacturer instruction, or otherwise required for rigidity, and conforming to the following additional requirements:
 1. Unless otherwise shown, the side-by-side pad mount pedestal shall be surface mounted onto the concrete island per manufacturer recommendation.
 2. Side-by side pad mount pedestal shall be set at the elevations in the Plans.
 3. Smart Keypad and Card Reader, Fire Box with Knox Key Switch, and pedestal shall be plumb and level.

3.2 CLEANUP

- A. Clean powder coated finish of bollard to be free of all concrete splatters and other surface materials.
- B. Final: Clean up and remove all debris from the entire work area prior to final completion.

END OF SECTION

**NISQUALLY STATE PARK
NEW FULL SERVICE PARK – PHASE 2**

SECTION 323913 – BOLLARDS

PART 1 - GENERAL

1.1 SCOPE OF WORK

- A. Provide Removable Bollards where shown on the Plans.

1.2 RELATED WORK

- A. Coordinate related work specified in other parts of the Project Specifications, including, but not limited to the following:
 - 1. Section 033000 Cast-in-Place Concrete
 - 2. Section 055000 Metal Fabrications
 - 3. Section 312000 Earth Moving

1.3 REFERENCES

- A. ASTM A36 - Structural Steel.
- B. Steel Plates, Shapes, and Bars: ASTM A 36/A 36M.
- C. ASTM A123 - Zinc (Hot-Dip Galvanized) Coatings on Iron and Steel Products.
- D. ASTM A153 - Zinc Coating (Hot-Dip) on Iron and Steel Hardware.

PART 2 - PRODUCTS

2.1 MATERIALS

- A. Removeable bollard shall comply with Bollard Type 1 WSDOT Standard Plan H-60.10-01
- B. Bollard finish shall be safety yellow.
- C. Reflective tape as indicated in drawings.
- D. Concrete: per Section 03 30 00 Cast -in-Place Concrete Class 3000 psi.

**NISQUALLY STATE PARK
NEW FULL SERVICE PARK – PHASE 2**

PART 3 - EXECUTION

3.1 REMOVABLE BOLLARD INSTALLATION

- A. Removable Steel Pipe Bollards: Install at all locations shown, set in concrete as detailed or otherwise required for rigidity, and conforming to the following additional requirements:
 - 1. Unless otherwise shown, the base assembly shall extend into concrete footing as detailed.
 - 2. Excavate holes for footings in firm, undisturbed or compacted soil.
 - 3. Place concrete around bollards in a continuous pour, tamp/vibrate for consolidation. Check each bollard for vertical and top alignment.
 - 4. After base plates have set, form concrete top to a ½ inch convex shape.
 - 5. Removable Bollards shall be set at the elevations in the Plans. Bollard shall be plumb.
 - 6. Finish texture of exposed concrete footing shall be a medium broom in circle direction, ninety degrees to the Fixed Bollard's center point.

3.2 CLEANUP

- A. Clean powder coated finish of Fixed Bollard free of all concrete splatters and other surface materials.
- B. Final: Clean up and remove all deleterious materials and debris from the entire work area prior to final completion.

END OF SECTION

**NISQUALLY STATE PARK
NEW FULL SERVICE PARK – PHASE 2**

SECTION 329113 – MULCH & WOOD CHIPS

PART 1 - GENERAL

1.1 RELATED DOCUMENTS

- A. Plans and general provisions of Contract, including General Conditions and Specification Sections apply to this Section.

1.2 SUMMARY

- A. Section Includes:

- 1. Scope of work. This Work includes providing Mulch and Wood Chips as shown in the Plans.

1.3 SUBMITTALS

- A. Provide one cubic foot sample of Mulch & Wood Chips.

1.4 RELATED WORK

- A. Coordinate related work specified in other parts of the Project Specifications, including, but not limited to the following:
 - 1. Section 311100 – Clearing and Grubbing
 - 2. Section 312000 – Earth Moving
 - 3. Section 329119 – Topsoil Placement & Grading

PART 2 - PRODUCT

2.1 MULCH

- A. Mulch shall be Medium Bark Mulch and shall comply with WSDOT 8-02.3(11)B.
- B. Mulch shall not contain deleterious material, and shall not contain paint, petroleum products, herbicides, fungicides, or other chemical residues that would be detrimental to animal/plant life. There shall be zero presence of deleterious material such as, not but limited to, plastic, glass, metal, or rocks.

**NISQUALLY STATE PARK
NEW FULL SERVICE PARK – PHASE 2**

2.2 WOOD CHIPS

- A. Wood Chips shall be chipped from organic material and timber cleared and grubbed from site, as indicated in Plans, and per Section 311100 – Clearing and Grubbing. Wood Chips shall be per WSDOT section 2-01.2(3). Wood Chips shall be Hog Fuel as processed by a Tub Grinder or similar on-site wood processing equipment.
- B. Owner and Contractor shall ascertain the projected volume of Wood Chips produced from project organic material and mutually agree as to the Wood Chip processing and storage location(s) and area size required.
- C. Wood Chips shall not contain deleterious material, and shall not contain paint, petroleum products, herbicides, fungicides, or other chemical residues that would be detrimental to animal/plant life. There shall be zero presence of deleterious material such as, not but limited to, plastic, glass, metal, or rocks.

PART 3 - EXECUTION

3.1 PREPARATION

- A. Contractor shall grade the landscape surfaces to receive Mulch and Wood Chips to a smooth and even grade per Plans.

3.2 MULCH AND WOOD CHIPS INSTALLATION

- A. Install Mulch and Wood Chips to depths shown on the Plans before plants have been installed. Mulch and Wood Chips depth shall be a uniform depth and shall be graded to produce a smooth landscape surface. Contractor shall tractor-walk Wood Chips into the ground. Wood Chips shall be to the depths shown on the Plans after the tractor-walk process and before plant installation.
- B. Contractor shall take precautions and measures to protect all installed plants from damage during the process of fine grading of Mulch and Wood Chips. Plants damaged by Contractor's operations shall be replaced by Contractor at no cost to Owner.

3.3 MAINTENANCE

- A. Contractor shall be responsible to weed and maintain Mulch and Wood Chips areas to be free of weeds and to assure a full design depth of Mulch and Wood Chips up to, and at the time of Final Acceptance.

END OF SECTION

**NISQUALLY STATE PARK
NEW FULL SERVICE PARK – PHASE 2**

SECTION 329119 – TOPSOIL PLACEMENT & GRADING

PART 1 - GENERAL

1.1 RELATED DOCUMENTS

- A. Drawings and general provisions of the Contract, including General Conditions and Division 1 Specification Sections, apply to this Section.

1.2 SCOPE OF WORK

- A. Installation of Topsoil Type A.
- B. Placement and Finish Grading of Topsoil Type A.

1.3 REFERENCES

- A. ASTM D 1557: Method for Laboratory Compaction Characteristics of Soil using Modified Effort

1.4 RELATED WORK

- A. Coordinate related work specified in other parts of the Project Specifications, including, but not limited to the following:
 - 1. Section 015713 – Temporary Erosion and Sedimentation Control
 - 2. Section 312000 – Earth Moving

1.5 DEFINITIONS

- A. Percent Compaction: The required in-place dry density of the material, expressed as a percentage of the maximum dry density of the same material determined by ASTM D1557-78 test procedure.
- B. Soil Subgrade: The soil surface on which topsoil is placed.
- C. Finished Grades: The final grade elevations indicated on the Grading Drawings.
- D. Aesthetic Acceptance of Grades: Acceptance by the Owner's Representative in writing of the Aesthetic Correctness of the contours as observed without a survey instrument. Aesthetic Acceptance does not address whether an area drains properly, whether the areas are at the correct elevation, or whether it has been compacted properly.
- E. Acceptance: Wherever the terms "acceptance" or "accepted" are used herein, they mean acceptance of the Owner's Representative in writing.

**NISQUALLY STATE PARK
NEW FULL SERVICE PARK – PHASE 2**

- F. Grading Drawings: Plans, sections, and profiles showing finished surface grades.
- G. Elements with Fixed Elevations: Paths, paving, concrete pads, footings, foundations, walls, and other structures with fixed-spot elevations.

1.6 SITE CONDITIONS

- A. Environmental Protection:
 - 1. Soil Moisture Content: Work soil only when within 2% of optimum moisture content.
 - 2. Do not work soil when it is so dry that dust will form in air or that clods will not break readily.
 - 3. Perform work in such a manner as to prevent overworking and over-saturation of on-site soils.
 - 4. This shall include any/all precautions necessary throughout the entire work area (including access drives/haul roads/staging areas) to control surface water, to protect soils and subgrades from heavy vehicle loads, and to achieve soil moisture levels capable of achieving specified compaction.
 - 5. No extra compensation will be paid to the Contractor due to work performed at non-optimum times or under non-optimum conditions resulting in unsatisfactory soil conditions.
 - 6. The Contractor shall correct unsatisfactory conditions at no additional cost to the Owner.

1.7 SUBMITTALS

- A. Submit product data, physical analysis, and one gallon sample of each type of topsoil.
- B. Submit soil analysis, sieve analysis, lime fertilizer and other soil amendment recommendations based on growing ornamental plants. Soil analysis shall include any recommendations for amendments, fertilizers and the like, for planting.
- C. Provide a transmittal with each sample and data that provides the project name, testing facility, date of test, contact information for testing facility, and the information listed below:

Date Submitted _____ Date Approved _____

Sub-Contractor/Supplier _____

**NISQUALLY STATE PARK
NEW FULL SERVICE PARK – PHASE 2**

PART 2 - PRODUCTS

2.1 MATERIALS

- A. Contractor shall be responsible for the supply of all natural soil and soil additives required for the performance of this Contract and for determining the volume of soil and additives required to fulfill Contract obligations.
- B. Soil shall be free of weeds, pests, toxic substances and other undesirable material harmful to turf grass or ornamental plant growth.
- C. Topsoil Type A shall be a mixture of 10% Compost and 90% Sandy loam as follows:
 - 1. Sandy Loam shall meet the following chemical and mechanical analysis:

PERMISSIBLE RANGE

- a. Salinity (millimhos per centimeter of Saturation extract @ 25°C) Nil – 3.0
 - b. Boron (saturation extract Concentration) Nil – 1.0 ppm
 - c. Sodium (sodium absorption ratio – SAR) Nil – 6.0
- 2. Planting soil shall be a biologically active, two-way mix soil consisting of 90% sandy loam and 10% recycled plant waste compost or composted dairy manure by weight thoroughly mixed together. Mixed soil shall have pH range of 5.2 to 6.5 with dolomite limestone added as necessary to attain this range.
- D. Grading Equipment: Appropriate size and flexibility to achieve the sculptural forms, profiles, straight slopes, and slope rounding indicated on the Grading Drawings.

PART 3 - EXECUTION

3.1 EXAMINATION

- A. Subgrade:
 - 1. Verification: Verify that the subgrades have been graded to within one tenth of a foot (minus the topsoil depth) of the grades shown on the grading Drawings.
 - 2. Aesthetic Acceptance: Verify that Owner's Representative has given the subgrade aesthetic acceptance. Do not place topsoil until subgrade has been accepted for aesthetic correctness.
 - 3. Notification of Discrepancies: Notify the Owner's Representative in writing of any discrepancies.

3.2 SURVEY REQUIREMENTS

- A. Lines and Levels: Establish lines and levels, locate and lay out by instrumentation and similar appropriate means for all planting area finish grades.

**NISQUALLY STATE PARK
NEW FULL SERVICE PARK – PHASE 2**

- B. General Staking: Provide a sufficient quantity of grade stakes as required to provide minimum depth layer of topsoil.

3.3 PREPARATION

- A. Protection of Existing Conditions:

- 1. General: Use every possible precaution to prevent damage to existing conditions to remain such as structures, utilities, irrigation systems, plant materials and paving on or adjacent to the site of the Work.

- B. Surface Preparation:

- 1. Inspection: Inspect subgrade soil for stones over one inch in diameter, sticks, oils, chemicals, plaster, concrete, and other deleterious materials.
- 2. Removal: Perform all Work necessary to remove the deleterious materials before and after subgrade preparation.

3.4 PREPARING SUBGRADE

- A. Prepare subgrade to avoid excessive compaction beyond what is specified in Section 312000 Earth Moving for landscape areas. If Owner's Representative determines that excessive compaction has occurred, it shall be corrected as follows:

- 1. Immediately before Topsoil Placement, scarify with a roto-tiller to a depth of 4 inches minimum in one direction.

3.5 TOPSOIL PLACEMENT

- A. Topsoil Type A

- 1. Topsoil type A shall be spread evenly in 10-inch compacted lifts to the full, compacted depth specified over the areas as shown on the Plans.
- 2. The soil shall be uniformly placed to a depth as shown in Plans.
- 3. All large clods, hard lumps and rocks 2-inches in diameter or greater and litter shall be raked up, removed and disposed of by the Contractor.

3.6 FINISH GRADING OPERATIONS

- A. General: Grade with uniform slope between points where elevations are given or between such points and existing grades, unless indicated otherwise.

- B. Soil Surface Tolerances:

- 1. Planting Areas: Bring finished soil surface to within 0.05 foot of finish grades indicated on Grading Drawings. Grade flatter areas at tighter tolerance if required to provide positive drainage.
- 2. Allowances: Make proper allowances for settlement, spoils from plant pits, etc.

**NISQUALLY STATE PARK
NEW FULL SERVICE PARK – PHASE 2**

- C. Surface Drainage:
 - 1. Slope finish grades to drain surface water away from buildings, walks, paving, and other structures unless otherwise indicated.
 - 2. Slope finish grades to drain surface water to catch basins, area drains or swales as shown on the Drawings.
- D. Depressions and Loose Material: Fill and compact depressions and remove all loose material to finish surface true to line and grade, presenting a smooth, compacted, and unyielding surface.
- E. Excessive Compaction: Rip areas that have become compacted more than 85 percent compaction to a 12-inch depth. Roto-till and blade smooth prior to planting and irrigation.

3.7 PROTECTION

- A. Erosion: Correct erosion and siltation damage at no cost to the Owner.
- B. Settlement Repair: Correct settlement within the Warranty period at no cost to the Owner.
- C. Drainage: Keep surface of topsoil in such condition that it will drain readily and effectively.
- D. Materials, Tools, and Equipment: In handling materials and operating tools and equipment, protect the topsoil from damage by laying down planks, plywood, or other accepted protective materials where required.
- E. Vehicular Traffic: Do not allow vehicles to travel in a single track. If ruts are formed, blade the topsoil smooth.
- F. Storage of Materials: Do not store or stockpile materials on topsoil.
- G. Dust Control: Use water trucks or temporary irrigation and take all precautions needed to prevent a dust nuisance to adjacent public or private properties.

3.8 CLEANUP

- A. Daily: Keep all areas of Work clean, neat, and orderly at all times.
- B. Final: Clean up and remove all deleterious materials and debris from the entire Work area prior to Final Completion.

END OF SECTION

**NISQUALLY STATE PARK
NEW FULL SERVICE PARK – PHASE 2**

SECTION 329200 – SEED MIX

PART 1 - GENERAL

1.1 SUMMARY

- A. This section includes the following:
 - 1. Soil preparation for all areas to be seeded.
 - 2. Seed Mix A
 - 3. Seed Mix B
 - 4. Seed Mix C
 - 5. Watering and Maintenance

1.2 RELATED SECTIONS

- A. Section 311100 – Clearing and Grubbing
- B. Section 312000 – Earth Moving
- C. Section 329119 – Topsoil Placement & Grading

1.3 REFERENCES

- A. AAN: American Association of Nurserymen
- B. ANSI: American National Standards Institute
 - 1. American Standard for Nursery Stock, ANSI Z60.
- C. All standards shall include the latest additions and amendments as of the date of advertisement for bids.

1.4 SUBMITTALS

- A. Seeding Schedule indicating dates anticipated for seed application.
- B. Data for approval before seeding commences:
 - 1. Cut sheet(s) indicating mix name, description, confirmation that seed mixes matches the areas and site conditions specified, and that the seed varieties are formulated for Pacific Northwest applications.
 - 2. Complete analysis of each seed mix, include seed varieties description, percent of pure seed, germination, other crop seed, inert and weeds, and the germination test data. All crop seed in excess of one (1) percent must be itemized.

**NISQUALLY STATE PARK
NEW FULL SERVICE PARK – PHASE 2**

3. Commercial Fertilizer product information, including product label, fertilizer analysis, release rate, release mechanism, etc.
4. Technical data for the hydromulch and tackifier.

C. Data for Approval After Seed Mixes are Delivered

1. Actual product labels from two (2) of the seed mix bags delivered to the site.
2. Confirmation that Owner's Representative has inspected all seed mixes, fertilizer, hydromulch, and tackifier containers, and confirmed that each item matches the products specified.

1.5 QUALITY ASSURANCE

- A. Manufacturer: Company operating in the United States having U.S. manufacturing facility/facilities specializing in manufacturing products specified in this section with a minimum of five years documented experience.
- B. Installer Qualifications: shall be licensed in the State of Washington, shall have a minimum of 5 years demonstrated, successful, experience on projects similar in scope and materials.
- C. Source Limitations: Provide each type of product from a single manufacturing source to ensure uniformity.

1.6 DELIVERY, STORAGE, AND HANDLING

- A. Store and handle in strict compliance with manufacturer's written instructions and recommendations.
- B. Protect from damage due to weather, excessive temperature, and construction operations.

1.7 PROJECT CONDITIONS

- A. Maintain environmental conditions (temperature, humidity, and ventilation) within limits recommended by manufacturer for optimum results. Do not install products under environmental conditions outside manufacturer's recommended limits.

1.8 WARRANTY

- A. Manufacturer's standard limited warranty unless indicated otherwise.

PART 2 - PRODUCTS

2.1 MANUFACTURER

- A. Acceptable manufacturer: Acceptable manufacturer: Sunmark Seeds, Address: 12775 NE Marx St., Building 14 Portland, OR 97230, Phone: 503.241.7333, Website: www.sunmarkseeds.com

**NISQUALLY STATE PARK
NEW FULL SERVICE PARK – PHASE 2**

- B. Requests for substitutions will be considered in accordance with provisions of section 016000 Product Requirements.

2.2 GENERAL

- A. Seed Mix shall be the mix indicated on the Plans, and shall meet or exceed the following:
1. Seeds shall be 98% pure with a minimum of 90% germination.
 2. Total weed seed shall not exceed 0.5%.
 3. Maximum percent inert and other crop shall be 1.50% of total seed mix
 4. Seeds shall conform to the requirements of RCW Chapter 15.49, Washington State Seed Law, and where applicable, the Federal Seed Act.
 5. All seeds shall be free of weed seed listed as primary noxious by RCW 15.49. Seeds shall not contain weed seeds listed as secondary noxious by RCW 15.49, single or collective in excess of the labeling tolerance specified by RCW 15.49
 6. Rejection. When seeds furnished under this specification fail to meet the requirements within tolerance, as provided by RCW 15.49, the lot shall be rejected or subjected to fiscal adjustment.
 7. Preparation for Delivery. Seeds shall be packed in clean, sound containers of uniform weight, and labeled as required by RCW 15.49

2.3 SEED MIX A

- A. Seed Mix A shall be equal to Sunmark Seeds Turf Shadow Mixture and shall be comprised of the following:

Botanical Name	Common Name	% By Weight	Seeds per lb. of Mix	Seeds per lb.	Actual % by Seed Size
Lolium perenne var Cutter II*	Cutter II Perennial Ryegrass	20.00%	56000	280000	14.81%
Lolium perenne var Dasher 3*	Dasher 3 Perennial Ryegrass	20.00%	56000	280000	14.81%
Festuca rubra var Garnet*	Garnet Creeping Red Fescue	20.00%	86000	430000	22.75%
Festuca rubra spp. fallax var Windward*	Windward Chewings Fescue	20.00%	90000	450000	23.81%
Festuca brevipila var Spartan II*	Spartan II Hard Fescue	20.00%	90000	450000	23.81%
	Totals:	100.00%	378000		100.00%

*Varieties may change at time of blending

**NISQUALLY STATE PARK
NEW FULL SERVICE PARK – PHASE 2**

2.4 SEED MIX B

A. Seed Mix B shall be two separate applications of two different seed mixes as follows:

1. First application, broadcast seed the area with the following wildflower seed mixture:

Botanical Name	Common Name	% By Weight
<i>Achillea millefolium</i>	Yarrow	33.33%
<i>Anaphalis margaritacea</i>	Pearly everlasting	33.33%
<i>Solidago canadensis</i>	Canada goldenrod	33.33%
	Totals:	100.00%

2. Second application, hydroseed the indicated area in the plans, with the following equivalent of Sunmark Seeds Turf Shadow Mixture:

*Varieties may change at time of blending

2.5 SEED MIX C

A. Seed Mix C shall be a 50/50 Blend of the following equivalent of Sunmark Seeds Woodlands Mix and Native Uplands seed mix:

1. Woodland Mix shall be a native tree and shrub mix comprised of the following:

Botanical Name	Common Name	% By Weight	Seeds per lb. of Mix	Seeds per lb.	Actual % by Seed Size
<i>Rosa nutkana</i>	Nootka Rose	25.00%	11250	45,000	
<i>Symphoricarpos alba</i>	Common Snowberry	20.00%	15200	76,000	
<i>Cornus sericea</i>	Redosier Dogwood	18.00%	31140	173,000	
<i>Amelanchier alnifolia</i>	Saskatoon Serviceberry	14.75%	5679	38,500	
<i>Mahonia repens</i>	Creeping Barberry	10.00%	5400	54,000	
<i>Sambucus racemosa</i>	Red Elderberry	9.00%	19440	216,000	
<i>Alnus rubra</i>	Red Alder	3.00%	20010	667,000	
<i>Holiduscus discolor</i>	Oceanspray	0.25%	17000	6,800,000	
	Totals:	100.00%	125119		100.00%

*Varieties may change at time of blending

**NISQUALLY STATE PARK
NEW FULL SERVICE PARK – PHASE 2**

2. Native Uplands Mix shall be a seed combination of the following drought-tolerant native grasses:

Botanical Name	Common Name	% By Weight	Seeds per lb. of Mix	Seeds per lb.	Actual % by Seed Size
<i>Elymus glaucus</i>	Blue Wildrye	50.00%	55000	110000	9.24%
<i>Festuca rubra rubra</i>	Native Red Fescue	30.00%	150000	500000	25.21%
<i>Bromus carinatus</i>	California Brome	10.00%	10000	100000	1.68%
<i>Agrostis exarata</i>	Spike Bentgrass	10.00%	380000	3800000	63.87%
	Totals:	100.00%	595000		100.00%

*Varieties may change at time of blending

2.6 HYDROSEEDING EQUIPMENT

- A. A commercially produced hydroseeder with mechanical agitation shall be used, with the following characteristics:
1. Mechanical hydroseeder that utilizes water as a carrying agent, and a continuous, paddle-blade agitation system, capable of operating in two directions to ensure homogenous mixing of the specified materials, and equipped with distribution and discharge spray nozzles that will provide a uniform distribution of the slurry.
 2. Homemade equipment or equipment with agitation by recirculation only shall not be permitted.
 3. Hydroseeding equipment shall meet all federal, state, and local codes for backflow prevention during loading operation.

2.7 HYDROSEEDING MIX MATERIALS

- A. Hydromulch shall be SILVA MULCH at forty-five (45) pounds per 1,000 square feet, or approved equal.
- B. Binder shall be J-TAC at two (2) pounds per 1,000 square feet, or approved equal.

2.8 FERTILIZER

- A. Commercial Fertilizer seed areas before and after planting shall be a commercially available, general purpose, 10-20-20 fertilizer for initial applications, and shall include the following analysis:

Total Nitrogen (N)	10%
4.6% Ammoniacal Nitrogen	
3.2% Urea Nitrogen	
3.3% Coated Slow Release Urea Nitrogen	
2.3% Slowly Available Water Soluble Nitrogen*	
1.6% Water Insoluble Nitrogen	

**NISQUALLY STATE PARK
NEW FULL SERVICE PARK – PHASE 2**

Available Phosphoric Acid (P ₂ O ₅) Slow Release	20%
Soluble Potash (K ₂ O) Slow Release	20%
Sulfur (S)	4%
Boron (B)	0.06%
Copper (Cu)	0.06%
Iron (Fe)	1%
Manganese (Mn)	0.15%
Zinc (Zn)	0.14%

Derived from Urea, Sulfur-Coated Urea, Methylene Ureas, Ammonium Phosphate, Sulfate of Potash, Muriate of Potash, Iron Sulfate, Calcium and Sodium Borate, Copper Oxide and Sulfate, Iron Oxide Sulfate and Frit, Manganese Oxide and Sulfate, Zinc Oxide and Sulfate.

* Slowly Available Water-Soluble Nitrogen from Methylene Ureas.

- B. Fertilizer shall be standard free flowing. Fertilizer shall be packaged in new, waterproof, non-overlaid bags clearly labeled as to weight, manufacturer and content.
- C. Application rate of nitrogen: 1 lb Actual N₂/1000 square feet

PART 3 - EXECUTION

3.1 TIMING

- A. Unless otherwise approved by the Owner's Representative, seeding shall conform to WSDOTSS Section 8-01.3(2)F, Dates for Application of Final Seed, Fertilizer, and Mulch.
- B. If seeding application and establishment is not achieved due to the onset of the dormant season for growth, approval will be issued in April of the following spring, or at a date mutually agreed upon by the Owner and Contractor, once active seed growth has restarted, and an acceptable stand of turfgrass can be achieved.
- C. The Contractor shall only be held to the 30 day maintenance period, during periods of active turfgrass growth. Maintenance is not required during dormant periods for turfgrass.

3.2 EXAMINATION

- A. Examine areas to receive seed mix for compliance with requirements and other conditions affecting performance.
- B. Verify finish grade is correct before beginning work.
- C. Proceed with installation only after unsatisfactory conditions have been corrected.

3.3 PREPARATION

**NISQUALLY STATE PARK
NEW FULL SERVICE PARK – PHASE 2**

- A. Protect structures, utilities, sidewalks, pavements, and other facilities, trees, shrubs, and plantings from damage caused by seeding operations.
 - B. Loosen grade to a minimum depth of 2 inches. Remove stones larger than 2 inches in any dimension and sticks, roots, rubbish, and other extraneous matter and legally dispose of them offsite.
 - C. Finish Grading:
 - 1. Finish grade is defined as the top surface of areas to receive seed prior to the installation, unless otherwise noted on the Drawings.
 - 2. Grade, roll, rake to remove ridges and fill depressions, and meet finish grades.
 - 3. Remove surface debris and rocks larger than one (1) inch in diameter. Any portion of a partially buried rock that measures greater than or equal to 1" diameter which is visible at the surface must be removed.
 - 4. Do not disturb or interfere with surface drainage and/or drainage swales.
 - 5. Finish grade within a tolerance of plus or minus 0.05 foot in ten (10) linear feet.
 - 6. Use a cultipacker for final rolling of the prepared compacted bed prior to installing seed, to create a smooth, uniform plane, with loose, uniformly fine texture.
 - D. Restore areas if eroded or otherwise disturbed after finish grading and before planting.
 - E. Obtain Owner's Representative inspection and approval of finish grade prior to installation.
- 3.4 HYDROSEEDING EQUIPMENT FOR SEED MIX A, B, AND C APPLICATION
- A. A commercially produced hydroseeder with mechanical agitation shall be used, with the following characteristics:
 - 1. Mechanical hydroseeder that utilizes water as a carrying agent, and a continuous, paddle-blade agitation system, capable of operating in two directions to insure homogenous mixing of the specified materials, and equipped with distribution and discharge spray nozzles that will provide a uniform distribution of the slurry.
 - 2. Homemade equipment or equipment with agitation by recirculation only shall not be permitted.
 - 3. Hydroseeding equipment shall meet all federal, state, and local codes for backflow prevention during loading operation.
 - 4. Seed Mix B shall only hydroseed the second application of seed of the Turf Shadow Mix.
- 3.5 HAND SEED BED PREPARATION AND APPLICATION EQUIPMENT
- A. Seed Mix B shall only be hand seeded in the first application of the wildflower seed mix, see section 2.4.A.1
 - B. Hand seed to provide even and uniform coverage. Hand seed half of the seeds while walking in one direction (e.g. north to south), and the other half in a perpendicular direction (e.g. east to west).
 - C. Contractor may use manual bed preparation and seeding equipment for seed application, with approval from the Owner's Representative, only in areas where seeding using the specified

**NISQUALLY STATE PARK
NEW FULL SERVICE PARK – PHASE 2**

equipment is impractical, as a result of available space, or the potential to damage existing or constructed improvements,

- D. Water-filled, hand pulled rollers shall be used to roll and smooth the seed beds.

3.6 INSTALLATION

A. Seed Mix A Establishment

1. Keep the seed bed uniformly moist until germination is evident (seedlings break the seedbed surface) by using a water truck as many times a day required to maintain constant moisture on the seedlings without drying out.
2. Apply a second half-rate application of fertilizer ten working days after seed application is completed.
3. Once all seedlings have reached approximately ½ inch above the seedbed, reduce watering frequency as necessary to maintain uniform moisture for healthy seed growth, but not dry out the seed bed.
4. Commence mowing as soon as the grass has reached a height of 2-1/2 inches.
5. Prior to the first mowing, apply a second, half-rate of fertilizer over the seed bed.
6. Grow and maintain, including, but not limited to, watering, mowing, and clean-up, until the seeded area has filled in to an acceptable condition.
7. Acceptable condition shall mean a full stand of grass, mowed to a uniform 1-1/2 inch height, and free of bare spots, weeds, and/or other undesirable plant species, as approved by the Owner.
8. Mow with a sharp, rotary blade to reduce grass height to 1-1/2 inches.
9. Maintain the grass at a uniform height of 1-1/2 inches by mowing once weekly until Substantial Completion is awarded.
10. Operate the irrigation system to provide adequate moisture required for active grow-in, at least one (1) inch of water per week divided into waterings every other day..
11. Request the Owner inspect the seed area to determine substantial completion, and if approved, immediately commence the 30 day Maintenance Period.
12. Substantial Completion shall be established if the seeded area is clean and free from trash and debris, grass is full green, vigorously growing, has been mowed to a uniform 1-1/2 in. height with a clean, sharp, blade; all clippings are picked up and removed, and the condition of the turfgrass meets the requirements established herein.
13. If the Owner finds any seed area unacceptable, the Contractor shall immediately repair the areas at Contractor's expense until the Owner determines acceptance.

B. Seed Mix B Establishment

1. Two different seed mixes will be applied to the area indicated in the Plans. The first application of wildflower seed mix shall be hand seeded to provide even and uniform coverage in an application rate of 4-8 ounces per 1,000 square feet. Hand seed half of the seeds while walking in one direction (e.g. north to south), and the other half in a perpendicular direction (e.g. east to west). Rake the area that was seeded then gently compact using a roller or similar device. The second application of seed mix shall be the Turf Shadow Mix and shall be hydroseeded immediately after application of the first seed mix.

**NISQUALLY STATE PARK
NEW FULL SERVICE PARK – PHASE 2**

2. Keep the seed bed uniformly moist until germination is evident (seedlings break the seedbed surface) by using a water truck as many times a day required to maintain constant moisture on the seedlings without drying out.
3. Apply a second half-rate application of fertilizer ten working days after seed application is completed.
4. Once all seedlings have reached approximately ½ inch above the seedbed, reduce watering frequency as necessary to maintain uniform moisture for healthy seed growth, but not dry out the seed bed.
5. Grow and maintain, including, but not limited to, watering, and clean-up of the seeded area until it has filled into an acceptable condition.
6. Acceptable condition shall mean a full stand of grass free of bare spots, weeds, and/or other undesirable plant species, as approved by the Owner.
7. Hand water to provide adequate moisture required for active grow-in, at least one (1) inch of water per week divided into waterings every other day.
8. Request the Owner inspect the seeded area to determine substantial completion, and if approved, immediately commence the 30 day Maintenance Period.
9. Substantial Completion shall be established if the seeded area is clean and free from trash and debris, grass is full green and vigorously growing; and the condition of the turfgrass meets the requirements established herein.
10. If the Owner finds any seed area unacceptable, the Contractor shall immediately repair the areas at Contractor's expense until the Owner determines acceptance.

C. Seed Mix C Establishment

1. Keep the seed bed uniformly moist until germination is evident (seedlings break the seedbed surface) by using a water truck as many times a day required to maintain constant moisture on the seedlings without drying out.
2. Apply a second half-rate application of fertilizer ten working days after seed application is completed.
3. Once all seedlings have reached approximately ½ inch above the seedbed, reduce watering frequency as necessary to maintain uniform moisture for healthy seed growth, but not dry out the seed bed.
4. Grow and maintain, including, but not limited to, watering, and clean-up of the seeded area until it has filled into an acceptable condition.
5. Acceptable condition shall mean a full stand of grass free of bare spots, weeds, and/or other undesirable plant species, as approved by the Owner.
6. Hand water to provide adequate moisture required for active grow-in, at least one (1) inch of water per week divided into waterings every other day.
7. Request the Owner inspect the seeded area to determine substantial completion, and if approved, immediately commence the 30 day Maintenance Period.
8. Substantial Completion shall be established if the seeded area is clean and free from trash and debris, grass is full green and vigorously growing; and the condition of the turfgrass meets the requirements established herein.
9. If the Owner finds any seed area unacceptable, the Contractor shall immediately repair the areas at Contractor's expense until the Owner determines acceptance.

3.7 30 DAY MAINTENANCE PERIOD

- A. The 30-day Maintenance and Establishment Period will begin on the date Substantial Completion is issued by the Owner's Representative.

**NISQUALLY STATE PARK
NEW FULL SERVICE PARK – PHASE 2**

- B. It is expressly understood that the Contractor will be responsible during the 30 maintenance and establishment period for normal landscape maintenance of the seeded areas.
- C. Maintenance shall include, but not be limited to, watering, mowing, weeding, monitoring and treating any disease and/or pest-problems, and any other maintenance requirements (per standard trade practices) to keep the areas in a normal healthy growing condition.
- D. Replace all seed areas if plants are dead, or dying to the point they are no longer in a satisfactory growing condition, as determined by the Owner for the duration of the period.
- E. Make replacements within seven (7) working days of notification from the Owner. Remove dead seed areas within two (2) working days of notification and mark planting plan showing the exact location of replaced areas.
- F. The fertilization, watering, and maintenance requirements specified in this Section are the minimum requirements. Provide additional fertilizer applications, waterings, mowings, and maintenance methods necessary, beyond the minimum requirements specified, to provide an acceptable stand of seed at Contractor's cost.
- G. Required Tasks During the 30 Day Maintenance Period
 - 1. Tasks shall include, but not be limited to mowing of Seed Mix A (three mowings minimum required, and as many additional mowings as it takes to maintain turf to a 1-1/2 inch height without removing more than 1/3 blade height at any one mowing), edging, weed control, and watering.
- H. Owner's Recourse to Lack of, or Inadequate/Improper Maintenance
 - 1. It is agreed that the Owner will suffer damage and be put to additional expense in the event that the Contractor does not perform maintenance duties as specified above, and as it may be difficult to accurately compute the amount of such damage, the Contractor hereby expressly covenants and agrees to the following maintenance performance measures:
 - a. Weeding: The Owner will issue the Contractor up to two written notices during the maintenance period to weed contract planting areas. Whereupon the Contractor shall have seven calendar days, per notice, to complete the weeding. If weeding is not performed after the second notice, the Owner shall terminate the contract with the Contractor and contact the Contractor's Bonding Company to perform the work for the rest of the maintenance period.
 - b. Replacing Dead or Dying Seed: The Owner will issue the Contractor up to two written notices during the maintenance period to replace dead or dying seed. Whereupon the Contractor shall have seven calendar days, per notice, to replace the dead or dying seeded areas. If replacement is not performed after the second notice, the Owner shall terminate the contract with the Contractor and contact the Contractor's Bonding Company to perform the work for the rest of the maintenance period.
 - c. Regular watering: The Owner will issue the Contractor up to two written notices during the maintenance period to water the contract plants. Whereupon the Contractor shall have seven (7) calendar days, per notice, to water contract turfgrass. If plant irrigation is not performed after the second notice, the Owner

**NISQUALLY STATE PARK
NEW FULL SERVICE PARK – PHASE 2**

shall terminate the contract with the Contractor and contact the Contractor's Bonding Company to perform the work for the rest of the maintenance period.

3.8 ACCEPTANCE OF ESTABLISHED AREAS

- A. After completion of all seed mix installation and the 30 day maintenance period, the Owner will review all areas for compliance.
- B. Areas with an acceptable, uniform stand of turfgrass, meadow and shrub mix, as determined by the Owner's Representative, shall be considered acceptable.
- C. Once the date of acceptance has been agreed upon between the Owner and Contractor, the Owner shall immediately take over the maintenance of all accepted areas.
- D. Seeded areas without an acceptable, uniform stand, or areas damaged through any other cause prior to this inspection shall be re-seeded using the material specified for that area as herein specified at the Contractor's expense, and regrown, including specified maintenance, until an acceptable stand is achieved.

3.9 CLEAN-UP

- A. Regular policing of the project site of trash and project debris will be required.
- B. The disposal to all trash will be the Contractors' responsibility.
- C. Repair and replace broken or defective pavement, fencing, utilities, and all existing or constructed improvements damaged by the work of this section, as directed by the Owner's Representative.
- D. Clean and remove tire tracks on all pavement, related to the work of this Section.
- E. Clean and remove all material stockpiles and waste materials, dispose legally off site, and restore pavements, natural turf areas, and planting beds.
- F. Sweep concrete pavement and wash free of stains, discoloration, dirt, infill materials, and other foreign material just prior to final inspection.
- G. Remove surplus planting materials and rubbish from planting beds, rake beds neatly to an even, fine grade around all plants and wash clean all paved areas.
- H. Leave project clean, and free from all plating operation debris.

END OF SECTION

**NISQUALLY STATE PARK
NEW FULL SERVICE PARK – PHASE 2**

SECTION 329300 - PLANTS

PART 1 - GENERAL

1.1 DESCRIPTION

- A. The work included in this Specification (whether mentioned or not) shall include, but not be limited to providing all plants, trees, groundcovers, and seed mix A,B, & C specified on the Drawings, all equipment, labor, excavation, backfill, fertilizers, soil amendments, staking, protection, waste disposal, restoration, tools, materials, tests, permits, and other related items necessary for the complete installation and maintenance tasks specified herein, of all plant-materials described in the Drawings, in a first quality, workmanlike manner.

1.2 RELATED SECTIONS

- A. Section 311100 – Clearing and Grubbing
- B. Section 312000 – Earth Moving
- C. Section 329113 – Mulch & Wood Chips
- D. Section 329119 – Topsoil Placement & Grading
- E. Section 329300 – Seed Mix

1.3 REFERENCES

- A. AAN: American Association of Nurserymen
- B. ANSI: American National Standards Institute
 - 1. American Standard for Nursery Stock, ANSI Z60.
- C. All standards shall include the latest additions and amendments as of the date of advertisement for bids.

1.4 SUBMITTALS

- A. Plant Documentation:
 - 1. Within 30 days after award of Contract, submit documentation that all specified plant materials have been ordered. Should the Contractor neglect to provide this documentation within the allocated time, Contractor may forfeit any substitution benefits.
 - 2. List respective growing or storage locations with addresses.
 - 3. List suppliers' names, addresses, and phone number.

**NISQUALLY STATE PARK
NEW FULL SERVICE PARK – PHASE 2**

1.5 QUALITY ASSURANCE

- A. The Contractor shall provide one person who:
 - 1. Directs work performed under this section.
 - 2. Is familiar with the materials and best methods for installation.
 - 3. Is present at all times during execution of work in this section.

- B. Installer Qualifications: The Landscape Contractor shall hold a currently active, license in the State of Washington, shall have a minimum of 5 years' experience, and shall have completed landscaping work similar in material, design, and extent to that indicated for this Project, and with a record of successful landscape establishment.

- C. Contractor must be familiar and comply with American Standard for Nursery Stock published by the American Association of Nurserymen.

- D. The Contractor shall continuously maintain a competent superintendent or foreman during the progress of the work, with the authority to act for the Contractor in all matters pertaining to the work. The Contractor shall give personal attention to the fulfillment of the Contract and shall keep the work under control. Subcontractors shall not be recognized, and all persons engaged in the work will be considered employees of the Contractor and their work shall be subject to the provisions of the Contract and Specifications.

- E. The Contractor shall confine operations to the working areas allotted by the Owner for operations, including material and equipment storage.

- F. The Contractor shall progressively clean the work site of debris and rubbish as the work proceeds.

- G. Plant Material:
 - 1. Provide quality, size, genus, species, and variety of trees and shrubs indicated, complying with applicable requirements of the current edition of ANSI Z 60.1 "American Standard for Nursery Stock."
 - 2. All plants shall be shipped with certificates of inspection, as required by law.
 - 3. Each tree and shrub shall bear a securely attached waterproof tag bearing legible designation of botanical and common name.
 - 4. Plant names shall conform to the latest edition of Standard Plant Names as adopted by the American Joint Committee of Horticulture Nomenclature.

- H. Measurements: Measure trees and shrubs according to the current edition of ANSI Z 60.1 with branches and trunks or canes in their normal position. Do not prune to obtain required sizes.

- I. Field quality control and inspections:
 - 1. All plant material shall be inspected by the Owner's Representative prior to planting.
 - 2. Notify the Owner of delivery schedule 24 hours in advance to allow inspection upon arrival at the work area.
 - 3. Rejected plant materials shall be set apart from approved materials, and removed from the project site by the end of the day of rejection.

**NISQUALLY STATE PARK
NEW FULL SERVICE PARK – PHASE 2**

1.6 DELIVERY

- A. Bare root and balled and burlapped plants shall conform to ANSI Z60.1.
- B. Notify the Owner of delivery schedule 24 hours in advance to allow inspection upon arrival at the work area.
- C. Remove unacceptable plant material from the work area immediately.
- D. Do not deliver more plant materials than can be planted in one week.
- E. Protect plants during delivery to prevent damage to root ball or desiccation of leaves.

1.7 STORAGE

- A. Heel in bare-root or balled and burlapped plants immediately upon delivery if not planted within 4 hours.
- B. Store plants in shade and protect from harmful weather until planted.
- C. Water, maintain, and protect stored material from drying or other injury or damage.
- D. Store plants in upright position and allow sufficient ventilation.

1.8 HANDLING

- A. Do not pick up containerized or balled plants by stems or trunks.
- B. Do not drop plants.

1.9 SITE CONDITIONS

- A. Plant after preparation of plant beds and when soil conditions are suitable in accord with locally accepted practice.
- B. Planting Conditions: Planting is not permitted under the following conditions, unless otherwise approved:
 - 1. Cold Weather: Less than 32°F.
 - 2. Hot Weather: Greater than 90°F.
 - 3. Wet Weather: Saturated soil.
 - 4. Windy Weather: Wind velocity greater than 20 mph.

1.10 WARRANTY PERIOD

- A. The Contractor will not be held responsible for vandalism, theft, atypical weather conditions or hidden peculiarities of work area during the warranty period.
- B. Plant materials shall be in healthy condition at end of the warranty period.

**NISQUALLY STATE PARK
NEW FULL SERVICE PARK – PHASE 2**

- C. Remove dead and rejected material within five days of being so directed. Replace as soon as possible.
- D. Repair, at no additional cost to the Port, any damage to other plants or other property caused by the Contractor during replacement of plant materials during the warranty period.

PART 2 - PRODUCTS

2.1 WATER

- A. Provide all arrangements necessary to ensure an adequate supply of water to maintain all plants in this Contract.
- B. Furnish necessary hose, equipment, attachments, pumps, watering trucks, and/or accessories for the adequate irrigation of planted areas, as may be required to complete the work specified.

2.2 PLANTS

A. Quantities and Species/Varieties

- 1. Compliance with Types and Quantities: The Contractor shall plant the specified plant species, varieties, and quantities as shown on the Plans, the plant list and as described herein.
- 2. A list of specified plants, quantities, condition, and sizes can be found on the plans.
- 3. Substitutions: No substitutions shall be made without written approval by the Owner. Requests for substitutions must be accompanied by written proof, on supplier letterhead from no less than five sources, I.E. major sources that supply the specified plant material, that any plant is not available.
- 4. Plants shall be from stock well acclimated to prevailing conditions at the project site, and which have been consistently cultivated in these conditions.
- 5. Cold storage plants shall be rejected.
- 6. Plants shall be First Quality, fresh, well foliated, in prime condition when in leaf, exhibiting normal habit of growth, having all buds intact, and viable.
- 7. Plants shall be free from disease, injury, insects, insect eggs, root and other types of weevils, larva, all seeds, weed roots, and defects such as knots, sun scald, injuries, abrasions, disfigurement and irregular growth arising from frost damage.
- 8. Encircling Roots:
 - a. Do not deliver any plants with encircling roots to the job site.
 - b. Plants with roots encircling the root mass more than once shall be rejected.

B. General Plants Requirements

- 1. Do not prune or top the plant before delivery.
- 2. Protect bark, branches, and root systems from sun scald, drying, sweating, whipping, and other handling and tying damage.
- 3. Do not bend or bind-tie trees or shrubs in such a manner as to destroy natural shape.
- 4. Provide protective covering during delivery.
- 5. Dry and/or broken root balls and/ or damaged containers shall be rejected.

**NISQUALLY STATE PARK
NEW FULL SERVICE PARK – PHASE 2**

6. Do not drop trees and shrubs, or transport them by the trunk without supporting the rootball, during delivery.

C. Container Grown Plants:

1. Shall have been grown in their containers for at least one full year to develop a root ball incapable of falling apart, once it is removed from the container.
2. Shall not be root bound in the container to the point that the root mass encircles the root ball, or to the point the container must be cut off for removal.
3. Shrubs with root balls incapable of holding together after removal from the container, or with excessive root masses enveloping the rootball shall be rejected by the Owner's Representative.
4. Root Crowns: Root crowns shall be above ground level. Plants delivered to the site with root crowns buried in root ball or nursery ground level shall be inspected by the Owner to determine if removing the soil above the root crown is sufficient a measure to gain acceptance of the plant. If removing soil from the top of the root ball to expose the top of the root crown is insufficient measure to gain acceptance, then the Contractor shall remove the plant from the site and replace it with another acceptable plant.

- D. Plugs: Plugs shall be in deep, open bottomed, 10 cubic inch containers. No species shall be substituted without approval of the Landscape Architect.

E. Field Grown Plants:

1. Deliver freshly dug ball and burlap stock with firm, natural balls of earth of sufficient diameter to encompass fibrous and feeding root systems, necessary for the full recovery of the plant, in accordance with American Standard for Nursery Stock.
2. Root ends shall have been cleanly cut flush with the sides of the root ball.
3. Rootballs shall be firm, unyielding, and do not fall apart when the wrapping is removed for planting.
4. Shall not be root bound to the point that the root mass encircles the root ball, or to the point roots must be pruned before planting.
5. Shrubs with root balls incapable of holding together after the burlap is removed for planting, or with excessive root masses enveloping the rootball shall be rejected by the Owner's Representative.
6. Handle ball and burlap stock by the root ball, never by the main stem.
7. Trees found to be handled by the main stem shall be rejected by the Owner.

2.3 MULCH AND WOOD CHIPS

- A. Refer to Section 329113 – Mulch and Wood Chips.

PART 3 - EXECUTION

3.1 GENERAL

- A. All areas shall be finish graded and approved by the Owner before planting of plants.

**NISQUALLY STATE PARK
NEW FULL SERVICE PARK – PHASE 2**

- B. Finished grades and elevations in all areas shall allow for planting soil and mulch added to individual planting areas as specified herein.
- C. All grades shall flow smoothly into one another and produce positive drainage.
- D. Mitigate adverse drainage conditions that may affect plant growth.
- E. Deliver trees, shrubs, ground covers, and plants after preparations for planting have been completed and install immediately.
- F. If planting is delayed more than 6 hours after delivery, set planting materials in a nursery area as approved by the Owner.
- G. Protect stockpiled materials from weather and mechanical damage.
- H. Set balled stock on ground and heel-in in the holding area. Heeling-in includes covering root ball with topsoil mix, mulch, or compost.
- I. Maintain plants in a moist condition in the heeling mix.
- J. Do not remove container-grown stock from containers before time of planting.
- K. Water as often as necessary with a fine-mist spray to maintain root systems in a moist condition.

3.2 STAKING AND LAYOUT

- A. Stake all tree locations in the field with flagging, with the tree name written boldly and clearly in ink, for the Owner's Representative to verify against the Drawings.
- B. Draw the outlines of all shrub beds with marking paint, for Owner's Representative to verify against the Drawings.
- C. Make minor adjustments as marked in the field by the Owner's Representative.

3.3 PLANT INSTALLATION

- A. Planting Trees & Shrubs
 1. Transport carefully to prevent damage. Tie branches as necessary. Use burlap bags to protect bark from rope chafing. Do not drag plant material, or pull or carry plant materials by the crown, foliage, or trunk.
 2. Dig pits for plants as indicated on Plans, and consistent with good horticultural practice.
 3. The inside surfaces of all planting pits are to be rough, not smooth.
 4. Backfill material for plantings is to be Topsoil Type A and Common Borrow A per the Drawings.
 5. If the Contractor encounters clay soil or any unusual condition which may be detrimental to the new planting, the Contractor shall notify the Owner immediately.
 6. The Contractor will ensure that the sides of the planting pit are scarified to help in root penetration.

**NISQUALLY STATE PARK
NEW FULL SERVICE PARK – PHASE 2**

7. Place the plant in an upright and vertical position in the center of the hole, with the side containing the fullest amount of foliage faced toward the primary direction viewed by the public.
8. Weeds in the top of the root balls shall be removed prior to planting.
9. The root crown shall not be buried in the originally dug root ball.
10. If the root crown of a plant is found to be buried in the root ball, the Contractor shall gently remove soil from the top of the root ball to expose the top of the root crown. If this measure is insufficient to gain acceptance from the Owner, then the Contractor shall immediately replace the plant with another acceptable specimen.
11. Place Topsoil Type A around ball in layers, tamping to settle backfill and eliminate voids and air pockets.
12. When pit is approximately ½ back filled, water thoroughly before placing remainder of backfill.
13. Allow water to infiltrate into soil.
14. Repeat watering until no more is absorbed.
15. Water again after placing and tamping final layer of backfill.
16. Stake trees and large shrubs as indicated on the Drawings.
17. Fine grade the planting area to remove rocks and debris, and create a smooth, uniform surface that provide positive drainage, and is free of humps, and low spots.
18. Apply the mulch as indicated on the Drawings.
19. Maintain plants in a vigorous thriving condition by watering, correct pruning practices, cultivating, weeding, fertilizing, and other necessary operations, until Substantial Completion is awarded.

3.4 30 DAY MAINTENANCE AND ESTABLISHMENT PERIOD

- A. The 30-day Maintenance and Establishment Period will begin on the date Substantial Completion is issued by the Owner's Representative.
- B. Maintenance shall include, but not be limited to, watering, weeding, monitoring and treating any disease and/or pest-problems, and all other maintenance requirements specified below, required to keep all plant materials in a normal healthy growing condition.
- C. Application of pesticides shall be done only as approved by the Owner by workers possessing a State Pesticide Certification.
- D. Keep plant materials and planting areas free from weeds and grasses by the application of suitable herbicides per manufacturer's instructions, or hand pulling.
- E. Consult with the Owner before pruning plant materials.
- F. Staking, guys, and saucers shall be kept intact and adjusted as required to provide firm support.
- G. Maintain fully formed watering saucers.
- H. Replace all dead or dying plants when no longer in a satisfactory growing condition as determined by the Owner, for the duration of the period.

**NISQUALLY STATE PARK
NEW FULL SERVICE PARK – PHASE 2**

- I. Make plant materials replacements within seven (7) working days of notification from the Owner. Remove dead plant materials within two (2) working days of notification and mark planting plan showing the exact location of replaced areas.
- J. Replace mulched areas that are damaged, to the specified compacted depth, using the specified mulch.
- K. Do not add new mulch over existing mulch contaminated with soil or other deleterious materials.
- L. The fertilization, watering, and maintenance requirements specified are the minimum requirements, and do not relieve the Contractor of the responsibility to provide acceptable plant materials. Contractor shall provide all additional fertilizer applications, waterings, and maintenance methods necessary beyond the minimum requirements specified in this Section to provide acceptable plant materials at Contractor's cost as part of the unit price.

3.5 OWNER'S RECOURSE FOR LACK OF REPLACEMENT

- A. It is agreed that the Owner will suffer damage and be put to additional expense in the event that the Contractor does not perform duties as specified above, and as it may be difficult to accurately compute the amount of such damage, the Contractor hereby expressly covenants and agrees to the following maintenance performance measures:
- B. **Replacing Dead or Dying Plants:** The Owner will issue the Contractor up to two written notices during the Maintenance Period to replace dead or dying plants. Whereupon the Contractor shall have seven (7) calendar days, per notice, to replace the dead or dying plants. If plant replacement is not performed after the second notice, the Owner shall terminate the contracts with the Contractor and contact the Contractor's Bonding Company to perform the work for the rest of the maintenance period.
- C. **Regular Watering:** The Owner will issue the Contractor up to two written notices during the maintenance period to water the contract plants. Whereupon the Contractor shall have seven (7) calendar days, per notice, to water contract plants. If plant irrigation is not performed after the second notice, the Owner shall terminate the contract with the Contractor and contact the Contractor's Bonding Company to perform the work for the rest of the maintenance period.

3.6 ACCEPTANCE OF PLANT MATERIAL INSTALLATION

- A. After completion of all plant material installation and the 30 day maintenance period, the Owner will review all plantings for compliance.
- B. Areas with acceptable, healthy, and vigorous growing plants, and free from all visible injury or deleterious conditions, with clean, uniform mulch layer at the depth specified, as determined by the Owner's Representative, shall be considered acceptable.
- C. Once the date of acceptance has been agreed upon between the Owner and Contractor, the Owner shall immediately take over the maintenance of all accepted plant materials.

**NISQUALLY STATE PARK
NEW FULL SERVICE PARK – PHASE 2**

- D. Plant materials and planting areas not containing acceptable plant materials or condition, or areas damaged through any other cause prior to this inspection, shall be repaired using the material specified for that area as herein specified at the Contractor's expense, including specified maintenance, until an acceptable condition is achieved.

3.7 CLEAN-UP

- A. Regular policing of the project site of trash and project debris will be required.
- B. The disposal to all trash will be the Contractors' responsibility.
- C. Repair and replace broken or defective pavement, fencing, utilities, and all existing or constructed improvements damaged by the work of this section, as directed by the Owner's Representative.
- D. Clean and remove tire tracks on all pavement, related to the work of this Section.
- E. Clean and remove all material stockpiles and waste materials, dispose legally off site, and restore pavements, natural turf areas, and planting beds.
- F. Sweep concrete pavement and wash free of stains, discoloration, dirt, infill materials, and other foreign material just prior to final inspection.
- G. Remove surplus planting materials and rubbish from planting beds, rake beds neatly to an even, fine grade around all plants and wash clean all paved areas.
- H. Leave project clean, and free from all plating operation debris.

END OF SECTION

**NISQUALLY STATE PARK
NEW FULL SERVICE PARK – PHASE 2**

SECTION 331300 – WATER DISTRIBUTION

PART 1 - GENERAL

1.1 SUMMARY

- A. Work includes the procurement and installation of water lines, valves, and appurtenances.

1.2 RELATED DOCUMENTS

- A. Drawings and general provisions of the Contract, including General Conditions and Specification Sections apply to this Section.

1.3 STANDARD SPECIFICATIONS

- A. All work to be performed and materials to be used shall be in accordance with the current edition of the Standard Specifications for Road, Bridge, and Municipal Construction, and the current Standard Plans as published by the Washington State Department of Transportation (WSDOT), unless otherwise indicated herein.
- B. Contractor shall have one (1) copy of the current edition of the Standard Specifications and all amendments therein, and applicable WSDOT Standard Plans at job site.
- C. Standard Specifications apply only to performance and materials and how they are to be incorporated into the work. Legal/contractual relationship sections and the measurement and payment sections do not apply to this document.
- D. All work shall conform to the specifications listed in WAC 246-290 (Group A Public Water Supplies) and the latest editions of the following references: The Washing State Department of Health Water System Design Manual, Washington State Department of Transportation (WSDOT) standard specifications, APWA standard specifications, AWWA standards, UPC, and the applicable county rules, regulations, and ordinances. The standards are listed in order of preference in the event that a conflict in standard arises.

1.4 QUALITY ASSURANCE

- A. Contractor is responsible for all effort necessary to complete work in accordance with drawings and standards, until certified by the engineer and state and local agencies for correct installation and satisfactory operation of all equipment.

1.5 SUBMITTALS

- A. Product Data: Submit manufacturer's product data, standard drawings, and catalog cuts for the following:

**NISQUALLY STATE PARK
NEW FULL SERVICE PARK – PHASE 2**

1. Pipe and pipe fittings
2. Valves
3. Connections, bends, and saddles
4. All miscellaneous components and appurtenances

1.6 STORAGE, AND HANDLING

- A. Contractor shall practice the preventive and corrective measures during construction specified in Section 4 of AWWA Standard C651 which covers requirements for protecting the pipe and fittings from contamination and describes disinfection procedures to be followed during pipe installation.

PART 2 - PRODUCTS

2.1 PIPE AND FITTINGS

- A. Pipe for water service connections shall be high-density polyethylene(HDPE) PE 4710, DR 11 (200 psi), FM approved, NSF-61 approved and in compliance with NFPA 24.
- B. Fittings for water service connections shall conform to Section 9-30.6(4) SERVICE FITTINGS of the WSDOT Standard Specifications.

2.2 VALVES

- A. Valves for service connections shall be full port brass bodied ball valves. Valves shall be rated for a minimum of 200 psi working pressure. Valves shall be Ford B61-444 ball valves or engineer approved equal.
- B. Valves for distribution line piping less than 3” diameter shall be Resilient Wedge Gate Valves conforming to AWWA C509 with 2” square operation nut and non-rising stem.
- C. Valves for water main greater than 3” diameter shall be Resilient Wedge Gate Valves conforming to AWWA C509 with 2” square operation nut and non-rising stem.

2.3 DETECTABLE MARKING TAPE

- A. Detectable marking tape shall meet the requirements of Section 9-15.18 DETECTABLE MARKING TAPE of the WSDOT Standard Specifications.

2.4 BLOW-OFF ASSEMBLY

- A. Blow-off assemblies shall be provided in conformance with the Plans.

**NISQUALLY STATE PARK
NEW FULL SERVICE PARK – PHASE 2**

2.5 WATER METERS

- A. Meter shall be Neptune T-10, bronze body, cubic-foot.
- B. Service meters shall be consistent for all services for the development, submitted to Engineer for approval, sized per Plans.

2.6 CONCRETE (THRUST BLOCKING)

- A. Unreinforced concrete shall be commercial class conforming to Section 6-02.3(2)B of the current Standard Specifications and Standard Plans for Road, Bridge and Municipal Construction, as published by the Washington State Department of Transportation and as shown in the plans.

2.7 TRENCH BACKFILL

- A. Gravel Backfill for Pipe Zone Bedding shall meet the requirements of WSDOTSS 9-03.12(3).
- B. Trench Backfill material shall meet WSDOTSS 9-03.19 Bank Run Gravel for Trench Backfill. Common Borrow A may be used Trench Backfill provided the material is processed through a 2-1/2" screen.

PART 3 - EXECUTION

3.1 PIPE AND FITTINGS

- A. HDPE pipes shall be installed with heat fusion joining methods per manufacturer recommendations.
- B. C900 PVC pipes shall be installed in conformance with Section 7-09.3 of the WSDOT Standard Specifications.
- C. Detectable Marking tape shall be installed over all water lines including service lines. The tape shall be placed approximately 1-1.5 feet below the ground surface and shall extend the full pipe length. Detectable marking tape shall meet the requirements of Section 9-15.18 of the WSDOT Standard Specifications.
- D. Direct Bury, U.S.E. 14 gauge blue coated copper tracer wire shall be installed with all water lines. Tracer wire shall be wrapped around the pipe or taped to the pipe at maximum intervals of 10-feet.

3.2 VALVES

- A. Valves shall be installed in conformance with Section 7-12.3 of the WSDOT Standard Specifications.
- B. Valves shall be installed with valve box. Valves within traffic areas or dedicated pathways shall have traffic-rated valve box.

**NISQUALLY STATE PARK
NEW FULL SERVICE PARK – PHASE 2**

3.3 SERVICE CONNECTIONS

- A. Service connections shall be installed as identified in the Plans.

**NISQUALLY STATE PARK
NEW FULL SERVICE PARK – PHASE 2**

3.4 TESTING AND STERILIZATION

- A. Testing and sterilization of the water mains shall be in conformance with Section 7-09.3 of the WSDOT Standard Specifications.
- B. Testing and sterilization of the service connections shall be in conformance with Section 7-15.3(1) of the WSDOT Standard Specifications.

END OF SECTION

**NISQUALLY STATE PARK
NEW FULL SERVICE PARK – PHASE 2**

SECTION 333300 – SANITARY SEWERS

PART 1 - GENERAL

1.1 DESCRIPTION

- A. The work includes constructing sanitary sewer mains, side sewers, and manholes.

1.2 STANDARD SPECIFICATIONS

- A. All work to be performed and materials to be used shall be in accordance with the current edition of the Standard Specifications and Standard Plans for Road, Bridge and Municipal Construction, as published by the Washington State Department of Transportation (WSDOT), unless otherwise indicated herein.
- B. The Contractor shall have one copy of the Standard Specifications and Standard Plans at the job site.
- C. The Standard Specifications apply only to performance and materials and how they are to be incorporated into the work. The legal/contractual relationship sections and the measurement and payment sections do not apply to this document.

1.3 RELATED DOCUMENTS

- A. Drawings and general provisions of the Contract, including General Conditions and Specification Sections apply to this Section.

1.4 SUBMITTALS

- A. Product Data: Submit manufacturer's product data, standard drawings, and catalog cuts for the following:
 - 1. Pipe and pipe fittings
 - 2. Manhole structures and appurtenances
 - 3. All miscellaneous components and appurtenances

PART 2 - PRODUCTS

2.1 PIPE AND FITTINGS

- A. Sewer pipe and fittings shall be solid wall PVC conforming to Section 9-05.12(1) of the WSDOT Standard Specifications. All pipe and fittings shall be legibly and permanently marked with type and class.

**NISQUALLY STATE PARK
NEW FULL SERVICE PARK – PHASE 2**

2.2 MANHOLES

- A. Manholes shall be precast concrete structures conforming to Section 9-05.50(2) of the WSDOT Standard Specifications.
- B. Manhole gaskets, metal castings, and appurtenances shall conform to the standard details in the Plans and Section 7-05.2 of the WSDOT Standard Specifications.

PART 3 - EXECUTION

3.1 PIPE AND FITTINGS

- A. Sanitary Sewers shall be constructed in accordance with Section 7-08.3 of the WSDOT Standard Specifications.
- B. Valves shall be installed with valve box. Valves within traffic areas or dedicated pathways shall have traffic-rated valve box.
- C. Plugs and stubs for future sewer pipes shall be one full stick of sewer pipe secured in place with a gasketed joint at the manhole and installed at the line and grade as shown on the plans. The installed pipe shall have a temporary cap installed that can be removed in the future.

3.2 MANHOLES

- A. Manholes shall be constructed in accordance with Section 7-05.3 of the WSDOT Standard Specifications.

3.3 CLEANING AND TESTING

- A. Sewers and appurtenances shall be cleaned and tested in accordance with Section 7-17.3(2) of the WSDOT Standard Specifications.

END OF SECTION

**NISQUALLY STATE PARK
NEW FULL SERVICE PARK – PHASE 2**

SECTION 334210 – TRENCH DRAIN

PART 1 - GENERAL

1.1 SUMMARY

A. Section Includes:

1. Decorative cast metal trench drain grates.
2. Metal frames and accessories.

B. Related Requirements:

1. Section 033010 – Cement Concrete Paving

1.2 DEFINITIONS

A. ADA: Americans with Disabilities Act.

1.3 REFERENCE STANDARDS

A. General: Use most current standard, unless otherwise indicated by specific date.

B. American Association of State Highway and Transportation Officials (AASHTO):

1. AASHTO M 306 - Standard Specification for Drainage, Sewer, Utility, and Related Castings.

C. ASTM International:

1. ASTM A36 - Standard Specification for Carbon Structural Steel.
2. ASTM A48 - Standard Specification for Grey Iron Castings.
3. ASTM A123 - Standard Specification for Zinc (Hot-Dip Galvanized) Coatings on Iron and Steel Products.
4. ASTM A153 - Standard Specification for Zinc Coating (Hot-Dip) on Iron and Steel Hardware.
5. ASTM A536 - Standard Specification for Ductile Iron Castings
6. ASTM B26 - Standard Specification for Aluminum-Alloy Sand Castings.
7. ASTM B584 - Standard Specification for Copper Alloy Sand Castings for General Applications.
8. ASTM E303 - Standard Test Method for Measuring Surface Frictional Properties Using the British Pendulum Tester

D. American Welding Society:

1. AWS D1.1 - Structural Welding Code - Steel.
2. AWS D1.2 - Structural Welding Code - Aluminum.

**NISQUALLY STATE PARK
NEW FULL SERVICE PARK – PHASE 2**

3. AWS D1.6 - Structural Welding Code - Stainless Steel.

E. Military Standardization Documents:

1. MIL A-8625 - Anodic Coatings for Aluminum and Aluminum Alloys.

1.4 COORDINATION

A. Coordinate Work of this Section with:

1. Placement of frames.
2. Size of cast-in-place curb and pavement openings.
3. Premanufactured drainage assemblies provided under other Sections.

1.5 SUBMITTALS

A. Product Data: Indicate compliance with applicable Reference Standards.

B. Shop Drawings: Indicate details of each type and size of grate, component supports, anchorages, openings, perimeter construction details, and tolerances.

1. Where custom design or layout has been furnished by the Design Professional, submit CAD file, in addition to other Drawings, to indicate compliance with design intent.
2. Where intent of Design Professional cannot be met due to size, material, or casting limitations, clearly indicate exceptions on Submittal documents.
3. Submit grating Shop Drawings in coordination with submittals for drainage assemblies furnished under other Sections.

C. Samples: Submit [two] Rain 6"x24" Heel Proof cast metal samples, 6 by 24 inch in size, illustrating finish, color, and texture.

D. Delegated Design Submittals: Submit certified AASHTO ratings or signed and sealed Shop Drawings with design calculations for gratings subjected to vehicular loads.

1. Licensed Professional: Engineer experienced in design and anchorage of load-bearing trench grates and licensed at Project location.

1.6 SUSTAINABLE DESIGN SUBMITTALS

A. Manufacturer's Certificate: Certify that products meet or exceed specified sustainable design requirements.

B. Product Cost Data: Submit cost of products to verify compliance with Project sustainable design requirements. Exclude cost of labor and equipment to install products.

**NISQUALLY STATE PARK
NEW FULL SERVICE PARK – PHASE 2**

1. Provide cost data for the following products:
 - a. Salvaged, refurbished, and reused products.
 - b. Products with recycled material content.
 - c. Regional products.

1.7 QUALIFICATIONS

- A. Welders and Welding Procedures: AWS D.1 qualified within previous 12 months for employed weld types.

1.8 WARRANTY

- A. Provide manufacturer's standard one year warranty on products and assemblies.

1.9 EXISTING CONDITIONS

- A. Field Measurements: Verify field measurements of conditions affecting drainage grates prior to fabrication. Indicate field measurements provided by General Contractor or other parties on Shop Drawings

PART 2 - PRODUCTS

2.1 PERFORMANCE AND DESIGN CRITERIA

- A. General: Conform to local code(s) as indicated on Drawings for applicable loads.
- B. Load Designation Required; AASHTO M 306.
 1. Non-traffic.
 2. Light Duty

2.2 DRAIN GRATINGS

- A. Acceptable Manufacturers:
 1. Iron Age Designs; www.ironagegrates.com; 877-418-3568.
 2. Substitutions per Section 016000 Product Requirements.

2.3 SUSTAINABILITY CHARACTERISTICS

- A. Material and Resource Characteristics:
 1. Recycled Content Materials: Furnish materials with minimum of 80 percent recycled metal content.

**NISQUALLY STATE PARK
NEW FULL SERVICE PARK – PHASE 2**

2. Regional Materials: Furnish materials extracted, processed, and manufactured within 500 miles of Project Site.
3. Cradle to Cradle Certified

2.4 GRATE MATERIALS

- A. Cast Ductile Iron: ASTM A536; alloy 65-45-12

2.5 TRENCH DRAIN GRATINGS

- A. Width: 5.88 inches
- B. Length per Section: 23.94 inches
- C. Basis of Design Pattern: Rain 6" x 24" Heel Proof by Iron Age Designs
 1. Product ID: RNN6-24I03HP
- D. Number of Sections per Drawings.
- E. Frames:
 1. Galvanized Steel: ASTM A123.

2.6 FABRICATION

- A. Fabricate drainage gratings to accommodate design loads and to sizes indicated.
- B. Fabricate grates to comply with ADA for maximum opening size, offset of surfaces, and slip resistance. Grates shall have a minimum slip resistance (Pendulum Test Value) of 5.5 or better, per ASTM E303.
 1. Provide grates with enhanced heel-proof design, with no opening wider than 1/4-inch.

2.7 GRATE FINISHES

- A. Clean surfaces of rust, scale, grease, and foreign matter prior to finishing.

2.8 ACCESSORIES

- A. Vandal Resistant Bolts: Stainless steel, 1/4 x 20 fasteners. Prefabricate frames with fasteners where shown on Shop Drawings.
 1. Fasteners to attach drainage grates in this Section to drain bodies specified under other Sections must be provided by manufacturers of those products.

**NISQUALLY STATE PARK
NEW FULL SERVICE PARK – PHASE 2**

PART 3 - EXECUTION

3.1 EXAMINATION

- A. Verify that overall opening sizes and dimensional tolerances are acceptable.
- B. Verify that fixtures placed by other trades are completed, and that openings and penetrations are accurately positioned.
- C. Verify that preparation work is complete, including removal of soil material and trash from trench and area drain assemblies.

3.2 INSTALLATION

- A. For cast-in-place frames, furnish to entity responsible for adjacent curbs or pavements.
- B. For field-anchored frames, anchor by expansion bolts to prepared openings using anchors of type and number recommended by manufacturer.
- C. Ensure that top of frame and grating is flush with, or no greater than 1/8-inch lower than, adjacent pavement surfaces.
- D. Place gratings securely in prepared openings, with no warping or slippage.
- E. Secure where indicated, or as needed to prevent movement. Allow for maintenance removal.

3.3 TOLERANCES

- A. Maximum Space Between Adjacent Sections: 1/4-inch.
- B. Maximum Variation from Top Surface Plane of Adjacent Sections: 1/8-inch.

3.4 PROTECTION AND CLEANING

- A. Protect completed gratings until time of Substantial Completion.
- B. Clean damaged coatings according to manufacturer recommendations.

END OF SECTION

**NISQUALLY STATE PARK
NEW FULL SERVICE PARK -PHASE 2**

SECTION 334000 - STORMWATER UTILITIES

PART 1 - GENERAL

1.1 DESCRIPTION

- A. The Work described in this Section includes installing the stormwater conveyance piping and appurtenances to serve the park uses. Stormwater utility work in this section includes, but is not limited to, the following.
 - 1. Construction of gravity storm sewer pipes catch basins, roof drains, culverts, flow dispersion trench and cleanouts.
 - 2. Trench excavation, pipe bedding, and gravel backfill.

1.2 REFERENCES

- A. Reference Standards – Current edition at date of bid:
 - 1. Washington State Department of Transportation (WSDOT) / American Public Works Association (APWA)
 - a. Standard Specifications for Road, Bridge, and Municipal Construction.
 - b. Standard Plans for Road, Bridge, and Municipal Construction
- B. Washington State Department of Ecology’s Stormwater Management Manual for Western Washington

1.3 SUBMITTALS

- A. Submit manufacturer’s literature and data for all pipe, fittings, castings, catch basins, area drains, grates, and other manufactured products.

1.4 RELATED WORK

- A. Coordinate related work specified in other parts of the Project Specifications, including, but not limited to the following:
 - 1. Temporary Erosion and Sedimentation Control – 01 57 13
 - 2. Earth Moving – 31 20 00
 - 3. Geotechnical Report

**NISQUALLY STATE PARK
NEW FULL SERVICE PARK -PHASE 2**

PART 2 - PRODUCTS

2.1 Materials

- A. Solid Wall PVC Storm Sewer Pipe shall meet the requirements of section 7-04 and 9-05.1(5) (PVC Drain Pipe) of the WSDOT Standard Specifications (WSDOTSS).
- B. Catch basins shall meet the requirements of section 7-05 and 9-05.50(3) of the WSDOT Standard Specifications.
- C. Corrugated Polyethylene Culvert Pipe shall meet the requirements of WSDOTSS 9-05.19. Flared End Sections shall comply with WSDOTSS 7-02.3(2).
- D. Flow Dispersion Trench shall consist of the following materials:
 - 1. Washed rock shall meet the requirements of section 9-03.12(5) Gravel Backfill for Drywells of the WSDOT Standard Specifications
 - 2. Geotextile shall be non-woven meeting the requirements of section 9-33 of the WSDOT Standard Specifications, Class A geotextile for underground drainage with low survivability (Table 2).
 - 3. Perforated pipe and cleanouts shall meet the requirements of section 9-05.2(6), or 9-05.2(7) type SP with Class 2 perforations, of the WSDOT Standard Specifications.
 - 4. Wood for Flow Dispersion Trench shall be Hem Fir, S4S, WCLB Para. 118a Construction, unless otherwise indicated, grade marked, and the following requirements: Comply with ASL PS 20 and applicable grading rules of respective grading and inspecting agency for species and product indicated. Manufacture to sizes and patterns using kiln dried lumber. Wood shall be pressure treated with ACQ-D to 0.40 lbs/sf.
 - 5. Bolts, Nuts, and Washers: ASTM A325, galvanized to ASTM A153.
- E. Gravel Backfill for Pipe Zone Bedding shall meet the requirements of WSDOTSS 9-03.12(3).
- F. Trench Backfill material shall meet WSDOTSS 9-03.19 Bank Run Gravel for Trench Backfill. Common Borrow A may be used Trench Backfill provided the material is processed through a 2-1/2" screen.

PART 3 - EXECUTION

3.1 PREPARATION

- A. All temporary erosion and sediment control measures shall be in place prior to land disturbance.

3.2 TRENCHING AND EXCAVATION

- A. Trenching and excavation for the stormwater conveyance components shall be done in accordance with sections 7-05.3 and 7-08.3 of the WSDOT Standard Specifications. Salvage all boulders per Section 31 20 00 Earth Moving. Excavated material may be used as Common

**NISQUALLY STATE PARK
NEW FULL SERVICE PARK -PHASE 2**

Borrow A if the material meets the sieve requirements of Common Borrow A as determined by the Owner.

3.3 PIPE INSTALLATION

- A. Installation of the stormwater conveyance components shall be done in accordance with sections 7-08.3 of the WSDOT Standard Specifications.

3.4 MANHOLES, INLETS, CATCH BASINS AND DRYWELLS

- A. Manholes, Inlets, Catch Basins and Drywells shall be installed in compliance with WSDOTSS 7-05 Manholes, Inlets, Catch Basins and Drywells.

3.5 FLOW DISPERSION TRENCH

- A. Install Flow Dispersion Trench level as shown and described in Plans. The top of the Flow Dispersion Trench shall be Gravel Backfill for Drywells; no topsoil, mulch or any other material shall be placed over the Flow Dispersion Trench.

END OF SECTION

**NISQUALLY STATE PARK
NEW FULL SERVICE PARK – PHASE 2**

SECTION 462010 – WATER TREATMENT EQUIPMENT

PART 1 - GENERAL

1.1 SUMMARY

- A. This Section includes procurement and installation of potable water treatment devices and associated appurtenances.

1.2 RELATED DOCUMENTS

- A. Drawings and general provisions of the Contract, including General and Supplementary Conditions and Division 01 Specification Sections, apply to this Section.

1.3 STANDARD SPECIFICATIONS

- A. All work shall conform to the specifications listed in WAC 246-290 (Group A Public Water Supplies) and the latest editions of the following references: The Washing State Department of Health Water System Design Manual, Washington State Department of Transportation (WSDOT) standard specifications, APWA standard specifications, AWWA standards, UPC, and the applicable county rules, regulations, and ordinances. The standards are listed in order of preference in the event that a conflict in standard arises.

1.4 SUBMITTALS

- A. Product Data: For each type of product indicated.
- B. Shop drawing showing pump house plumbing and electrical.
- C. Operation and Maintenance Data: For water valves and specialties to include in emergency, operation, and maintenance manuals.
- D. Record Drawings: Contractor shall maintain a set of As-Built Drawings to indicate all deviations from the original design.
 - 1. Changes shall be legibly documented on Drawings while work is in progress.
 - 2. Final “As-Built” drawings shall be prepared by the Contractor on a clean set of drawings after final inspection.
 - 3. Final “As-Built Drawings” shall be delivered to the Engineer for transmittal to the Owner

1.5 QUALITY ASSURANCE

- A. Contractor is responsible for all effort necessary to complete work in accordance with drawings and standards, until certified by the engineer and state and local agencies for correct installation and satisfactory operation of all equipment.

**NISQUALLY STATE PARK
NEW FULL SERVICE PARK – PHASE 2**

- B. Piping materials shall bear label, stamp, or other markings of specified testing agency.
- C. NSF Compliance: All products in contact with potable water shall:
 - 1. Comply with NSF 61, "Drinking Water System Components - Health Effects; Sections 1 through 9."
 - 2. Comply with NSF 372, "Drinking Water System Components – Lead Content."

PART 2 - PRODUCTS

2.1 GENERAL

- A. All system components in substantial contact with water must be NSF 61 approved for drinking water. Chemical additives must be NSF 60 approved.

2.2 PERISTALTIC INJECTION PUMP

- A. Pump and tubing must be compatible with 12.5% chlorine solution
- B. Tubing must be NSF-61 listed
- C. Field adjustable feed rate control
- D. Injection pressure of up to 100 psi
- E. A ¼" check valve injection fitting shall be installed, or Engineer approved equal
- F. Tubing material shall be PP Santoprene EPDM

2.3 PRESSURE RELIEF VALVE

- A. Pressure relief valve shall be designed for drinking water. Pressure relief valve shall comply with the lead-free provisions of the Safe Drinking Water Act and meet the following criteria:
 - 1. Bronze/Brass body and bonnet
 - 2. Connections: Threaded NPT
 - 3. Pressure relief setting: 100 psi
- B. Pressure relief valve shall be a Kunkle 913BJHB06-JE0100, or Engineer approved equal.

2.4 FILTER VESSEL

- A. Filtration housing shall be a fiberglass vessel with a top mounted valve designed for drinking water applications.
- B. Minimum design pressure rating shall be 100 psi or greater.

**NISQUALLY STATE PARK
NEW FULL SERVICE PARK – PHASE 2**

2.5 FILTER MEDIA

- A. Filter media shall be Greensand Plus Anthracite, Sand, and Gravel.

2.6 FILTER CONTROLS

- A. Minimum design pressure rating of filter control valves shall be 125 psi.
- B. Input control shall consist of a minimum of a master/slave input/output port, 2 dry contact inputs, and 1 4-20 mA input.
- C. Output control shall consist of a minimum of one master/slave input/output port, 1 MAV control circuit output, 2 dry contact output relays (minimum rating 1A, 30VAC/DC).
- D. One master unit shall be equipped with an expanded communication ports for connecting 3 additional units.
- E. Control valve must be fully programable and compatible for communication between other treatment vessel control.
- F. Filter controls will contain a Clack 2-inch WS2H control valve with bypass and a 2-inch Clack 3-port motorized alternating valve (MAV) or Engineer approved equal for each treatment vessel. valves, 3-way valves, and other system controls.

2.7 FLOW RESTRICTORS

- A. Flow restrictors shall be noted per specification on filter head detail drawing. Restrictors are Dole Valves, or Engineer approved equal.

2.8 SAMPLE TAPS

- A. Sample cocks shall be standard ¾" 90-degree hose bibs (globe valve). Where noted, smooth nose sample taps shall be used in place of standard threaded hose bibs.

2.9 PIPE AND FITTINGS

- A. All piping and plumbing shall be SCH 80 PVC or SCH 40 GIP unless otherwise specified.

2.10 SIGNAL WIRE

- A. Signal wire from pumphouse to reservoir transducer shall be a minimum of 18 AWG or as required by applicable code.

PART 3 - EXECUTION

**NISQUALLY STATE PARK
NEW FULL SERVICE PARK – PHASE 2**

3.1 DELIVERY, STORAGE, AND HANDLING

- A. Deliver piping with factory-applied end caps. Maintain end caps through shipping, storage, and handling to prevent pipe-end damage and to prevent entrance of dirt, debris, and moisture.
- B. Protect stored piping and equipment from moisture and dirt. Elevate above grade.
- C. Protect flanges, fittings, and specialties from moisture and dirt.

3.2 PERISTALTIC INJECTION PUMP

- A. Chlorine injection pump on dedicated circuit controlled in parallel with well pump operation via relay.
- B. The injector nozzle shall extend into the middle of the fill pipe. The trimmed side of the nozzle shall be installed facing up-stream.

3.3 PRESSURE RELIEF VALVE

- A. The pressure relief valve shall be discharged through the exterior wall. Discharge piping shall be free of any fixtures and shall be screened at the outlet.

3.4 FILTER VESSEL

- A. Treatment vessels shall be placed no closer than 3” from the exterior walls and 6” from other vessels.
- B. All tanks shall be leveled with shims as required to within 1% slope.

3.5 FILTER MEDIA

- A. All plumbing components, pipe thread, and other sensitive components shall be protected from entry of foreign material during media addition.
- B. The Contractor shall perform initial media flushing to remove fines and properly bed media.
- C. Engineer shall be present during filter vessel bedding. The Contractor must provide advance notice to Engineer and plan to bed vessels in one day, if possible, to reduce excessive visits by Engineer.

3.6 FILTER CONTROLS

- A. Control valves shall be installed and plumbed per manufacturer’s direction.
- B. The Engineer shall verify that the Treatment Skid, as installed by the Contractor, is compatible with other adjacent equipment, instruments, controls and structures to allow operation of system per the design intent.

**NISQUALLY STATE PARK
NEW FULL SERVICE PARK – PHASE 2**

3.7 SAMPLE TAPS

- A. Sample taps shall be oriented to discharge downward, be no less than 12” from the floor and positioned direct flow toward the floor drain. Sample taps shall provide an even, gently stream of water.

3.8 PIPE AND FITTINGS

- A. The Contractor shall secure all components according to the manufacturer’s installation directions.
- B. Contractor shall support piping to protect the plumbing and components from damage and impose minimal loads and stresses on the equipment.

3.9 SIGNAL WIRE

- A. Connect reservoir level transducer to the VFD and well pump meeting manufacturers direction. Reservoir operational levels shall be at the following setpoints: 13.4 and 14.4 feet above the reservoir foundation.
- B. Operation of the controls will be confirmed by the Engineer.

3.10 STARTUP AND TESTING

- A. The Contractor shall instruct Owner’s personnel in the operation and maintenance of all components and conduct a training seminar at the site. Training shall thoroughly convey all relevant operational subject matter to the operator(s) and owner’s representative(s).

3.11 COMMISSIONING

- A. The treatment plant will be considered effective if the post-treatment iron and manganese onsite and lab samples are below 50% of their respective maximum contaminant levels (MCL’s).
- B. Results of the treatment plant must be consistently effective for a minimum of two backwash cycles.
- C. If the treatment system fails to demonstrate effective results, the Contractor shall troubleshoot and/or modify and/or replace the necessary equipment to bring the system into compliance.

END OF SECTION