

THIS DOCUMENT AND ATTACHMENT(S) ARE AVAILABLE FOR DOWNLOAD AT  
[http://www.bxwa.com/bxwa\\_toc/pub/1687/toc.html](http://www.bxwa.com/bxwa_toc/pub/1687/toc.html)  
AN EMAIL NOTIFICATION WAS SENT TO REGISTERED PLANHOLDERS. FAILURE TO  
ACKNOWLEDGE RECEIPT ON THE BID FORM DOES NOT AFFECT THE BIDDER'S  
OBLIGATION FOR COMPLIANCE.



## ADDENDUM NO. 1

### WASHINGTON STATE PARKS AND RECREATION COMMISSION LEWIS AND CLARK TRAIL STATE PARK COMFORT STATION RENOVATION EW-C6530

DATE: December 5, 2024

**ATTENTION TO PLANHOLDERS OF RECORD.** The following revisions are hereby made a part of the Contract Documents. Please be sure to acknowledge all Addenda on the Bid Form.

#### **CHANGES TO THE DRAWINGS**

- The posted drawing set has been revised.
- On **Sheet 2**, a keynote has been added to indicate the replacement of the sidewalk around the building. This note was not included in the original posted set.

#### **Action Required:**

Please remove the original drawing set in its entirety and replace it with the attached revised set, which includes **Sheets 1-17**.

#### **ATTACHMENTS**

- Revised Drawings (17 sheets).
- Pre-Bid Meeting Sign-In Sheet.

For questions or further clarification, please contact Ned Warnick, Project Representative at (509) 332-3113, [nwarnick@designwestpa.com](mailto:nwarnick@designwestpa.com), or State Parks Representative Alex McMurry at (360) 902-0930, [alex.mcmurry@parks.wa.gov](mailto:alex.mcmurry@parks.wa.gov).

*Brett Taylor*

\_\_\_\_\_  
Brett Taylor, Procurement Coordinator  
Contracts and Grants Program

12/05/24

\_\_\_\_\_  
Date

END OF ADDENDUM NO. 1

# WASHINGTON STATE PARKS & RECREATION COMMISSION

SOPHIA DANENBERG, CHAIR

KEN BOUNDS

LAURIE CONNELLY

MICHAEL LATIMER

SCOTT MERRIMAN

ALI RAAD

HOLLY WILLIAMS

DIANA DUPUIS, DIRECTOR



APPROVED FOR CONSTRUCTION

*Jason Both* 9/23/2024  
REGION MANAGER date

*Kyle Murphy* 9/24/2024  
CAPITAL PROGRAM MANAGER date

Area Manager: AUDRA SIMS

## LEWIS & CLARK TRAIL STATE PARK COMFORT STATION RENOVATION

### INDEX

SHEET	DESCRIPTION
1	COVER SHEET
2	ARCHITECTURAL SITE PLAN
3	DEMO PLAN, FLOOR PLAN AND REFLECTED CEILING PLAN
4	ENLARGED FLOOR PLAN
5	INTERIOR ELEVATIONS, ROOM SCHEDULE AND DISABLE ACCESSIBLE MOUNTING HEIGHTS
6	DETAILS
7	MECHANICAL SCHEDULES, NOTES, LEGENDS, ABBREVIATIONS
8	MECHANICAL DEMO PLAN HVAC
9	MECHANICAL FLOOR PLAN HVAC
10	PLUMBING SCHEDULES, NOTES, LEGENDS, ABBREVIATIONS
11	PLUMBING DEMO PLAN
12	PLUMBING FOUNDATION PLAN
13	PLUMBING FLOOR PLAN
14	ELECTRICAL LEGENDS & ABBREVIATIONS
15	ELECTRICAL SCHEDULES AND SINGLE LINE
16	ELECTRICAL SITE PLAN
17	ELECTRICAL DEMO PLAN AND FLOOR PLAN

VICINITY MAP



HIGHWAY US-12  
STATE PARK LOCATION

LATITUDE: 46.286657 LONGITUDE: -118.073462

PROJECT LOCATION



36149 US-12 DAYTON WA 99328  
SECTION 4 T9N R38E  
COLUMBIA COUNTY TAX PARCEL NUMBER 2-009-38-004-0000  
PROJECT LOCATION

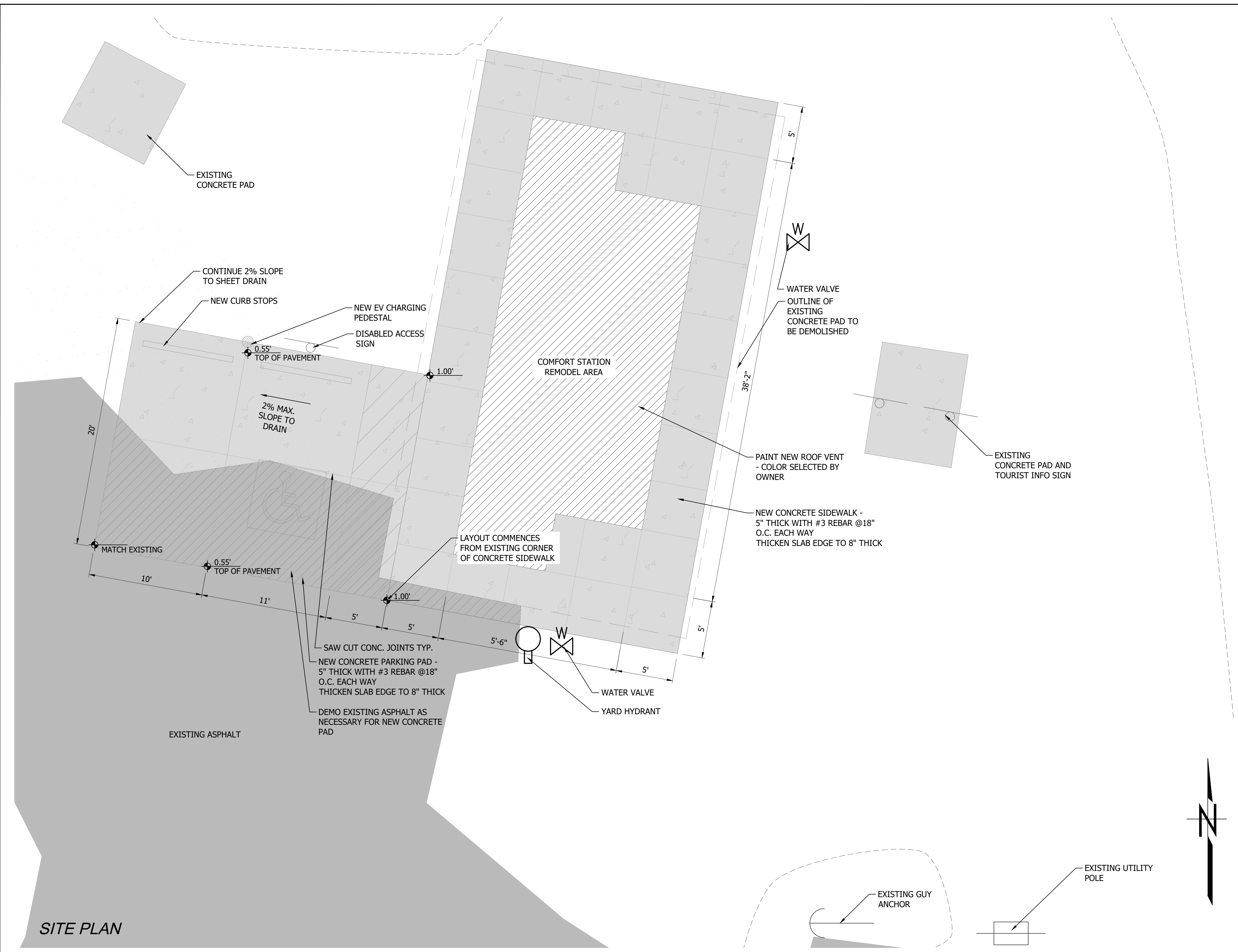

CAD NO. 23010

09/20/23 DATE

APP.

INT.

REVISIONS	
NO.	

NO.

ACTION	BY	DATE
DESIGNED	NW	04-26-23
DRAWN	IL	04-26-23
CHECKED (FIELD)	XX	XX/XX/XX
CHECKED (HDQTS.)	XX	XX/XX/XX



WASHINGTON STATE PARKS AND RECREATION COMMISSION

LEWIS & CLARK TRAIL STATE PARK

COMFORT STATION RENOVATION

ARCHITECTURAL SITE PLAN

SHEET 2 OF 17

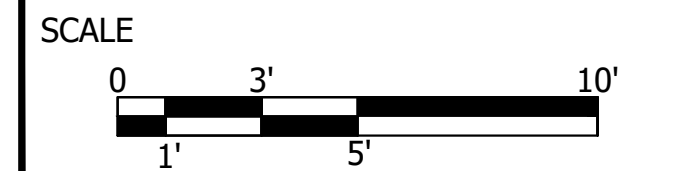

PARKS FILE#

SITE PLAN

**DEMOLITION KEY NOTES:**

1. PROTECT ALL REMAINING EQUIPMENT DURING CONSTRUCTION.

**DEMOLITION KEY NOTES:**

- ① DEMOLISH EXISTING FURNACE
- ② DEMOLISH EXISTING SLAB
- ③ DEMOLISH EXISTING JANITOR SINK
- ④ DEMOLISH EXISTING CEILING AS REQUIRED FOR NEW ASSEMBLY IN NEW BATHROOM

**LEGEND:**

▨ SLAB AREA TO BE DEMOLISHED

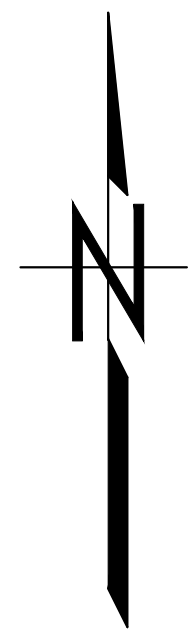
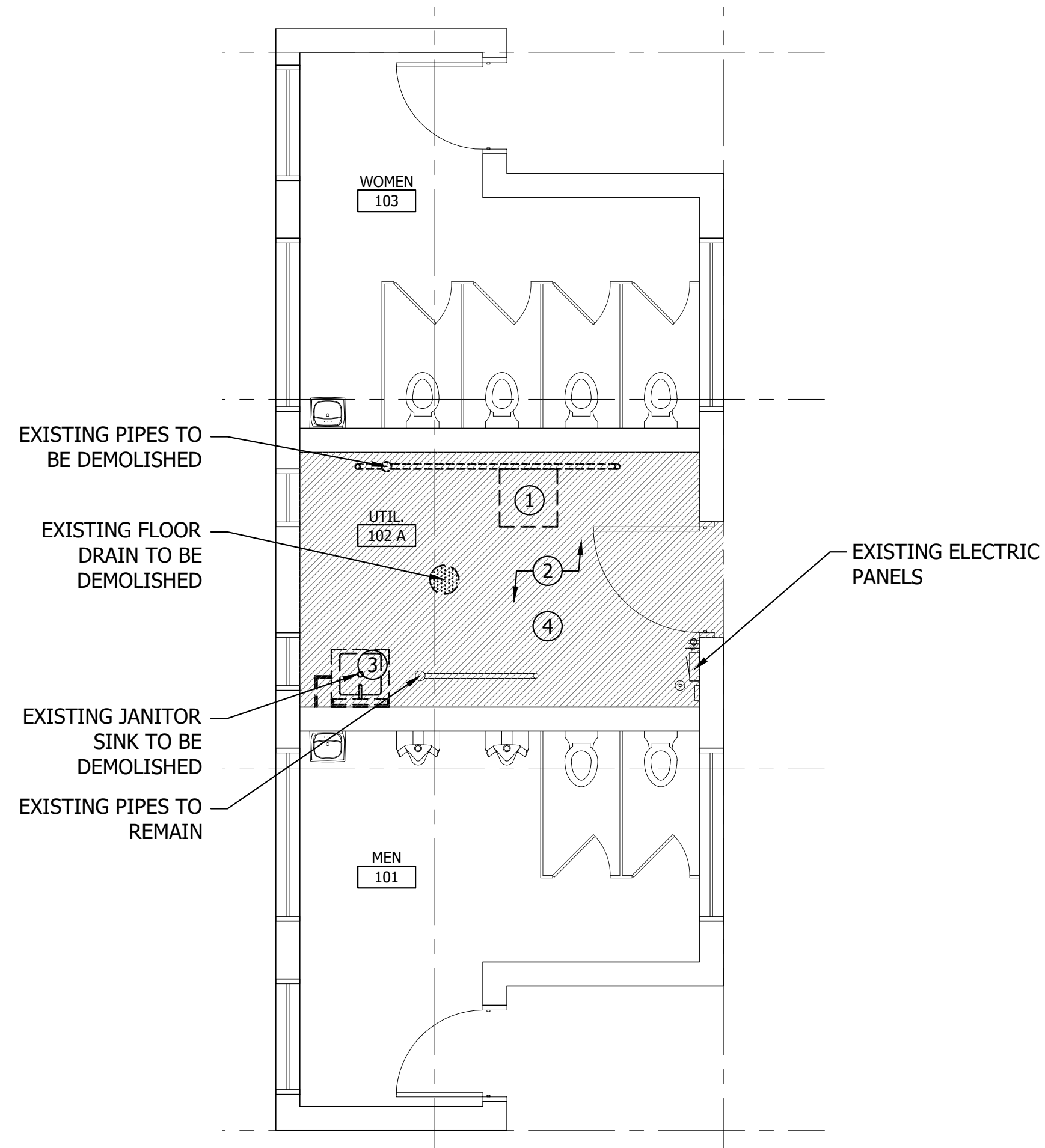

DEMO PLAN

**FLOOR PLAN NOTES:**

SEE SHEET 6 FOR WALL TYPES AND ASSEMBLY

**LEGEND:**

- UTIL 105 ROOM TAG
- ②/④ DETAIL
- ▨ NEW SLAB AREA - PROVIDE CORRECT DRAINAGE FOR EACH ROOM

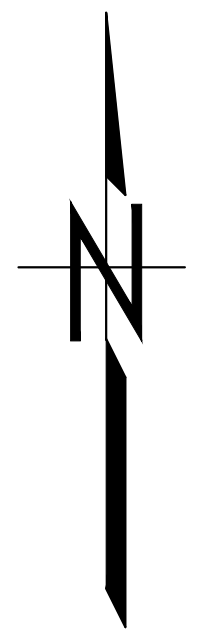
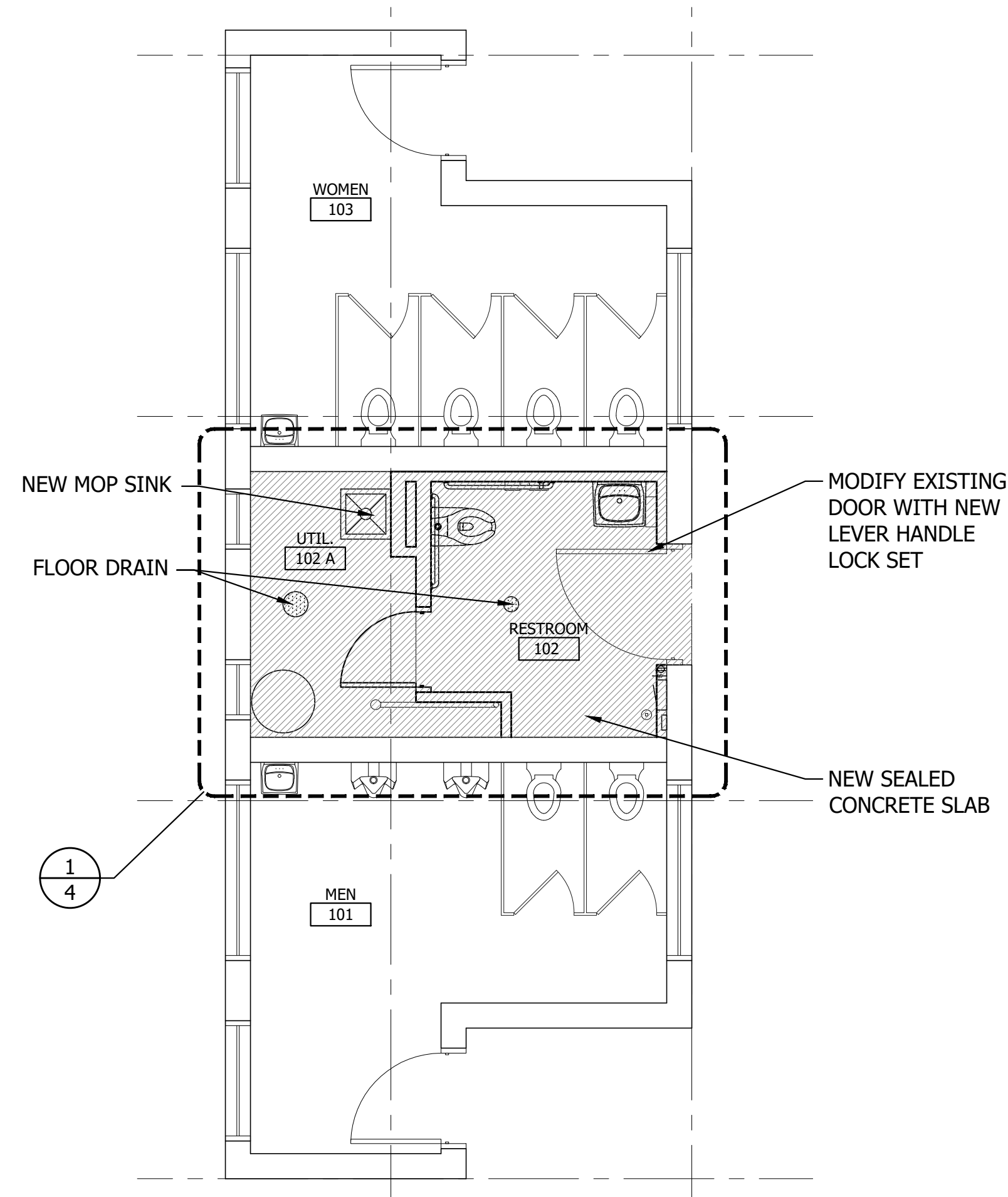

FLOOR PLAN

**REFLECTED CEILING PLAN NOTES:**

SEE SHEET 6 FOR CEILING ASSEMBLY

**LEGEND:**

- ▨ GYPSUM BOARD CEILING
- ⊕ 8'-0" CEILING HEIGHT

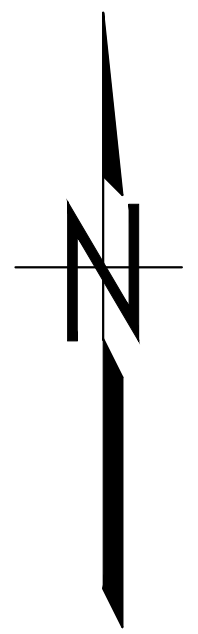
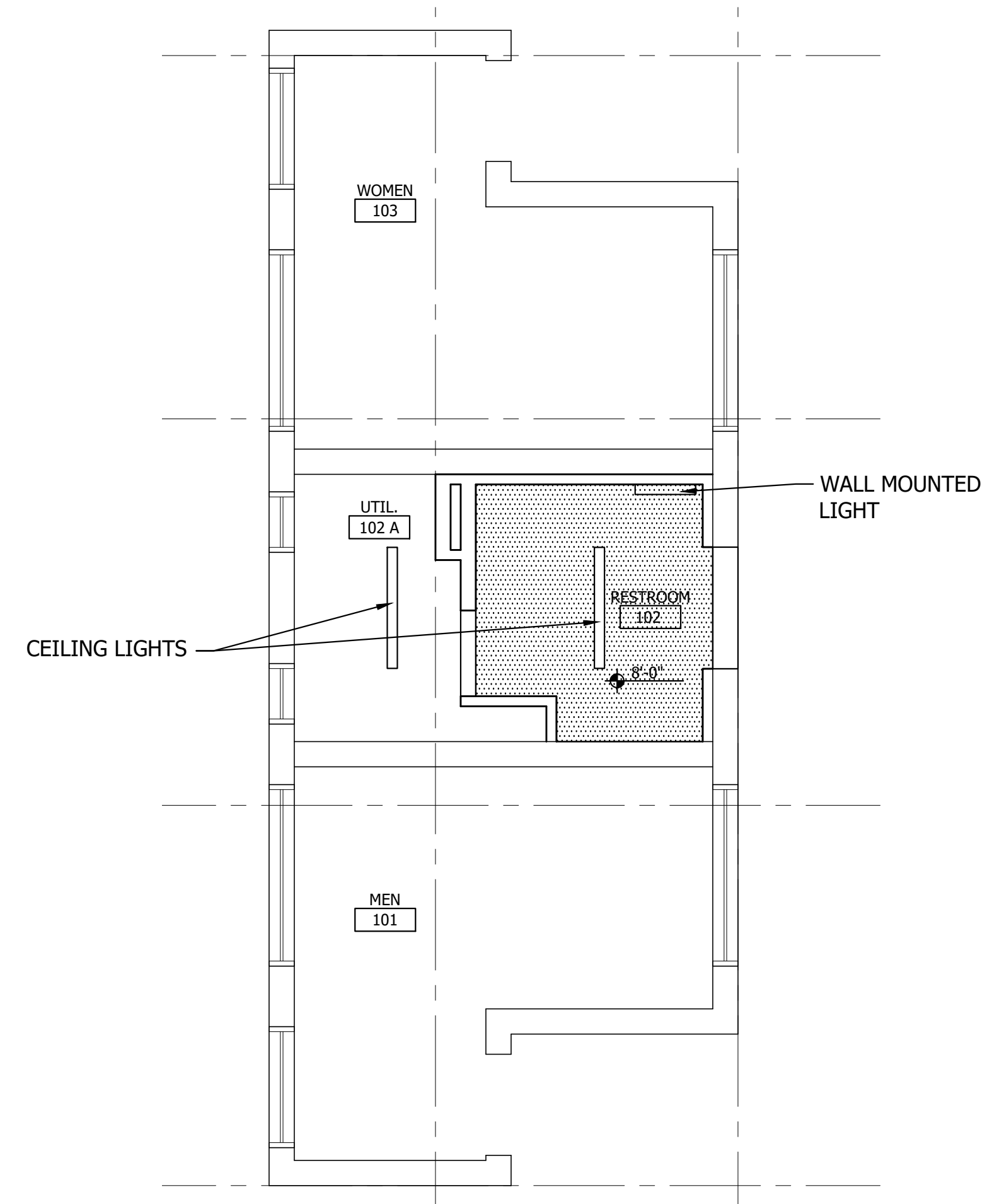

REFLECTED CEILING PLAN

CAD NO. 23010

09/20/23

DATE

APP.

INT.

REVISIONS

NO.

ACTION	BY	DATE
DESIGNED	NW	04-26-23
DRAWN	IL	04-26-23
CHECKED (FIELD)	XX	XX/XX/XX
CHECKED (HDQTS.)	XX	XX/XX/XX



WASHINGTON STATE PARKS AND RECREATION COMMISSION



LEWIS & CLARK TRAIL STATE PARK

COMFORT STATION RENOVATION

DEMO PLAN FLOOR PLAN REFLECTED CEILING PLAN

SHEET 3 OF 17



PARKS FILE#

**ENLARGED PLAN NOTES:**

SEE SHEET 6 FOR WALL TYPES AND ASSEMBLY

**LEGEND:**

1/5 INTERIOR ELEVATION

1 DOOR NUMBER

1.2F61 WALL TYPE

UTIL 105 ROOM TAG

3 DISABLE ACCESSIBLE RESTROOM SIGNAGE - SEE PAGE 6 FOR DETAILS

NEW SLAB AREA - PROVIDE CORRECT DRAINAGE FOR EACH ROOM

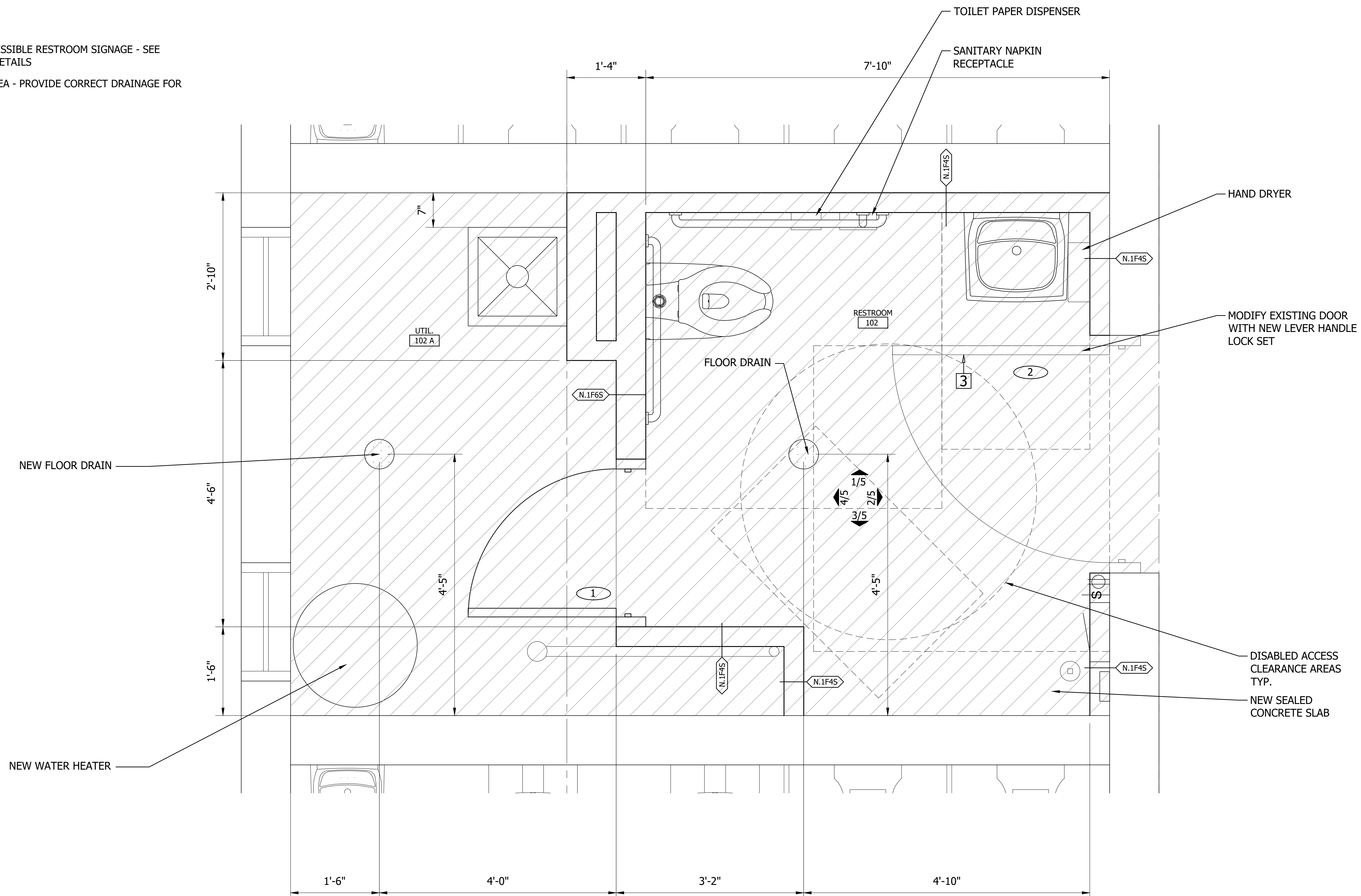

CAD NO. 23010

09/20/23

DATE

APP.

INT.

REVISIONS

NO.

ACTION	BY	DATE
DESIGNED	NW	04-26-23
DRAWN	IL	04-26-23
CHECKED (FIELD)	XX	XX/XX/XX
CHECKED (HDQTS.)	XX	XX/XX/XX



WASHINGTON STATE PARKS AND RECREATION COMMISSION



LEWIS & CLARK TRAIL STATE PARK

COMFORT STATION RENOVATION

ENLARGED FLOOR PLAN

SHEET 4 OF 17

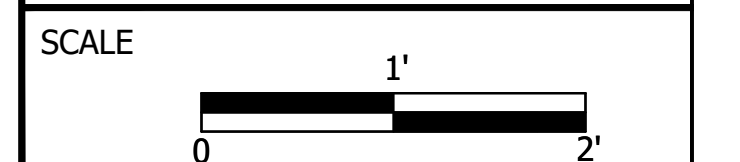

PARKS FILE#

ENLARGED FLOOR PLAN



**DOOR SCHEDULE**

MARK	DOOR				FRAME			ASSEM. RATING	HW GROUP
	SIZE	TYPE	MATERIAL	FINISH	TYPE	MATERIAL	FINISH		
01	2'6"X7'0"	F	HM	FF	01	HM	PT	-	02
02	EXIST.	EXIST.	EXIST.	EXIST.	EXIST.	EXIST.	EXIST.	EXIST.	01

**DOOR TYPES**

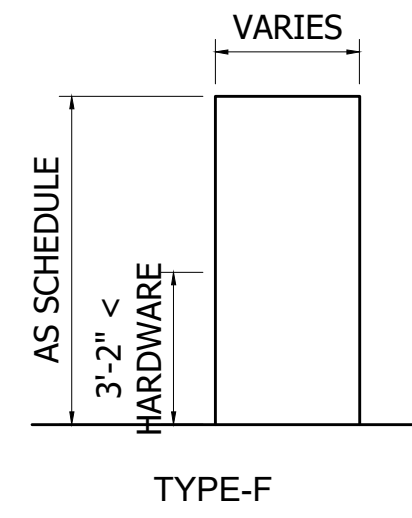

**DOOR FRAME TYPES**

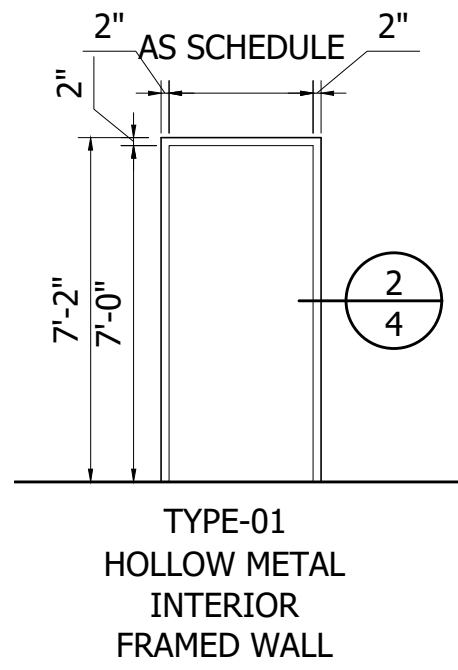

**FINISH SCHEDULE**

	FLOOR FINISH	BASE MATL	NORTH WALL		EAST WALL		SOUTH WALL		WEST WALL		CEILING	
			MATL	FINISH	MATL	FINISH	MATL	FINISH	MATL	FINISH	MATL	FINISH
102	CONC	CT	GB	PT/CT	GB	PT/CT	GB	PT/CT	GB	PT/CT	GB	PT
102A	CONC.	EXIST.	EXIST.	EXIST.	GB.	PT	EXIST.	EXIST.	EXIST.	EXIST.	EXIST.	EXIST.

**ABBREVIATION KEY**

CT	CERAMIC TILE
CONC	SEALED CONCRETE
FF	FACTORY FINISH
GB	GYPSUM BOARD
HM	HOLLOW METAL
PLAM	PLASTIC LAMINATE
PT	PAINT

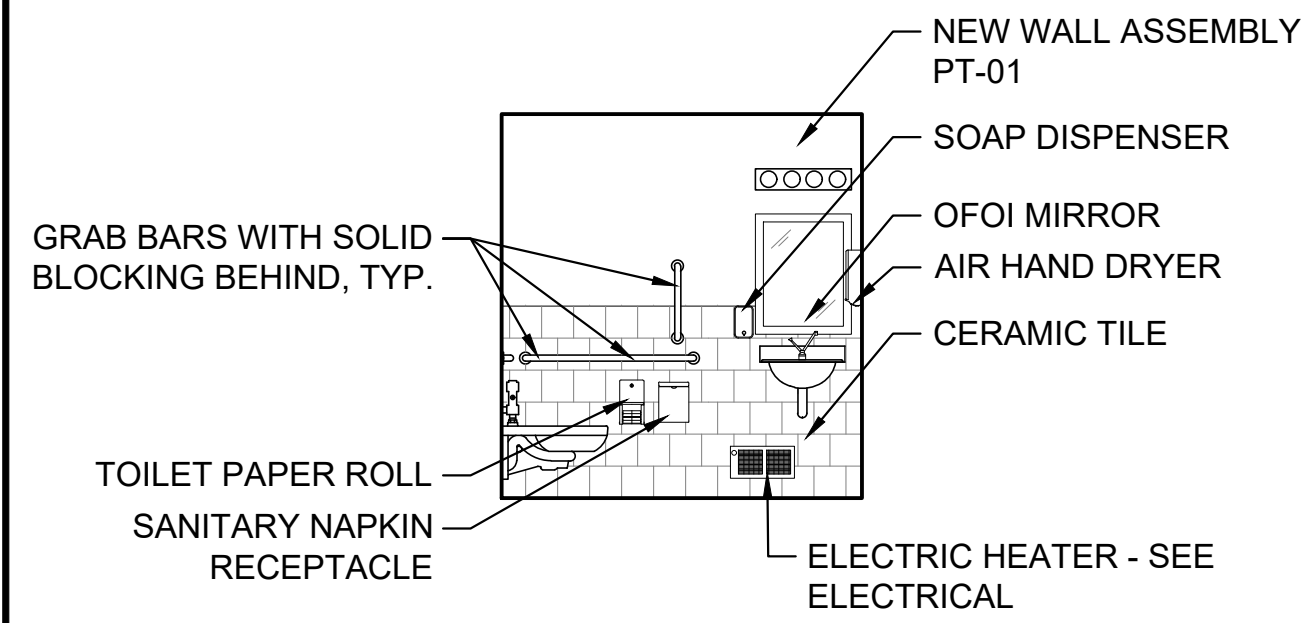

1/5 INTERIOR ELEVATION

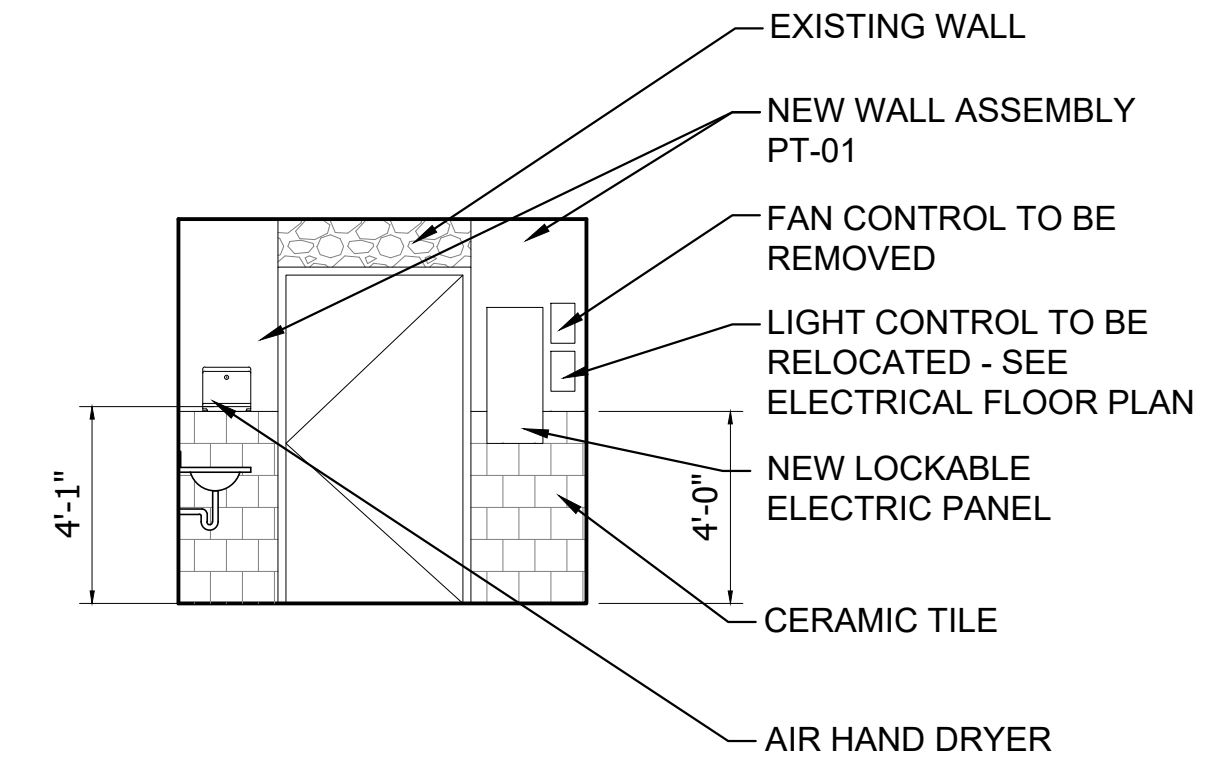

2/5 INTERIOR ELEVATION

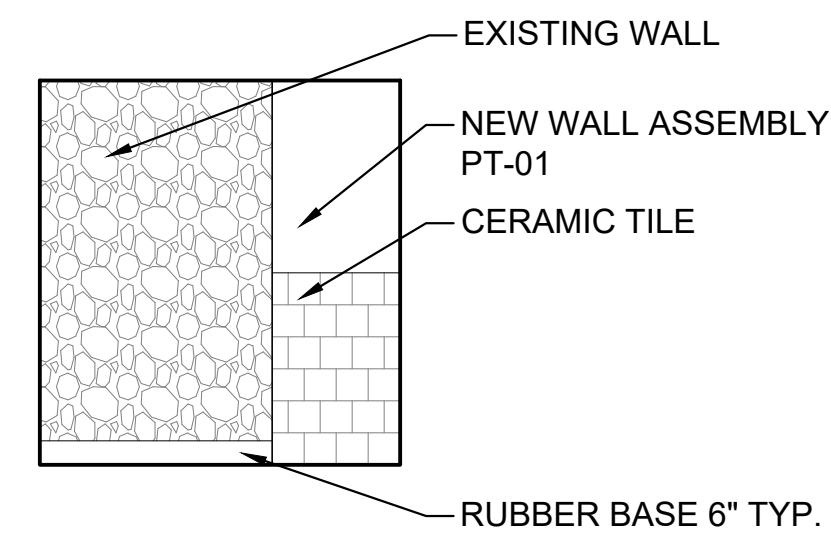

3/5 INTERIOR ELEVATION

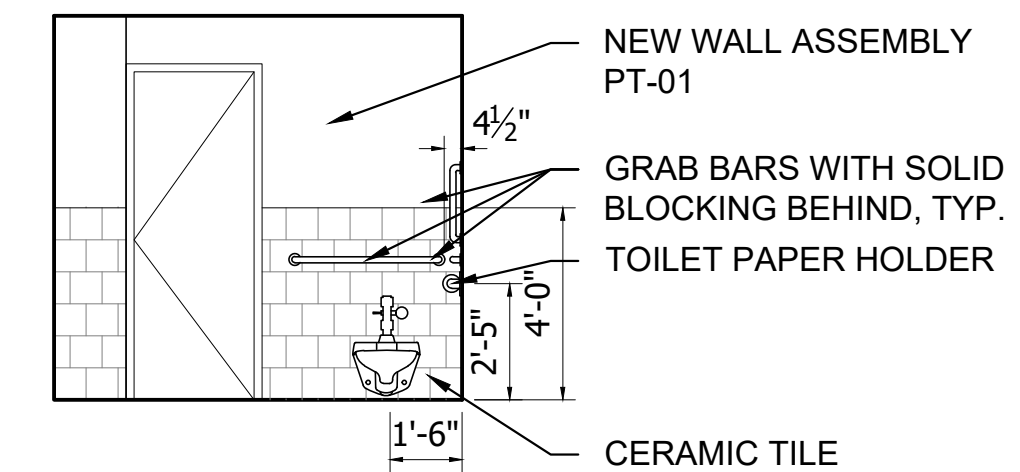

4/5 INTERIOR ELEVATION

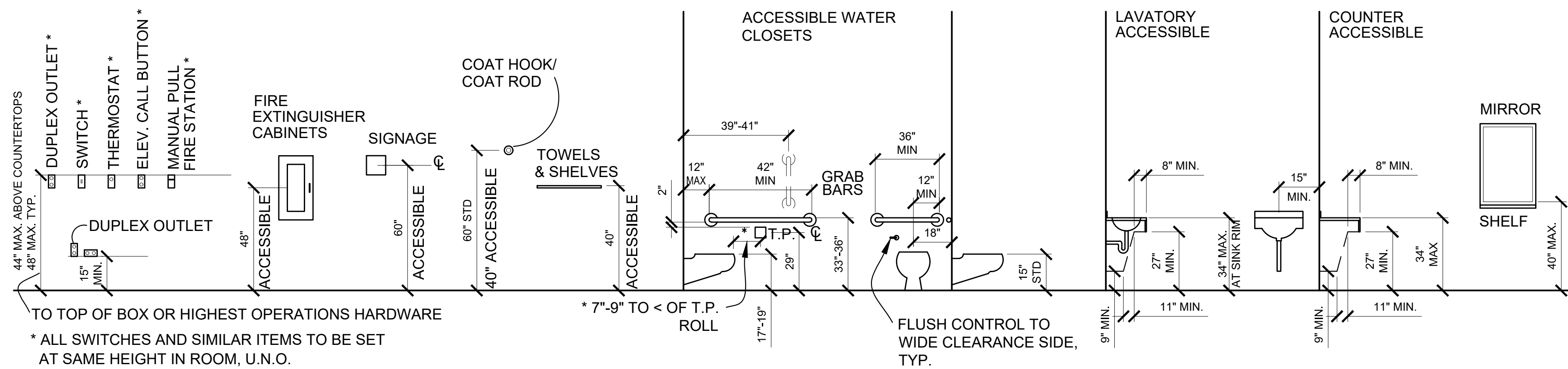

**DISABLE ACCESSIBLE MOUNTING HEIGHTS**

CAD NO. 23010

09/20/23

DATE

APP.

INT.

REVISIONS

NO.

ACTION	BY	DATE
DESIGNED	NW	04-17-23
DRAWN	IL	04-26-23
CHECKED (FIELD)	XX	XX/XX/XX
CHECKED (HDQTS.)	XX	XX/XX/XX



PROJECT ARCHITECT

**WASHINGTON STATE PARKS AND RECREATION COMMISSION**



**LEWIS & CLARK TRAIL STATE PARK**

**COMFORT STATION RENOVATION**

**INTERIOR ELEVATIONS ROOM SCHEDULE DISABLE ACCESSIBLE MOUNTING HEIGHTS**

SHEET 5 OF 17

SCALE

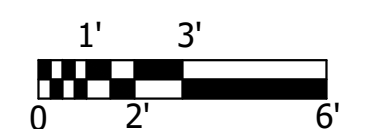

PARKS FILE#

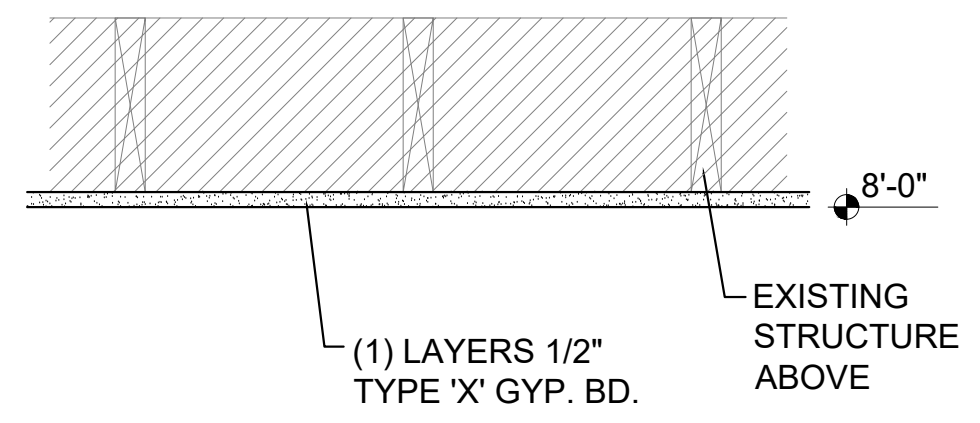

**1 CEILING**  
SCALE: 1 1/2" = 1'-0"

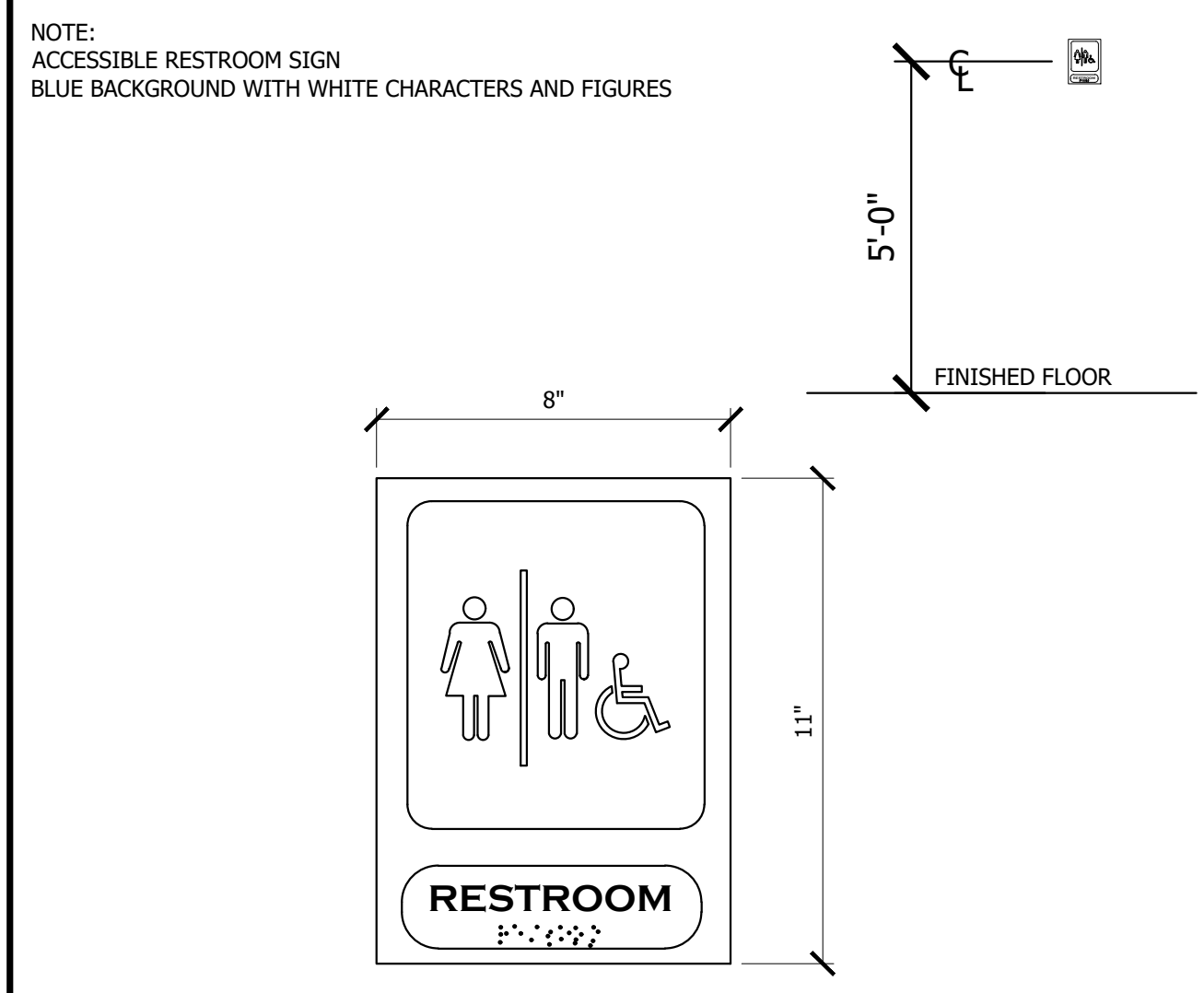

**3 DISABLED ACCESSIBLE SIGN**  
SCALE: 3" = 1'-0"

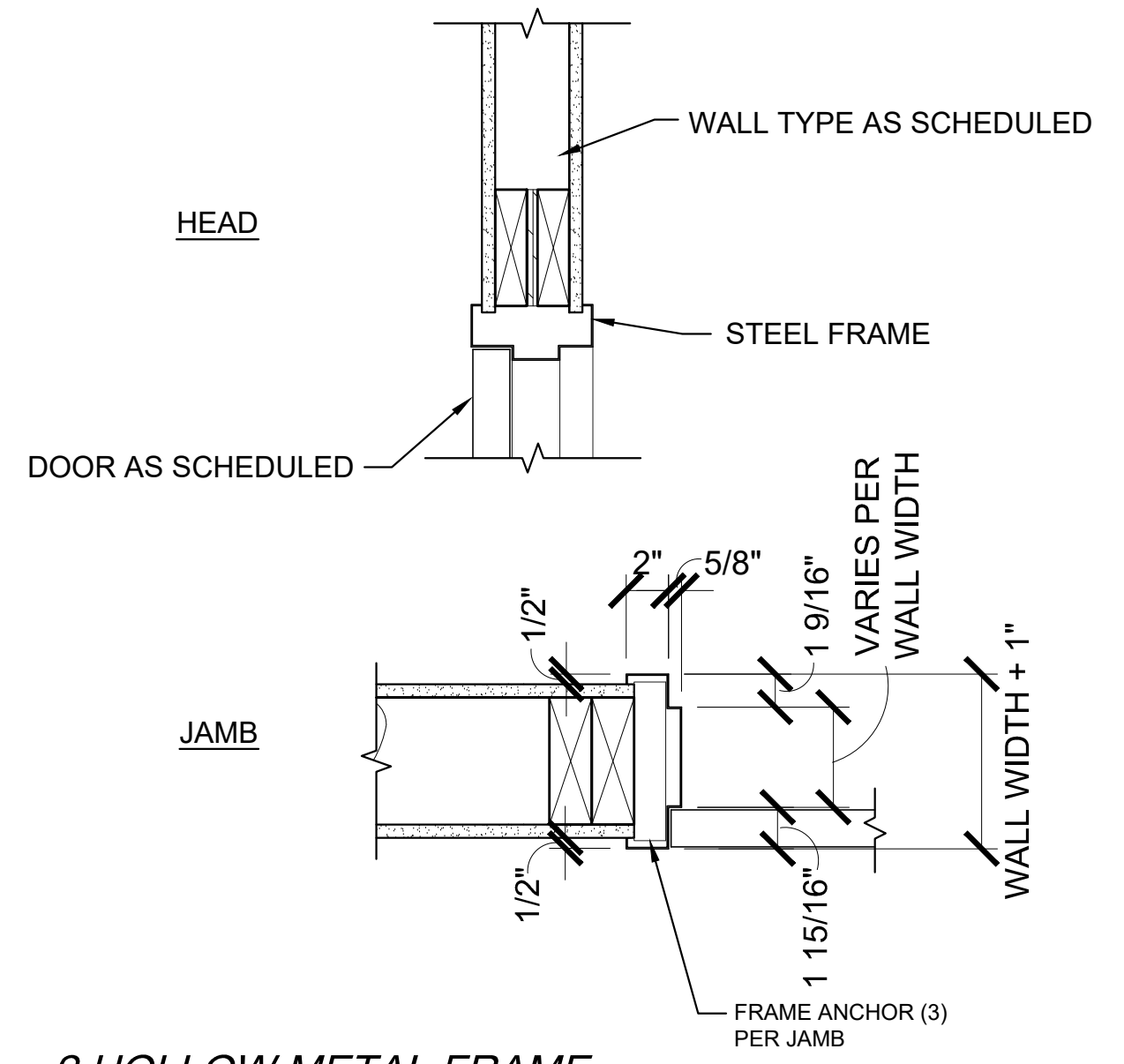

**2 HOLLOW METAL FRAME**  
SCALE: 1 1/2" = 1'-0"

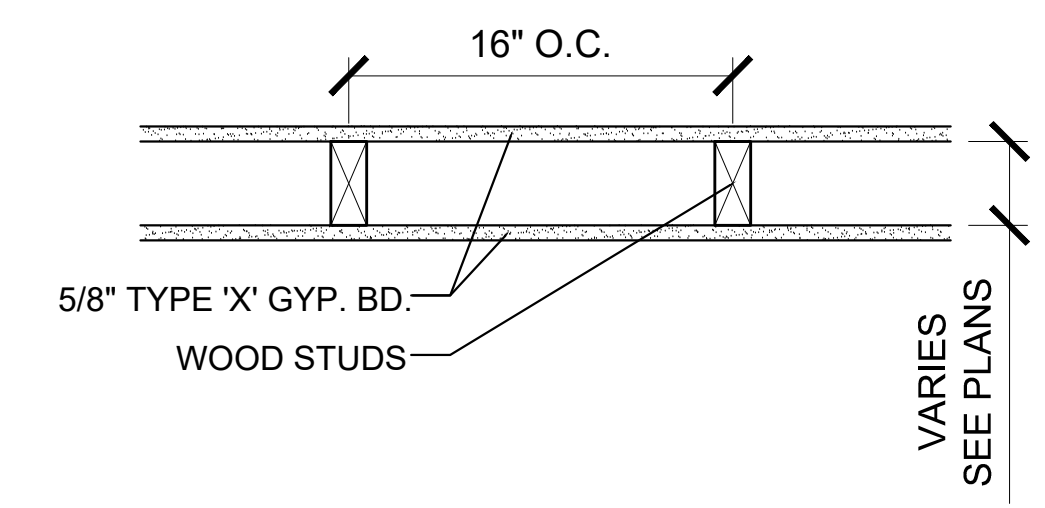

**N.1 TYPICAL INTERIOR WALL ASSEMBLY**  
SCALE: 1 1/2" = 1'-0"

**FIREBLOCKING CONSTRUCTION:** (IBC SEC. 717)  
FIREBLOCKING SHALL BE (1) 2" NOM. LUMBER OR (2) LAYERS 1" NOM. LUMBER W/ BROKEN LAP JOINTS OR (1) LAYER OF 0.719 INCH WOOD STRUCTURAL PANELS OR (1) 0.75 INCH PARTICLEBOARD W/ JTS BACKED W/ 0.75 INCH PARTICLEBOARD. FIREBLOCKS MAY ALSO BE GWB, CEMENT BD., MINERAL FIBER, GLASS FIBER OR OTHER APPROVED MATERIALS SECURELY FASTENED IN PLACE. FIRESTOP WALLS HAVING PARALLEL OF STAGGERED STUDS (FOR SOUND TRANSMISSION CONTROL) W/ MINERAL FIBER, GLASS FIBER OR OTHER APPROVED NON-RIGID MATERIAL.

PARTITION RATING	
N	NON RATED
1	1 HOUR
2	2 HOUR
3	3 HOUR
4	4 HOUR

**N.1F4S**

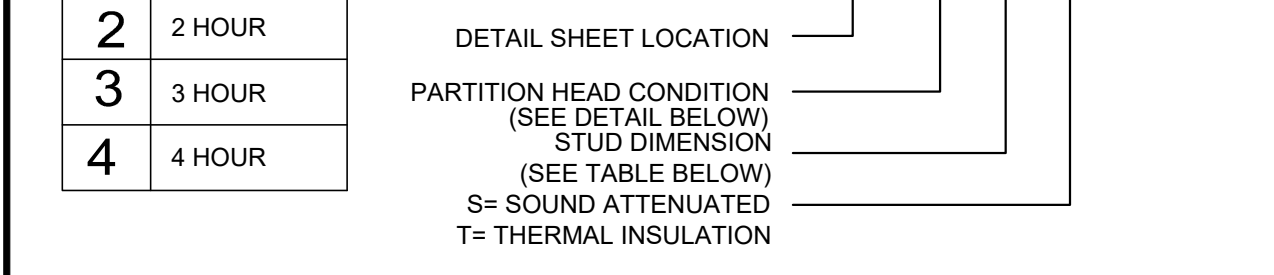

**NOTE:**  
SOUND ATTENUATED CONDITION DEFINED BY "S" REQUIRES ACOUSTICAL INSULATION IN ALL WALL VOIDS & ACOUSTICAL SEALANT AT TOP/BOTTOM & EDGES OF WALL CONSTRUCTION AND PER GA-600-2006 FIRE RESIST. DESIGN MANUAL, SECTION III.

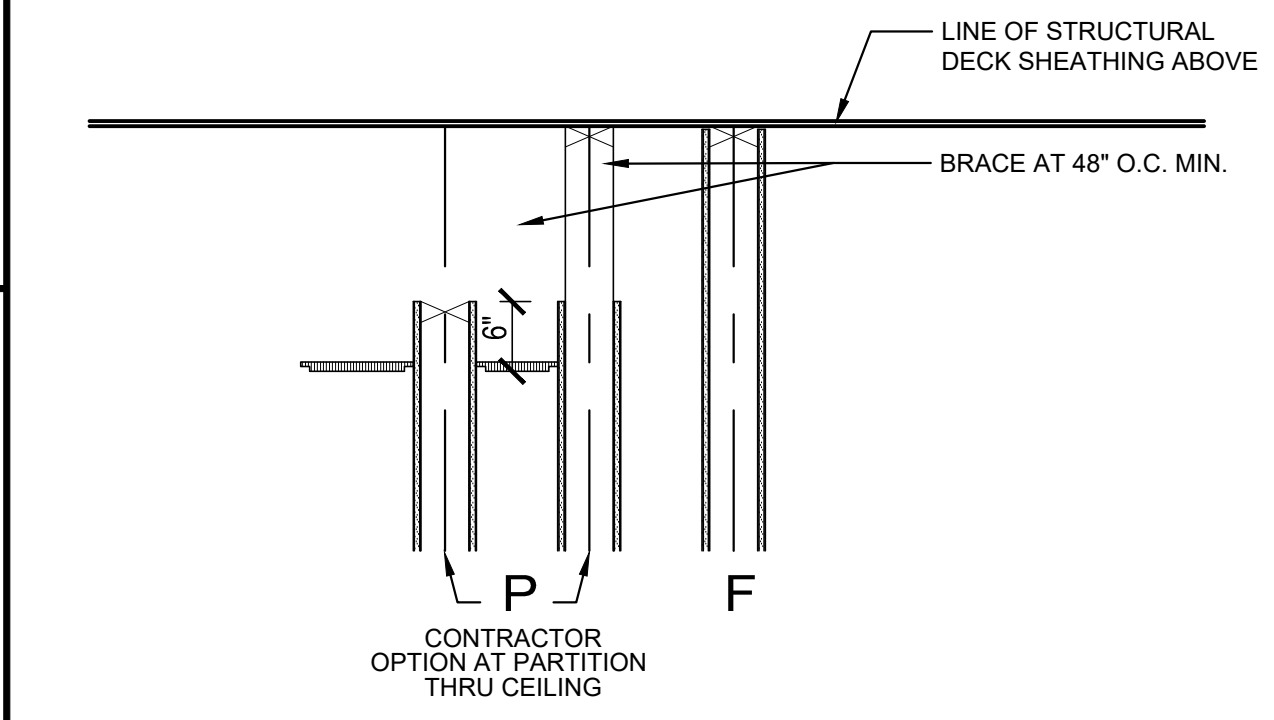

	STUD DIMENSION	CMU NOM. DIM.	ACOUSTIC INSUL.	THERMAL INSUL.
0	-		N.A.	N.A.
1	3/4" WOOD		1" UNO.	1" UNO.
2	1 1/2" WOOD		2 1/2" UNO.	2 1/2" UNO.
4	3 1/2" WOOD	4"	3.5" UNO.	3 1/2" R11 UNO.
6	5 1/2" WOOD	6"	5.5" UNO.	5 1/2" R21 UNO.
8	7 1/4" WOOD	8"	5.5" UNO.	5 1/2" R21 UNO.
10	9 1/4" WOOD	10"	5.5" UNO.	5 1/2" R21 UNO.
12	11 1/4" WOOD	12"	5.5" UNO.	5 1/2" R21 UNO.

**PARTITION HEAD TYPES**  
SCALE: FULL SIZE PARTITION ASSEMBLY HEAD TYPES

CAD NO. 23010

09/20/23 DATE

APP.

INT.

REVISIONS		
NO.	DESCRIPTION	DATE

ACTION	BY	DATE
DESIGNED	NW	04-17-23
DRAWN	IL	04-26-23
CHECKED (FIELD)	XX	XX/XX/XX
CHECKED (HDQTS.)	XX	XX/XX/XX



**WASHINGTON STATE PARKS AND RECREATION COMMISSION**

**LEWIS & CLARK TRAIL STATE PARK**

**COMFORT STATION RENOVATION**

**DETAILS**

SHEET 6 OF 17

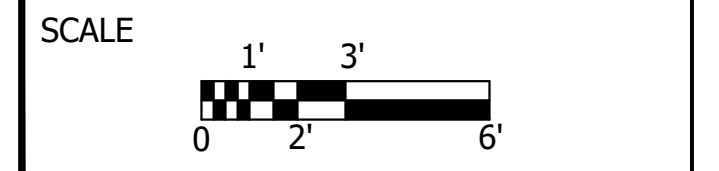

PARKS FILE#

EXHAUST FAN SCHEDULE												
#	MFR	MODEL	TYPE	CFM	DRIVE	ESP (")	RPM	INLET SONES	WEIGHT (LBS)	MOTOR		NOTES
										V/PH	HP	
EF-1	COOK	100SQN15D	INLINE	550	DIRECT	0.5	1677	6.8	50	120/1	1/8	①

NOTES:  
 ① FEATURES, OPTIONS AND ACCESSORIES SHALL INCLUDES:  
 - DISCONNECTS PROVIDED BY DIV 26.  
 - EC MOTOR WITH MANUAL SPEED ADJUSTMENT DIAL ON MOTOR.  
 - FACTORY MOUNTING BRACKET.  
 - 120V MOTORIZED BACKDRAFT DAMPER

AIR OUTLETS SCHEDULE												
#	MFR	MODEL	SERVICE	TYPE	MATERIAL	PATTERN	FINISH	BLADE			NOTES	
								SPC (")	POS	DEFL (")		
1	PRICE	96	HEAVY DUTY RETURN	GRILLE	ALUMINUM	FIXED	ALUM.	3/4	ANGLED DOWN	45	①②③	

NOTES:  
 ① PAINT THE INSIDE SURFACE OF THE DUCT CONNECTION FLAT BLACK, UNLESS OTHERWISE PROVIDED WITH DUCT LINER.  
 ② PROVIDE BALANCING DAMPER IN BRANCH DUCT SERVING AIR OUTLET AT TAKEOFF FROM TRUNK DUCT.  
 ③ PROVIDE TRANSITION FROM AIR OUTLET NECK TO BRANCH DUCT AS REQUIRED.

ELECTRIC WALL HEATER SCHEDULE									
#	MFR	MODEL	MOUNTING	CFM	ΔT (°F)	ELECTRICAL		NOTES	
						V/PH	WATTS		
EH-1	INDEECO	WRI	RECESSED WALL	40	60	240/1	750	①	
EH-2	INDEECO	WRI	RECESSED WALL	40	60	240/1	750	①	
EH-3	INDEECO	CLI	RECESSED CEILING	80	50	240/1	1250	①	
EH-4	INDEECO	CLI	RECESSED CEILING	80	50	240/1	1250	①	
EH-5	INDEECO	CLI	RECESSED CEILING	80	50	240/1	1250	①	
EH-6	INDEECO	CLI	RECESSED CEILING	80	50	240/1	1250	①	

NOTES:  
 ① FEATURES, OPTIONS AND ACCESSORIES SHALL INCLUDE:  
 - INTEGRAL TAMPER-PROOF THERMOSTAT  
 - PROVIDE WITH WALL BOX FOR RECESSED MOUNTING AND FACTORY DISCONNECT.  
 - CONFIRM COLOR SELECTION WITH ARCHITECT

ROOF HOOD SCHEDULE							
#	MFR	MODEL	SERVICE	SIZE (W"xH")	CFM	MAX S.P. (° WC)	NOTES
RH-1	GREENHECK	GRSR	EF-1 EXHAUST	10X10	550	0.10	①

NOTES:  
 ① FEATURES, OPTIONS AND ACCESSORIES SHALL INCLUDE:  
 - ALUMINUM INSECT SCREEN.  
 - PRE-FABRICATED ROOF CURB FOR PITCHED SHINGLES ROOF APPLICATION  
 - SEE ARCHITECTURAL ELEVATIONS FOR MOUNTING LOCATION.

### GENERAL NOTES

- THE MECHANICAL SYSTEMS SHALL CONSIST OF ALL WORK SHOWN ON THE MECHANICAL DRAWINGS, DIAGRAMS AND AS DESCRIBED IN ASSOCIATED TECHNICAL SPECIFICATIONS.
- REFER TO SPECIFICATIONS AND ALL OTHER DIVISION DOCUMENTS FOR ADDITIONAL REQUIREMENTS. COORDINATE WORK SHOWN ON THE DRAWINGS WITH THE SPECIFICATIONS. IN CASE OF DISCREPANCY BETWEEN SPECIFICATIONS AND DRAWINGS REFER TO THE GENERAL CONDITIONS AND NOTIFY THE A/E FOR DIRECTION.
- MECHANICAL CONTRACTOR SHALL COORDINATE WORK WITH ALL OTHER TRADES.
- MODEL NUMBERS OF EQUIPMENT SHOWN ON THE SCHEDULES AND THROUGHOUT THE DRAWINGS AND SPECIFICATIONS SHALL NOT BE CONSIDERED COMPLETE AND MATERIAL SHALL NOT BE ORDERED BY MFR/MODEL ALONE. REVIEW THE COMPLETE DESCRIPTION, LOCATION AND ARRANGEMENT ON THE DRAWINGS, NOTES AND SPECIFICATIONS TO DETERMINE THE EXACT MATERIAL, CONFIGURATION AND ACCESSORIES TO BE ORDERED. THE MANUFACTURERS LISTED ARE THE BASIS OF DESIGN.
- HVAC SYSTEMS SHALL BE BALANCED IN ACCORDANCE WITH THE 2018 WA STATE ENERGY CODE, THE PROJECT SPECIFICATIONS AND GENERALLY ACCEPTED ENGINEERING STANDARDS TO ENSURE AT A MINIMUM THAT AIR AND WATER FLOW RATES ARE MEASURED AND ADJUSTED TO DELIVER THE DESIGN RATES WITHIN SPECIFIED TOLERANCES.
- THE MECHANICAL PLANS ARE DIAGRAMMATIC IN NATURE AND DO NOT ATTEMPT TO SHOW ALL REQUIRED OFFSETS AND FITTINGS. PROVIDE ALL NECESSARY OFFSETS, TRANSITIONS AND FITTINGS REQUIRED FOR A COMPLETE SYSTEM. REFER TO ARCHITECTURAL, STRUCTURAL, PLUMBING AND ELECTRICAL DRAWINGS FOR COORDINATION PURPOSES TO AVOID CONFLICTS.
- INSTALL ALL MECHANICAL WORK AS HIGH AS POSSIBLE, TIGHT TO STRUCTURE ABOVE, UNLESS NOTED OTHERWISE. IN GENERAL IT IS THE INTENT THAT ALL MECHANICAL SYSTEMS BE CONCEALED ABOVE CEILINGS OR INSIDE WALLS AND SHAFTS.
- COORDINATE ALL EXPOSED MECHANICAL SYSTEMS, PIPING AND DUCTWORK SO THAT LOCATIONS AND ROUTING ARE INTEGRATED WITH THE OTHER BUILDING ELEMENTS (WALLS, ROOFS, JOISTS, LIGHTS, ETC.). GENERALLY RUN SYSTEMS PARALLEL OR PERPENDICULAR TO BUILDING ELEMENTS AND RUN IN A MANNER TO CONCEAL OR BLEND WITH BUILDING LINES.
- PROVIDE NEC CODE MINIMUM HORIZONTAL AND VERTICAL WORKING CLEARANCES FOR ALL ELECTRICAL PANELS AND EQUIPMENT. OFFSET MECHANICAL WORK AS REQUIRED.
- COORDINATE ALL MECHANICAL WORK WITH THAT OF OTHER TRADES TO ENSURE PROPER INTERFACE, ADEQUATE CLEARANCES, AND TO AVOID CONFLICTS. PROVIDE FIELD COORDINATION AND/OR DRAWINGS PRIOR TO FABRICATION AND/OR INSTALLATION. CONFLICTS AND INTERFERENCES THAT COULD HAVE BEEN AVOIDED BY PROPER PRE-PLANNING AND COORDINATION SHALL BE REMOVED AND CORRECTED AT NO COST TO THE OWNER.
- FIELD LOCATE ALL ROOF, FLOOR AND WALL PENETRATIONS AND ADJUST TO AVOID CONFLICT WITH STRUCTURAL ELEMENTS, BEAMS, CROSS-BRACING, ARCHITECTURAL ELEMENTS. THE MECHANICAL CONTRACTOR IS RESPONSIBLE FOR LOCATING AND COORDINATING ALL SAW CUTTING AND DRILLING REQUIRED FOR MECHANICAL SYSTEM OPENINGS.
- HANGERS, SUPPORTS AND ANCHORS FOR MECHANICAL SYSTEMS AND EQUIPMENT ARE NOT NECESSARILY DESIGNED OR SHOWN ON THE DRAWINGS. THE CONTRACTOR SHALL PROVIDE ALL NECESSARY SUPPORT MEMBERS, HANGERS, BRACKETS, HARDWARE, CLEVIS HANGERS, RODS, ETC. TO SECURELY HANG, BRACE AND SUPPORT MECHANICAL SYSTEMS, DUCTWORK, PIPING, EQUIPMENT AND OTHER DEVICES. ANCHOR SUPPORTS TO BUILDING STRUCTURE OR OTHER APPROPRIATE BUILDING ELEMENTS. SEE TYPICAL MECHANICAL DETAILS, ARCHITECTURAL AND STRUCTURAL DRAWINGS FOR ADDITIONAL INFORMATION, LIMITATIONS AND DETAILS.
- ROOF CURBS: ROOF CURBS SHALL BE MOUNTED PLUMB AND LEVEL ON PITCHED ROOFS. PROVIDE FACTORY CURBS WITH CORRECT SLOPE OR PROVIDE FIELD INSTALLED BLOCKING AND SHIMS BELOW CURB. ALL WOOD PRODUCTS SHALL BE PRESSURE TREATED LUMBER.
- COORDINATE THE FURNISHING AND INSTALLATION OF ALL ELECTRICAL DISCONNECT SWITCHES, STARTERS, VFDS, ETC., IN ORDER TO ASSURE THAT ALL ENERGIZED MECHANICAL IS PROVIDED WITH THE REQUIRED CIRCUIT PROTECTION METHODS AND CONTROL DEVICES. WHERE DRAWINGS NOTES, SCHEDULES AND EQUIPMENT SPECIFICATIONS ARE SILENT OR UNCLEAR AS TO WHICH DIVISION (22-PLBG, 23-HVAC, OR 26-ELECTRICAL) IS TO PROVIDE THESE DEVICES, THE CONTRACTOR SHALL CONTACT THE ENGINEER, PRIOR TO BID, FOR DIRECTION.
- VOLUME DAMPERS ARE NOT SHOWN FOR CLARITY. PROVIDE A DAMPER FOR EACH SUPPLY, RETURN AND EXHAUST OPENING AND IN BRANCHES WHERE THREE OR MORE OPENINGS ARE ASSOCIATED WITH THE BRANCH AND ELSEWHERE AS NOTED ON THE DRAWINGS OR SPECIFICATIONS.
- PROVIDE CONCEALED DAMPER REGULATORS FOR ALL VOLUME DAMPERS OVER INACCESSIBLE CEILINGS AND SOFFITS. REFER TO ARCHITECTURAL DRAWINGS FOR CEILING TYPES.
- PROVIDE DIFFUSER AND GRILLE FRAMES COMPATIBLE WITH ARCHITECTURAL CEILING TYPE. REFER TO ARCHITECTURAL REFLECTED CEILING PLANS FOR CEILING TYPE.
- ALL DUCTWORK SIZES SHOWN ARE OUTSIDE DIMENSIONS, UNLESS SPECIFICALLY NOTED ON PLANS. DUCT LINER HAS BEEN ACCOUNTED FOR ON LINED DUCT. ADDITIONAL CLEARANCE WILL NEED TO BE ACCOUNTED FOR FOR EXTERNALLY INSULATED DUCT.
- TURNING VANES: ALL RECTANGULAR DUCT ELBOWS SHALL BE PROVIDED WITH TURNING VANES, WHETHER OR NOT SPECIFICALLY SHOWN ON THE DUCTWORK DRAWING PLANS AND SECTIONS.
- PROVIDE TRANSITIONS AS REQUIRED TO TO CONNECT DUCTWORK TO TERMINAL UNITS, FANS, AIR HANDLERS CONNECTIONS, ETC.
- PROVIDE FLEXIBLE DUCT FITTINGS ON CONNECTIONS TO ALL ENERGIZED AIR MOVING EQUIPMENT (FANS, AIR HANDLERS, ETC.).

### MECHANICAL ABBREVIATIONS

AAV	AUTOMATIC AIR VENT	HW	HOT WATER
ABV	ABOVE	HX	HEAT EXCHANGER
AD	ACCESS DOOR	HZ	HERTZ
AFS	AIR FLOW SWITCH	ID	INSIDE DIAMETER
AFF	ABOVE FINISHED FLOOR	INV	INVERT
AG	ABOVE GROUND	I.E.	INVERT ELEVATION
AHU	AIR HANDLING UNIT	INSUL	INSULATION
AL	ACOUSTICALLY LINED	IND	INDIRECT
ALUM	ALUMINUM	KW	KILOWATT
APD	AIR PRESSURE DROP	KWH	KILOWATT HOUR
ARCH	ARCHITECT	LAT	LEAVING AIR
AVG	AVERAGE	TEMP	TEMPERATURE
AWT	AVERAGE WATER TEMPERATURE	LBS	POUNDS
BAS	BUILDING AUTOMATION SYSTEM	LDB	LEAVING DRY BULB
BDD	BACKDRAFT DAMPER	LF	LINEAR FOOT
BFF	BELOW FINISHED FLOOR	LWT	LEAVING WATER
BFP	BACKFLOW PREVENTER	LG	LONG OR LENGTH
BG	BELOW GROUND	L/P	LEAVING WATER TEMPERATURE
BHP	BRAKE HORSEPOWER	LWB	LEAVING WET BULB
BLDG	BUILDING	LWG	LEAVING WATER TEMPERATURE
BLDG	BUILDING	LWT	LEAVING WATER TEMPERATURE
BP	BYPASS	LVG	LEAVING WATER TEMPERATURE
BTU	BRITISH THERMAL UNIT	MCA	MINIMUM CIRCUIT AMPACITY
BTUH	BRITISH THERMAL UNITS PER HOUR	MCOCP	MAXIMUM OVERCURRENT PROTECTION
BOD	BOTTOM OF DUCT	MBH	THOUSAND (1000) BTU PER HOUR
BOP	BOTTOM OF PIPE	MCC	MOTOR CONTROL CENTER
BSMT	BASEMENT	MFR	MANUFACTURER
BV	BALANCING VALVE	MS	MOTOR STARTER
CA	COMBUSTION	MTD	MOUNTED
CAP	CAPACITY	MTG	MOUNTING
CC	CENTER TO CENTER OR COILING COIL	NC	NORMALLY CLOSED
CD	CEILING DIFFUSER	NO	NORMALLY OPEN
CFM	CUBIC FEET PER MINUTE	MOD	MOTOR-OPERATED DAMPER
CG	CEILING GRILLE	NIC	NOT IN CONTRACT
CI	CAST IRON	NPT	NATIONAL PIPE THREAD
CLG	CEILING	OA	NOT TO SCALE
COG	CLEAN OUT TO GRADE	OD	OPPOSED BLADE DAMPER
CO	CLEAN OUT	OD	OUTSIDE DIAMETER
COMB	COMBUSTION	OSA	OUTSIDE AIR
COND	CONDENSATE OR CONDENSER	OAT	OUTSIDE AIR TEMPERATURE
CONC	CONCRETE	OF	OVERFLOW
CONST	CONSTRUCTION	OFCI	OWNER FURNISHED, CONTRACTOR
COP	COEFFICIENT OF PERFORMANCE	PD	INSTALLED PRESSURE DROP
CU	COPPER	PH	PHASE
CUH	CABINET UNIT HEATER	PIAC	PRESSURE INDEPENDENT AIR CONTROLLER
CW	COLD WATER	PLBG	PLUMBING
CU	CONDENSING UNIT	POC	POINT OF CONNECTION
CR	CONDENSATE RETURN	PRV	PRESSURE REDUCING VALVE
CL	CENTER LINE	PSI	POUNDS PER SQUARE INCH
D	DEEP OR DEPTH	PSIG	POUNDS PER SQUARE INCH GAUGE
DB	DRY BULB OR DECIBEL	PT	PRESSURE & TEMPERATURE
DBA	A-WEIGHTED DECIBELS	RA	RETURN AIR
DCV	DEMAND CONTROL VENTILATION	RAG	RETURN AIR GRILLE
DDC	DIRECT DIGITAL CONTROLS	RAT	RETURN AIR TEMPERATURE
DEMO	DEMOLITION	RD	ROOF DRAIN
DN	DOWN	RET	RETURN
DIA	DIAMETER Ø	REV	REVISION
DPS	DIFFERENTIAL PRESSURE SWITCH	RF	RETURN FAN
DP	DROP	RPM	REVOLUTIONS PER MINUTE
DPR	DAMPER	RTU	ROOF TOP UNIT
DWG	DRAWING	SA	SUPPLY AIR
(E)	EXISTING	SAT	SUPPLY AIR TEMPERATURE
EA	EACH OR EXHAUST AIR	SEER	SEASONAL ENERGY EFFICIENT RATIO
EAT	ENTERING AIR TEMPERATURE	SENS	SENSIBLE
EDB	ENTERING DRY BULB	SD	SMOKE DETECTOR OR DAMPER
EER	ENERGY EFFICIENCY RATIO	SF	SUPPLY FAN
EF	EXHAUST FAN	SFD	SMOKE-FIRE DAMPER
EFF	EFFICIENCY	SHT	SHEET
EG	EXHAUST GRILLE	SP	STATIC PRESSURE
ELEC	ELECTRIC OR ELECTRICAL	SQ	SQUARE
ELEV	ELEVATION	SQ	FT SQUARE FOOT
EMCS	ENERGY MANAGEMENT AND CONTROL SYSTEM	SS	STAINLESS STEEL
ENCL	ENCLOSURE	STD	STANDARD
ESP	EXTERNAL STATIC PRESSURE	TA	TRANSFER AIR TEMPERATURE
EST	ESTIMATE(D)	TEMP	TEMPERATURE
EWB	ENTERING WET BULB	TH	THICK OR THICKNESS
EWT	ENTERING WATER TEMPERATURE	TOD	TOP OF DUCT
EXH	EXHAUST	TOP	TOP OF PIPE
FA	FRESH AIR (OUTSIDE AIR)	TP	TRAP PRIMER
FCO	FLOOR CLEAN OUT	TYP	TYPICAL
FCU	FAN COIL UNIT	UF	UNDER FLOOR
FD	FIRE DAMPER OR FLOOR DRAIN	UG	UNDERGROUND
FDC	FIRE DEPARTMENT CONNECTION	UH	UNIT HEATER
FF	FINAL FILTER	UR	URINAL
FLA	FULL LOAD AMPS	US	UNDER SLAB
FLR	FLOOR	V	VENT OR VOLT
FOB	FLAT ON BOTTOM	VAC	VACUUM
FOT	FLAT ON TOP	VAV	VARIABLE AIR VOLUME DRIVE
FPM	FEET PER MINUTE	VEL	VELOCITY
FPI	FINS PER INCH	VFD	VARIABLE FREQUENCY DRIVE
FPS	FEET PER SECOND	VTR	VENT THRU ROOF
FP	FIRE PROTECTION	VD	VOLUME DAMPER
FS	FLOOR SINK	WB	WET BULB
FT	FEET/FOOT OR FINNED TUBE	WC	WATER CLOSET
FV	FACE VELOCITY	WCO	WALL CLEAN OUT
G	GAS (NATURAL)	WH	WATER HEATER
GA	GAUGE OR GAGE	WHA	WATER HAMMER
GAL	GALLONS	ARRESTOR	
GALV	GALVANIZED	WG	WATER GAUGE
GPM	GALLONS PER MINUTE	WPD	WATER PRESSURE DROP
GPH	GALLONS PER HOUR	WT	WEIGHT
H	HIGH OR HEIGHT		
HB	HOSE BIBB		
HC	HEATING COIL		
HD	HEAD		
HGBP	HOT GAS BYPASS		
HL	HIGH LIMIT		
HP	HORSEPOWER		
HTG	HEATING		

### HVAC SYMBOLS

	RECT. DUCT SIZE (INCHES) (FACING SIDE LISTED FIRST)
	CIRCULAR DUCT DIAMETER (INCHES)
	FLAT OVAL DUCT SIZE (INCHES)(FACING SIDE LISTED FIRST)
	ACOUSTICALLY LINED DUCT. 1" THICK UNLESS NOTED OTHERWISE. DUCT SIZE INCLUDES ALLOWANCE FOR LINER
	DUCT RISE IN DIRECTION OF ARROW
	DUCT DROP IN DIRECTION OF ARROW
	FIRE OR FIRE/SMOKE DAMPER (# INDICATES TYPE)
	TURNING VANES
	HIGH EFFICIENCY BRANCH TAP
	FLEXIBLE DUCT CONNECTOR
	VOLUME CONTROL DAMPER (SEE GENERAL NOTES)
	MOTORIZED DAMPER & ACTUATOR
	SUPPLY/OSA DUCT TURNED UP
	SUPPLY/OSA DUCT TURNED DOWN
	RETURN AIR DUCT TURNED UP
	RETURN AIR DUCT TURNED DOWN
	EXHAUST/RELIEF DUCT TURNED UP
	EXHAUST/RELIEF DUCT TURNED DOWN
	FLEXIBLE DUCT
	SIDEWALL DIFFUSER/GRILLE
	LINEAR SLOT DIFFUSER
	AIR OUTLET (SUPPLY)
	AIR INLET (RETURN/RELIEF)
	AIR INLET (EXHAUST)
	ROOF DRAIN
	LOUVER
	THERMOSTAT OR TEMPERATURE SENSOR (SUBSCRIPT A=AVERAGING, G=PROTECTIVE GUARD, C=CO2 SENSOR)

### GENERAL SYMBOLS

	SECTION IDENTIFYING NUMBER
	CROSS-SECTION SYMBOL
	DETAIL IDENTIFYING NUMBER
	DETAIL SYMBOL
	SHEET WHERE SECTION IS SHOWN
	SHEET WHERE DETAIL IS SHOWN
	POINT OF CONNECTION (POC) SYMBOL
	EQUIP. TYPE-NUMBER (SEE SCHEDULES)
	EQUIPMENT IDENTIFIER (OPTIONAL TAG STYLE)
	DIFFUSER OR REGISTER/GRILLE TAG
	CFM VALUE
	DIFFUSER TYPE (SEE SCHEDULES)
	DIFFUSER SIZE
	REVISION CLOUD AND REVISION NUMBER

### LINWEIGHT LEGEND

	LIGHT LINES INDICATES EXISTING ITEMS TO REMAIN
	LIGHT DASHED LINES HIDDEN OR UNDERGROUND ITEMS
	BOLD LINES INDICATES NEW ITEMS
	BOLD DASHED LINES INDICATE EXISTING ITEMS TO BE REMOVED

NOTE:  
 LINWEIGHTS ARE GENERAL GUIDES ONLY. REFER TO DRAWING NOTES AND WORK PHASES (DEMO OR NEW) FOR ADDITIONAL DISTINCTIONS.

CAD NO. 23010

09/20/23

DATE	APP.	INT.	REVISIONS	NO.

ACTION	BY	DATE
DESIGNED	ASD	09-20-23
DRAWN	ASD	09-20-23
CHECKED (FIELD)	XX	XX/XX/XX
CHECKED (HDQTS.)	XX	XX/XX/XX



PROJECT ENGINEER

WASHINGTON STATE PARKS AND RECREATION COMMISSION

LEWIS & CLARK TRAIL STATE PARK

COMFORT STATION RENOVATION

MECHANICAL SCHEDULES, NOTES, LEGENDS, ABBREVIATIONS

SHEET 7 OF 17

SCALE



PARKS FILE#

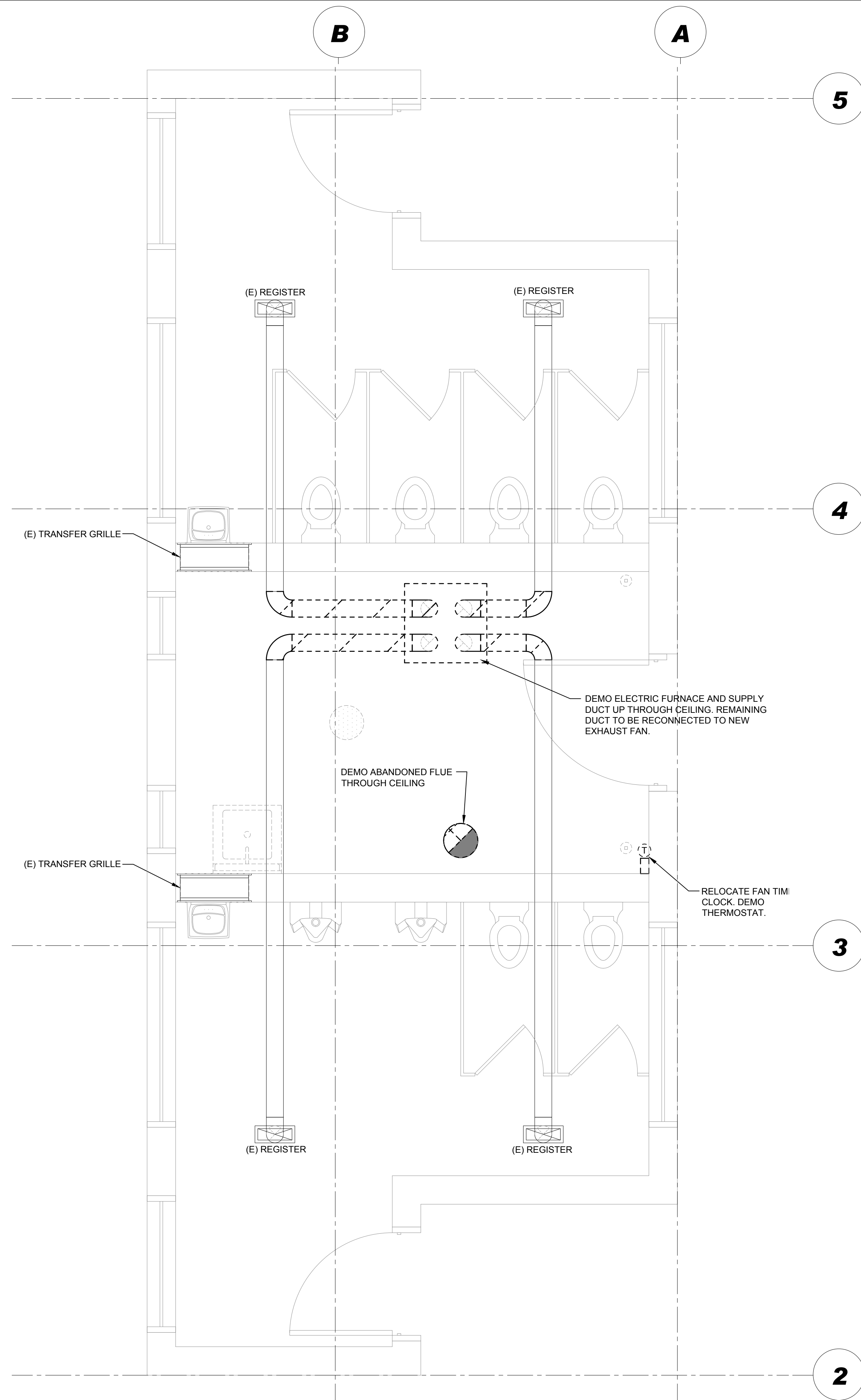



**2** MECHANICAL DEMO PLAN - HVAC

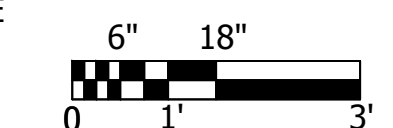

CAD NO. 23010		
09/20/23	DATE	
	APP.	
	INT.	
	REVISIONS	
	NO.	
ACTION	BY	DATE
DESIGNED	ASD	09-20-23
DRAWN	ASD	09-20-23
CHECKED (FIELD)	XX	XX/XX/XX
CHECKED (HDQTS.)	XX	XX/XX/XX
 PROJECT ENGINEER		
<b>WASHINGTON STATE PARKS AND RECREATION COMMISSION</b> 		
<b>LEWIS &amp; CLARK TRAIL STATE PARK</b>		
<b>COMFORT STATION RENOVATION</b>		
<b>MECHANICAL DEMO PLAN - HVAC</b>		
SHEET 8 OF 17		
SCALE 		
PARKS FILE#		

09/20/23

DATE

APP.

INT.

REVISIONS

NO.

ACTION	BY	DATE
DESIGNED	ASD	09-20-23
DRAWN	ASD	09-20-23
CHECKED (FIELD)	XX	XX/XX/XX
CHECKED (HDQTS.)	XX	XX/XX/XX



PROJECT ENGINEER

WASHINGTON STATE PARKS AND RECREATION COMMISSION



LEWIS & CLARK TRAIL STATE PARK

COMFORT STATION RENOVATION

MECHANICAL FLOOR PLAN - HVAC

SHEET 9 OF 17

SCALE

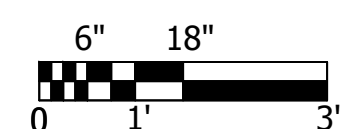

PARKS FILE#

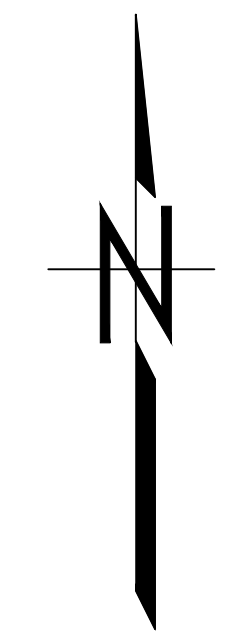
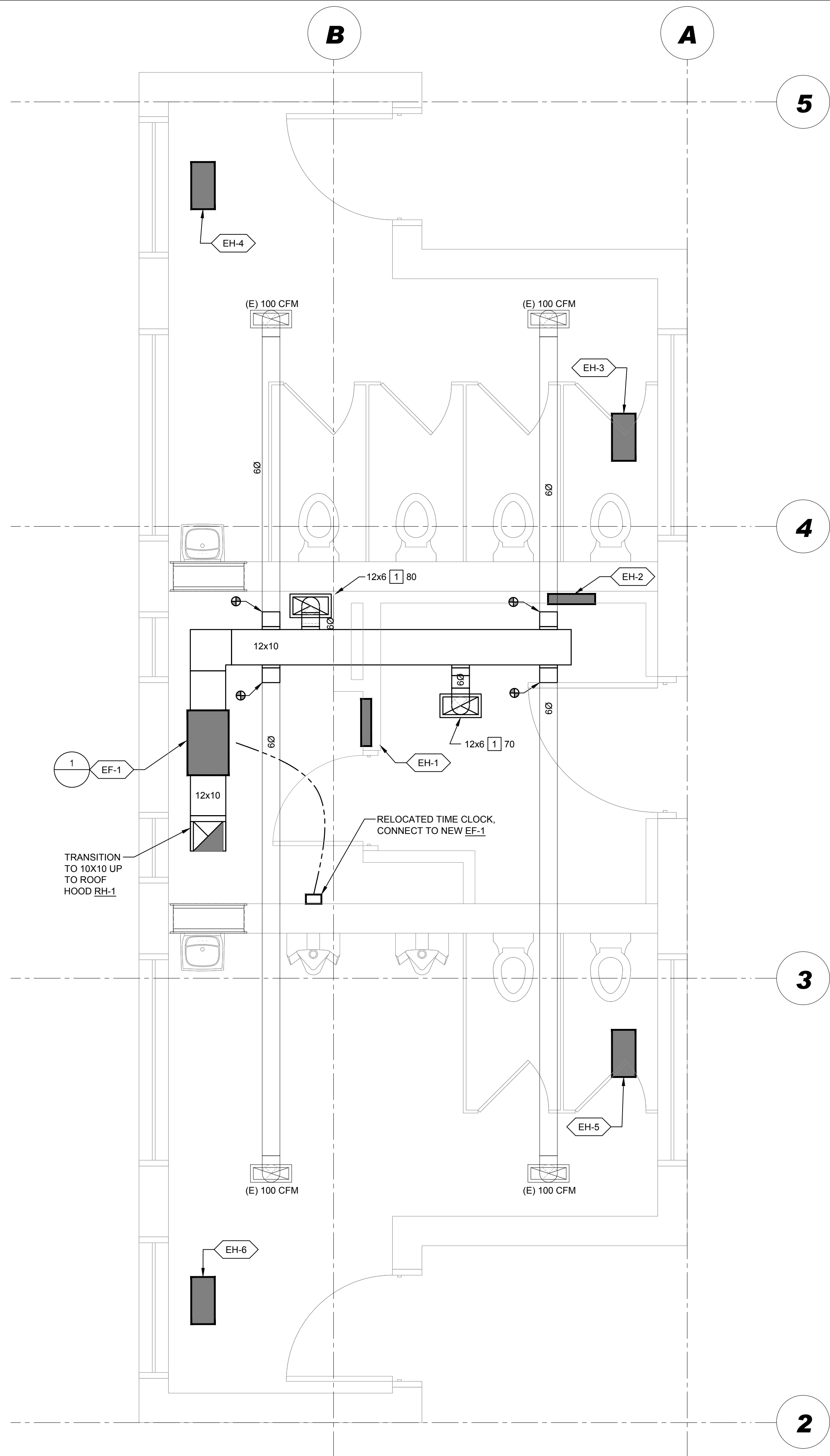
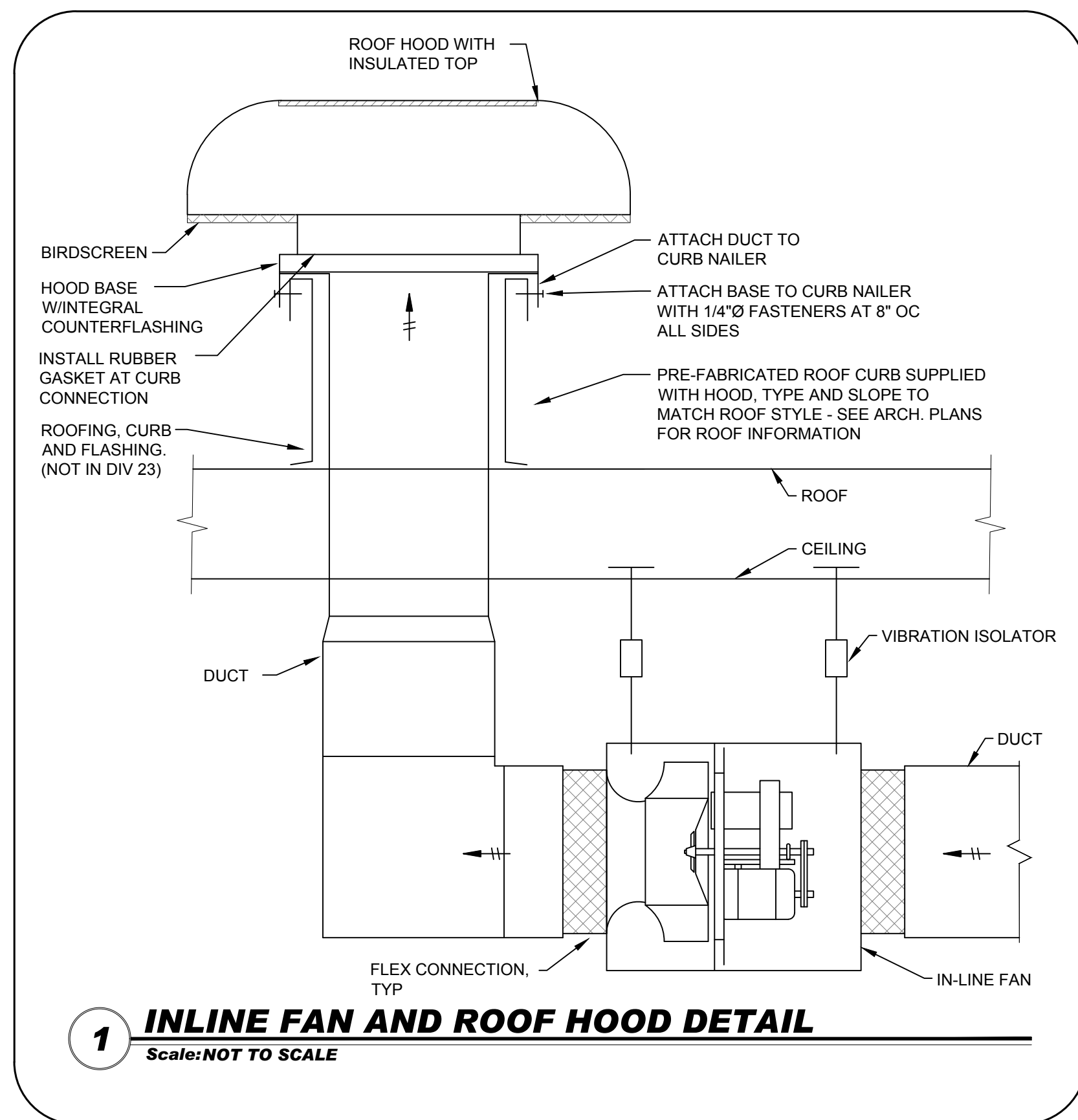

2 MECHANICAL FLOOR PLAN - HVAC

09/20/23

DATE

APP.

INT.

REVISIONS

NO.

ACTION	BY	DATE
DESIGNED	ASD	09-20-23
DRAWN	ASD	09-20-23
CHECKED (FIELD)	XX	XX/XX/XX
CHECKED (HDQTS.)	XX	XX/XX/XX



PROJECT ENGINEER

# WASHINGTON STATE PARKS AND RECREATION COMMISSION



## LEWIS & CLARK TRAIL STATE PARK

# COMFORT STATION RENOVATION

## PLUMBING SCHEDULES, NOTES, LEGENDS, ABBREVIATIONS

SHEET 10 OF 17

SCALE

PARKS FILE#

### PLUMBING FIXTURES

#	FIXTURE	MFR	MODEL #	MOUNTING	MATERIAL	SIZE	MFR & MODEL# OF FAUCET & VALVE	DRAIN	CARRIER	TRAP	W	V	HW	CW	STOPS	NOTES
P1	SERVICE SINK	ACORN	TRH-24	FLOOR	TERRAZZO	24"x24"x12"	CHICAGO 897-CP	INTEGRAL	-	3" P-TRAP	3"	2"	3/4"	3/4"	-	③④
P2	ADA WATER CLOSET	AMERICAN STANDARD	AFWALL 2257101.020	WALL	VITREOUS CHINA	ELONGATED BOWL	SLOAN ROYAL 111 1.6-TP	-	JAY R. SMITH 0200 SERIES	INTEGRAL	4"	2"	-	1"	INTEGRAL	②③
P3	ADA LAVATORY	AMERICAN STANDARD	LUCERNE 0355.012	WALL	VITREOUS CHINA	20"x18"	CHICAGO 3502-E2805ABCP	ELKAY LKAD174	JAY R. SMITH 0700 SERIES	1/4"x17GA C.P.	1 1/2"	1 1/2"	1/2"	1/2"	BRASS CRAFT STCR1915A	①②③

- NOTES:**
- PROVIDE WITH TRUEBRO TRAP & SUPPLIES WRAP KIT.
  - MOUNT PER ADA REQUIREMENTS.
  - CAULK FIXTURE AT FLOOR, COUNTERTOP AND/OR WALL SURFACE WITH CAULKING.
  - PROVIDE WITH HOSE, HOSE HANGER AND MOP HANGER.

### FLOOR DRAIN SCHEDULE

FD#	MFR	MODEL	TYPE	BODY		STRAINER/GRATE		VARIATION	NOTES
				STYLE	MATERIAL	STYLE	MATERIAL		
FD-1	JAY R. SMITH	2005-A-P-U-Y	FLOOR DRAIN	-	CAST IRON	VANDAL-PROOF ROUND	NICKEL BRONZED	TRAP PRIMER	①
FD-2	JAY R. SMITH	2142Y-P050	FLOOR DRAIN	-	CAST IRON	VANDAL-PROOF ROUND	CAST IRON	TRAP PRIMER	

- NOTES:**
- PROVIDE WITH SUFFIX -C WHEN LOCATED IN MECHANICAL ROOMS AND SIMILAR SPACES.

### WATER HEATER SCHEDULE

#	MFR	MODEL	GALLONS	KW INPUT	THERMAL EFFICIENCY	TEMPERATURES OUTLET (°F)	RISE (°F)	RECOVERY (GPH)	ELECTRICAL	NOTES
WH-1	A.O. SMITH	DEL-15	19	1.5	99.86%	120	80	8	240V / 1PH	①
DET-1	AMTROL	ST-12	4.4	-	-	-	-	-	-	-

- NOTES:**
- SINGLE ELEMENT / NON-SIMULTANEOUS OPERATION

### WATER HAMMER ARRESTER SIZING CHART

SYMBOL	FIXTURE UNIT RATING	CONNECTION TO SUPPLY PIPE
WHA-1	1-11	3/4"
WHA-2	12-32	1"

### GENERAL NOTES

- THE PLUMBING SYSTEM SHALL CONSIST OF ALL WORK SHOWN ON DRAWINGS, DIAGRAMS AND AS DESCRIBED IN SPECIFICATIONS.
- COORDINATE WITH SPECIFICATIONS. IN CASE OF DISCREPANCY BETWEEN SPECIFICATIONS AND DRAWINGS REFER TO THE GENERAL CONDITIONS AND NOTIFY THE A/E FOR DIRECTION.
- INSTALL ALL PLUMBING WORK AS HIGH AS POSSIBLE. TIGHT TO STRUCTURE ABOVE. COORDINATE ALL EXPOSED PLUMBING SYSTEMS SO THAT LOCATIONS AND ROUTING ARE INTEGRATED WITH THE OTHER BUILDING ELEMENTS (WALLS, ROOFS, JOISTS, LIGHTS, ETC.). GENERALLY RUN SYSTEMS PARALLEL OR PERPENDICULAR TO BUILDING ELEMENTS AND RUN IN A MANNER TO CONCEAL OR BLEND WITH BUILDING LINES.
- PROVIDE NEC CODE MINIMUM HORIZONTAL AND VERTICAL WORKING CLEARANCES FOR ALL ELECTRICAL PANELS AND EQUIPMENT. OFFSET PLUMBING WORK AS REQUIRED.
- COORDINATE ALL PLUMBING WORK WITH THAT OF OTHER TRADES TO ENSURE PROPER INTERFACE, ADEQUATE CLEARANCES, AND TO AVOID CONFLICTS. PROVIDE FIELD COORDINATION AND/OR DRAWINGS PRIOR TO FABRICATION AND/OR INSTALLATION. CONFLICTS AND INTERFERENCES THAT COULD HAVE BEEN AVOIDED BY PROPER PRE-PLANNING AND COORDINATION SHALL BE REMOVED AND CORRECTED AT NO COST TO THE OWNER.
- FIELD LOCATE ALL ROOF, FLOOR AND WALL PENETRATIONS AND ADJUST TO AVOID CONFLICT WITH STRUCTURAL ELEMENTS, BEAMS, CROSS-BRACING, ARCHITECTURAL ELEMENTS. DIV. 22 CONTRACTOR IS RESPONSIBLE FOR LOCATING AND COORDINATING ALL SAW CUTTING AND DRILLING REQUIRED FOR MECHANICAL SYSTEM OPENINGS.
- ITEMS NOTED "TYPICAL" OR "TYP" ON ANY SHEET APPLY TO THAT PARTICULAR SHEET.
- MODEL NUMBERS OF EQUIPMENT SHOWN ON THE SCHEDULES AND THROUGHOUT THE DRAWINGS AND SPECIFICATIONS SHALL NOT BE CONSIDERED COMPLETE AND MATERIAL SHALL NOT BE ORDERED BY MFR/MODEL ALONE. REVIEW THE COMPLETE DESCRIPTION, NOTES AND SPECIFICATIONS TO DETERMINE THE EXACT MATERIAL AND ACCESSORIES TO BE ORDERED. THE MANUFACTURERS LISTED ARE THE BASIS OF DESIGN.
- ALL INSULATED PIPING EXPOSED TO VIEW IN OCCUPIED SPACES SHALL BE PROVIDED WITH PVC JACKETING.
- PROVIDE TRAP PRIMERS ON ALL FLOOR DRAINS AND FLOOR SINKS. UNLESS NOTED OTHERWISE. TRAP PRIMER SOURCES SHALL BE EITHER FROM AUTOMATIC, ELECTRONIC TRAP PRIMER UNITS LOCATED IN THE VICINITY (FOR CLUSTERS OF MULTIPLE DRAINS), WATER CLOSET FLUSH VALVE TAPS, SINK TAIL PIECE BRANCHES, OR PRESSURE DROP OPERATED UNITS AS BEST FITS THE SITUATION. ALL FLOOR DRAINS AND FLOOR SINKS IN KITCHENS, MECHANICAL MEZZANINES, AND MECHANICAL ROOMS ARE REQUIRED TO BE INSTALLED WITH AUTOMATIC ELECTRONIC TRAP PRIMER UNITS.
- PROVIDE AN ACCESS PANEL WHERE REQUIRED FOR ACCESS TO WATER HAMMER ARRESTORS. PROVIDE WATER HAMMER ARRESTORS AT THE FOLLOWING LOCATIONS:
  - HOT AND COLD WATER SERVING ALL RESTROOMS
  - AT ALL FLUSH VALVES AND OTHER QUICK ACTING VALVES
  - FIXTURES LOCATED AT THE END OF MAIN AND BRANCH PIPING RUNS
  - IN WATER SUPPLIES TO REMOTE SINKS
- SMALL PIPING OR COMPONENTS: PIPING PLANS DO NOT NECESSARILY SHOW ALL SMALL PIPING OR COMPONENTS, INSTRUMENT TAPS OR DRAINS. PROVIDE ALL PIPING, VALVES, SPECIALTY ITEMS, INSTRUMENTATION, ETC. AS INDICATED ON THE PIPING FLOW DIAGRAMS, PIPING/EQUIPMENT DETAILS AND/OR CONTROL INSTRUMENTATION DIAGRAMS.
- THE MECHANICAL AND PLUMBING PLANS ARE DIAGRAMMATIC IN NATURE AND DO NOT ATTEMPT TO SHOW ALL REQUIRED OFFSETS AND FITTINGS. PROVIDE ALL NECESSARY OFFSETS, TRANSITIONS AND FITTINGS REQUIRED FOR A COMPLETE SYSTEM. REFER TO ARCHITECTURAL, STRUCTURAL, PLUMBING AND ELECTRICAL DRAWINGS FOR COORDINATION PURPOSES TO AVOID CONFLICTS.
- COORDINATE ALL EXPOSED PLUMBING SYSTEMS SO LOCATIONS AND ROUTING ARE INTEGRATED WITH THE OTHER BUILDING ELEMENTS (WALLS, ROOFS, JOISTS, LIGHTS, ETC.). GENERALLY RUN SYSTEMS PARALLEL OR PERPENDICULAR TO BUILDING ELEMENTS AND RUN IN A MANNER TO CONCEAL OR BLEND WITH BUILDING LINES.
- COORDINATE ALL WORK WITH THAT OF OTHER TRADES TO ENSURE PROPER INTERFACE, ADEQUATE CLEARANCES, AND TO AVOID CONFLICTS. PROVIDE FIELD COORDINATION AND/OR DRAWINGS PRIOR TO FABRICATION AND/OR INSTALLATION. CONFLICTS AND INTERFERENCES THAT COULD HAVE BEEN AVOIDED BY PROPER PRE-PLANNING AND COORDINATION SHALL BE REMOVED AND CORRECTED AT NO COST TO THE OWNER.
- HANGERS, SUPPORTS AND ANCHORS FOR MECHANICAL AND PLUMBING SYSTEMS AND EQUIPMENT ARE NOT NECESSARILY DESIGNED OR SHOWN ON THE DRAWINGS. THE CONTRACTOR SHALL PROVIDE ALL NECESSARY SUPPORT MEMBERS, HANGERS, BRACKETS, HARDWARE, CLEVIS HANGERS, RODS, ETC. ANCHOR SUPPORTS TO BUILDING STRUCTURE OR OTHER APPROPRIATE BUILDING ELEMENTS.
- COORDINATE THE FURNISHING AND INSTALLATION OF ALL ELECTRICAL DISCONNECT SWITCHES, STARTERS, VFDs, ETC. IN ORDER TO ASSURE THAT ALL ENERGIZED EQUIPMENT IS PROVIDED WITH THE REQUIRED CIRCUIT PROTECTION METHODS AND CONTROL DEVICES. WHERE DRAWINGS, NOTES, SCHEDULES AND EQUIPMENT SPECIFICATIONS ARE SILENT OR UNCLEAR AS TO WHICH DIVISION (22-PLBG, 23-HVAC, OR 26-ELECTRICAL) IS TO PROVIDE THESE DEVICES, THE CONTRACTOR SHALL CONTACT THE ENGINEER, PRIOR TO BID.

### ABBREVIATIONS

AAV	AUTOMATIC AIR VENT	HW	HOT WATER
ABV	AIR COOLED CONDENSING UNIT	HX	HEAT EXCHANGER
ACCU	AIR COOLED CONDENSING UNIT	HZ	HERTZ
AD	ACCESS DOOR	ID	INSIDE DIAMETER
AFS	AIR FLOW SWITCH	INV	INVERT
AFF	ABOVE FINISHED FLOOR	I.E.	INVERT ELEVATION
AG	ABOVE GROUND	INSUL	INSULATION
AHU	AIR HANDLING UNIT	IND	INDIRECT
AL	ACOUSTICALLY LINED	KW	KILOWATT
ALUM	ALUMINUM	KWH	KILOWATT HOUR
APD	AIR PRESSURE DROP	L	LENGTH OR LOUVER
ARCH	ARCHITECT	LAT	LEAVING AIR TEMPERATURE
AVG	AVERAGE	LBS	POUNDS
AWT	AVERAGE WATER TEMPERATURE	LDB	LEAVING DRY BULB
BAS	BUILDING AUTOMATION SYSTEM	LF	LINEAR FOOT
BDD	BACKDRAFT DAMPER	LWT	LEAVING WATER TEMPERATURE
BFF	BELOW FINISHED FLOOR	LG	LONG OR LENGTH
BFP	BACKFLOW PREVENTER	LJP	LOW POINT
BG	BELOW GROUND	LWB	LEAVING WET BULB
BHP	BRAKE HORSEPOWER	LWG	LOW WALL GRILLE
BLDG	BUILDING	LWT	LEAVING WATER TEMPERATURE
BP	BYPASS	LVG	LEAVING
BTU	BRITISH THERMAL UNIT	MCA	MINIMUM CIRCUIT AMPACITY
BTUH	BRITISH THERMAL UNITS PER HOUR	MCCP	MAXIMUM OVERCURRENT PROTECTION
BOD	BOTTOM OF DUCT	MBH	THOUSAND (1000) BTU PER HOUR
BOP	BOTTOM OF PIPE	MCC	MOTOR CONTROL CENTER
BSMT	BASEMENT	MFR	MANUFACTURER
BV	BALANCING VALVE	MS	MOTOR STARTER
C	CELLS	MTD	MOUNTED
CA	COMBUSTION AIR	MTG	MOUNTING
CAP	CAPACITY	MAU	MAKE-UP AIR UNIT
CC	CENTER TO CENTER OR COOLING COIL	NC	NORMALLY CLOSED
CD	CEILING DIFFUSER	NO	NORMALLY OPEN
CFM	CUBIC FEET PER MINUTE	MOD	MOTOR OPERATED DAMPER
CG	CEILING GRILLE	NIC	NOT IN CONTRACT
CI	CAST IRON	NPT	NATIONAL PIPE THREAD
CLG	CEILING	NTS	NOT TO SCALE
COG	CLEAN OUT TO GRADE	OA	OUTDOOR AIR
CO	CLEAN OUT	OB	OPPOSED BLADE DAMPER
COMB	COMBUSTION	OD	OUTSIDE DIAMETER
COND	CONDENSATE OR CONDENSER	OSA	OUTSIDE AIR
CONC	CONCRETE	OAT	OUTSIDE AIR TEMPERATURE OVERFLOW
CONST	CONSTRUCTION	OF	OWNER FURNISHED, CONTRACTOR INSTALLED
COP	COEFFICIENT OF PERFORMANCE	PD	PRESSURE DROP
CU	COPPER	PH	PHASE
CUH	CABINET UNIT HEATER	PIAC	PRESSURE INDEPENDENT AIR CONTROLLER
CW	COLD WATER	PG	PROPYLENE GLYCOL
CU	CONDENSING UNIT	PLBG	PLUMBING
CR	CONDENSATE RETURN	POC	POINT OF CONNECTION
CL	CENTER LINE	PRV	PRESSURE REDUCING VALVE
D	DEEP OR DEPTH	PSI	POUNDS PER SQUARE INCH
DB	DRY BULB OR DECIBEL	PSIG	POUNDS PER SQUARE INCH GAUGE
DBA	A-WEIGHTED DECIBELS	PT	PRESSURE & TEMPERATURE
DDC	DIRECT DIGITAL CONTROLS	RA	RETURN AIR
DEMO	DEMOLITION	RAG	RETURN AIR GRILLE
DN	DOWN	RAT	RETURN AIR TEMPERATURE
DIA	DIAMETER Ø	RD	ROOF DRAIN
DPS	DIFFERENTIAL PRESSURE SWITCH	RET	RETURN
DP	DROP	REV	REVISION
DPR	DAMPER	RF	RETURN FAN
DWG	DRAWING	RPM	REVOLUTIONS PER MINUTE
(E)	EXISTING	RHW	RECIRCULATING HOT WATER
EA	EACH OR EXHAUST AIR	RTU	ROOF TOP UNIT
EAT	ENTERING AIR TEMPERATURE	S	SINK
EDB	ENTERING DRY BULB	SA	SUPPLY AIR
EEF	ENERGY EFFICIENCY RATIO	SAT	SUPPLY AIR TEMPERATURE
EF	EXHAUST FAN	SEER	SEASONAL ENERGY EFFICIENT RATIO
EFF	EFFICIENCY	SENS	SENSIBLE
EG	EXHAUST GRILLE	SD	SMOKE DETECTOR OR DAMPER
ELEC	ELECTRIC OR ELECTRICAL	SF	SUPPLY FAN
ELEV	ELEVATION	SFD	SMOKE-FIRE DAMPER
EMCS	ENERGY MANAGEMENT AND CONTROL SYSTEM	SHT	SHEET
ENCL	ENCLOSURE	SP	STATIC PRESSURE
EQUIP	EQUIPMENT	SQ	SQUARE
ESP	EXTERNAL STATIC PRESSURE	SQ	FT SQUARE FOOT
EST	ESTIMATE(D)	SS	STAINLESS STEEL
EWB	ENTERING WET BULB	STD	STANDARD
EWT	TEMPERATURE	TA	TRANSFER AIR
EXH	EXHAUST	TEMP	TEMPERATURE
F	FAHRENHEIT	TH	THICK OR THICKNESS
FA	FRESH AIR (OUTSIDE AIR)	TOD	TOP OF DUCT
FCO	FLOOR CLEAN OUT	TOP	TOP OF PIPE
FCU	FAN COIL UNIT	TP	TRAP PRIMER
FD	FIRE DAMPER OR FLOOR DRAIN	TU	TERMINAL UNIT
FDC	FIRE DEPARTMENT CONNECTION	TYP	TYPICAL
FF	FINAL FILTER	UF	UNDER FLOOR
FLA	FULL LOAD AMPS	UG	UNDERGROUND
FLR	FLOOR	UH	UNIT HEATER
FLEX	FLEXIBLE	UR	URINAL
FOB	FLAT ON BOTTOM	US	UNDER SLAB
FOT	FLAT ON TOP	V	VENT OR VOLT
FPM	FEET PER MINUTE	VAC	VACUUM
FPI	FINS PER INCH	VAV	VARIABLE AIR VOLUME
FPS	FEET PER SECOND	VEL	VELOCITY
FP	FIRE PROTECTION	VFD	VARIABLE FREQUENCY DRIVE
FS	FLOOR SINK	VRF	VARIABLE REFRIGERANT FLOW
FT	FEET/FOOT OR FINNED TUBE	VRV	VARIABLE REFRIGERANT VOLUME
FV	FACE VELOCITY	VTR	VENT THRU ROOF
G	GAS (NATURAL)	VD	VOLUME DAMPER
GA	GAUGE OR GAGE	W	WIDE OR WIDTH
GAL	GALLONS	WB	WET BULB
GALV	GALVANIZED	WC	WATER CLOSET
GPM	GALLONS PER MINUTE	WCO	WALL CLEAN OUT
GYP	GYPSPUM WALL BOARD	WH	WATER HEATER
H	HIGH OR HEIGHT	WHA	WATER HAMMER ARRESTOR
HB	HOSE BIBB	WG	WATER GAUGE
HD	HEAD	WPD	WATER PRESSURE DROP
HGBP	HOT GAS BYPASS	WT	WEIGHT
HL	HIGH LIMIT		
HP	HORSEPOWER OR HIGH POINT		

### PLUMBING SYMBOLS

↯	ELBOW UP
↷	ELBOW DOWN
⊥	TEE UP
⊥↓	TEE DOWN
⊥↻	CONCENTRIC REDUCER/INCREASER
⊥↻↻	ECCENTRIC REDUCER/INCREASER
⊥↻↻↻	UNION
↻↻↻	RISE/DROP IN PIPE
↻↻↻↻	VENT THRU ROOF
⊥	CAP
⊥	CLEAN-OUT (WALL)
⊥	CLEAN-OUT (FLUSH TO FLOOR OR GRADE)
⊙	FLOOR DRAIN
⊙↻	CIRCULATING PUMP
⊥↻	VALVE (AS INDICATED OR SPECIFIED)
⊥↻↻	CHECK VALVE
⊥↻↻↻	PRESSURE & TEMPERATURE RELIEF VALVE
⊥↻↻↻↻	PRESSURE REDUCING VALVE (POINTS TOWARDS LOW PRESSURE)
⊥↻↻↻↻↻	GAS VALVE
⊥↻↻↻↻↻↻	SOLENOID VALVE
⊥↻↻↻↻↻↻↻	HOSE BIBB
⊥↻↻↻↻↻↻↻↻	CIRCUIT SETTER
⊥↻↻↻↻↻↻↻↻↻	VALVE BOX W/ VALVE (AS SPECIFIED)
⊥↻↻↻↻↻↻↻↻↻↻	THERMOMETER
⊥↻↻↻↻↻↻↻↻↻↻↻	PRESSURE GAGE

### PLUMBING LEGEND

---	COLD WATER
- - - - -	HOT WATER
- · - · - · -	HOT WATER RETURN
- - - - -	VENT
- - - - - SAN	SANITARY DRAIN ABOVE FLOOR
- - - - - SAN	SANITARY DRAIN BELOW FLOOR
- - - - - ST	STORM DRAIN ABOVE FLOOR
- - - - - ST	STORM DRAIN BELOW FLOOR

### GENERAL SYMBOLS

1	SECTION IDENTIFYING NUMBER
M5.01	CROSS-SECTION SYMBOL
1	SHEET WHERE SECTION IS SHOWN
M6.01	DETAIL IDENTIFYING NUMBER
1	DETAIL SYMBOL
M6.01	SHEET WHERE DETAIL IS SHOWN
⊕	POINT OF CONNECTION (POC) SYMBOL
RCP-1	EQUIP. TYPE-NUMBER (SEE SCHEDULES)
RCP-1	EQUIPMENT IDENTIFIER (OPTIONAL TAG STYLE)
1	REVISION CLOUD AND REVISION NUMBER

### LINEWEIGHT LEGEND

---	LIGHT SOLID LINES INDICATES EXISTING ITEMS TO REMAIN
- - - - -	LIGHT DASHED LINES GENERALLY INDICATE HIDDEN OR UNDERGROUND PIPING OR EQUIPMENT
---	DARK LINE INDICATES NEW PIPING & EQUIPMENT
- - - - -	DARK DASHED LINES INDICATE EXISTING PIPING & EQUIPMENT TO BE REMOVED (FLOOR PLANS & SECTIONS)
- - - - -	DASHED LINES INDICATE EXISTING PIPING & EQUIPMENT TO BE REMOVED (DEMOLITION DETAILS & FLOW DIAGRAMS)

**NOTE:** LINEWEIGHTS ARE GENERAL GUIDES ONLY. REFER TO DRAWING NOTES AND WORK PHASES (DEMO OR NEW) FOR ADDITIONAL DISTINCTIONS.

09/20/23

DATE

APP.

INT.

REVISIONS

NO.

ACTION	BY	DATE
DESIGNED	ASD	09-20-23
DRAWN	ASD	09-20-23
CHECKED (FIELD)	XX	XX/XX/XX
CHECKED (HDQTS.)	XX	XX/XX/XX



PROJECT ENGINEER

WASHINGTON  
STATE  
PARKS  
AND  
RECREATION  
COMMISSION



LEWIS & CLARK  
TRAIL STATE PARK

COMFORT STATION  
RENOVATION

PLUMBING DEMO  
PLAN

SHEET 11 OF 17

SCALE

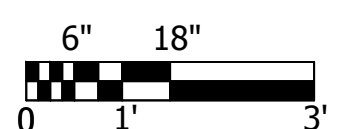

PARKS FILE#

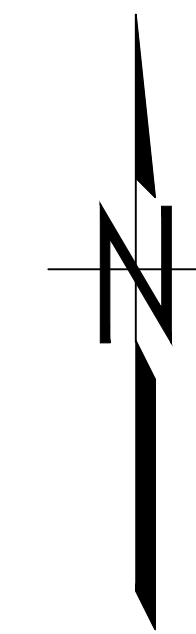
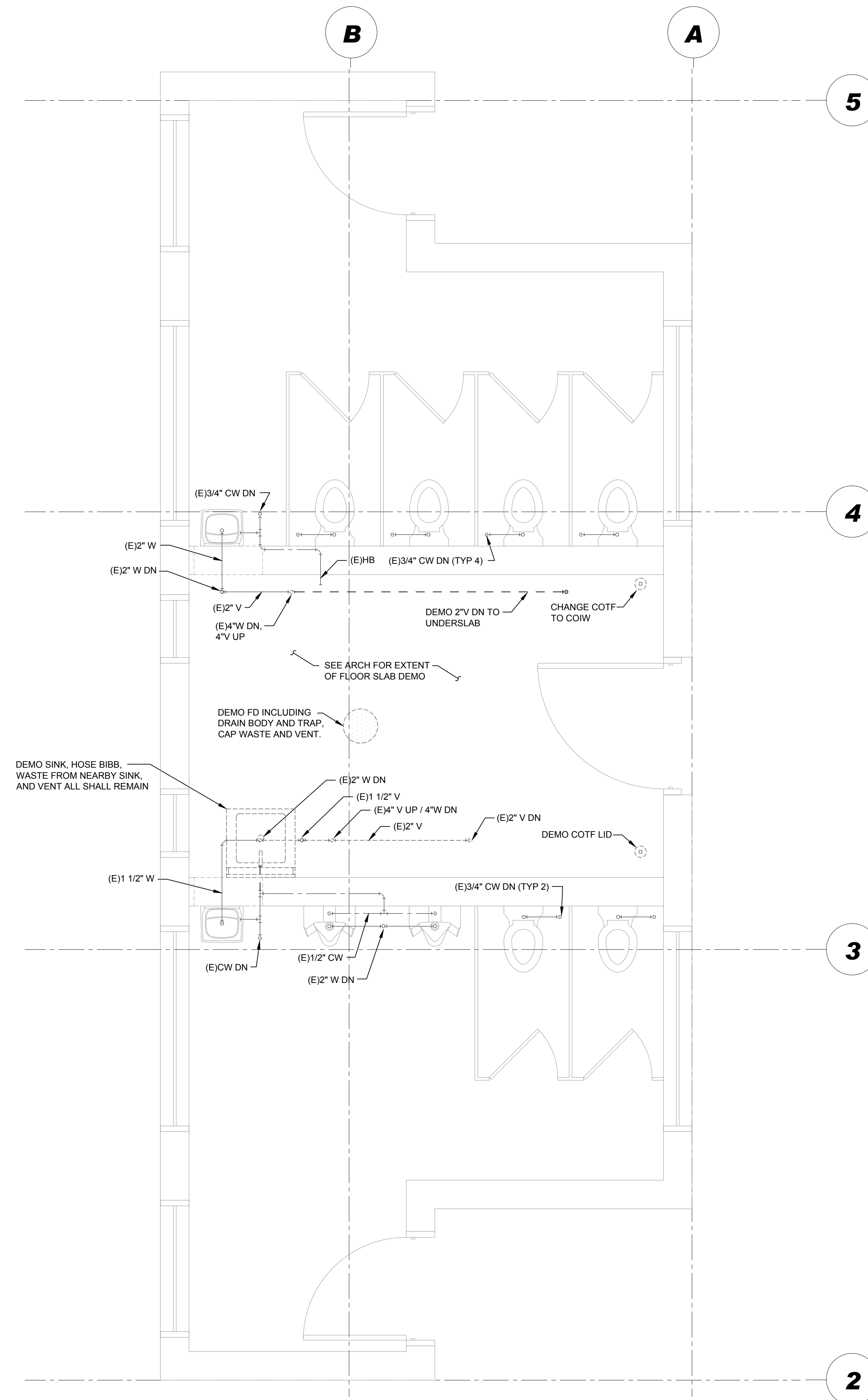

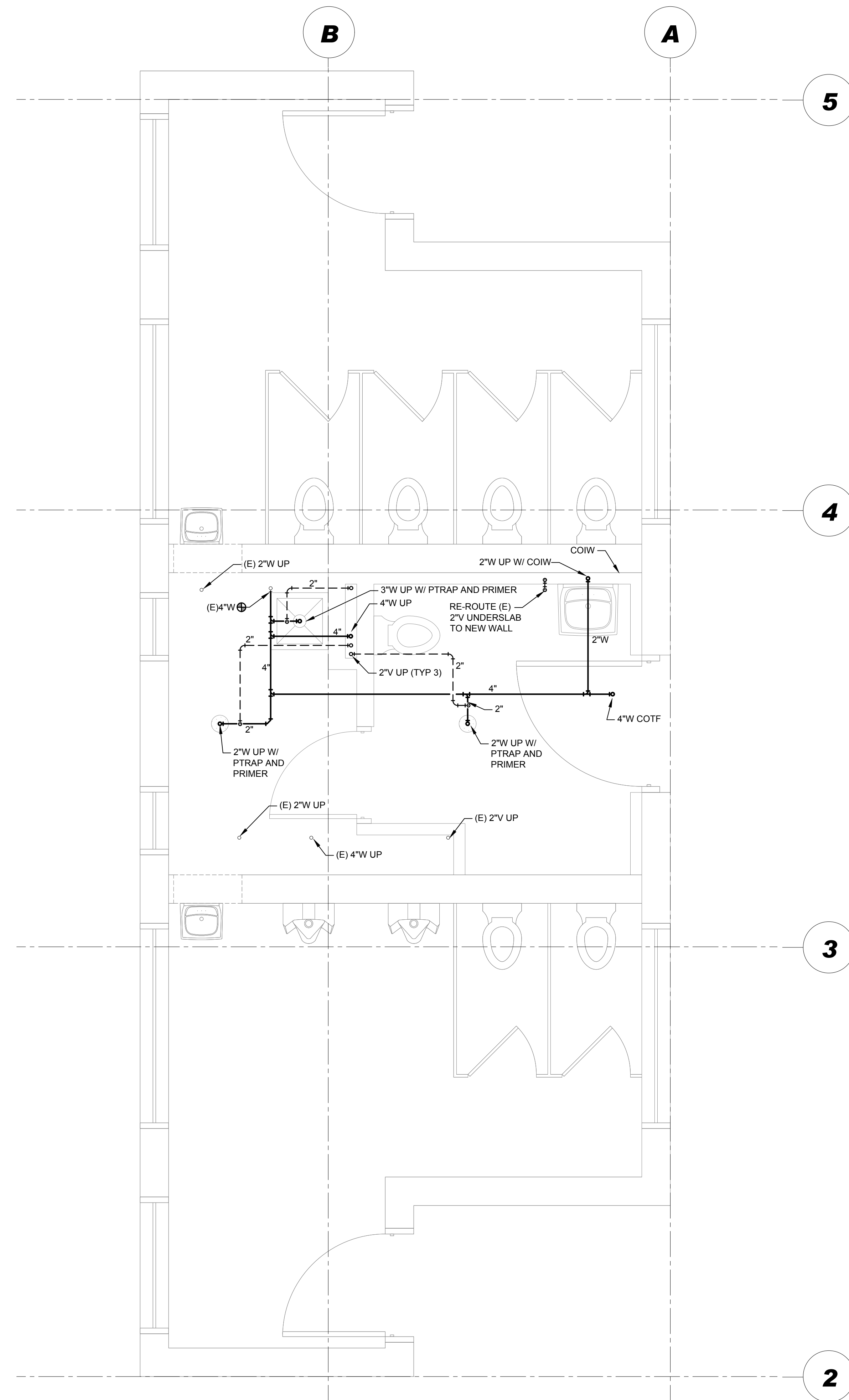

PLUMBING DEMO PLAN

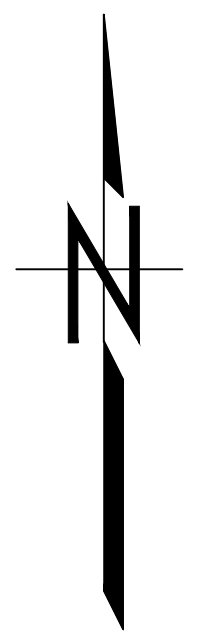

**2** PLUMBING FOUNDATION PLAN

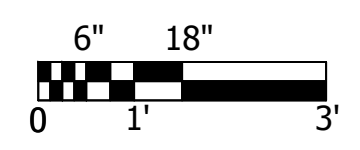

CAD NO. 23010	
09/20/23	DATE
APP.	DATE
INT.	DATE
NO.	DATE
REVISIONS	
ACTION	BY DATE
DESIGNED	ASD 09-20-23
DRAWN	ASD 09-20-23
CHECKED (FIELD)	XX XX/XX/XX
CHECKED (HDQTS.)	XX XX/XX/XX
 <p style="font-size: 0.8em;">PROJECT ENGINEER</p>	
<p style="font-size: 1.1em; margin: 0;">WASHINGTON STATE PARKS AND RECREATION COMMISSION</p> 	
<p style="font-size: 1.1em; margin: 0;">LEWIS &amp; CLARK TRAIL STATE PARK</p>	
<p style="font-size: 1.1em; margin: 0;">COMFORT STATION RENOVATION</p>	
<p style="font-size: 1.1em; margin: 0;">PLUMBING FOUNDATION PLAN</p>	
SHEET 12 OF 17	
<p style="font-size: 0.8em;">SCALE</p> 	
PARKS FILE#	

09/20/23

DATE

APP.

INT.

REVISIONS

NO.

ACTION	BY	DATE
DESIGNED	ASD	09-20-23
DRAWN	ASD	09-20-23
CHECKED (FIELD)	XX	XX/XX/XX
CHECKED (HDQTS.)	XX	XX/XX/XX



PROJECT ENGINEER

WASHINGTON  
STATE  
PARKS  
AND  
RECREATION  
COMMISSION



LEWIS & CLARK  
TRAIL STATE PARK

COMFORT STATION  
RENOVATION

PLUMBING FLOOR  
PLAN

SHEET 13 OF 17

SCALE

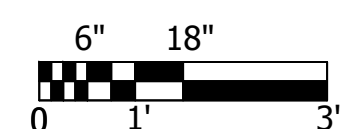

PARKS FILE#

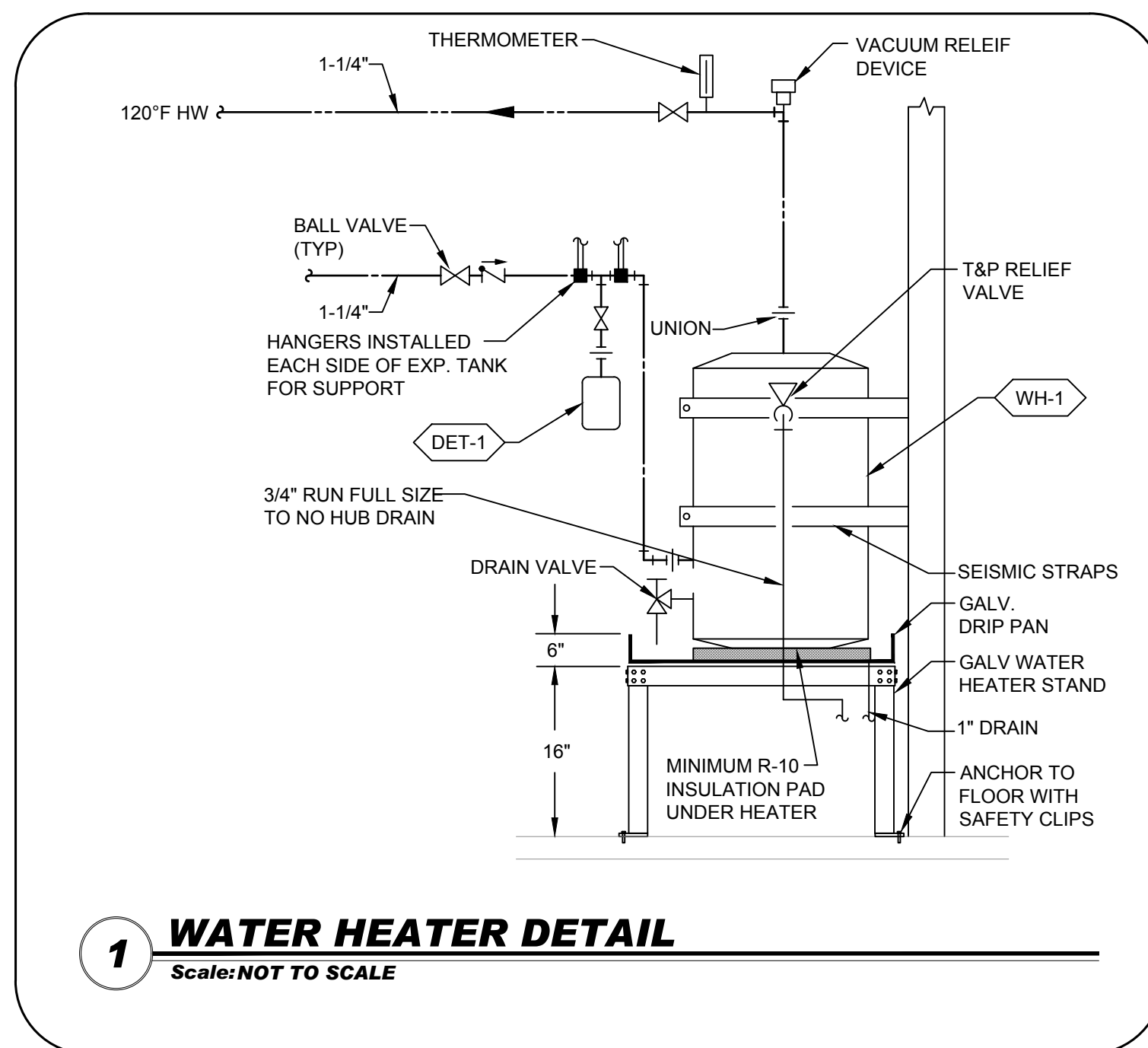
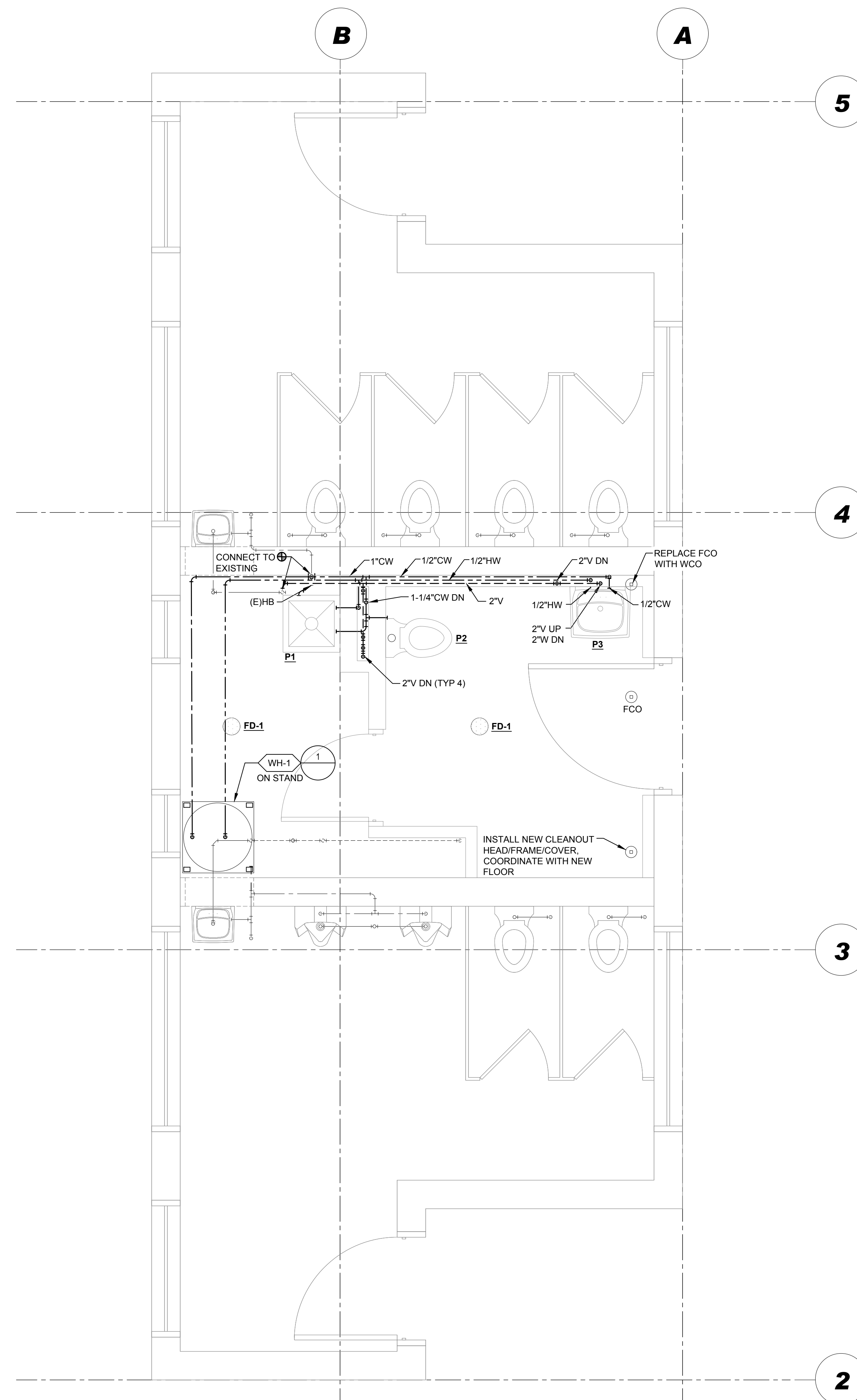

PLUMBING FLOOR PLAN

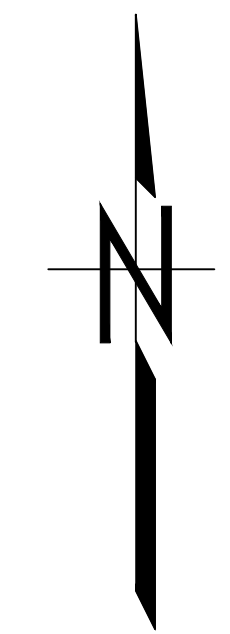

GENERAL NOTES (RE: ALL ELECTRICAL SHEETS)																				
1.	ALL ELECTRICAL EQUIPMENT AND SYSTEMS SHALL BE INSTALLED IN ACCORDANCE WITH THE NATIONAL ELECTRICAL CODE, INTERNATIONAL FIRE CODE, AND ALL OTHER STATE AND LOCAL CODES. CONTRACTOR SHALL IMMEDIATELY NOTIFY ENGINEER IN WRITING IF PORTIONS OF THE DESIGN SET OR FIELD CONDITIONS DO NOT MEET REQUIRED CODES.																			
2.	PROVIDE FIRESTOPPING FOR ALL FLOOR AND FIREWALL PENETRATIONS FROM ELECTRICAL DEVICE, RACEWAY, AND CABLE PENETRATIONS. SEE ARCHITECTURAL DRAWINGS FOR FIREWALL LOCATIONS.																			
3.	ALL WIRING DEVICES SHALL BE OF THE SAME MANUFACTURER AND SHALL MATCH THROUGHOUT. COVER PLATES SHALL BE STAINLESS AND DEVICES SHALL BE WHITE.																			
4.	DESIGN OF ELECTRICAL REQUIREMENTS IS BASED ON MECHANICAL EQUIPMENT SPECIFIED. ELECTRICAL CONTRACTOR SHALL COORDINATE WITH MECHANICAL CONTRACTOR IF EQUIPMENT PURCHASED IS DIFFERENT FROM THAT SPECIFIED STILL MEETS DESIGN INTENT, INCLUDING BUT NOT LIMITED TO OVER-CURRENT PROTECTION, LOCAL DISCONNECTING MEANS, AND WIRE SIZING.																			
5.	IT SHALL BE CONTRACTOR'S RESPONSIBILITY TO VERIFY TYPE OF CEILING SYSTEMS AND TO FURNISH APPROVED LIGHTING FIXTURES OF THE TYPE REQUIRED FOR MOUNTING IN SUBJECT CEILING. WHERE FIXTURES ARE RECESSED IN PLASTER OR DRYWALL CEILINGS, THEY SHALL BE COMPLETE WITH NECESSARY MOUNTING HARDWARE AND PLASTER FRAMES.																			
6.	ALL RECESSED LIGHTING FIXTURES, SPEAKERS, RECEPTACLES, SWITCHES, ETC. MOUNTED IN THE FIRE RATED CEILINGS OR WALLS SHALL BE ENCLOSED WITH AN APPROVED ENCLOSURE CARRYING THE SAME FIRE RATING AS THE CEILING OR WALL BY THIS CONTRACTOR.																			
7.	ALL COMMUNICATION CONDUIT SHALL BE 3/4" UNO.																			
8.	COLOR CODE WIRES AS FOLLOWS:	<table border="1"> <thead> <tr> <th>CONDUCTORS</th> <th>120/208V</th> <th>277/480V</th> </tr> </thead> <tbody> <tr> <td>PHASE A</td> <td>BLACK</td> <td>BROWN</td> </tr> <tr> <td>PHASE B</td> <td>RED</td> <td>ORANGE</td> </tr> <tr> <td>PHASE C</td> <td>BLUE</td> <td>YELLOW</td> </tr> <tr> <td>NEUTRAL</td> <td>WHITE</td> <td>WHITE OR GRAY</td> </tr> <tr> <td>GROUND</td> <td>GREEN</td> <td>GREEN</td> </tr> </tbody> </table>	CONDUCTORS	120/208V	277/480V	PHASE A	BLACK	BROWN	PHASE B	RED	ORANGE	PHASE C	BLUE	YELLOW	NEUTRAL	WHITE	WHITE OR GRAY	GROUND	GREEN	GREEN
CONDUCTORS	120/208V	277/480V																		
PHASE A	BLACK	BROWN																		
PHASE B	RED	ORANGE																		
PHASE C	BLUE	YELLOW																		
NEUTRAL	WHITE	WHITE OR GRAY																		
GROUND	GREEN	GREEN																		
9.	ALL SWITCHES TO BE 20 AMP, 277 VOLT, SPECIFICATION GRADE.																			
10.	ALL WIRE SHALL BE STRANDED TYPE THHN/THWN, MINIMUM SIZE #12 UNLESS OTHERWISE INDICATED.																			
11.	NUMBER NEXT TO DEVICE/EQUIPMENT INDICATES PANEL AND POLE POSITION TO WHICH DEVICE/EQUIPMENT SHALL BE CIRCUITED. CIRCUITS SHOWN ARE NEW UNLESS NOTED OTHERWISE (E.G. BY 'E' OR 'EXISTING'). CIRCUITS UNDER 100' SHALL BE 3/4", 2#12, 1#12G UNLESS NOTED OTHERWISE. CIRCUITS 100' OR LONGER SHALL BE 3/4", 2#12, 1#12G UNLESS NOTED OTHERWISE.																			
12.	ALL HOME RUN JUNCTION BOXES SHALL BE A MINIMUM OF 4" SQUARE, 2-1/8" DEEP.																			
13.	FURNISH AND INSTALL A COMPLETE ELECTRICAL SYSTEM AS DEPICTED FROM THE PLANS AND SPECIFICATIONS. COMPLETE AS NOTED OR IMPLIED, NOT LIMITED TO WHAT IS SHOWN.																			
14.	ALL DRAWINGS ARE SCHEMATIC IN NATURE AND ALL APPURTENANCES NOT INDICATED TO MAKE A WORKING SYSTEM MUST BE INCLUDED IN THE CONTRACTOR'S BID.																			
15.	IF THERE APPEAR TO BE ANY ITEMS IN CONFLICT WITH THE DRAWINGS, INCONSISTENCIES WITH DESIGN OR INTENT, OR NEED FOR CLARIFICATION, IT IS THE CONTRACTOR'S RESPONSIBILITY TO CLARIFY THESE ITEMS PRIOR TO BID IN WRITING WITH THE ENGINEER. IF THE CONTRACTOR FAILS TO CLARIFY ANY QUESTIONS OR INCONSISTENCY, HE ACCEPTS RESPONSIBILITY TO CORRECT AT HIS COST ANY SUCH ITEM TO MEET INTENT AS DEFINED BY THE ENGINEER.																			
16.	ALL MOUNTING HEIGHTS OF EQUIPMENT SHALL MEET ADA REQUIREMENTS UNLESS OTHERWISE NOTED.																			
17.	CONDUIT RUNS IN WALLS SHALL BE VERTICAL, MINIMUM SIZE 3/4".																			
20.	COORDINATE ALL DEVICE/FIXTURE LOCATIONS AND SPECIFIC REQUIREMENTS WITH OWNER/ARCHITECT PRIOR TO ROUGH-IN.																			
21.	ALL CONDUIT RUNS USING PVC CONDUIT SHALL USE RGD OR IMC FOR ANY BEND OVER 45 DEGREES AND ALL 90 DEGREE ELBOWS.																			
22.	UNDERGROUND CONDUITS SHALL BE SCHEDULE 40 PVC. MINIMUM OF 1" CONDUIT THROUGHOUT UNDERGROUND SYSTEM UNLESS OTHERWISE INDICATED.																			
23.	ALL CONDUIT PENETRATING SLAB IN EXPOSED LOCATIONS SHALL BE RIGID STEEL.																			
24.	EACH TRADE SUBCONTRACTOR IS RESPONSIBLE FOR SUSPENDED SUPPORTS NOT SHOWN ON STRUCTURAL DRAWINGS. ALL SUBCONTRACTORS SHALL COORDINATE WITH EACH OTHER FOR ELEVATION PRIORITY PLACEMENT OF GRADED PIPES, LARGE DUCTWORK, EQUIPMENT, CONDUIT, FIRE PROTECTION, AND LIGHTING.																			
25.	OVERCURRENT PROTECTION FOR HVAC EQUIPMENT SHALL BE PER THE MANUFACTURER'S NAMEPLATE, FUSE, OR HACR TYPE BREAKER.																			
26.	LABEL ALL RECEPTACLE FACE PLATES WITH PANEL AND CIRCUIT NUMBER.																			

ABBREVIATIONS	
(E)	EXISTING
(R)	RELOCATED
(RE)	REPLACED
A	AMPERES
AC	ABOVE COUNTER
AF	AMPERE FRAME
AFF	ABOVE FINISHED FLOOR
AFG	ABOVE FINISHED GRADE
AHJ	AUTHORITY HAVING JURISDICTION
AT	AMP TRIP
AWG	AMERICAN WIRE GAUGE
BMS	BUILDING MANAGEMENT SYSTEM
BW	BLANKET WARMER
C	CONDUIT
CB	CIRCUIT BREAKER
CC	CRASH CART
CKT	CIRCUIT
CL	CRITICAL LOAD
CM	CEILING MOUNTED
CO	CONDUIT ONLY, PROVIDE PULL-LINE
D	MECHANICAL DUCT-MOUNTED DEVICE
DC	DIRECT CURRENT
DET	DETAIL
E	EMERGENCY CRITICAL CARE
EF	EXHAUST FAN
EL	EMERGENCY LIGHT
EWC	ELECTRIC WATER COOLER
EWV	ELECTRIC WATER HEATER
F	FUSE
FACP	FIRE ALARM CONTROL PANEL
FVNR	FULL VOLTAGE NON-REVERSING
G/GND	GROUND
GFI	GROUND FAULT INTERRUPTION
GFP	GROUND FAULT PROTECTION
H	HEAT
HH	HANDHOLE
HID	HIGH INTENSITY DISCHARGE
HOA	HAND OFF AUTO
HP	HOUSE PHONE
HVAC	HEATING, VENTILATING, & AIR CONDITIONING
I	IONIZATION
IC	INTERRUPTING CAPACITY
ID	IN-DUCT
IG	ISOLATED GROUND
J/JB	JUNCTION BOX
KW	KILOWATT
KWH	KILOWATT HOUR
M	MAGNETIC CONTACTOR COIL
MB	MAIN BREAKER
MCC	MOTOR CONTROL CENTER
MH	MANHOLE
MLO	MAIN LUGS ONLY
MS	MOTOR STARTER
MW	MICROWAVE
N	NEUTRAL
NC	NORMALLY CLOSED
NCL	NON CRITICAL LOAD
NEC	NATIONAL ELECTRICAL CODE
NIC	NOT IN CONTRACT
NO	NORMALLY OPEN
NTS	NOT TO SCALE
OFCI	OWNER FURNISHED CONTRACTOR INSTALLED
OL	OVERLOAD
OS	OCCUPANCY SENSOR
P	PHOTO
PC	PHOTOCELL
PVC	POLYVINYL CHLORIDE
RCPT	RECEPTACLE
REF	REFRIGERATOR
SPST	SINGLE POLE SINGLE THROW
TC	TIME CLOCK
TDR	TIME DELAY RELAY
TJB	TERMINAL JUNCTION BOX
TSP	TWISTED SHIELDED PAIR
TTB	TELEPHONE TERMINAL BOARD
TVSS	TRANSIENT VOLTAGE SURGE SUPPRESSER
TYP	TYPICAL
UH	UNIT HEATER
UNO	UNLESS NOTED OTHERWISE
V	VOLT
VA	VOLT AMPERE
WG	PROVIDE PROTECTIVE WIRE GUARD
WP	WEATHER PROOF/NEMA 3R
XFMR	TRANSFORMER

POWER	
	DUPLEX NEMA 5-20A OUTLET. +18" AFF UNO.
	DUPLEX NEMA 5-20A OUTLET. MOUNT ABOVE COUNTER UNO.
	DUPLEX 20A OUTLET. +18" AFF UNO WITH GROUND FAULT INTERRUPTION PROTECTION.
	DUPLEX 20A OUTLET. MOUNTED ABOVE COUNTER UNO WITH GROUND FAULT INTERRUPTION PROTECTION.
	DUPLEX NEMA 5-20A RECEPTACLE WITH INTEGRAL USB CHARGING. +18" AFF UNO.
	FOURPLEX 20A OUTLET. +18" AFF UNO.
	FOURPLEX 20A OUTLET. MOUNTED ABOVE COUNTER UNO.
	SPECIAL PURPOSE OUTLET, VERIFY SIZE AND TYPE WITH EQUIPMENT SUPPLIER.
	CONNECTION POINT TO EQUIPMENT SPECIFIED, FURNISHED, AND INSTALLED UNDER OTHER SECTIONS. ELECTRICAL CONTRACTOR TO SUPPLY RACEWAY AND CONDUCTORS AND MAKE FINAL CONNECTION TO EQUIPMENT UNDER THIS SECTION, UNO.
	MOTOR CONNECTION. RE: MECHANICAL EQUIPMENT SCHEDULE.
	MOTOR STARTER/CONTACTOR.
	COMBINATION STARTER AND DISCONNECT.
	NON-FUSED DISCONNECT SWITCH. SIZE AS INDICATED, NEMA 1 UNO, 3 POLE UNO.
	FUSED DISCONNECT SWITCH. SIZE AS INDICATED, NEMA 1 UNO, 3 POLE UNO.

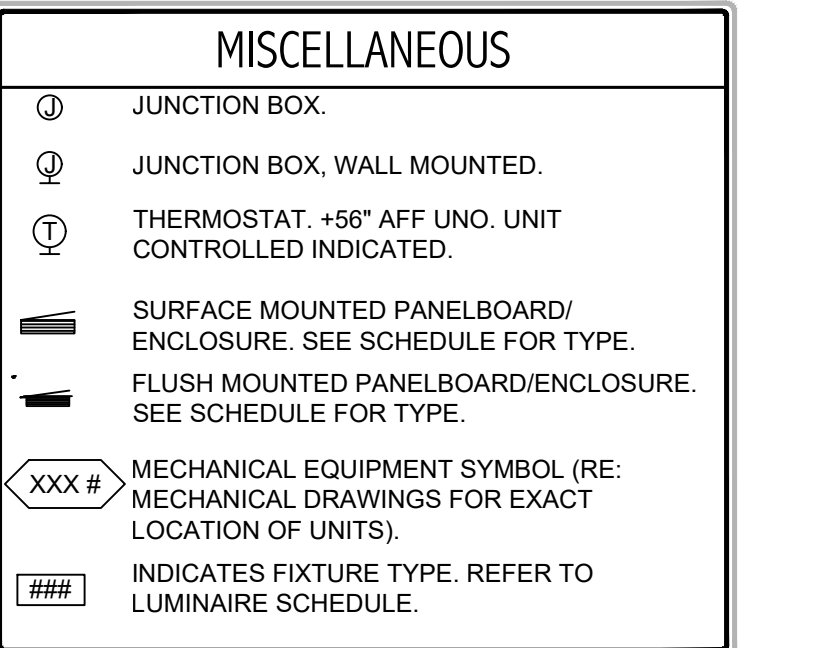
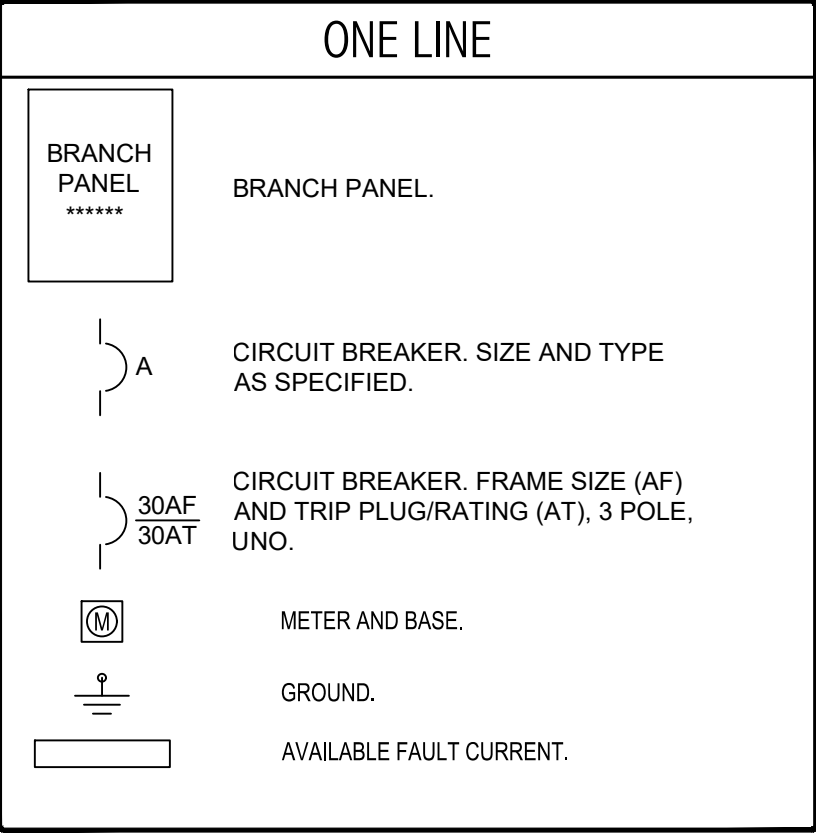
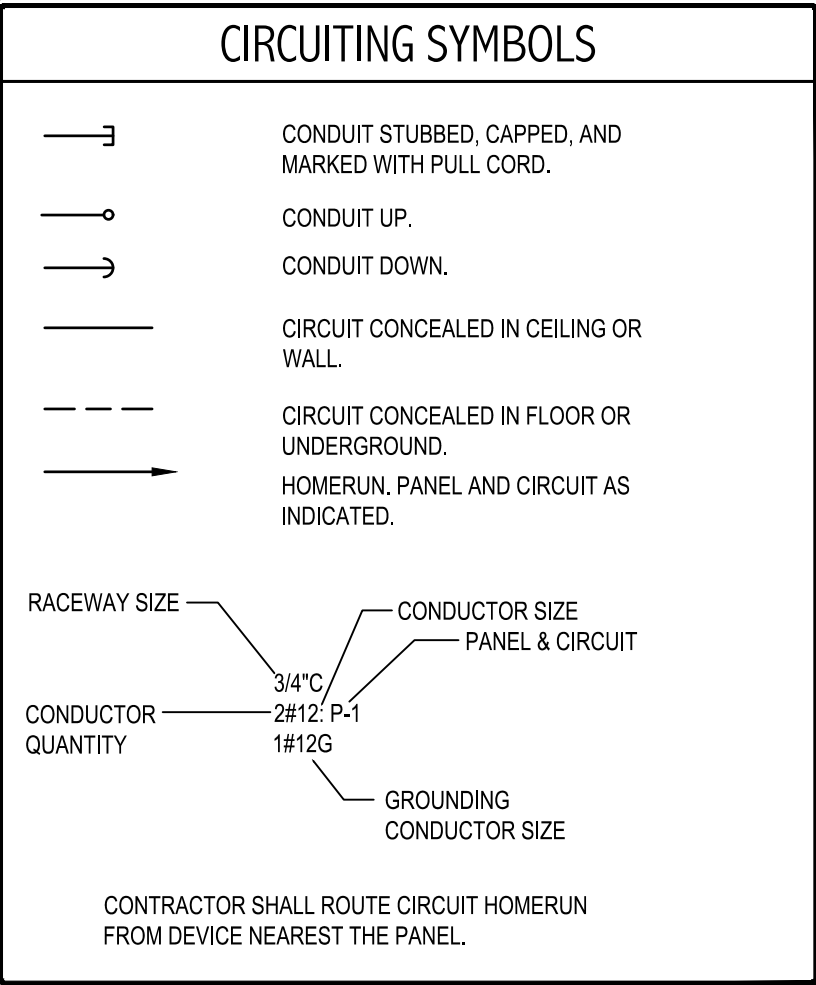

LIGHTING (SEE LUMINAIRE SCHEDULE FOR EXACT REQUIREMENTS)	
	SINGLE FACE EXIT SIGN, CEILING MOUNTED.
	DOUBLE FACE EXIT SIGN, CEILING MOUNTED.
	SINGLE FACE EXIT SIGN, WALL MOUNTED.
	DOUBLE FACE EXIT SIGN, WALL MOUNTED.
	SINGLE FACE COMBO EXIT SIGN/ EMERGENCY LUMINAIRE, WALL MOUNTED.
	2x2' RECESSED LED LIGHT FIXTURE.
	2x4' RECESSED LED LIGHT FIXTURE.
	PENDANT LIGHT FIXTURE.
	EMERGENCY PENDANT LIGHT FIXTURE.
	RECESSED LIGHT FIXTURE.
	EMERGENCY EGRESS LIGHT, WALL MOUNTED.
	EMERGENCY EGRESS LIGHT, CEILING MOUNTED.

SWITCHES	
	SWITCH. TYPE AS INDICATED. +46" AFF, UNO.
2	DOUBLE POLE
3	3-WAY
4	4-WAY
D	DIMMER. LUTRON DVSTV
F	CEILING FAN CONTROLLER
HP	HORSE POWER RATED
K	KEYED
LV	LOW VOLTAGE
M	MOMENTARY CONTACT
MM	MANUAL MOTOR STARTER
OS	OCCUPANCY SENSOR
P	PILOT LIGHT
T	15 MINUTE TIMER
TO	THERMAL OVERLOAD
V	VOLUME CONTROL
VS	VACANCY SENSOR
a	SUPERSCRIPIT INDICATES LIGHTS TO BE SWITCHED TOGETHER
SS	MULTI-LEVEL SWITCHING. TO MEET LIGHT REDUCTION LEVELS PER ENERGY CODE AS SHOWN, PROVIDE ADDITIONAL OR STEP-DIMMING BALLASTS WHERE REQUIRED.
	INFRARED OCCUPANCY SENSOR SWITCH - CEILING MOUNTED.

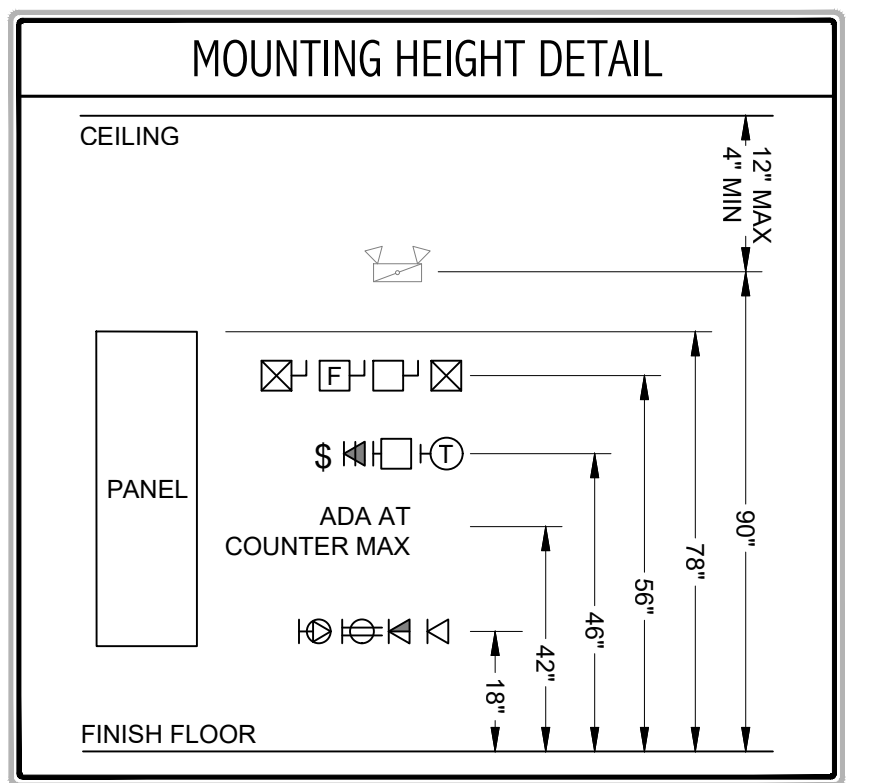

GENERAL SYMBOLS	
	NEW
	EXISTING
	DEMO
	EXISTING ITEM TO BE REMOVED AND RELOCATED (R)

09/20/23		DATE
		APP.
		INT.
		NO.

ACTION	BY	DATE
DESIGNED	BJ	08-18-23
DRAWN	BC	08-18-23
CHECKED (FIELD)	XX	XX/XX/XX
CHECKED (HDQTS.)	XX	XX/XX/XX

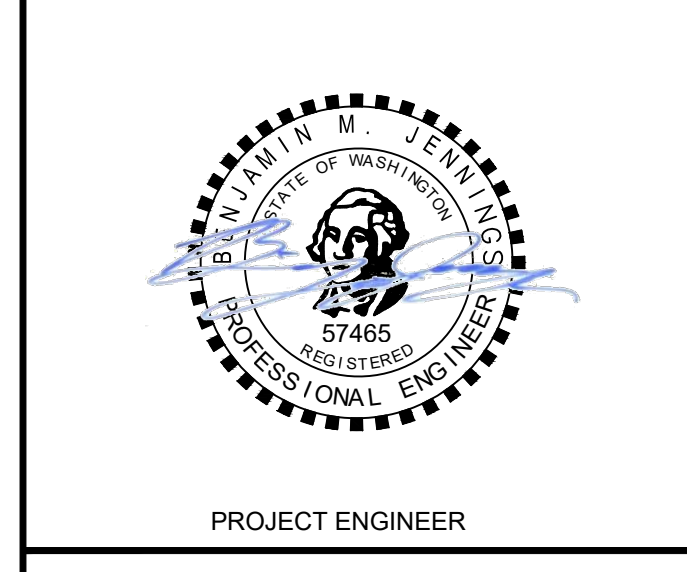

WASHINGTON STATE PARKS AND RECREATION COMMISSION

LEWIS & CLARK TRAIL STATE PARK

COMFORT STATION RENOVATION

ELECTRICAL LEGENDS & ABBREVIATIONS

09/20/23

DATE

APP.

INT.

REVISIONS

NO.

ACTION	BY	DATE
DESIGNED	BJ	08-18-23
DRAWN	BC	08-18-23
CHECKED (FIELD)	XX	XX/XX/XX
CHECKED (HDQTS.)	XX	XX/XX/XX

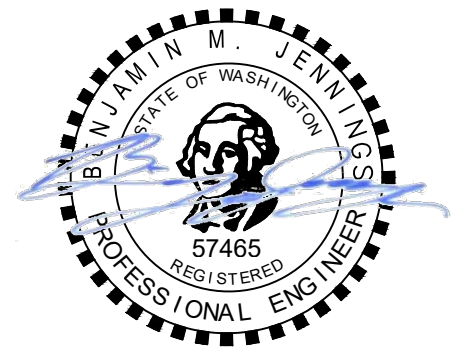

PROJECT ENGINEER

WASHINGTON STATE PARKS AND RECREATION COMMISSION



LEWIS & CLARK TRAIL STATE PARK

COMFORT STATION RENOVATION

ELECTRICAL SCHEDULES AND SINGLE LINE

SHEET 15 OF 17

SCALE

PARKS FILE#

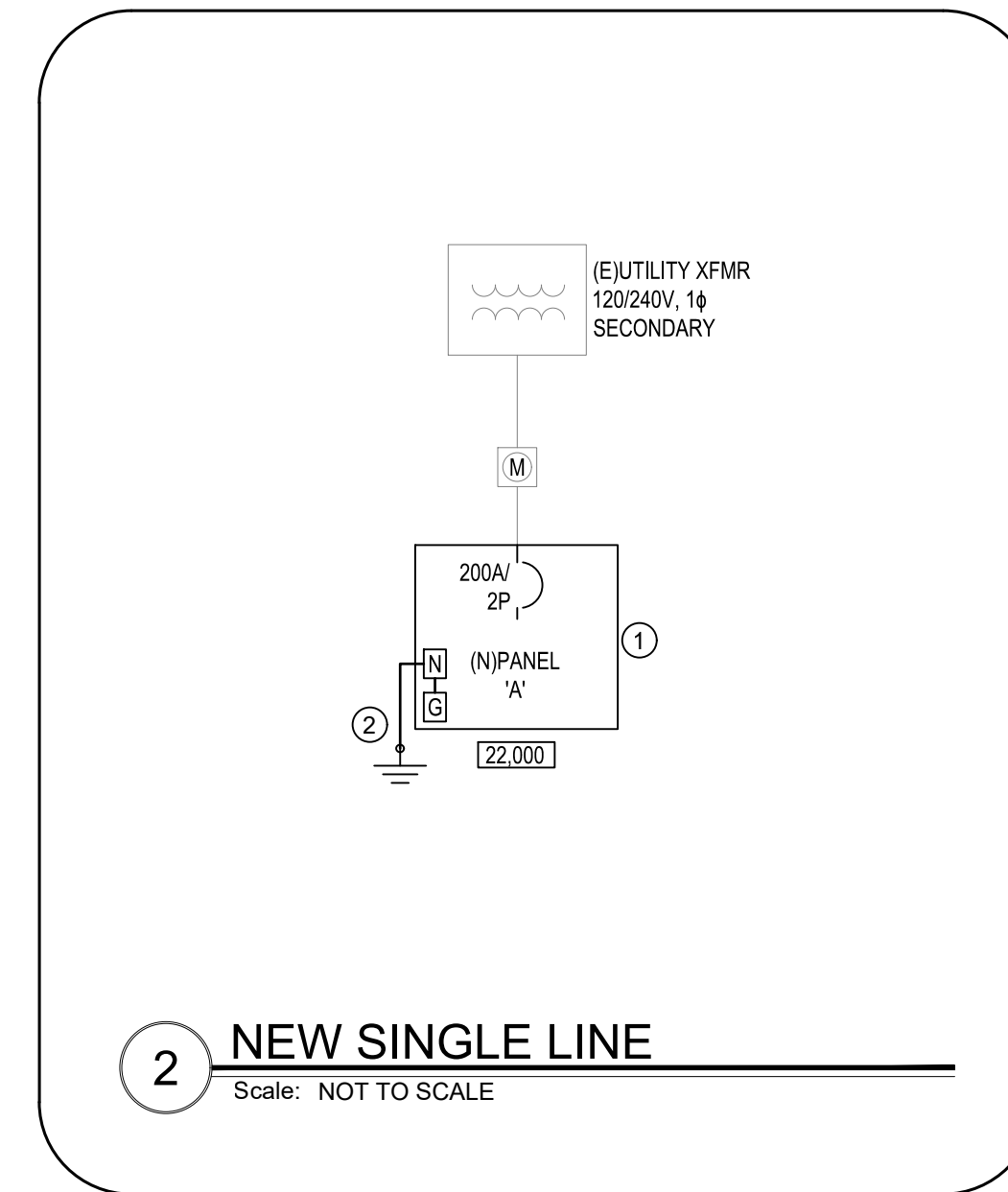
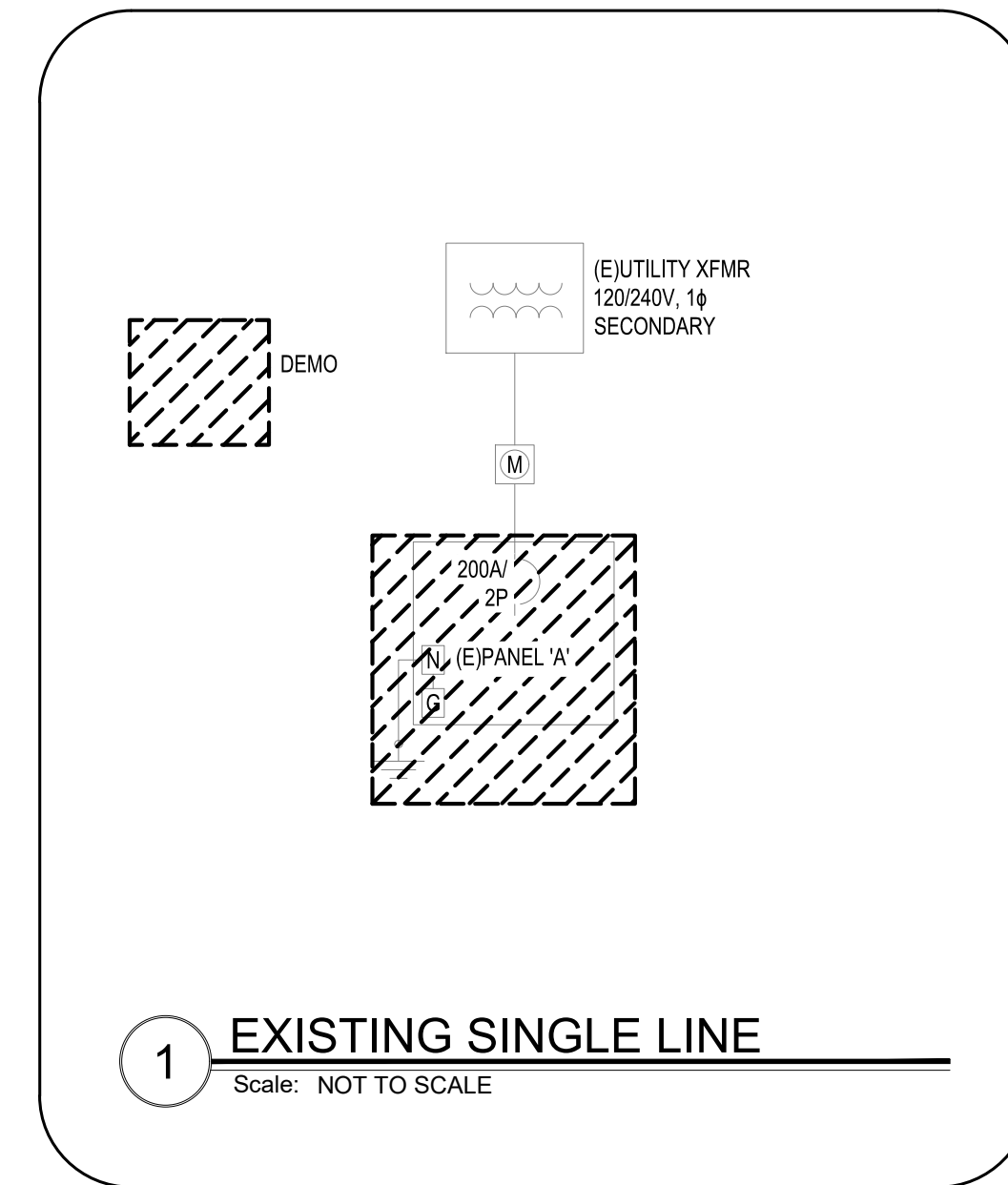

- KEY NOTES**
- PANELBOARD TO BE REPLACED IN PLACE WITH NEW LOCKABLE PANELBOARD PER PANEL SCHEDULE ON THIS SHEET. CONNECT TO EXISTING-TO-REMAIN SERVICE CONDUCTORS AND BRANCH CIRCUITS.
  - EXISTING BUILDING GROUND TO BE REMOVED/RELOCATED OUT OF WALKING PATH. INTERCEPT AND EXTEND OUT OF WALKWAY. PROVIDE/ESTABLISH NEW BUILDING GROUND IF REQUIRED.

MSI ENGINEERS																
PANEL: A (NEW)																
VOLTAGE: 240/120V PHASE: 1 WIRE: 3 MINIMUM AIC RATING: SEE SINGLE LINE 200A MAIN BREAKER SERVICE ENTRANCE RATED																
AMPERE RATING: 200A ENCLASURE RATING: NEMA 1																
CKT NO	LOAD (VA)	LOAD SERVED	NOTE	LOAD TYPE	AMPS/ POLES	PHASE A	PHASE B	AMPS/ POLES	LOAD TYPE	NOTE	LOAD SERVED	LOAD (VA)	CKT NO			
1	1375	WALL HEATERS EWH-1,2,3		N	MC	20	2	3775	40	2	MC	E	KITCHEN SHELTER	2400	2	
3	1375	WALL HEATERS EWH-1,2,3		N	MC	*	*	3775	*	*	MC	E	KITCHEN SHELTER	2400	4	
5	180	REC-RESTROOM		E	R	15	1	680	20	1	MC	E	WEST SHELTER	500	6	
7	500	LIGHTS		E	L	15	1	1500	30	2	MC	E	INTERP. SHELTER	1000	8	
9	180	REC-RESTROOM		E	R	20	1	1180	*	*	MC	E	INTERP. SHELTER	1000	10	
11	750	MERCURY LIGHTS		E	L	15	1	988	20	1	MC	E	RESTROOM LIGHTS	238	12	
13	500	EXISTING		E	MC	15	1	1000	20	1	MC	E	AREA LIGHTS	500	14	
15		SPARE		S		20	1		750	20	2	MC	N	WATER HEATER WH-1	750	16
17	500	EXISTING		E	MC	20	1	1250	*	*	MC	N	WATER HEATER WH-1	750	18	
19	1920	SEWAGE PUMP PANEL(1HP)		E	MT	30	2	6720	50	2	MC	N	EV CHARGER	4800	20	
21	1920	SEWAGE PUMP PANEL(1HP)		E	MT	*	*	6720	*	*	MC	N	EV CHARGER	4800	22	
23	1250	WALL HEATERS EWH-5,6		N	MC	20	2	6050	50	2	MC	N	EV CHARGER	4800	24	
25	1250	WALL HEATERS EWH-5,6		N	MC	*	*	6050	*	*	MC	N	EV CHARGER	4800	26	
27	625	WALL HEATER EWH-4		N	MC	20	2	973	20	1	MT	N	UTILITY RM EXHAUST FAN EF-1	348	28	
29	625	WALL HEATER EWH-4		N	MC	*	*	1575	20	1	MC	N,G	HAND DRYER	950	30	
31		SPARE				20	1		0	20	1		SPARE		32	
33		SPARE				20	1		0	20	1		SPARE		34	
35		SPARE				20	1		0	20	1		SPARE		36	
37		SPARE				20	1		0	20	1		SPARE		38	
39		SPARE											SPARE		40	
41		SPARE											SPARE		42	

CONNECTED LOADS:		Amps	VA	LOAD TYPES:	
PHASE A:	185	22230		L = LIGHTING	
PHASE B:	173	20756		R = RECEPTACLES	
TOTAL:		42986		MC = MISC	
				MT = MOTOR	
				K = KITCHEN	
				LARGEST MOTOR =	1824.0
				# OF KITCHEN =	

LOADING BY TYPE	DEMAND FACTOR	DEMAND	NEC CODE
L	125%	1563 VA	210-19
R	10kVA @ 100% REM @ 50%	360 VA	220-44
MC	100%	37188 VA	220-60
MT	100% + LARGEST x 25%	4644 VA	220-50
K		0 VA	220-56
TOTAL		43755	182

NOTES:	
E	- EXISTING-TO-REMAIN CIRCUIT; RE-CONNECT AS SHOWN.
N	- NEW CIRCUIT/LOAD.
S	- CIRCUIT SPARED OUT
G	- PROVIDE GFCI BREAKER



09/20/23

DATE

APP.

INT.

REVISIONS

NO.

ACTION	BY	DATE
DESIGNED	BJ	08-18-23
DRAWN	BC	08-18-23
CHECKED (FIELD)	XX	XX/XX/XX
CHECKED (HDQTS.)	XX	XX/XX/XX

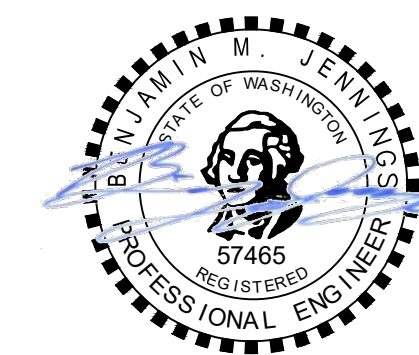

PROJECT ENGINEER

WASHINGTON  
STATE  
PARKS  
AND  
RECREATION  
COMMISSION



LEWIS & CLARK  
TRAIL STATE PARK

COMFORT STATION  
RENOVATION

ELECTRICAL  
SITE PLAN

SHEET 16 OF 17

SCALE



PARKS FILE#

GENERAL NOTES

- COORDINATE UNDERGROUND CONDUIT ROUTING WITH FIELD CONDITIONS AND WORK OF OTHER TRADES.

KEY NOTES

- PROVIDE 1" C STUBBED INTO NEW UTILITY ROOM FOR ETHERNET CONNECTION.
- COORDINATE EXACT LOCATION WITH ARCHITECT.

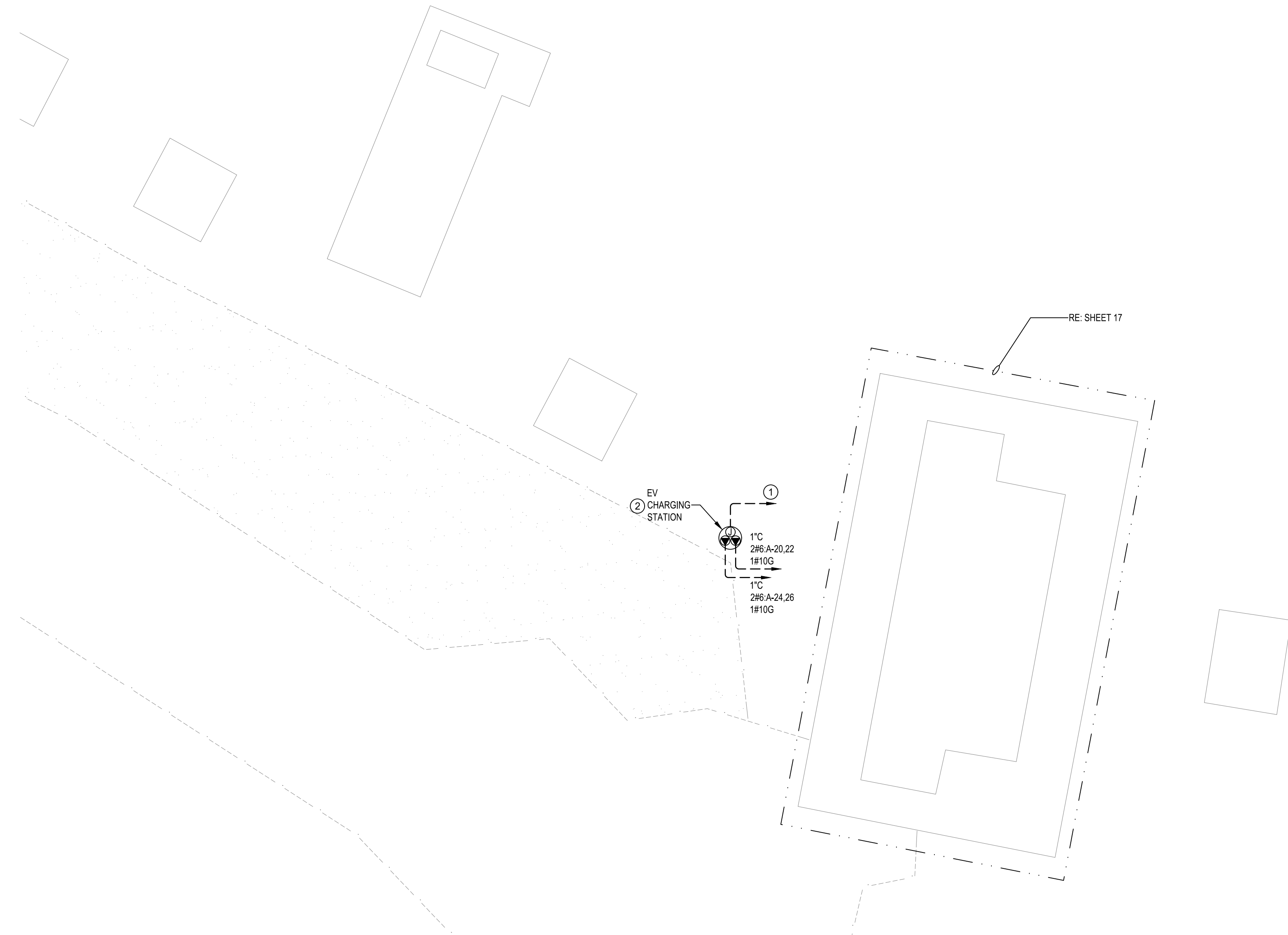

SITE PLAN - ELECTRICAL

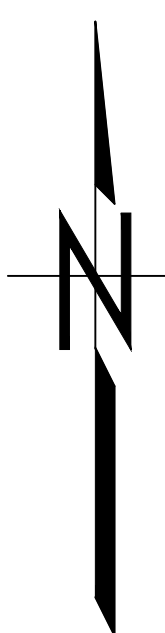

09/20/23

DATE

APP.

INT.

REVISIONS

NO.

ACTION	BY	DATE
DESIGNED	BJ	08-18-23
DRAWN	BC	08-18-23
CHECKED (FIELD)	XX	XX/XX/XX
CHECKED (HDQTS.)	XX	XX/XX/XX

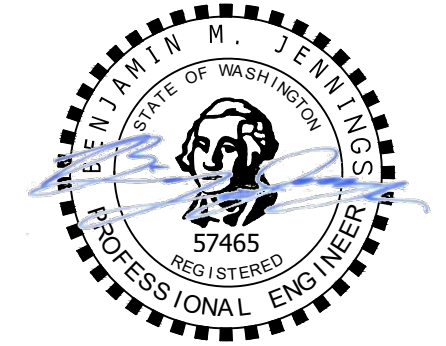

PROJECT ENGINEER

WASHINGTON STATE PARKS AND RECREATION COMMISSION



LEWIS & CLARK TRAIL STATE PARK

COMFORT STATION RENOVATION

ELECTRICAL DEMO PLAN AND FLOOR PLAN

SHEET 17 OF 17

SCALE

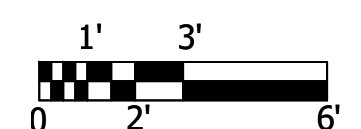

PARKS FILE#

GENERAL NOTES

- CONTRACTOR RESPONSIBLE FOR DISPOSAL OF ALL DISCONNECTED MATERIALS.

KEY NOTES

- EQUIPMENT TO BE DISCONNECTED AND REMOVED BY MECHANICAL CONTRACTOR; DISCONNECT AND REMOVE ALL ASSOCIATED CONDUIT, CONDUCTORS, CABLING, AND ELECTRICAL DISCONNECT DEVICES.
- PANEL TO BE REPLACED IN PLACE. RETAIN AND PROTECT PANEL FEEDER AND ALL CIRCUITS UNAFFECTED BY DEMOLITION.
- DISCONNECT AND REMOVE 220V PLUG NEXT TO PANEL. DISCONNECT AND REMOVE ALL ASSOCIATED CONDUIT AND CONDUCTORS.
- EXISTING GROUND ROD TO BE DISCONNECTED AND REMOVED.
- DISCONNECT AND REMOVE EXISTING FIXTURE/DEVICE. RETAIN AND PROTECT CONDUIT AND CONDUCTORS.

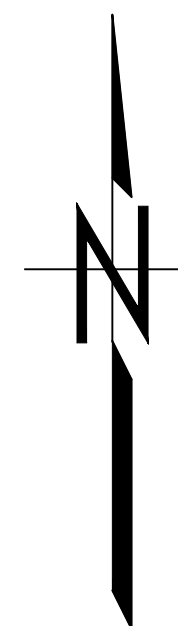
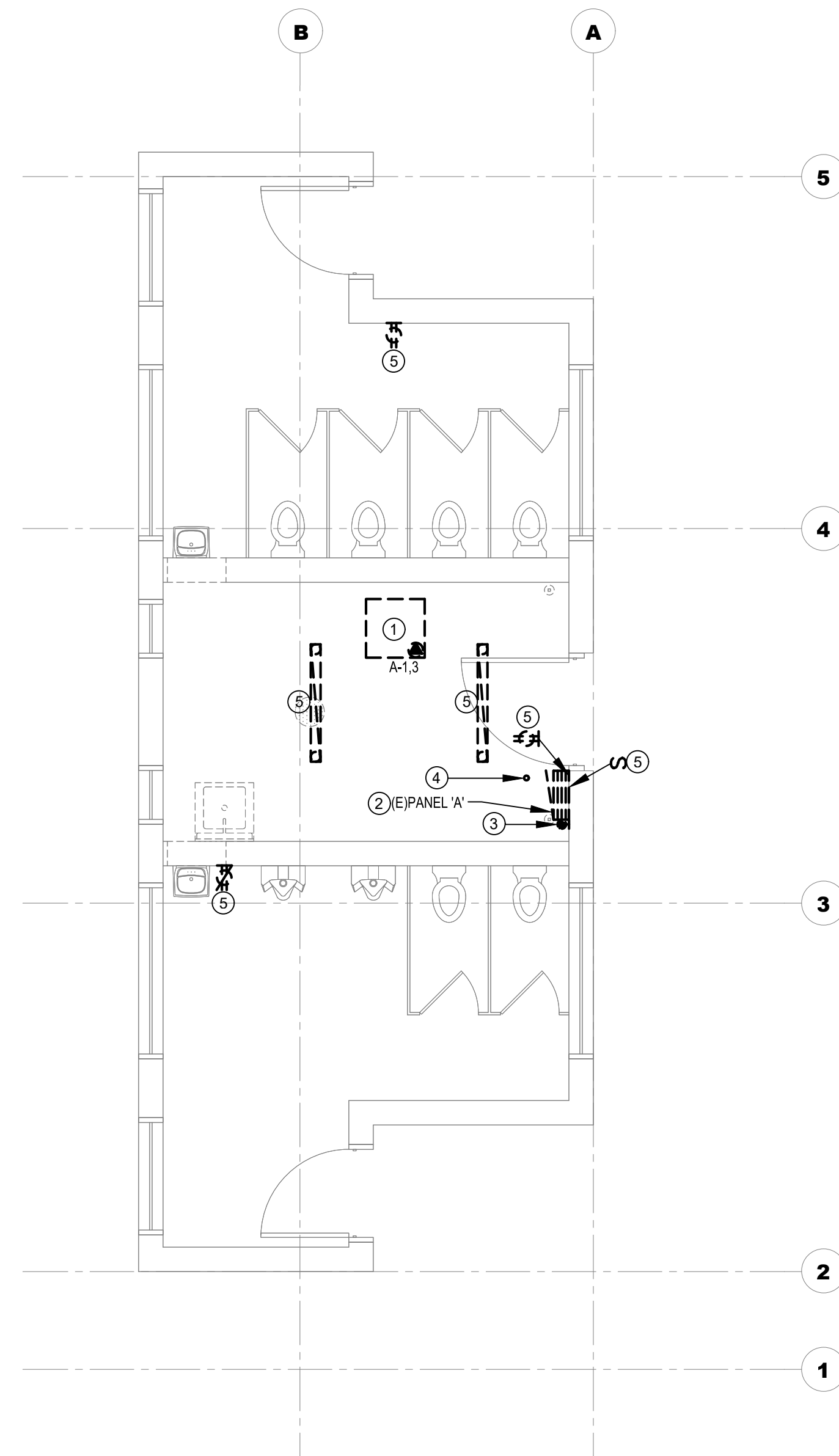

DEMO PLAN - ELECTRICAL

GENERAL NOTES

- WALL HEATERS ARE PROVIDED WITH FACTORY DISCONNECTS PER MECHANICAL DRAWINGS.

KEY NOTES

- PANEL REPLACED IN PLACE; SEE PAGE 15 OF 17 FOR NEW PANEL REQUIREMENTS.
- LIGHTING TIME SWITCH AND ON/TIMER SWITCH TO BE RELOCATED TO LOCATION INDICATED. EXTEND CONDUIT/CONDUCTORS AND RECONNECT TO DOWNSTREAM LIGHT FIXTURES AS WELL PANEL BRANCH CIRCUIT BREAKER.
- PROVIDE NEW UFER GROUND IN NEW CONCRETE SLAB. RE-CONNECT TO NEW PANELBOARD AND NEARBY STRUCTURES PER PREVIOUS GROUNDING CONFIGURATION.
- REPLACE RECEPTACLE WITH GFCI RECEPTACLE. RE-CONNECT TO EXISTING CONDUIT/CONDUCTORS.
- REPLACE LIGHT FIXTURE IN PLACE; CONNECT TO EXISTING-TO-REMAIN CONDUIT/CONDUCTORS.
- INTERCEPT AND EXTEND CIRCUIT TO NEW FIXTURE SHOWN.
- PROVIDE NEW LUMINAIRE: LITHONIA CSV-T-L48-4000LM-4VOLT-40K-80CRI OR EQUIVALENT.
- REPLACE SWITCH IN PLACE WITH NEW OCCUPANCY SENSOR SWITCH.
- COORDINATE SWITCH MOUNTING HEIGHT/LOCATION WITH THAT OF NEW WALL HEATER.
- RELOCATED FAN TIMER/SWITCH PER MECHANICAL DRAWINGS. CONNECT TO 'EF-1' VIA 3/4" C, 2#12 AWG CU, #12 CU GROUND.
- COORDINATE EXACT HAND DRYER LOCATION WITH ARCHITECTURAL DRAWINGS.

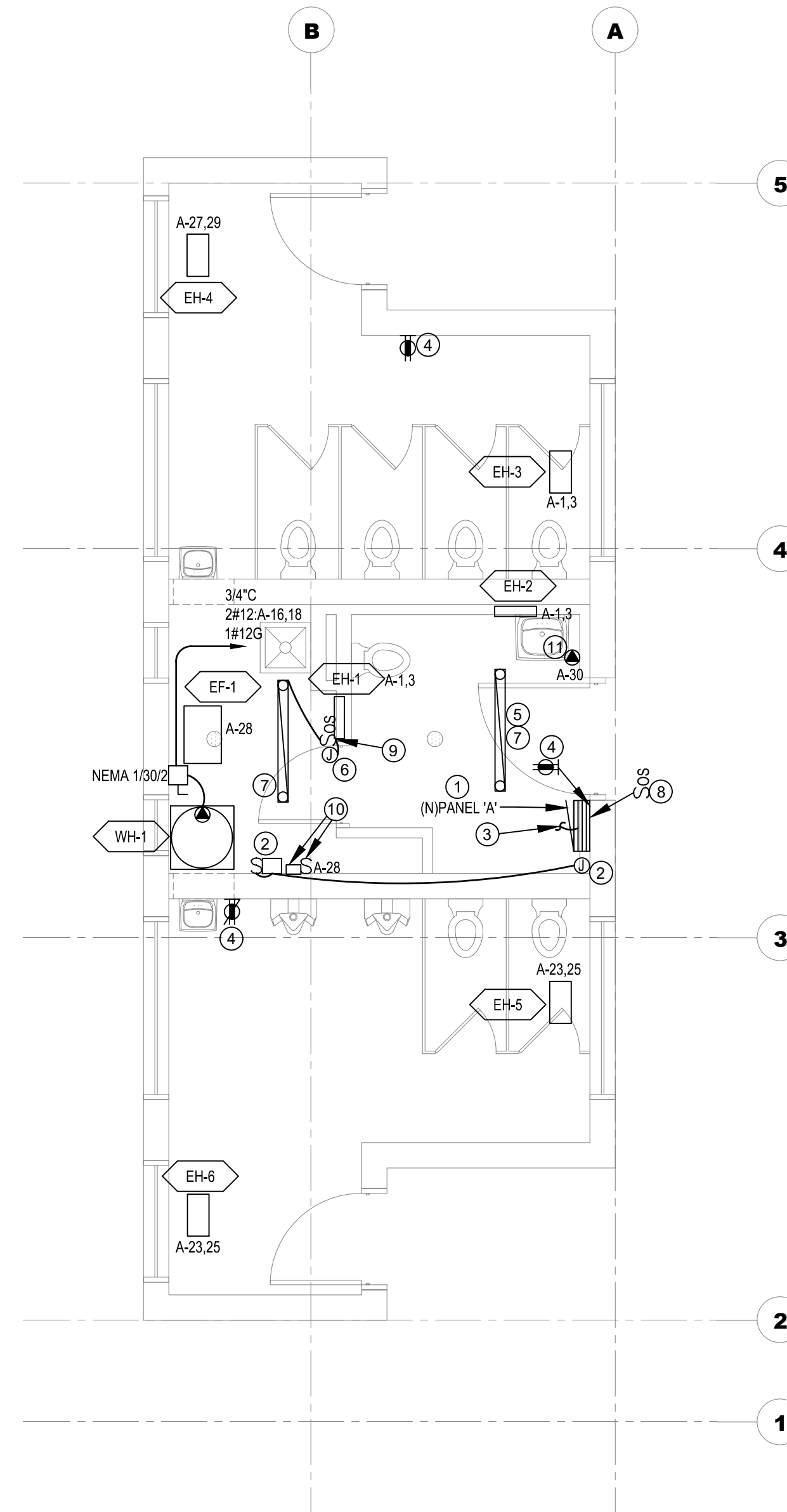

FLOOR PLAN - ELECTRICAL

# PRE-BID MEETING

<b>STATE PARK</b>	Lewis and Clark Trail State Park	<b>DATE:</b>	12/4/2024
<b>PROJECT NAME</b>	Comfort Station Renovation	<b>TIME:</b>	2:00pm
<b>ATTENDEES</b>			
<b>NAME</b>	<b>TITLE</b>	<b>FIRM NAME AND ADDRESS</b>	<b>PHONE, FAX, E-MAIL</b>
Gabe Yost	Field Engineer	Wesslen Construction	(509)998-9934
		Spokane Valley	
Aaron Mangum	PM	Mangum Construction	(509)254-1034
		1451 Bridge Street	
		Clarkston, WA	<a href="mailto:aaron@mangum-construction.com">aaron@mangum-construction.com</a>
Joe Hunt	PM	JK Greystone	(208)997-1645
		1026 Hall Rd	
		Viola, ID 83872	
Aaron Grimm	GC	ESF Development (DBA ESF Solutions)	(509)730-1537
			<a href="mailto:aaron@esfsolutionsllc.com">aaron@esfsolutionsllc.com</a>
Trent Depping	Estimator	WW Electric	(509)525-8672
		1225 W Poplar	
		Walla Walla, WA	<a href="mailto:trent@wwelectric.com">trent@wwelectric.com</a>
Matt Triebwasser	PM	Nelson Construction	(509)301-6045
			<a href="mailto:matt@nelson-corp.com">matt@nelson-corp.com</a>
Jordan Mattila	CEO	47 North Custom Homes	(509)845-9242
		1360 N. Louisiana St #A-733	<a href="mailto:47northhomes@gmail.com">47northhomes@gmail.com</a>
		Kennewick, WA 99336	

